

1529 / 1532 Tractor Operator Instruction Book

**MASSEY FERGUSON®
1529 / 1532 Tractor
1857695M1
CONTENTS**

SAFETY	1
Safety Alert Symbol	1
Safety Messages	1
Informational Messages	1
Safety Signs	2
A Word To The Operator	2
Operator Manual	3
Prepare For Operation	3
Roll-Over Protective Structure (ROPS)	3
Operation	4
Travel on Public Roads	9
Maintenance	10
Safety Signs	14
GENERAL INFORMATION	21
Introduction	21
Machine Identification	22
Major Components	24
OPERATION	25
Instruments and Controls	25
1. Instrument Panel	26
Clutch Pedal	30
Brakes	30
Break-In Period	31
Starting the Tractor	31
Engine Speed Controls	34
Standard Transmission	35
Synchroshuttle Transmissions	37
Stopping the Tractor	40
Parking the Tractor	40
Differential Lock	41
Four-Wheel Drive	41
Power Take-Off (PTO)	42
Three-Point Hitch	45
Drawbar	49
Joystick (Option)	50
External Auxiliary Hydraulics (Option)	53
Roll-Over Protective Structure (ROPS)	54
LUBRICATION AND MAINTENANCE	57
Inspection and Maintenance Chart	57
Torque Chart	58
Specifications and Capacities	58
Lubrication/Fill Points	59
Service Access	60
Lubrication Details	62
Cooling System	66
Engine Air Cleaner	68
Fuel System	70
Electrical System	73
Wiring Diagrams	77
Clutch Free-Play Adjustment	81
Brake Adjustment	82
Wheels and Tires	83
Clutch Housing Plug	86

CONTENTS

Storage	87
TROUBLESHOOTING	89
SPECIFICATIONS	97
Engine	97
Transmission	98
Power Take-Off (PTO)	98
Hydraulic System	99
Electrical System	99
Capacities	99
Maximum Load Capacity	100
General Dimensions	101
ACCESSORIES AND OPTIONS	103
Canopy	103
Engine Block Heater	103
Rear Work Light(s)	103
Front Weight Frame	103
Rear Weight Frame	103
Hang-On Weights	103
Single or Two Spool Auxiliary Valve	103
Mid PTO (Type S Only)	103
Implements and Attachments	103
ASSEMBLY	105
Assembling the tractor	105
Clutch Free-Play Adjustment	109
Pre-Delivery Inspection Checklist	111
Delivery Checklist	114
INDEX	117

SAFETY

SAFETY ALERT SYMBOL

FIG. 1: The safety alert symbol means ATTENTION! BECOME ALERT! YOUR SAFETY IS INVOLVED!

Look for the safety alert symbol both in this manual and on safety signs on this machine. The safety alert symbol will direct your attention to information that involves your safety and the safety of others.



FIG. 1

SAFETY MESSAGES

FIG. 2: The words DANGER, WARNING or CAUTION are used with the safety alert symbol. Learn to recognize these safety alerts and follow the recommended precautions and safety practices.

 **DANGER:** Indicates an imminently hazardous situation that, if not avoided, will result in DEATH OR VERY SERIOUS INJURY.

 **WARNING:** Indicates a potentially hazardous situation that, if not avoided, could result in DEATH OR SERIOUS INJURY.

 **CAUTION:** Indicates a potentially hazardous situation that, if not avoided, may result in MINOR INJURY.



FIG. 2

INFORMATIONAL MESSAGES

The words IMPORTANT and NOTE are not related to personal safety, but are used to give additional information and tips for operating or servicing this equipment.

IMPORTANT: Identifies special instructions or procedures which, if not strictly observed, could result in damage to or destruction of the machine, process, or its surroundings.

NOTE: Identifies points of particular interest for more efficient and convenient repair or operation.

SAFETY

SAFETY SIGNS



WARNING: DO NOT remove or obscure Danger, Warning or Caution signs. Replace any Danger, Warning or Caution signs that are not readable or are missing. Replacement signs are available from your dealer in the event of loss or damage. The actual location of the safety signs is illustrated at the end of this section.

If a used machine has been purchased, make sure all safety signs are in the correct location and can be read.

See Safety Sign Location of this section for illustrations.

Replace any safety signs that can not be read or are missing. Replacement safety signs are available from your dealer.

A WORD TO THE OPERATOR

FIG. 3: It is YOUR responsibility to read and understand the safety section in this book before operating this machine. Remember that YOU are the key to safety. Good safety practices not only protect you, but also the people around you. Study the features in this book and make them a working part of your safety program. Keep in mind that this safety section is written only for this type of machine. Practice all other usual and customary safe working precautions, and above all **REMEMBER - SAFETY IS YOUR RESPONSIBILITY. YOU CAN PREVENT SERIOUS INJURY OR DEATH.**

This safety section is intended to point out some of the basic safety situations that may be encountered during the normal operation and maintenance of your machine, and to suggest possible ways of dealing with these situations. This section is NOT a replacement for other safety practices featured in other sections of this book.

***IMPORTANT:** This manual covers general safety practices for this machine. It must always be kept with the machine. After using this manual, return it to the container on the machine.*



WARNING: An operator should not use alcohol or drugs which can affect their alertness or coordination. An operator on prescription or 'over the counter' drugs needs medical advice on whether or not they can properly operate machines.

Do not let anyone operate this machine without thorough instruction.

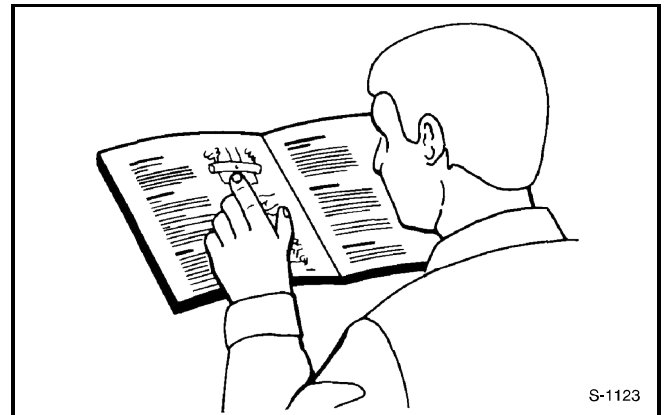

FIG. 3

OPERATOR MANUAL

The photos, illustrations, and data used in this manual were current at the time of printing, but due to possible in-line production changes, your machine can vary slightly in detail. The manufacturer reserves the right to redesign and change the machine as necessary without notification.



WARNING: In some of the illustrations or photos used in this manual, panels or guards may have been removed for clarity. Never operate the machine with any panels or guards removed. If the removal of panels or guards is necessary to make a repair, they MUST be replaced before operation.

This operator manual is compiled to cover safe working practices that are associated with the basic tractor operation.

The manual does not cover all operation and safety instructions relevant to all known implements and attachments that may be used at the time of tractor delivery or at some future date.

It is essential that operators use and understand the relevant instruction manuals of all implements and attachments.

PREPARE FOR OPERATION

Read this manual completely and make sure you understand the controls. Know the positions and operations of all controls before you operate this machine. Check all controls in an area clear of people and obstacles before starting your work.

All equipment has a limit. Make sure you understand the speed, brakes, steering, stability, and load characteristics of this machine and your tractor before you start.

Make sure your machine has the correct equipment needed by the local regulations.

ROLL-OVER PROTECTIVE STRUCTURE (ROPS)

Roll-over protective structure (ROPS) is effective in reducing injuries during overturns. Overturning a tractor without ROPS or with the ROPS folded down can result in serious injury or death. Operate with ROPS folded down only when conditions make this necessary. Return ROPS to upright, locked position as soon as conditions permit.

DO NOT weld, drill or alter the ROPS.

If the tractor has been rolled over or the ROPS frame has been damaged in any manner, the ROPS must be replaced. Do not attempt to repair a damaged ROPS. If damage does occur, consult your Dealer and replace all damaged parts.

Before using the tractor ensure that the ROPS frame is not damaged and that it is securely fastened to the tractor

DO NOT attach chains, ropes or cables to the ROPS for pulling purposes - damage to the ROPS and/or overturn of the tractor may result. Always pull from the tractor drawbar.

Observe all recommendations and instructions regarding the installation of covers or roofs which are used as SUNSHIELDS ONLY and do not afford the operator protection from falling objects.

SAFETY

OPERATION



DANGER: DO NOT attempt to unplug the hydraulic connections, or adjust an implement with the engine running or the PTO drive in operation. To do so may result in very serious injury or death.

Keep emergency telephone numbers for immediate access.

FIG. 4: Wear all protective clothing and personal protective equipment issued to you or called for by job conditions. Wear approved hearing protection whenever operating the machine as required by country/local regulations. **DO NOT** wear loose clothing, jewelry, or other items that could entangle in moving parts. Tie up long hair that also could entangle in moving parts. Always keep hands, feet, hair, and clothing away from moving parts.

Protective equipment that may be needed:

- A hard hat.
- Safety glasses, goggles, or face shield.
- Hearing protection.
- Respirator or filter mask.
- Inclement weather clothing.
- Reflective clothing.
- Heavy gloves (neoprene for chemicals, leather for rough work).
- Protective footwear.
- Other specialized protective gear.

Specific safety equipment may be required for the application of fertilizers, pesticides, etc. Follow all recommendations given by the chemical supplier and manufacturer.

DO NOT wear loose clothing, as this may catch on moving parts of the tractor or implement causing injury.

FIG. 5: Always wear the seat belt, correctly adjusted, during tractor operation unless operating with the ROPS folded down. Do not wear the seat belt when ROPS is folded down.

Check the seat belt for damage. A damaged seat belt must be replaced.

The seat belt for this tractor is located beside the seat. Sit in the seat, adjust the seat belt length, and fit the latch into the buckle.

Release the seat belt by pushing down on the buckle. Properly store the seat belt beside the seat.

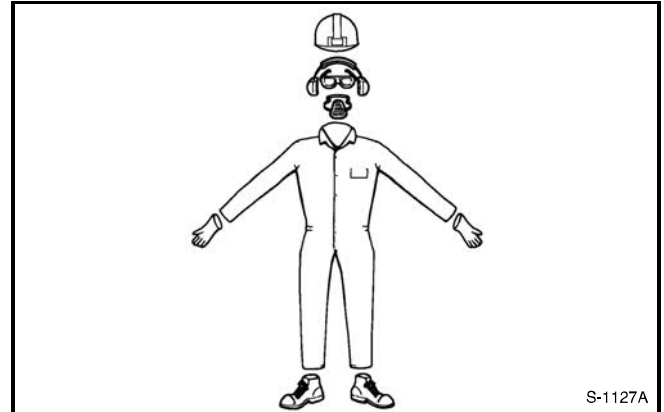

FIG. 4

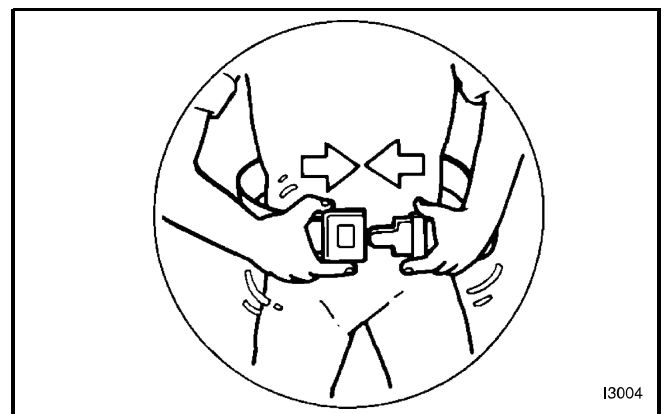

FIG. 5

FIG. 6: A fire extinguisher and first aid box should be carried with the tractor or be kept readily available at all times. Consult your Dealer.

Note where fire extinguishers and first-aid or emergency equipment are kept and get to know where to get help in a hurry. Make sure you know how to use this equipment.

Clear the area before operation.

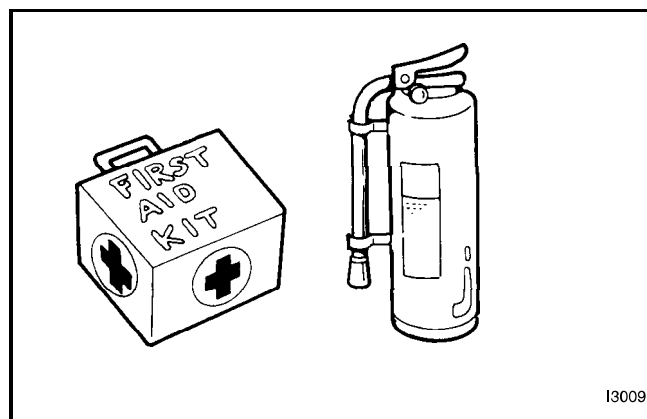

FIG. 6

FIG. 7: DO NOT carry passengers

DO NOT permit others to ride on the tractor or on any implement or attachment connected to, or installed on tractor.



FIG. 7

FIG. 8: Beware of bystanders, particularly children. Always look around to make sure that everyone is clear before starting the engine or moving the tractor. This is particularly important with higher noise levels as you may not hear people shouting.

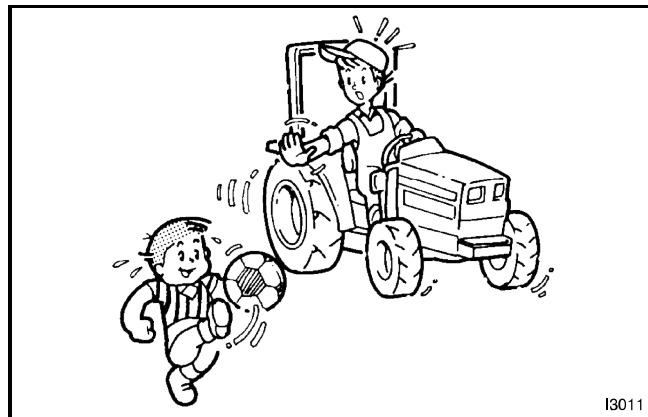

FIG. 8

FIG. 9: When dismounting and/or leaving the operator's seat FOR ANY REASON, always:

1. Disengage PTO drive.
2. Lower implements, attachments to ground.
3. Shut off engine.
4. Apply parking brake securely.
5. Select transmission lever(s) to neutral.
6. Remove the key.

Do not attempt to service machine, clear obstructions or unplug blockages with the engine running. Always shut off engine and allow all motion to cease.

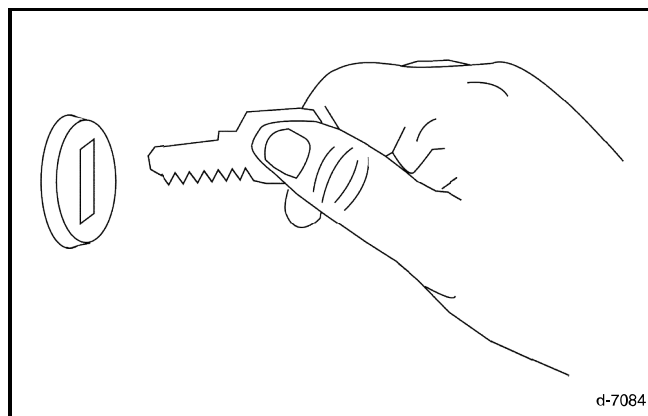

FIG. 9

SAFETY

FIG. 10: Always start the engine from the operator's seat with the transmission lever and the PTO lever in neutral.

DO NOT bypass the starting circuit by shorting across the terminals of the starter motor to start the engine. This may cause the tractor to move suddenly.

Periodically check starting circuit to make sure all system components operate correctly.

If the starting system does not work, consult your Dealer immediately.

Never attempt to start the engine while standing beside the tractor.

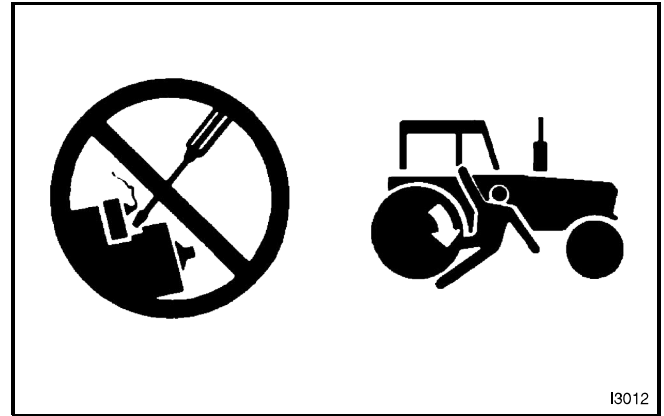

FIG. 10

FIG. 11: Keep clear of all rotating driveline components. Be especially observant of implement areas of discharge, intake or other mechanical motion.

Make sure rotating guards turn freely.

A loose yoke can slip off the tractor PTO shaft and result in injury to persons or damage to the machine.



FIG. 11

FIG. 12: Keep all shields in place.

Rear PTO (Power Take-Off) master shield (1) must be correctly installed at all times. PTO shaft cover(s) must be installed when PTO driveline is not in use.

Do NOT use PTO adapters. PTO shaft adapters, reducers and/or extensions extend the implement drive shaft coupler and universal joint beyond the protection of the PTO master shield.

Reduce PTO speed slowly. When stopping any PTO driven machine, idle the engine to reduce the PTO speeds before disengaging.

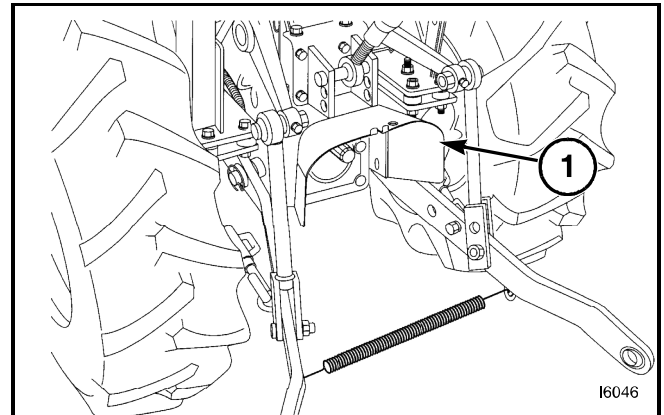

FIG. 12

FIG. 13: Implement drive shaft coupler (1) must securely lock to and be retained by annular groove on tractor PTO shaft.

Always disengage PTO, park the tractor, shut off engine and remove the key before:

- Connecting or disconnecting the implement drive shaft.
- Adjusting the PTO driveline or PTO-driven machine.
- Cleaning, unplugging or servicing PTO-driven machine.

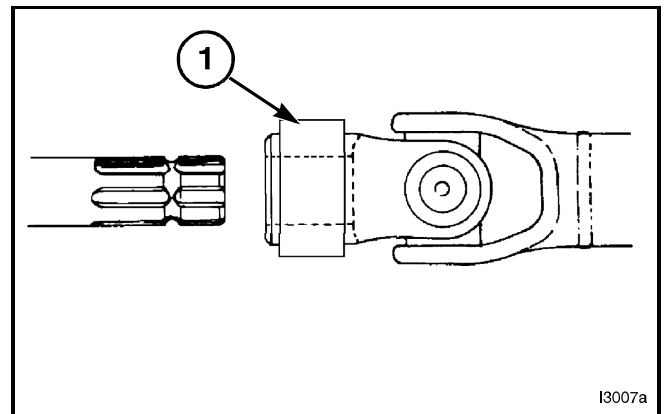

FIG. 13

FIG. 14: Starting fluid must only be used when an ether-start aid is fitted as original equipment by the manufacturer or when installed by a dealer as an approved accessory.

When tractors are equipped with glow plugs or other heating device, these **MUST** be removed prior to the usage of starting fluid or ether-starting aid.

Use of starting fluid on engine equipped with glow plugs can result in severe engine damage.



I3013a

FIG. 14

FIG. 15: If in an enclosed area, vent the exhaust to the outside. Always start and operate engine in a well-ventilated area.

Do not tamper with or modify the exhaust system with unapproved extensions

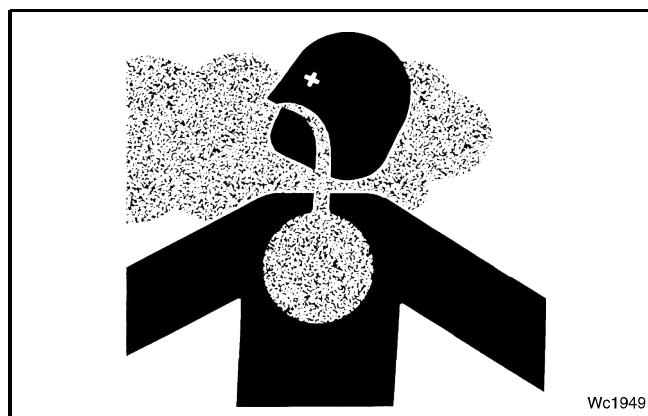

Wc1949

FIG. 15

FIG. 16: On models with independent brake pedals, keep the brake pedals latched together at all times unless independent braking is required. Never use independent braking during transport.

Always drive at a proper speed relative to local conditions and ensure that your speed is low enough for an emergency stop.

Reduce speed prior to turns to avoid the risk of overturning.

Keep speed to a minimum.

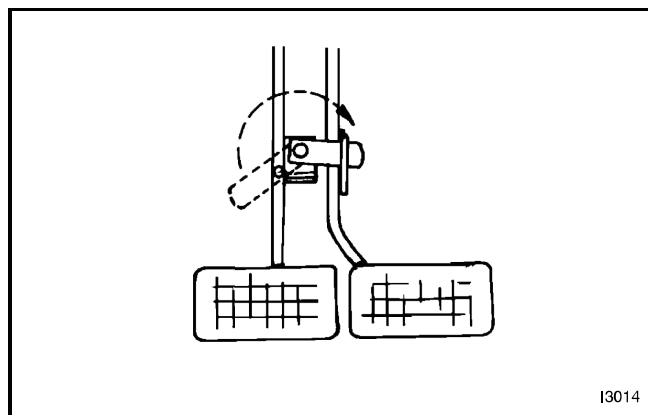

I3014

FIG. 16

FIG. 17: Always keep the tractor in gear to provide engine braking when going downhill. Do not coast.

Avoid sudden or heavy brake applications when operating in wet, muddy or icy ground conditions, or on loose surfaces such as sand or gravel.

Sudden or heavy braking during turns increases the tendency to over steer. This effect is more pronounced with trailed equipment.

Keep a firm grip on the steering wheel at all times, with the thumbs clear of the spokes when driving the tractor.

Remain seated in operator's seat.

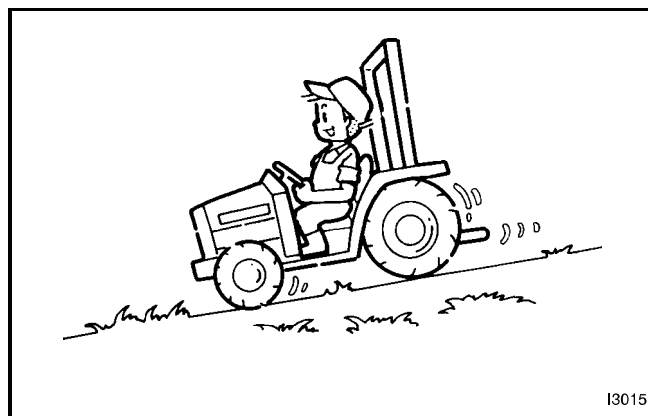

I3015

FIG. 17

SAFETY

FIG. 18: In the event of an overturn, hold the steering wheel firmly and keep your seat belt fastened. **DO NOT** attempt to leave the seat until the tractor has come to rest.

Watch for holes, rocks, or other hidden hazards. **ALWAYS** inspect area prior to operation.

Be observant of the operating area and terrain.

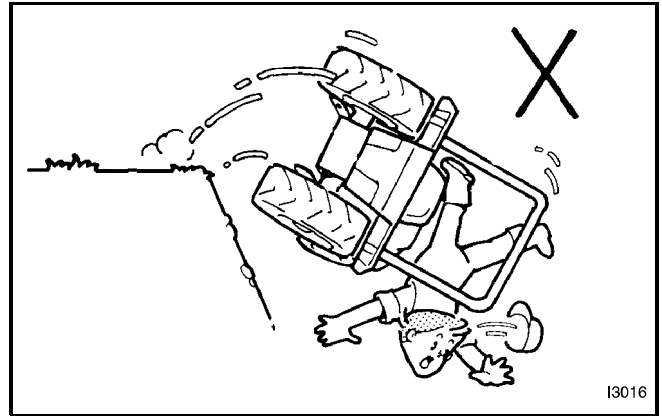

FIG. 18

FIG. 19: **DO NOT** operate near edge of banks. Setback distance from bank should equal, or exceed, the overall height of the bank.

Whenever possible, travel directly up or down slopes, keeping the heavy end of the tractor on the uphill side. If necessary to cross a steep slope, avoid turning uphill. Slow down and make a wide turn.

DO NOT operate on steep slopes as overturn may result.

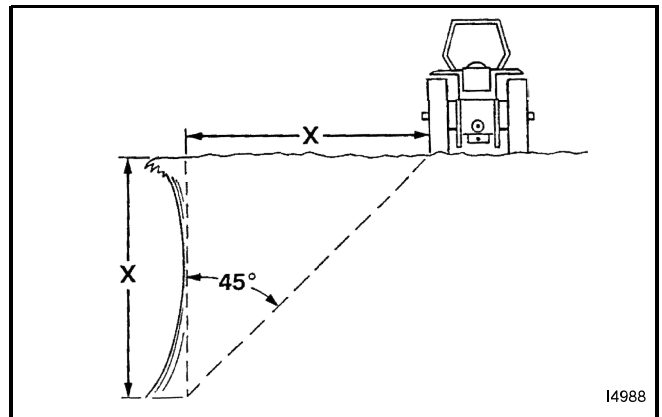

FIG. 19

FIG. 20: Pull only from the approved drawbar.

Towing or attaching to other locations may cause the tractor to overturn.

Use a chain with towed implements. A chain connecting the tractor to the implement will help control pull-type equipment should it accidentally separate from the drawbar.

Always attach the chain to the tractor drawbar support.

Provide only enough slack in the chain to permit turning. See your dealer for a chain with strength rating equal to or greater than the gross weight of the towed machine.

For towed equipment **WITHOUT** brakes, **DO NOT** tow equipment at speeds over 32 kph (20 mph). **DO NOT** tow equipment that, when fully loaded, weighs more 1.5 times the weight of the towing unit.

For towed equipment **WITH** brakes, **DO NOT** tow equipment at speeds over 40 kph (25 mph). **DO NOT** tow equipment that, when fully loaded, weighs more than 4.5 times the weight of the towing unit.

Stopping distance increases with speed and weight of towed loads, and on hills and slopes. Towed loads with or without brakes, that are too heavy for the tractor or are towed too fast, can cause loss of control. Consider the total weight of the equipment and its load.

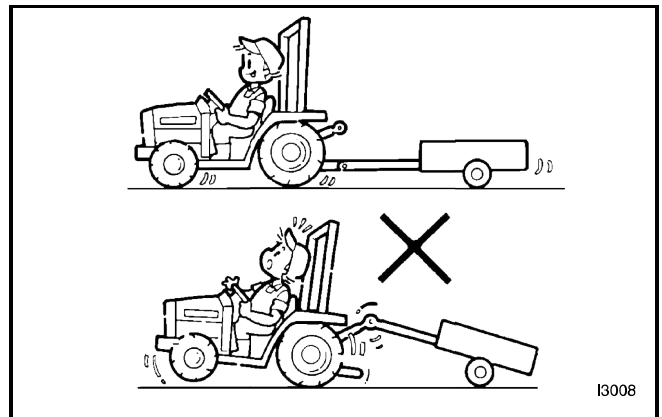

FIG. 20

FIG. 21: When using a loader attachment, to avoid serious injury or death due to falling loads resulting from inadvertent raising or roll-back of the loader, **DO NOT** connect loader hydraulics to any tractor auxiliary valve that has detents which cannot be locked out or removed, except for the float function in the loader lower circuit. If the tractor is equipped with such a valve, a dedicated, properly configured loader valve **MUST** be installed.

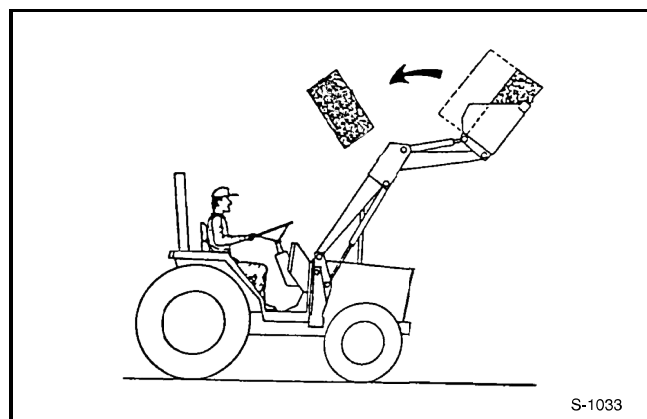

FIG. 21

S-1033

TRAVEL ON PUBLIC ROADS

FIG. 22: When driving the tractor and implement on the road or highway use flashing amber warning (hazard) lights and the Slow Moving Vehicle (SMV) identification emblem when required by local traffic regulations.

The use of flashing amber (hazard) lights is acceptable in most localities. However, some localities may prohibit their use. Local laws should be checked for all highway lighting and marking requirements.

Make sure reflectors are correctly installed, in good condition, and wiped clean. Be sure the SMV emblem is clean, visible, and correctly mounted on the rear of the machine.

Make sure SMV emblem, reflectors, tail lights and flashing amber warning lights are visible and not obscured by towed loads or attachments.

Know the route you are going to travel.

Familiarize yourself with, and obey, all laws appropriate to your tractor. Observe all local or national regulations regarding the road speed of your tractor.

Lock brake pedals together (if equipped with dual brake pedals).

Raise implements to transport position and lock in place. Place all implements into narrowest transport configuration.

Disengage the PTO and differential lock.

Use caution when towing a load at transport speeds especially if the towed equipment is **NOT** equipped with brakes. When towing a load, start braking sooner than normal and slow down gradually.

With towed implements, make sure you use a proper hitch pin with a clip retainer. Use recommended safety chain.

Be aware of the overall width and length of the machine. Be careful when transporting the machine on narrow roads and across narrow bridges.

Use extreme caution when transporting on slippery roads.

Drive defensively. Anticipate what other drivers might do.

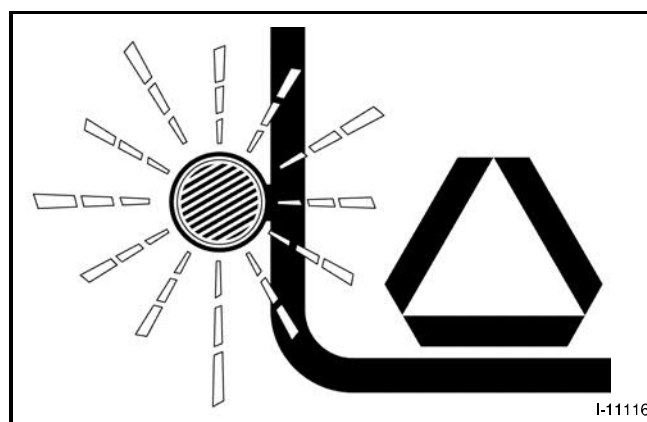

FIG. 22

I-11116

SAFETY

Be aware of other traffic on the road. Keep well over to your own side of the road and pull over, whenever possible, to let faster traffic pass.

Wait for traffic to clear before entering a public road. Stay out of the path of oncoming traffic.

DO NOT attempt to pass at any intersection. Beware of blind intersections. Slow down until you have a clear view.

Slow down for turns and curves. Make wide, gentle turns. Signal your intent to slow, stop or turn.

Shift to lower gear before going up or down hills.

Keep tractor in gear. DO NOT coast with the clutch disengaged or transmission in neutral.

Watch out for overhead obstructions.

MAINTENANCE

FIG. 23: DO NOT service the tractor while the engine is running or hot, or if the tractor is in motion.

DO NOT rely on the tractor hydraulics to hold the tractor or an implement in a raised position for service or maintenance. Always use adequate blocking to keep equipment from falling or lowering unexpectedly.

NOTE: When making major repairs or complicated adjustments, it is recommended that you consult your dealer and have the work carried out by trained personnel.

Keep the tractor properly maintained. Do not operate a tractor when it is broken or has missing parts. Make sure that the maintenance procedures in this manual are completed before using the tractor.

Check all controls regularly and adjust where necessary. Make sure that the brakes are evenly adjusted.

Periodically check all nuts and bolts for tightness, especially wheel hub and rim nuts.

Hydraulic System

FIG. 24: Escaping hydraulic fluid under high pressure can be almost invisible but can penetrate the skin causing serious injury.

Fluid injected into the skin must be surgically removed within a few hours. If not treated immediately, serious infection or reaction can develop. See a doctor familiar with this type of injury immediately.

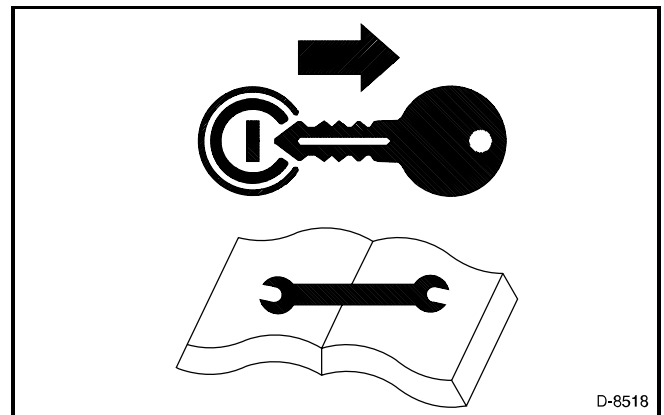

FIG. 23

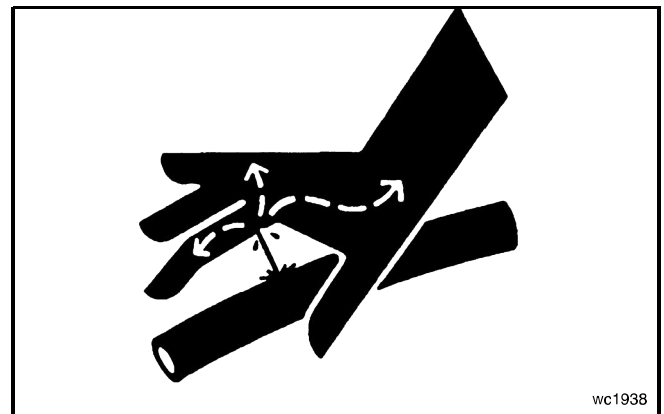

FIG. 24

Thank you so much for reading.
Please click the “Buy Now!”
button below to download the
complete manual.



After you pay.

You can download the most
perfect and complete manual in
the world immediately.

Our support email:

ebooklibonline@outlook.com