

---

**MF 1531 Tractor  
Operator's Manual  
1857 712 M1**

Operator's Manual



---

# MASSEY FERGUSON®

## MF1531 Tractor

### Contents

Safety Alert Symbol	1
Safety Messages	1
Informational Messages	1
Safety Signs	2
A Word To The Operator	2
Operator's Manual	3
Prepare For Operation	3
Roll-Over Protective Structure (ROPS)	3
Operation	4
Travel on Public Roads	9
Maintenance	10
Hydraulic System	10
Electrical System	11
Fuel System	12
Cooling System	12
Wheels and tyres	13
Replacement Parts	13
Safety Signs	14
Introduction	19
Machine Identification	20
Major Components	22
Instruments and Controls	23
Instrument Panel	24
Main Switch	24
Indicator Light Strip	25
Coolant Temperature Gauge	25
Tachometer	25
Fuel Gauge	26
Light/Turn Switch	26
Flashing Warning Lamp Switch	26
Turn/Warning Indicator Lights	27
Power Take-Off (PTO) Switch	27
Brakes	28
Brake Pedal	28
Break-In Period	29
Starting the Tractor	29
Pre-Start Inspection	29
Normal Starting	30
Cold Weather Starting	31
Warm Up Period	31
Restarting Warm Engine	31
Operator Observations	31
Starting Circuit Operation	32
Engine Speed Controls	33
Hydrostatic Transmission	33
Range Shift Lever	33
Hydrostatic Control Pedals	33
Hydrostatic Control Lever	34
Stopping the Tractor	34
Ground Speed Chart	35
Parking the Tractor	35
Differential Lock	36
Four-Wheel Drive	36
Power Take-Off (PTO)	37
Rear PTO Shaft	37
Mid PTO Shaft (If Equipped)	38
PTO Operating Controls	38
PTO Operation	39
Three-Point Hitch	40
Position Control	41
Draft Control (Optional)	41

---

Lowering Rate Control Knob	-42
Rear Linkage	-43
Attaching Implements	-44
Detaching Implements	-45
Drawbar	-46
Roll-Over Protective Structure (ROPS)	-46
Comfort Adjustments	-47
Seat Adjustment	-47
External Auxiliary Hydraulics (Option)	-47
Inspection and Maintenance Chart	-49
Torque Chart	-50
Specifications and Capacities	-50
Engine Oil	-50
Engine Coolant	-50
Fuel Tank	-50
Transmission and Differential Housing	-51
Front Axle	-51
Grease Fittings	-51
Lubrication/Fill Points	-51
Service Access	-52
Opening/Closing Hood	-52
Removing/Reinstalling Side Covers	-52
Lubrication Details	-53
Grease Fittings	-53
Engine Oil and Filter	-53
Transmission Oil and Filter	-54
Front Axle Oil	-56
Cooling System	-57
Engine Air Cleaner	-58
Cleaning/Replacing Air Cleaner Filter Element	-58
Fuel System	-60
Fuel Filter	-60
Air-Bleed Fuel System	-61
Hand Throttle Lever	-61
Electrical System	-62
Battery	-62
Neutral Start System	-64
Wiring/Fuse Arrangement	-64
Wiring Diagrams	-65
Brake Adjustment	-69
Hydrostatic Pedal Adjustment	-70
Wheels and tyres	-70
Tyre Inflation Pressures	-70
Wheel Bolt Torque	-70
Front Wheel Alignment	-71
Front Wheel Spacing	-71
Rear Wheel Spacing	-71
Steering Free-Play	-72
Front Axle End-Float	-72
Clutch Housing Plug	-72
Storage	-73
Engine	-75
Brakes	-78
Hydraulic System	-79
Electrical System	-81
Transmission	-82
Engine	-83
Transmission	-83
Power Take-Off (PTO)	-83
Hydraulic System	-84
Electrical System	-84
Capacities	-84
Maximum Load Capacity	-85
General Dimensions	-86
Canopy	-87
Engine Block Heater	-87

---

---

Rear Work Light(s) .....	87
Rear Weight Frame .....	87
Hang-On Weights .....	87
Single or Two Spool Auxiliary Valve .....	87
Implements and Attachments .....	87
Assembling the tractor .....	89
INDEX .....	91

---

# SAFETY

## SAFETY ALERT SYMBOL

**FIG. 1:** The safety alert symbol means ATTENTION! BECOME ALERT! YOUR SAFETY IS INVOLVED!

Look for the safety alert symbol both in this manual and on safety signs on this machine. The safety alert symbol will direct your attention to information that involves your safety and the safety of others.



FIG. 1

## SAFETY MESSAGES

**FIG. 2:** The words DANGER, WARNING or CAUTION are used with the safety alert symbol. Learn to recognize these safety alerts and follow the recommended precautions and safety practices.

 **DANGER:** Indicates an imminently hazardous situation that, if not avoided, will result DEATH OR VERY SERIOUS INJURY.

 **WARNING:** Indicates a potentially hazardous situation that, if not avoided, could result in DEATH OR SERIOUS INJURY.

 **CAUTION:** Indicates a potentially hazardous situation that, if not avoided, may result in MINOR INJURY.



FIG. 2

## INFORMATIONAL MESSAGES

The words IMPORTANT and NOTE are not related to personal safety, but are used to give additional information and tips for operating or servicing this equipment.

**IMPORTANT:** Identifies special instructions or procedures which, if not strictly observed, could result in damage to or destruction of the machine, process, or its surroundings.

**NOTE:** Identifies points of particular interest for more efficient and convenient repair or operation.

---

## SAFETY SIGNS



**WARNING: DO NOT** remove or obscure Danger, Warning or Caution signs. Replace any Danger, Warning or Caution signs that are not readable or are missing. Replacement signs are available from your dealer in the event of loss or damage. The actual location of the safety signs is illustrated at the end of this section.

If a used machine has been purchased, make sure all safety signs are in the correct location and can be read.

See Safety Sign Location of this section for illustrations.

Replace any safety signs that can not be read or are missing. Replacement safety signs are available from your dealer.

## A WORD TO THE OPERATOR

**FIG. 3:** It is YOUR responsibility to read and understand the safety section in this book before operating this machine. Remember that YOU are the key to safety. Good safety practices not only protect you, but also the people around you. Study the features in this book and make them a working part of your safety program. Keep in mind that this safety section is written only for this type of machine. Practice all other usual and customary safe working precautions, and above all **REMEMBER - SAFETY IS YOUR RESPONSIBILITY. YOU CAN PREVENT SERIOUS INJURY OR DEATH.**

This safety section is intended to point out some of the basic safety situations that may be encountered during the normal operation and maintenance of your machine, and to suggest possible ways of dealing with these situations. This section is **NOT** a replacement for other safety practices featured in other sections of this book.

***IMPORTANT:** This manual covers general safety practices for this machine. It must always be kept with the machine. After using this manual, return it to the container on the machine.*



**WARNING:** An operator should not use alcohol or drugs which can affect their alertness or coordination. An operator on prescription or 'over the counter' drugs needs medical advice on whether or not they can properly operate machines.

Do not let anyone operate this machine without thorough instruction.

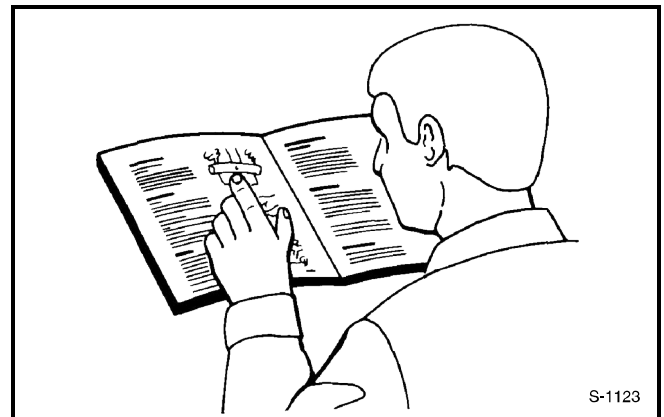

**FIG. 3**

S-1123

---

## OPERATOR'S MANUAL

The photos, illustrations, and data used in this manual were current at the time of printing, but due to possible in-line production changes, your machine can vary slightly in detail. The manufacturer reserves the right to redesign and change the machine as necessary without notification.



**WARNING: In some of the illustrations or photos used in this manual, panels or guards may have been removed for clarity. Never operate the machine with any panels or guards removed. If the removal of panels or guards is necessary to make a repair, they MUST be replaced before operation.**

This operator's manual is compiled to cover safe working practices that are associated with the basic tractor operation.

The manual does not cover all operation and safety instructions relevant to all known implements and attachments that may be used at the time of tractor delivery or at some future date.

It is essential that operators use and understand the relevant instruction manuals of all implements and attachments.

## PREPARE FOR OPERATION

Read this manual completely and make sure you understand the controls. Know the positions and operations of all controls before you operate this machine. Check all controls in an area clear of people and obstacles before starting your work.

All equipment has a limit. Make sure you understand the speed, brakes, steering, stability, and load characteristics of this machine and your tractor before you start.

Make sure your machine has the correct equipment needed by the local regulations.

## ROLL-OVER PROTECTIVE STRUCTURE (ROPS)

Roll-over protective structure (ROPS) is effective in reducing injuries during overturns. Overturning a tractor without ROPS or with the ROPS folded down can result in serious injury or death. Operate with ROPS folded down only when conditions make this necessary. Return ROPS to upright, locked position as soon as conditions permit.

DO NOT weld, drill or alter the ROPS.

If the tractor has been rolled over or the ROPS frame has been damaged in any manner, the ROPS must be replaced. Do not attempt to repair a damaged ROPS. If damage does occur, consult your Dealer and replace all damaged parts.

Before using the tractor ensure that the ROPS frame is not damaged and that it is securely fastened to the tractor

DO NOT attach chains, ropes or cables to the ROPS for pulling purposes - damage to the ROPS and/or overturn of the tractor may result. Always pull from the tractor drawbar.

Observe all recommendations and instructions regarding the installation of covers or roofs which are used as SUNSHIELDS ONLY and do not afford the operator protection from falling objects.

## OPERATION



**DANGER: DO NOT attempt to unplug the hydraulic connections, or adjust an implement with the engine running or the PTO drive in operation. To do so may result in very serious injury or death.**

Keep emergency telephone numbers for immediate access.

**FIG. 4:** Wear all protective clothing and personal protective equipment issued to you or called for by job conditions. Wear approved hearing protection whenever operating the machine as required by country/local regulations. DO NOT wear loose clothing, jewelry, or other items that could entangle in moving parts. Tie up long hair that also could entangle in moving parts. Always keep hands, feet, hair, and clothing away from moving parts.

Protective equipment that may be needed:

- A hard hat.
- Safety glasses, goggles, or face shield.
- Hearing protection.
- Respirator or filter mask.
- Inclement weather clothing.
- Reflective clothing.
- Heavy gloves (neoprene for chemicals, leather for rough work).
- Protective footwear.
- Other specialized protective gear.

Specific safety equipment may be required for the application of fertilizers, pesticides, etc. Follow all recommendations given by the chemical supplier and manufacturer.

DO NOT wear loose clothing, as this may catch on moving parts of the tractor or implement causing injury.

**FIG. 5:** Always wear the seat belt, correctly adjusted, during tractor operation unless operating with the ROPS folded down. Do not wear the seat belt when ROPS is folded down.

Check the seat belt for damage. A damaged seat belt must be replaced.

The seat belt for this tractor is located beside the seat. Sit in the seat, adjust the seat belt length, and fit the latch into the buckle.

Release the seat belt by pushing down on the buckle. Properly store the seat belt beside the seat.

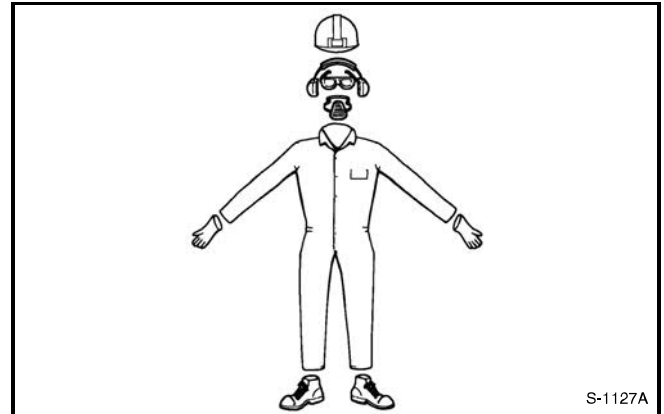

**FIG. 4**

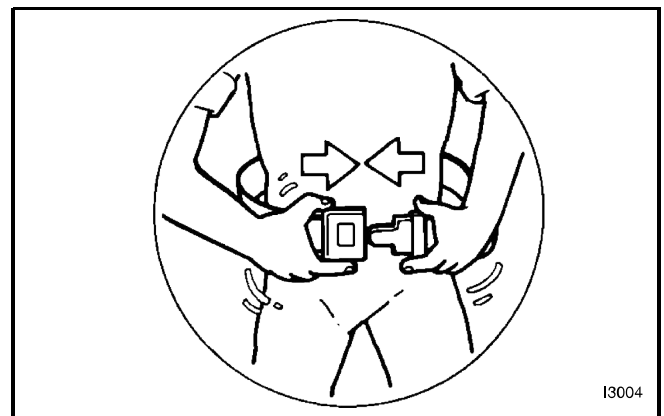

**FIG. 5**



**FIG. 6:** A fire extinguisher and first aid box should be carried with the tractor or be kept readily available at all times. Consult your Dealer.

Note where fire extinguishers and first-aid or emergency equipment are kept and get to know where to get help in a hurry. Make sure you know how to use this equipment.

Clear the area before operation.

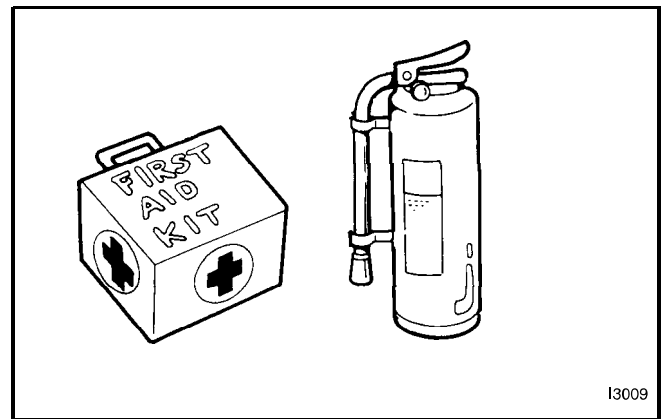

**FIG. 6**

**FIG. 7:** DO NOT carry passengers

DO NOT permit others to ride on the tractor or on any implement or attachment connected to, or installed on tractor.



**FIG. 7**

**FIG. 8:** Beware of bystanders, particularly children. Always look around to make sure that everyone is clear before starting the engine or moving the tractor. This is particularly important with higher noise levels as you may not hear people shouting.

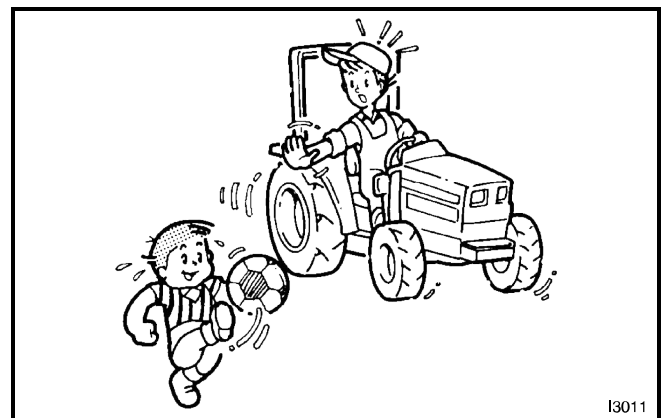
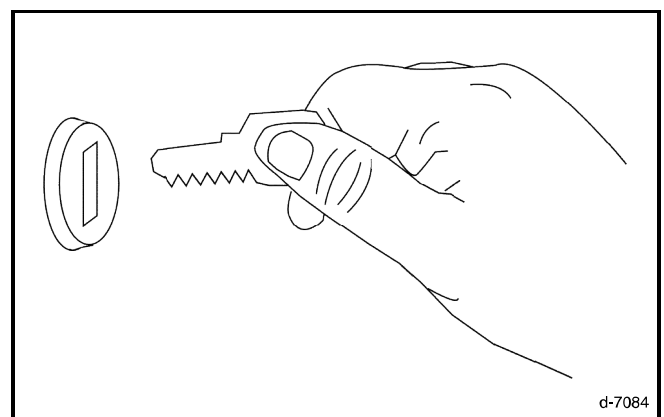

**FIG. 8**

**FIG. 9:** When dismounting and/or leaving the operator's seat FOR ANY REASON, always:

1. Disengage PTO drive.
2. Lower implements, attachments to ground.
3. Shut off engine.
4. Apply parking brake securely.
5. Select transmission lever(s) to neutral.
6. Remove the key.

Do not attempt to service machine, clear obstructions or unplug blockages with the engine running. Always shut off engine and allow all motion to cease.



**FIG. 9**

**FIG. 10:** Always start the engine from the operator's seat with the transmission lever and the PTO lever in neutral.

DO NOT bypass the starting circuit by shorting across the terminals of the starter motor to start the engine. This may cause the tractor to move suddenly.

Periodically check starting circuit to make sure all system components operate correctly.

If the starting system does not work, consult your Dealer immediately.

Never attempt to start the engine while standing beside the tractor.

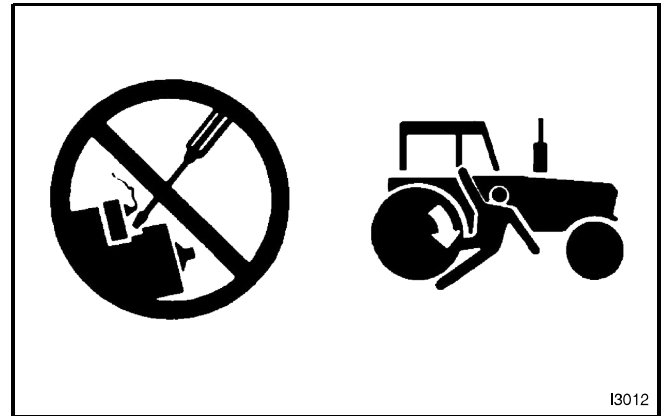

**FIG. 10**

**FIG. 11:** Keep clear of all rotating driveline components. Be especially observant of implement areas of discharge, intake or other mechanical motion.

Make sure rotating guards turn freely.

A loose yoke can slip off the tractor PTO shaft and result in injury to persons or damage to the machine.



**FIG. 11**

**FIG. 12:** Keep all shields in place.

Rear PTO (Power Take-Off) master shield (1) must be correctly installed at all times. PTO shaft cover(s) must be installed when PTO driveline is not in use.

Do NOT use PTO adapters. PTO shaft adapters, reducers and/or extensions extend the implement drive shaft coupler and universal joint beyond the protection of the PTO master shield.

Reduce PTO speed slowly. When stopping any PTO driven machine, idle the engine to reduce the PTO speeds before disengaging.

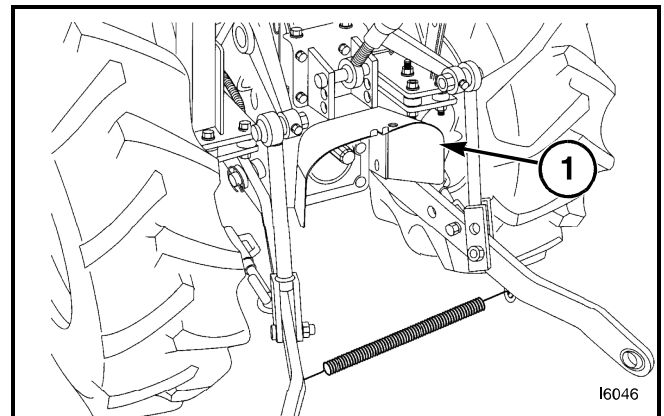
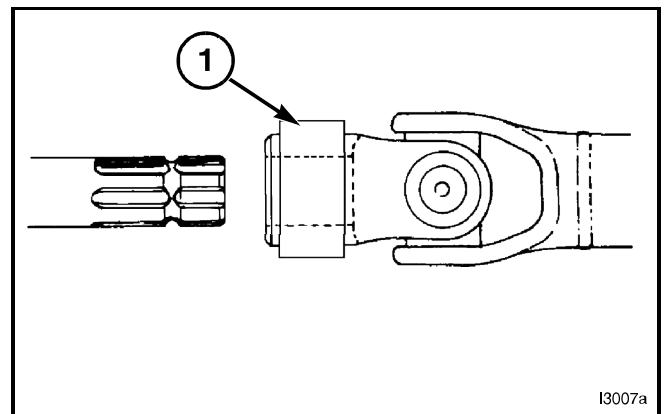

**FIG. 12**

**FIG. 13:** Implement drive shaft coupler (1) must securely lock to and be retained by annular groove on tractor PTO shaft.

Always disengage PTO, park the tractor, shut off engine and remove the key before:

- Connecting or disconnecting the implement drive shaft.
- Adjusting the PTO driveline or PTO-driven machine.
- Cleaning, unplugging or servicing PTO-driven machine.



**FIG. 13**

**FIG. 14:** Starting fluid must only be used when an ether-start aid is fitted as original equipment by the manufacturer or when installed by a dealer as an approved accessory.

When tractors are equipped with glow plugs or other heating device, these **MUST** be removed prior to the usage of starting fluid or ether-starting aid.

Use of starting fluid on engine equipped with glow plugs can result in severe engine damage.



**FIG. 14**

**FIG. 15:** If in an enclosed area, vent the exhaust to the outside. Always start and operate engine in a well-ventilated area.

Do not tamper with or modify the exhaust system with unapproved extensions

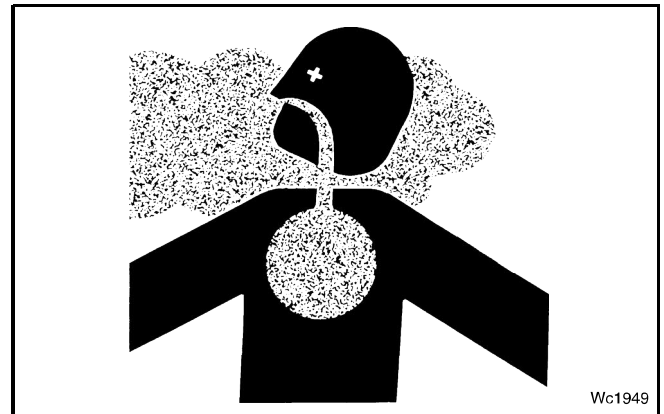

**FIG. 15**

**FIG. 16:** On models with independent brake pedals, keep the brake pedals latched together at all times unless independent braking is required. Never use independent braking during transport.

Always drive at a proper speed relative to local conditions and ensure that your speed is low enough for an emergency stop.

Reduce speed prior to turns to avoid the risk of overturning.

Keep speed to a minimum.

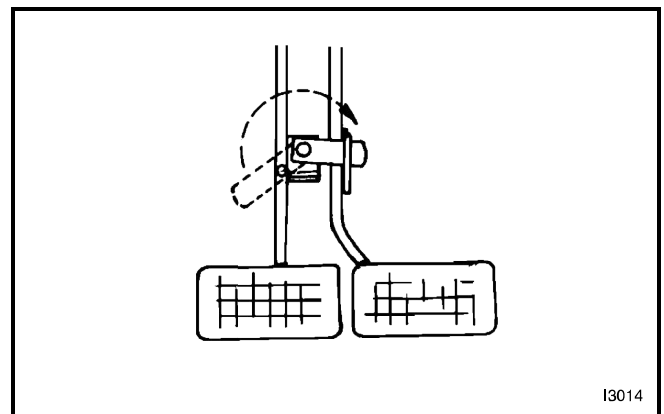

**FIG. 16**

**FIG. 17:** Always keep the tractor in gear to provide engine braking when going downhill. Do not coast.

Avoid sudden or heavy brake applications when operating in wet, muddy or icy ground conditions, or on loose surfaces such as sand or gravel.

Sudden or heavy braking during turns increases the tendency to over steer. This effect is more pronounced with trailed equipment.

Keep a firm grip on the steering wheel at all times, with the thumbs clear of the spokes when driving the tractor.

Remain seated in operator's seat.

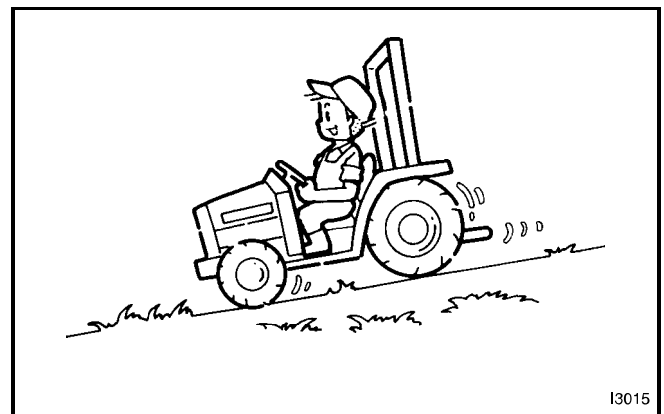

**FIG. 17**

Thank you so much for reading.  
Please click the “Buy Now!”  
button below to download the  
complete manual.



After you pay.

You can download the most  
perfect and complete manual in  
the world immediately.

Our support email:

[ebooklibonline@outlook.com](mailto:ebooklibonline@outlook.com)