

FENDT
5270C
5270C-AL
6300C
6300C-AL

**WORKSHOP
MANUAL**

CONTENT

	Sections
- GENERAL INFORMATION	00
- ENGINE	10
- LIVE PTO	14
- TRANSMISSION	21
- FRONT DRIVE AXLE	25
- HYDROSTATIC TRANSMISSION	29
- BRAKES AND CONTROL	33
- HYDRAULIC SYSTEMS	35
- STEERING	41
- AXLE AND WHEELS	44
- CAB CLIMATE CONTROL	50
- ELECTRICAL SYSTEMS	55
- ATTACHMENTS / HEADERS	58
- PRODUCT FEEDING	60
- THRESHING	66
- SEPARATION	72
- STRAW CHOPPER	73
- CLEANING	74
- GRAIN STORAGE	80

	MODEL IDENTIFICATION
FENDT	
<i>5270C</i>	5
<i>5270C-AL</i>	5AL
<i>6300C</i>	6
<i>6300C-AL</i>	6AL

COMBINE MODELS

INITIALS	ENGINE CV/kW	STRAW WALKER NO.	MCS DEVICE	PFR DEVICE	GSA DEVICE	MACHINE LEVELLING DEVICE
5	275 / 203	5	YES	YES	YES	NO
5 AL	275 / 203	5	YES	YES	YES	YES
6	300 / 224	6	YES	YES	YES	NO
6 AL	300 / 224	6	YES	YES	YES	YES

IMPORTANT

**THE COMBINE ASSEMBLY, AT THE ARRIVAL TO THE DEALER OR IMPORTER, HAS TO BE MADE FOLLOWING THE "ASSEMBLY INSTRUCTION BOOK".
BEFORE THE DELIVERY OF COMBINE TO THE CUSTOMER, THE PRE-DELIVERY INSPECTION HAS TO BE MADE FOLLOWING THE P.D.I. MODULE INSTRUCTIONS AS THE ONE REPORTED BELOW.**

PRE-DELIVERY INSPECTION
Combines

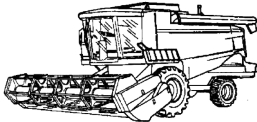
Model	<hr/>	Owner's Name	<hr/>
Serial No.	<hr/>	Address	<hr/>
Model	<hr/>	Telephone	<hr/>
Combine Serial No.	<hr/>	Fax	<hr/>
Engine Serial No.	<hr/>		
Table Type	<hr/>		
Table Size	<hr/>		
Table Serial No.	<hr/>		

The following items, if applicable, must be checked and, where necessary, rectified by the Dealer before delivery.

	CHECKED	COMMENTS
TABLE		
1. Check table and table trailer for any transport damage		
2. Check all belt and chain drives are tensioned correctly		
3. Ensure knife, auger and reel all operate correctly		
4. On Powerflow tables check belts track correctly		
5. Ensure table attaches properly and all connections operate correctly		
6. Assemble parts removed for transport; e.g. dividers, etc.		
MAIN CROP ELEVATOR		
7. Check tension and operation of main crop elevator (chains and slats)		
8. Check function of power feed roller (on models where fitted)		
9. Ensure stone trap operates correctly		
10. Check operation of the table reverse mechanism (at low engine speed)		
THRESHING AREA		
11. Ensure concave(s) are free to move and can be adjusted correctly		
12. Inspect condition of drives to cylinder, rear beater and rotary separator (if fitted)		
STRAW WALKERS		
13. Check condition of the drive and the mounting bushes / bearings		
CLEANING AREA		
14. Check sieves will operate through their full range of adjustments		
15. Inspect condition of drives to shaker shoe and fanning mill		
16. Ensure all sealing devices are in place and functional		
CROP ELEVATORS, AUGERS & TANK		
17. Check drives of all clean grain elevators and augers, including unloading system		
18. Check unloading auger angle gear oil		

	CHECKED	COMMENTS
SPREADER / CHOPPER		
19. Check security and positioning of chaff spreader in / out of operation		
20. Check drive mechanism and function of chaff spreader		
21. Check engagement and function of straw chopper and straw deflectors		
TRANSMISSION & BRAKES		
22. Check gearbox for oil leaks and correct oil level		
23. Check final drives for oil leaks and correct oil level		
24. Check track frame outer support oil level (rice combines only)		
25. Check hydrostatic oil level in reservoir, look for signs of leaks on pump, motor, hoses and cooler (if fitted)		
26. Ensure gear selection and hydrostatic transmission work correctly		
27. Check chain tension of tracks (rice combine only)		
28. Check braking system for operation, balance and adjustment, including parking brake		
29. Check brake pipes for any leakage signs and brake fluid reservoir level		
HYDRAULIC SYSTEM		
30. Check oil level in hydraulic reservoir(s)		
31. Operate all hydraulic systems through their normal range, rectify all leaks and restrictions in either speed or travel, note any excess pump noise		
32. Check function of any levelling systems		
ELECTRICAL SYSTEM		
33. Check battery electrolyte level and terminal tightness, ensure isolator switch functions ok		
34. Check tightness of all electrical harness connections and earth points		
35. Check function of all work / inspection lights (grain tank, sieves, etc.)		
CHAINS & BELTS		
36. Check tension of all chains and belts, including engagement tensioners		
37. Ensure any safety / protection devices are free to operate correctly (slip clutches, shear bolts, torque limiters, etc.)		
WHEELS & STEERING		
38. Check steering column adjusters, operate the steering to full lock in each direction, check for smooth operation and the function of the stops		
39. Check tyre pressures plus tightness and presence of all wheel nuts / studs		

	CHECKED	COMMENTS
ENGINE		
40. Check tightness of all engine air intake hose / pipe connections and filters		
41. Check engine oil level		
42. Check cooling system level and ensure all hoses / connections are tight		
43. Check sufficient fuel in tank to run for 1 hour and drain water trap		
44. Check for any signs of leaks of fuel, oil or coolant		
45. Check security of engine mountings		
46. Ensure the tension of fan, alternator(s) and compressor drive belts is correct		
47. Ensure engine starts / stops and operates through min to max engine revs correctly		
48. Ensure hoses, pipes or wiring are not fouling on the exhaust or any moving items		
GENERAL MACHINE		
49. Inspect table and threshing mechanism running at low speeds, then operate at full speed for 30 minutes		
50. Check operation of all other optional equipment, electric sieves, vertical knife, etc.		
51. With machine stopped, inspect for any damage, leaks or loose hardware		
52. Clean combine and inspect all paintwork (sheet metal and other) and check safety guards and decals are in place		
53. Lubricate all grease points		
54. Ensure items such as tool boxes, literature packs, etc., conform to machine / market specifications.		
OPERATOR ENVIRONMENT		
55. Check correct operation of all controls, switches and warning lights / systems		
56. Check any on-board computer systems and calibrate any monitoring functions		
57. Inspect general condition of cab including seat, radio, wipers, glass, trim, mirrors, air conditioning, heater / blower, door, locks, ladder, etc.		
58. Check function of all driving and directional signal lights.		
Signature (Service Engineer)	_____	
Date	_____	
December 2004		Publication No. LA327191010 M1 English

Dealer Service Schedule

X = Both Ranges A = 5A-5B-6A only B = 5-6-5AL-6AL only

	50 Hours	225 Hours	450 Hours	900 Hours	End of Season 1	End of Season 2	End of Season 3	End of Season 4
Table Header								
Grease the knife drive gearbox.	X	X	X	X	X	X	X	X
Grease the knife head.	X	X	X	X	X	X	X	X
Check knives and fingers.					X	X	X	X
Check auger, auger fingers and flights.					X	X	X	X
Check auger slip clutch.					X	X	X	X
Check all drive belts and chains.	X				X	X	X	X
Check reel belt drive variator hubs.					X	X	X	X
Check reel tine bars, spiders and bearings.					X	X	X	X
Check correct function of the GSA (Auto Level).					X	X	X	X
Main Crop Elevator								
Fit any table stabilising devices and detach cutting table from the rump of the combine.					X	X	X	X
Check condition of Prepare & Feeding Roller (PFR system).					B	B	B	B
Check condition of elevator slats and conveyor chains.					X	X	X	X
Check movement and condition of lower feed roller.					X	X	X	X
Inspect and reset slip clutch.					X	X	X	X
Check condition and tensioning of elevator and table drive chain.	X	X	X	X	X	X	X	X
Check condition of top feeder drive shaft.					X	X	X	X
Check operation of stone trap.					X	X	X	X
Check operation and condition of the table reverse mechanism (at low engine speed).					X	X	X	X

	50 Hours	225 Hours	450 Hours	900 Hours	End of Season 1	End of Season 2	End of Season 3	End of Season 4
Drum, Concave and Threshing area								
Check condition of the drive & speed variator mechanism to drum.					X	X	X	X
Check condition of the cylinder and rasp bars for wear / damage.					X	X	X	X
Inspect condition of concave(s) rub bars and wires.					X	X	X	X
Ensure concave(s) are free to move, can be fully adjusted & the clearance is correct.					X	X	X	X
Check condition of the drive to the Rotary Separator (MCS).					B	B	B	B
Check condition & clearance of the Rotary Separator (MCS) & also for wear / damage.					B	B	B	B
Check condition of cylinder door and seals.					X	X	X	X
Inspect rear beater for damage / wear and condition of its drive.					X	X	X	X
Check rear beater & concave curtain condition.					X	X	X	X
Check all drive belts and chains.	X			X	X	X	X	X
Check condition of straw walkers and sieves.					X	X	X	X
Check sealing strips for grain pan and shaker shoe.					X	X	X	X
Straw Walkers								
Check condition of the drive mechanism.					X	X	X	X
Inspect for wear the straw walker crankshafts and bearings / blocks.					X	X	X	X
Check condition and adjustment of the straw walker curtain(s).					X	X	X	X
Check condition of the straw walkers and risers if fitted.					X	X	X	X
Check on condition of sealing rubbers.					X	X	X	X
Check condition of sealing rubbers installed for maize.					X	X	X	X
Check security and position of grain loss sensors.					X	X	X	X
Check on condition of returns pan.					X	X	X	X
Check the condition of all drives and mounting bushes / bearings.	X			X	X	X	X	X

	50 Hours	225 Hours	450 Hours	900 Hours	End of Season 1	End of Season 2	End of Season 3	End of Season 4
Cleaning Area								
Check sieves will operate through full range of adjustment.					X	X	X	X
Remove sieves and grain pan and check for damage. Protect from rusting.					X	X	X	X
Inspect condition of shaker shoe and grain pan frame for cracks or damage.					X	X	X	X
Inspect mounting bushes / bearings for wear.	X			X	X	X	X	X
Inspect belt, pulley and pitman drives to sieves.	X			X	X	X	X	X
Check adjustments and timing of shaker shoe drives.					X	X	X	X
Inspect condition of all sealing strips.					X	X	X	X
Check condition and operation of cleaning fan, including drive belt.					X	X	X	X
Check condition and adjustment of air deflectors, fan blades and sealing strips.					X	X	X	X
Inspect condition of cross augers.					X	X	X	X
Crop Elevators, Augers and Tank								
Check condition of drives to grain elevators.		X	X	X	X	X	X	X
Inspect condition of conveying chains and paddles.		X	X	X	X	X	X	X
Check elevator top and bottom for wear.					X	X	X	X
Check condition and function of bubble up auger.					X	X	X	X
Check condition of grain tank discharge system.					X	X	X	X
Check grain tank and unloading auger for leaks.					X	X	X	X
Check discharge auger angle gear oil.					X	X	X	X
Inspect general condition of grain tank including 'full' sensors.					X	X	X	X
Inspect returns system slip clutch.					X	X	X	X
Inspect and adjust the elevator slip clutch and check condition of the shear bolts for the discharge auger.					X	X	X	X

	50 Hours	225 Hours	450 Hours	900 Hours	End of Season 1	End of Season 2	End of Season 3	End of Season 4
Chaff Spreader and Straw Chopper								
Check security and positioning of chaff spreader in / out of operation.					X	X	X	X
Check chaff spreader rotors for damage.					X	X	X	X
Inspect drive mechanism of chaff spreader.					X	X	X	X
Check condition of the straw chopper rotor and condition of all knives.		X	X	X	X	X	X	X
Check function and condition of straw deflectors.					X	X	X	X
Inspect straw chopper drive and engagement mechanism for wear and adjustment.					X	X	X	X
Change the oil in the main transmission gearbox.			X	X	X	X	X	X
Transmission and Brakes								
Check gearbox for leaks and correct oil level.	X	X						
Inspect final drives for oil leaks and correct oil level.	X	X						
Change the oil in the final drives.			X	X	X	X	X	X
Ensure gear selection and external adjustment is correct.					X	X	X	X
Ensure hydrostatic transmission operates correctly.					X	X	X	X
Look for signs of leakage or damage to hydrostatic pump, motor, hoses and oil cooler.	X	X	X	X	X	X	X	X
Change hydrostatic oil.			X	X	X	X	X	X
Check hydrostatic oil level in reservoir.	X	X						
Change hydrostatic pump filter.			X	X	X	X	X	X
Inspect condition of drive shaft couplers to final drive housings.			X	X	X	X	X	X
Check the track frame, outer support oil level.			B	B	B	B	B	B
Check the track chain tension.			B	B	B	B	B	B
Check parking brake system for operation and adjustment.	X			X	X	X	X	X
Check independent brakes for operation and balance.	X			X	X	X	X	X
Check brake fluid level.	X	X	X	X	X	X	X	X
Change brake fluid and bleed brakes.						X		X
Assess condition of brake shoes / pads for wear.				X	X	X	X	X
Check brake lines / hoses for deterioration.				X	X	X	X	X

	50 Hours	225 Hours	450 Hours	900 Hours	End of Season 1	End of Season 2	End of Season 3	End of Season 4
Hydraulic System								
Check oil level in hydraulic system reservoir(s).	X	X						
Change hydraulic oil.			X	X	X	X	X	X
Change hydraulic oil tank return filter.			X	X	X	X	X	X
Inspect main supply and return hoses for leakage.	X	X	X	X	X	X	X	X
Operate all hydraulic systems through their normal working range and note any restrictions in either speed or travel.					X	X	X	X
Inspect all hydraulic cylinders, hoses and connections for damage or leaks.	X				X	X	X	X
Check function of the levelling system (AL-4).					B	B	B	B
Report any unusual noise or characteristics of the hydraulic pump(s).	X	X	X	X	X	X	X	X
Electrical System								
Check function of all work / inspection lights (Grain Tanks, Sieves, etc.).					X	X	X	X
Check battery electrolyte level and cable connections.				X	X	X	X	X
Inspect general condition of the fuse box for missing or damaged fuses, diodes and relays.					X	X	X	X
Check tightness of all external cable harness connections and common earth points.					X	X	X	X
Inspect cable condition for cracks and chaffing.					X	X	X	X
Check function of the main switch and condition of the main battery and its leads.					X	X	X	X
Examine all actuating motors for correct function and signs of damage.					X	X	X	X

	50 Hours	225 Hours	450 Hours	900 Hours	End of Season 1	End of Season 2	End of Season 3	End of Season 4
Chains, Sprockets, Belts and Pulley								
Visually inspect all belts for signs of wear and damage.					X	X	X	X
Check the tension of all belts and note any belt drives that have limited adjustment left on them.				X	X	X	X	X
Check tension of all belts & inspect for any signs of damage.	X				X	X	X	X
Inspect all pulleys for signs of wear or damage, any misalignment or mounting problems.					X	X	X	X
Ensure split sheave pulleys travel freely and that the belt does not bottom out. Inspect any safety devices built into belt drives, e.g. friction linings, etc.					X	X	X	X
Check the condition and tension of all chain drives.	X			X	X	X	X	X
Report any chain wear / damage or sprocket wear / damage.					X	X	X	X
Lubricate and protect all roller chains.	X			X	X	X	X	X
Inspect all chain idlers, tensioners and guide blocks for wear / damage.				X	X	X	X	X
Wheels and Steering								
Operate the steering to full lock in each direction, check for smooth operation and function of stops.				X	X	X	X	X
Inspect the steering column for correct function and adjustment.					X	X	X	X
Inspect the steering linkage, hoses, ball joints and steering rams.				X	X	X	X	X
Check rear wheel bearings and stub axles for wear.				X	X	X	X	X
Check tightness and presence of all wheel nuts / studs.				X	X	X	X	X
Inspect general condition and pressure of all tyres.				X	X	X	X	X

	50 Hours	225 Hours	450 Hours	900 Hours	End of Season 1	End of Season 2	End of Season 3	End of Season 4
Engine								
Check the safety (inner) and clean the outer air cleaner elements.	X	X						
Change both the safety (inner) and outer air cleaner elements.			X	X	X	X	X	X
Inspect the air intake system for damage and leaks.				X	X	X	X	X
Change engine oil and oil filter(s).	X	X	X	X	X	X	X	X
Check valve tip clearances (replace rocker cover gaskets).				X	X		X	
Change engine crankcase vent filters.			A	A	A	A	A	A
Check level of cooling system and inspect radiator for cleanliness and leaks.	X	X	X	X	X		X	
Change antifreeze in the cooling system plus additive (if supplied).						X		X
Check cooling system hoses and connections are tight.					X	X	X	X
Change fuel sedimentor / water trap element.		X	X	X	X	X	X	X
Replace fuel filters.		X	X	X	X	X	X	X
Clean the fuel tank water trap.	X							
Check the rotary air intake and dust extractor.					X	X	X	X
Check for leaks in oil, fuel & coolant systems.	X	X	X	X	X	X	X	X
Check engine fastening screws on cross beams.	X			X	X	X	X	X
Check engine speed range & min. / max. settings.					X	X	X	X
Inspect and tension fan, alternator and compressor drive belts.					X	X	X	X
Check lubricating pipe for turbocharger.					X	X	X	X
Check general condition of fuel tank.					X	X	X	X
Ensure hoses, pipes or wiring are not fouling exhaust system and pulleys, belts, etc.					X	X	X	X

	50 Hours	225 Hours	450 Hours	900 Hours	End of Season 1	End of Season 2	End of Season 3	End of Season 4
General Machine								
Lubricate all grease points.	X	X	X	X	X	X	X	X
Ensure all table attachment connections operate correctly and safely. (Mechanical, Hydraulic & Electrical).					X	X	X	X
Start engine, check engagement of table and threshing mechanisms.					X	X	X	X
Visually examine combine chassis for any signs of damage.					X	X	X	X
Check for loose bolts (particularly the undercarriage).	X				X	X	X	X
Ensure that all safety guards and safety decals are in place.					X	X	X	X
Advise customer of winter storage procedure, regular starting, etc. and vermin protection.					X	X	X	X
Check all belts and chains that have not already been inspected.				X	X	X	X	X
Check all mechanical/electrical clutches.					X	X	X	X
Check operation of optional equipment, vertical knife/chaff spreader/straw chopper/electrical straw deflectors/GSA/maize header etc. (if fitted).					X	X	X	X

	50 Hours	225 Hours	450 Hours	900 Hours	End of Season 1	End of Season 2	End of Season 3	End of Season 4
Operator Environment								
Check function of the start, stop and throttle controls.					X	X	X	X
Re-set the performed maintenance feature on the computer.					X	X	X	X
Change cab air filters.			X	X	X	X	X	X
Check cab air filters.		X						
Check all instruments & warning systems for correct operation.					X	X	X	X
Check operation of electronic/automatic functions.	X				X	X	X	X
Inspect general condition of cab interior, including seat, radio, etc.					X	X	X	X
Report any problems with cab glass, door, locks, ladder, etc.					X	X	X	X
Check operation of the onboard computer system.					X	X	X	X
Check operation of any monitoring systems, including Datavision.					X	X	X	X
Check condition of in-cab control switches for operation of all general systems such as lights, blowers, windshield wipers, etc.					X	X	X	X
Top up windshield washer reservoir.					X	X	X	X
Check all driving and directional signal lights.					X	X	X	X
Check function of all systems controlled by switches and/or Datavision.					X	X	X	X
Check function of airconditioning system.					X	X	X	X
Replace the receiver dryer.					X	X	X	X
Check cutting height presetting/cutting height control and field pressure control.					X	X	X	X

X = Both Ranges **A** = 5A-5B-6A only **B** = 5-6-5AL-6AL only

NOTE:

Section 00 - GENERAL INFORMATION

GENERAL INSTRUCTION

IMPORTANT NOTE

All maintenance and repair works described in this manual must be carried out only by the AGCO service network, strictly complying with the instructions given and using the required special tools. Anybody carrying out the above interventions without strictly complying with the prescriptions is fully responsible for the occurred damage.

ADJUSTMENT SHIMS

During any adjustment, select the adjustment shims measuring them individually, by a micrometer, and then summing up the detected values: do not rely on the wrong measurement of the complete pack or on the rated value stated for each ring.

ROTARY SHAFT SEALS

For correct rotating shaft seal installation, proceed as follows:

- before assembly, leave the seals in oil bath, for at least half an hour, using the same oil they should contain;
- carefully clean the shaft and make sure its working surface isn't damaged;
- direct the seal edge to the fluid; in case of hydrodynamic edge, the stripes must be directed so that, considering the shaft rotation direction, the fluid is brought back to the sealing means;
- lay a thin layer of lubricant on the seal edge (oil rather than grease) and fill with grease the gap between seal edge and dust edge in case of double edge seals;
- fit the seal in the relevant housing pressing it or using a drift with flat contact surface; do not beat it with hammer or drift;
- during driving, make sure the seal is perpendicular to its housing and, at the end of the driving, make sure it touches the shoulder;
- to prevent damaging the seal edge against the shaft, lay a suitable protection during installation of both parts.

"O-RINGS"

Lubricate O-rings before fitting them in their seats to prevent any rolling over and twisting, during assembly/installation, thus jeopardizing their sealing action.

SEALANTS

Before laying the sealant on the mating surfaces, prepare them as follows:

- remove possible scales through a metal brush;
- thoroughly degrease the surfaces by one of the following cleansers: trichloroethylene, oil, or a solution of water and soda.

COTTER PINS

While fitting split cotter pins, make sure that their groove is directed towards the effort direction, stressing the pin. Spiral cotter pins do not need any orientation during fitting.

REMARKS ABOUT SPARE PARTS

Use only **genuine parts**.

Only genuine parts guarantee the same quality, life, safety as original parts, as they are the same as those fitted during standard production.

Only **genuine spare parts** can offer this guarantee.

All spare parts orders must be accompanied by the following data:

- machine model (commercial name) and frame number;
- combine type and number;
- part number of the ordered part, which can be found in the "Spare Part Catalogue", used for order processing.

REMARKS ABOUT TOOLS

The tools that AGCO suggests and describes in this manual have been:

- expressly studied and designed to operate on AGCO range combines;
- required to get a reliable repair;
- suitably manufactured and strictly tested to offer efficient and long-lasting working means.

By using these tools, Repair Personnel will benefit from:

- working in the best technical conditions;
- getting the best results;
- saving time and effort;
- working more safely.

CAUTION

Wear limit values indicated for certain parts should be considered to be recommended, but not binding. The words "front", "rear", "right" and "left" referred to different parts are meant with the operator sitting on the driver's seat and directed towards the combine standard running direction.

HOW TO MOVE THE COMBINE WITHOUT BATTERY

The cables of the outer power supply unit must be connected only to the relevant terminals of the negative and positive cables of the combine using efficient pliers to get a suitable and stable contact.

Disconnect all services (lights, windscreen wipers, etc...) before starting the combine.

If the operating efficiency of the combine electrical system must be checked, proceed only after connecting the power supply unit. At the end of the check, disconnect all the services and switch the power supply off before disconnecting its cables.

SAFETY REGULATIONS

PAY ATTENTION TO THIS SYMBOL



This warning symbol points out important messages involving your personal safety. Carefully read all the suggested safety precautions to avoid potential hazards and safeguard your health and personal safety.

In this manual you will find this symbol together with the following key words:

WARNING - In case of warning aimed at preventing unsuitable repair works, involving potential hazards to the operator's safety.

DANGER - Specific warnings concerning potential hazards for operator safety or for other persons directly or indirectly involved.



AVOID ACCIDENTS

Most accidents and injuries occurring in workshops are due to the lacked compliance with some simple and fundamental caution and safety rules. For this reason, **IN MOST CASES THEY CAN BE PREVENTED**: just consider the possible causes in advance and act consequently, with the required caution and care.

Accidents may occur with all types of machine, regardless of how well the machine in question was designed and built.

A cautious and careful mechanic is the best warranty against accidents.

Precise observance of the most basic safety rule is normally sufficient to avoid many serious accidents.

DANGER. Never carry out any cleaning, lubrication or maintenance operation when the engine is running.

SAFETY REGULATIONS

GENERAL FEATURES

- ◇ Strictly comply with the specified maintenance and repair procedures.
- ◇ Never wear rings, watches, jewels, loose or unbuttoned clothing such as ties, torn clothes, scarves, open jackets or shirts with open zips which could get trapped in moving parts. It is recommended to wear clothes approved as for accident prevention, such as anti-skid shoes, gloves, safety goggles, helmets, etc...
- ◇ Never carry out any repair intervention on the machine if someone is sitting on the driver's seat, ex-

cept for authorized operators assisting in the operation to be carried out.

- ◇ Never operate the machine or use attachments from a place other than sitting in the operator's seat.
- ◇ Never carry out any intervention on the machine when the engine is running, except when specifically indicated.
- ◇ Stop the engine and make sure all pressure is relieved from hydraulic circuits before removing caps, covers, valves, etc...
- ◇ All service interventions must be carried out with the utmost care and attention.
- ◇ Service stairs and ladders used in the workshop or in the field should be built in compliance with the safety regulations in force.
- ◇ Disconnect the batteries and label all controls to warn that the machine is being serviced. Lock the machine and all the equipment to be lifted.
- ◇ Never check or fill fuel tanks, accumulator batteries, nor use starting fluid while smoking or next to open flames, as the concerned fluids are flammable.
- ◇ Brakes are ineffective when manually released for service interventions: in such cases, make sure you can keep the machine under continuous control through suitable locks or other.
- ◇ The fuel supply gun must always touch the filler neck. Keep it there until fuel supply stops, to prevent sparks due to static electricity build-up.

- ◇ Use only the prescribed points for towing the machine. Make the connection with the utmost care: make sure that the envisaged pins and/or catches are securely tightened before towing. Never remain near the towing bars, cables or chains that are operating under load.
- ◇ To transfer a faulty machine, use a trailer or low loading platform trailer, when available.
- ◇ To load and unload the machine from the transportation means, select a flat area providing a firm support to the wheels of the trailer or truck. Securely fasten the machine to the platform of the truck or the trailer and lock the wheels as required by the shipping agent.
- ◇ For electrical heaters, battery-chargers and similar equipment, use exclusively auxiliary power supplies providing an efficient ground to avoid electrical shock hazards.
- ◇ While lifting or carrying heavy parts, use hoists and similar equipment, with a suitable capacity.
- ◇ Pay special attention to the presence of bystanders.
- ◇ Never pour gasoline or diesel oil in open, wide and low containers.
- ◇ Never use gasoline, diesel oil or other flammable liquids as cleansers: use non-flammable and non-toxic standard solvents.
- ◇ Wear goggles with side guards while cleaning parts by compressed air.
- ◇ Reduce air pressure according to the local or national regulations in force.
- ◇ Never operate the machine in closed areas, without proper ventilation.
- ◇ Do not smoke, use open flames, nor cause sparks nearby when refilling or handling highly flammable matters.
- ◇ Do not use flames as light sources when servicing the machine or checking for possible "leaks".
- ◇ Move with caution when working under the machine, on the machine itself or nearby. Wear the prescribed safety equipment: helmets, special goggles and shoes.
- ◇ During checks to be made with engine running, ask an operator to sit on the driver's seat and keep the service technician under constant visual control at any time.
- ◇ In case of servicing operations to be made outside the workshop, drive the combine to a flat area and lock it. If the work on hillsides cannot be avoided, first lock the machine and move it to a level ground, as soon as you can do it within a given safety margin.
- ◇ Dented and bent chains or ropes aren't reliable: do not use them for lifting or towing. Always use suitable protective gloves when handling chains or cables.
- ◇ The chains must be tightly fastened: make sure the fastening device is strong enough to hold the envisaged load. No people should stand next to the towing connection, chains or ropes.
- ◇ The area for servicing operations should be kept always CLEAN and DRY. Immediately remove any water deposits or oil stains.
- ◇ Do not pile up oil or grease soaked rags: they are a great fire hazard. Always place them in a closed metal container.
Before starting the machine or the equipment check, adjust and lock the operator's seat. Make sure no person is standing in the machine or equipment operating range.
- ◇ Do not carry in your pockets any object that could accidentally fall in the machine inner compartments.
- ◇ Whenever you might be hit by projecting metal parts and other, wear an eye mask or goggles with side guards, helmets, special footwear and heavy gloves.
- ◇ During welding operations, use the special safety guards: face shield or dark goggles, helmets, overalls, special gloves and footwear. Dark goggles must be worn also by bystanders, if they need to remain next to the operator carrying out welding operations. **NEVER LOOK DIRECTLY AT THE WELDING ARC WITHOUT SUITABLE EYE PROTECTION.**
- ◇ Metal cables, when used, get frayed: always wear suitable protection while handling them (heavy gloves, goggles, etc...).
- ◇ Handle all parts with the utmost care. Keep your hands and fingers away from gaps, gears and others. Always wear the approved protection devices, such as safety goggles, safety gloves and shoes.

START-UP

- ◇ Never run the engine in closed areas without suitable ventilation systems for exhaust gas ejection.
- ◇ Never bring your head, body, arms, legs, feet, hands or fingers next to fans or rotating belts.

ENGINE

- ◇ Before removing the radiator cap loosen it very slowly, to relieve pressure from the system. Coolant top-ups must be made only when the engine is stopped or idle, if hot.
- ◇ Never fill up the fuel tank when the engine is running, especially if it is hot, to prevent triggering fires in case of fuel leaks.
- ◇ Never try to check or adjust the fan belt tension when the engine is running. Never adjust the fuel injection pump when the machine is moving.
- ◇ Never lubricate the machine when the engine is running.

ELECTRICAL SYSTEMS

- ◇ When using auxiliary batteries, remember that the cables on both sides must be connected as follows: (+) with (+) and (-) with (-). Do not short-circuit the terminals. **GAS RELEASED FROM BATTERIES IS HIGHLY FLAMMABLE.** During recharging, leave the battery compartment open for an improved ventilation. Never check the battery charge by "jumpers" obtained by laying metal objects on the terminals. Avoid sparks or flames in the area surrounding the batteries. Do not smoke to prevent explosion hazards.
- ◇ Before any intervention, check there are no fuel or power leaks: eliminate these leaks before going on with the work.
- ◇ Never recharge the batteries in closed areas: make sure there is enough ventilation to prevent accidental explosions due to the build-up of gases released while charging.
- ◇ Always disconnect the batteries before any intervention on the electrical system.

HYDRAULIC SYSTEMS

- ◇ Fluid coming out from a very small port can be almost invisible and be strong enough to penetrate the skin. For this reason, use a piece of cardboard or of wood for checking. **DO NOT USE BARE HANDS:** if the pressurized fluid penetrates under the skin, contact immediately a doctor. As a matter of fact, if no medical care is given, severe infections or dermatosis could occur.
- ◇ While checking the system pressures, use the suitable instruments.

WHEELS AND TYRES

- ◇ Make sure that tyres are correctly inflated at the pressure specified by the manufacturer. Regularly check possible damages of rims and tyres.
- ◇ Keep off and stay next to the tyre to correct the inflating pressure.
- ◇ Check the pressure only with unladen machine and cool tyres to prevent a wrong measurement due to overpressure. Never use parts of recovered wheels as improper welding, brazing or heating could have weakened them and cause breakages.
- ◇ Never cut nor weld a rim with fitted inflated tyre.
- ◇ To remove the wheels, lock both front and rear wheels. After lifting the machine to prevent its falling, arrange suitable supports underneath, according to the regulations in force.
- ◇ Deflate the tyre before removing any object caught in the tread.
- ◇ Never inflate tyres using flammable gases as they may cause explosions and injuries to by-standers.

REMOVAL AND RE-FITTING

- ◇ Lift and handle all heavy parts by suitably sized lifting means. Make sure all the parts are held by suitable slings and hooks. Use the suitable eyebolts. Extra care should be taken if persons are present near the load to be lifted.
- ◇ Handle all parts with great care. Do not put hands and fingers between the pieces. Wear suitable safety clothing - safety goggles, gloves and shoes.
- ◇ Do not twist metal chains or ropes. Always wear safety gloves when handling cables or chains.

COMBINE IDENTIFICATION

The combine and its main parts are identified by serial numbers and/or production codes. The position of the different identification data is shown below.

NOTE: always state the machine identification data to your Dealer while asking for spare parts or service interventions.

Combine identification plate - Figures 1 and 2

The manufacturer data plate (1), envisaged for all countries, (or 2 – for France only), is placed on the right outer side of the operator’s compartment platform and shows the following data:

- combine type.
- Combine frame number.
- Manufacturing year.
- Weights.
- Engine power in kW and rotation speed expressed according to the ISO/TR 14396 standard.
- CE marking.
- Road type-approval number, when required.

Other data are given in the type-approval certificate.

In some countries (e.g. Russia) the manufacturer’s plate is placed next to a decal/label (3) corresponding to the type approval.

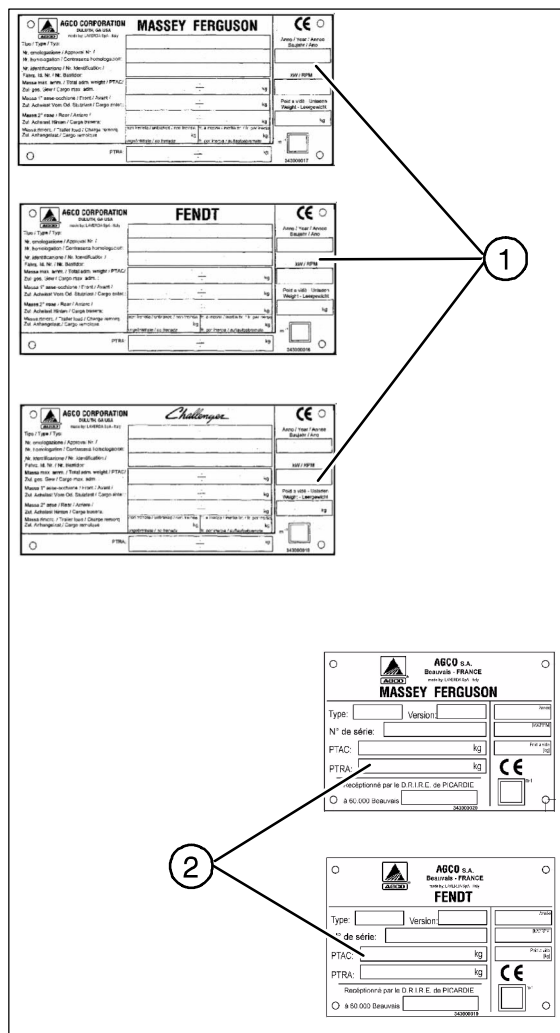

1

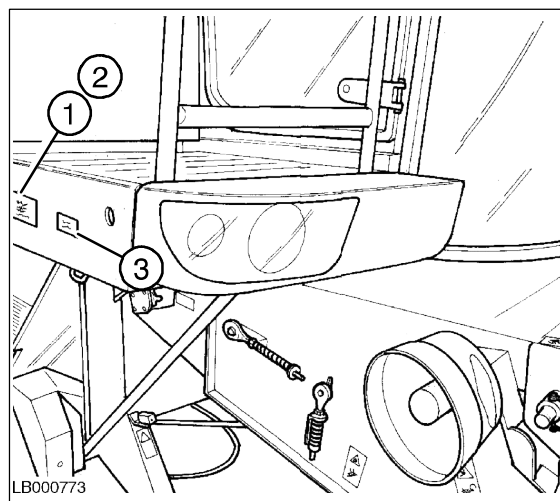

2

Combine identification data - Fig. 3

The combine type and frame number are on the plate and punched also on the frame rear right side (1).

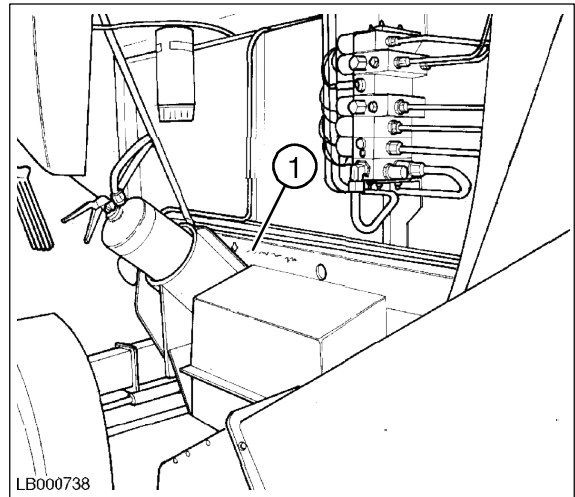

3

**Engine identification -
Figures 4 and 5**

The engine identification is made by the information plate (1), on the valve cover, and the serial number plate (2) on the basement, next to the starter.

The plate (1) shows the following information:

- engine manufacturer;
- engine type
- engine power and rated speed;
- engine serial number;
- valve clearance;
- injection timing (static);
- idling speed;
- 97/68 EC approval engine family code;
- EPA 40 CFR 89 approval family code;
- 97/98/EC approval number;
- name of the engine assembler.

The plate (2) shows the following information:

- engine serial number;
- engine model;
- engine configuration number.

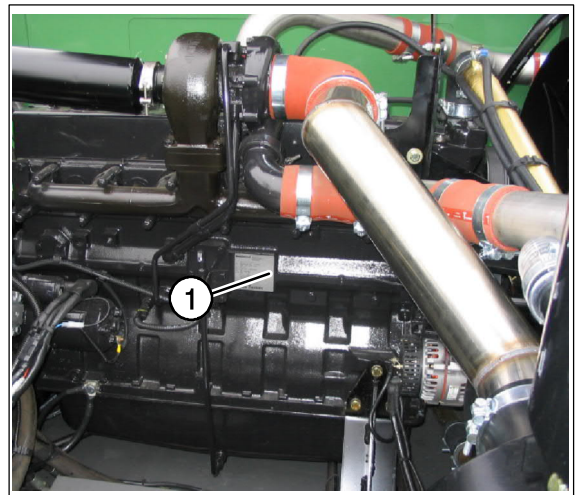

4

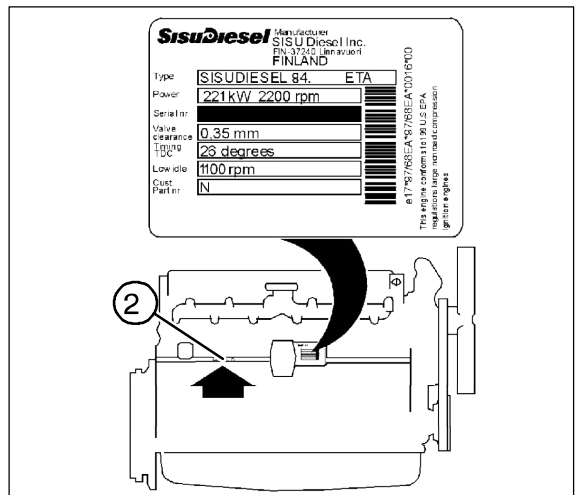

5

SisuDiesel		Manufacturer	
Type	SISUDIESEL 84	ETA	
Power	221kW	2200 rpm	
Serial nr	[Barcode]		
Valve clearance	0.35 mm		
Injection timing	28 degrees		
Low idle	1100 rpm		
Cust. Part nr	N		

6175/765EA/765EA-D076MD
The engine complies with EU ECE
ignition system

**Cutting header identification -
Fig. 6**

The cutting header can be identified thanks to a metal plate located on the left side of the support main beam.

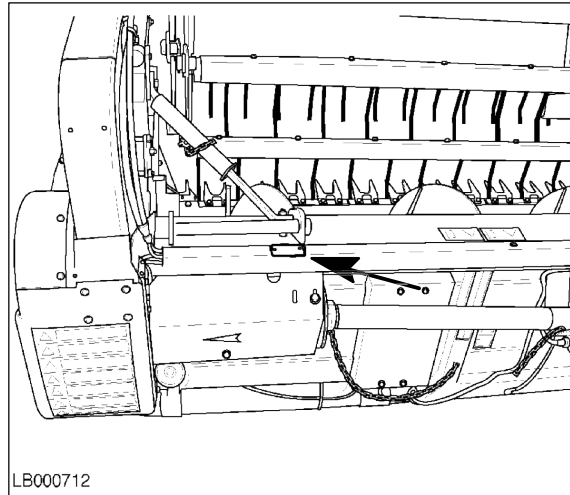

6

**Operator's seat identification -
Fig. 7**

The operator's seat identification plate is located on the seat back part; to reach it, move the seat fully forwards.

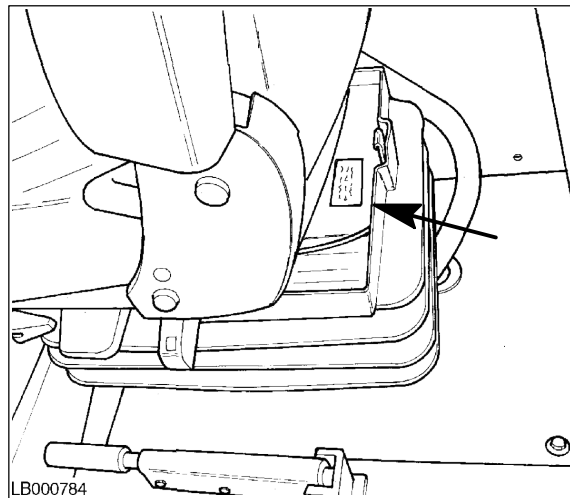

7

**Hydrostatic pump identification -
Fig. 8**

The hydrostatic pump identification is made easier by the presence of a plate located on the pump body front part.

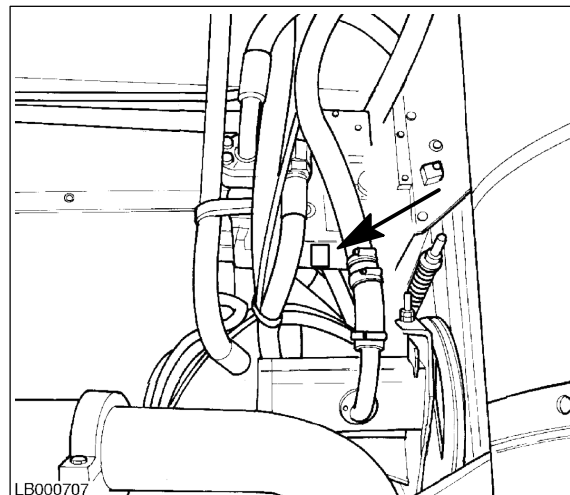

8

**Hydrostatic motor identification -
Fig. 9**

The hydrostatic motor identification is made easier by the presence of a plate located in the engine body lower part.

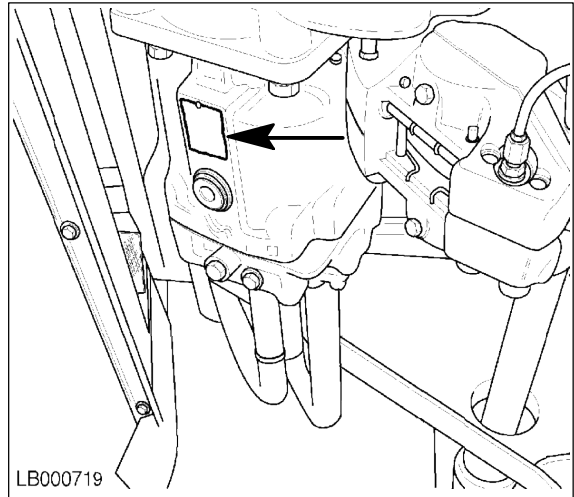

9

**Straw chopper identification (if fitted) -
Fig. 10**

The straw chopper identification plate is located on the right side next to the rotor support.

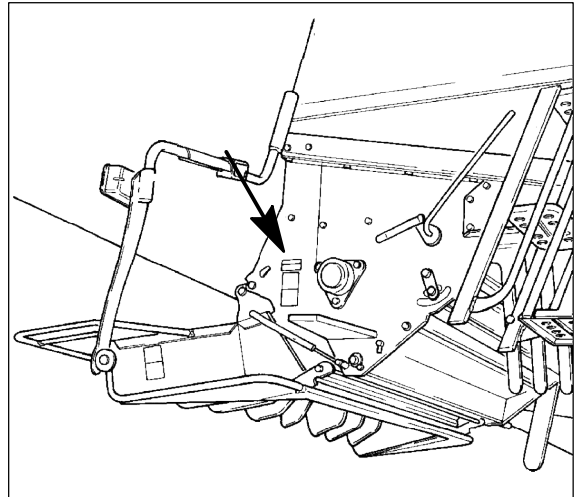

10

**Chaff spreader identification (if fitted) -
Fig. 11**

The identification plate is located on the right side, next to the lever to adjust the chaff spreader position.

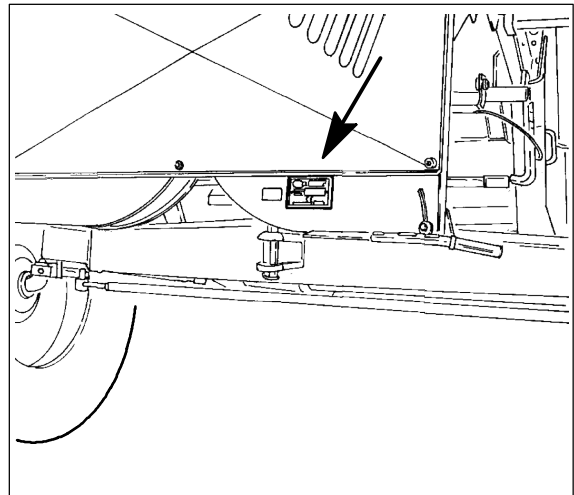

11

Thank you so much for reading.
Please click the “Buy Now!”
button below to download the
complete manual.



After you pay.

You can download the most
perfect and complete manual in
the world immediately.

Our support email:

ebooklibonline@outlook.com