

5255 L

5255 L MCS

6275 L

6275 L MCS

Note: *Some of the models mentioned in this manual may not be marketed in your country.*

For further details, please get in touch with your Dealer

WORKSHOP
MANUAL

FENDT

Your Agriculture Company

CONTENT

	Sections
- GENERAL INFORMATION	00
- ENGINE	10
- LIVE PTO	14
- TRANSMISSION	21
- FRONT MECHANICAL DRIVE	25
- HYDROSTATIC TRANSMISSION	29
- BRAKES	33
- HYDRAULIC SYSTEMS	35
- STEERING	41
- AXLE AND WHEELS	44
- CAB CONDITIONING SYSTEM	50
- ELECTRICAL SYSTEMS	55
- ATTACHMENTS / HEADERS	58
- PRODUCT FEEDING	60
- THRESHING	66
- SEPARATION	72
- STRAW CHOPPER	73
- CLEANING	74
- GRAIN STORAGE	80

FENDT

COMBINES MODELS	MODEL IDENTIFICATION CODE
<i>5255 L</i>	X 5 AS
<i>5255 L MCS</i>	X 5 BS
<i>6275 L</i>	X 6 AS
<i>6275 L MCS</i>	X 6 BS

DESCRIPTION OF THE COMBINE IDENTIFICATION NUMBER

Example.: * $\frac{\text{a}}{5550}$ * $\frac{\text{b}}{555\ 0}$ $\frac{\text{c}}{00001}$ *

d

a Technical type

d Identification number: **55500001**

It is formed by two parts:

- First part (b), formed by 4 numbers "5550", it corresponds to the technical type (machine model).
- Second part (c), formed by 5 numbers "00001" they are the production progressive numbers identifying the progressive number of the produced machine model.

* **5550** * **555 0** * For model **5255 L**

* **5550** * **555 0** * For model **5255 L MCS**

* **5650** * **565 0** * For model **6275 L**

* **5650** * **565 0** * For model **6275 L MCS**

GRAIN HEADER IDENTIFICATION NUMBER (FREE FLOW)

711 6 For model **16 ft (m 4,80)**

711 8 For model **18 ft (m 5,40)**

712 For model **20 ft (m 6,00)**

712 3 For model **23 ft (m 7,00)**

712 5 For model **25 ft (m 7,60)**

Section 00 - GENERAL INFORMATION

GENERAL INSTRUCTION

IMPORTANT NOTE

All maintenance and repair works described in this manual must be carried out only by the AGCO Breganze service network, strictly complying with the instructions given and using the required special tools.

Anybody carrying out the above interventions without strictly complying with the prescriptions is fully responsible for the occurred damage.

ADJUSTMENT SHIMS

During any adjustment, select the adjustment shims measuring them individually, by a micrometer, and then summing up the detected values: do not rely on the wrong measurement of the complete pack or on the rated value stated for each ring.

ROTARY SHAFT SEALS

For correct rotating shaft seal installation, proceed as follows:

- before assembly, leave the seals in oil bath, for at least half an hour, using the same oil they should contain;
- carefully clean the shaft and make sure its working surface isn't damaged;
- direct the seal edge to the fluid; in case of hydrodynamic edge, the stripes must be directed so that, considering the shaft rotation direction, the fluid is brought back to the sealing means;
- lay a thin layer of lubricant on the seal edge (oil rather than grease) and fill with grease the gap between seal edge and dust edge in case of double edge seals;
- fit the seal in the relevant housing pressing it or using a drift with flat contact surface; do not beat it with hammer or drift;
- during driving, make sure the seal is perpendicular to its housing and, at the end of the driving, make sure it touches the shoulder;
- to prevent damaging the seal edge against the shaft, lay a suitable protection during installation of both parts.

“O-RINGS”

Lubricate O-rings before fitting them in their seats to prevent any rolling over and twisting, during assembly/installation, thus jeopardizing their sealing action.

SEALANTS

Before laying the sealant on the mating surfaces, prepare them as follows:

- remove possible scales through a metal brush;
- thoroughly degrease the surfaces by one of the following cleansers: trichloroethylene, oil, or a solution of water and soda.

COTTER PINS

While fitting split cotter pins, make sure that their groove is directed towards the effort direction, stressing the pin. Spiral cotter pins do not need any orientation during fitting.

REMARKS ABOUT SPARE PARTS**Use only AGCO genuine parts**

Only genuine parts guarantee the same quality, life, safety as original parts, as they are the same as those fitted during standard production.

Only **AGCO genuine spare** parts can offer this guarantee.

All spare parts orders must be accompanied by the following data:

- machine model (commercial name) and frame number;
- combine type and number;
- part number of the ordered part, which can be found in the "Spare Part Catalogue", used for order processing.

REMARKS ABOUT TOOLS

The tools that AGCO suggests and describes in this manual have been:

- expressly studied and designed to operate on AGCO range combines;
- required to get a reliable repair;
- suitably manufactured and strictly tested to offer efficient and long-lasting working means.

By using these tools, Repair Personnel will benefit from:

- working in the best technical conditions;
- getting the best results;
- saving time and effort;
- working more safely.

CAUTION

Wear limit values indicated for certain parts should be considered to be recommended, but not binding. The words "front", "rear", "right" and "left" referred to different parts are meant with the operator sitting on the driver's seat and directed towards the combine standard running direction.

HOW TO MOVE THE COMBINE WITHOUT BATTERY

The cables of the outer power supply unit must be connected only to the relevant terminals of the negative and positive cables of the combine using efficient pliers to get a suitable and stable contact.

Disconnect all services (lights, windscreen wipers, etc...) before starting the combine.

If the operating efficiency of the combine electrical system must be checked, proceed only after connecting the power supply unit. At the end of the check, disconnect all the services and switch the power supply off before disconnecting its cables.

SAFETY REGULATIONS

PAY ATTENTION TO THIS SYMBOL



This warning symbol points out important messages involving your personal safety. Carefully read all the suggested safety precautions to avoid potential hazards and safeguard your health and personal safety.

In this manual you will find this symbol together with the following key words:

WARNING - *In case of warning aimed at preventing unsuitable repair works, involving potential hazards to the operator's safety.*

DANGER - *Specific warnings concerning potential hazards for operator safety or for other persons directly or indirectly involved.*



AVOID ACCIDENTS

Most accidents and injuries occurring in workshops are due to the lacked compliance with some simple and fundamental caution and safety rules. For this reason, **IN MOST CASES THEY CAN BE PREVENTED**: just consider the possible causes in advance and act consequently, with the required caution and care.

Accidents may occur with all types of machine, regardless of how well the machine in question was designed and built.

A cautious and careful mechanic is the best warranty against accidents.

Precise observance of the most basic safety rule is normally sufficient to avoid many serious accidents.

DANGER. Never carry out any cleaning, lubrication or maintenance operation when the engine is running.

SAFETY REGULATIONS

GENERAL FEATURES

- ◇ Strictly comply with the specified maintenance and repair procedures.
- ◇ Never wear rings, watches, jewels, loose or unbuttoned clothing such as ties, torn clothes, scarves, open jackets or shirts with open zips which could get trapped in moving parts. It is recommended to wear clothes approved as for accident prevention, such as anti-skid shoes, gloves, safety goggles, helmets, etc...
- ◇ Never carry out any repair intervention on the machine if someone is sitting on the driver's

seat, except for authorized operators assisting in the operation to be carried out.

- ◇ Never operate the machine or use attachments from a place other than sitting in the operator's seat.
- ◇ Never carry out any intervention on the machine when the engine is running, except when specifically indicated.
- ◇ Stop the engine and make sure all pressure is relieved from hydraulic circuits before removing caps, covers, valves, etc...
- ◇ All service interventions must be carried out with the utmost care and attention.
- ◇ Service stairs and ladders used in the workshop or in the field should be built in compliance with the safety regulations in force.
- ◇ Disconnect the batteries and label all controls to warn that the machine is being serviced. Lock the machine and all the equipment to be lifted.
- ◇ Never check or fill fuel tanks, accumulator batteries, nor use starting fluid while smoking or next to open flames, as the concerned fluids are flammable.
- ◇ Brakes are ineffective when manually released for service interventions: in such cases, make sure you can keep the machine under continuous control through suitable locks or other.
- ◇ The fuel supply gun must always touch the filler neck. Keep it there until fuel supply stops, to prevent sparks due to static electricity build-up.

- ◇ Use only the prescribed points for towing the machine. Make the connection with the utmost care: make sure that the envisaged pins and/or catches are securely tightened before towing. Never remain near the towing bars, cables or chains that are operating under load.
- ◇ To transfer a faulty machine, use a trailer or low loading platform trailer, when available.
- ◇ To load and unload the machine from the transportation means, select a flat area providing a firm support to the wheels of the trailer or truck. Securely fasten the machine to the platform of the truck or the trailer and lock the wheels as required by the shipping agent.
- ◇ For electrical heaters, battery-chargers and similar equipment, use exclusively auxiliary power supplies providing an efficient ground to avoid electrical shock hazards.
- ◇ While lifting or carrying heavy parts, use hoists and similar equipment, with a suitable capacity.
- ◇ Pay special attention to the presence of by-standers.
- ◇ Never pour gasoline or diesel oil in open, wide and low containers.
- ◇ Never use gasoline, diesel oil or other flammable liquids as cleansers: use non-flammable and non-toxic standard solvents.
- ◇ Wear goggles with side guards while cleaning parts by compressed air.
- ◇ Reduce air pressure according to the local or national regulations in force.
- ◇ Never operate the machine in closed areas, without proper ventilation.
- ◇ Do not smoke, use open flames, nor cause sparks nearby when refilling or handling highly flammable matters.
- ◇ Do not use flames as light sources when servicing the machine or checking for possible "leaks".
- ◇ Move with caution when working under the machine, on the machine itself or nearby. Wear the prescribed safety equipment: helmets, special goggles and shoes.
- ◇ During checks to be made with engine running, ask an operator to sit on the driver's seat and keep the service technician under constant visual control at any time.
- ◇ In case of servicing operations to be made outside the workshop, drive the combine to a flat area and lock it. If the work on hillsides cannot be avoided, first lock the machine and move it to a level ground, as soon as you can do it within a given safety margin.
- ◇ Dented and bent chains or ropes aren't reliable: do not use them for lifting or towing. Always use suitable protective gloves when handling chains or cables.
- ◇ The chains must be tightly fastened: make sure the fastening device is strong enough to hold the envisaged load. No people should stand next to the towing connection, chains or ropes.
- ◇ The area for servicing operations should be kept always CLEAN and DRY. Immediately remove any water deposits or oil stains.
- ◇ Do not pile up oil or grease soaked rags: they are a great fire hazard. Always place them in a closed metal container. Before starting the machine or the equipment check, adjust and lock the operator's seat. Make sure no person is standing in the machine or equipment operating range.
- ◇ Do not carry in your pockets any object that could accidentally fall in the machine inner compartments.
- ◇ Whenever you might be hit by projecting metal parts and other, wear an eye mask or goggles with side guards, helmets, special footwear and heavy gloves.
- ◇ During welding operations, use the special safetyguards: face shield or dark goggles, helmets, overalls, special gloves and footwear. Dark goggles must be worn also by bystanders, if they need to remain next to the operator carrying out welding operations. NEVER LOOK DIRECTLY AT THE WELDING ARC WITHOUT SUITABLE EYE PROTECTION.
- ◇ Metal cables, when used, get frayed: always wear suitable protection while handling them (heavy gloves, goggles, etc...).
- ◇ Handle all parts with the utmost care. Keep your hands and fingers away from gaps, gears and others. Always wear the approved protection devices, such as safety goggles, safety gloves and shoes.

START-UP

- ◇ Never run the engine in closed areas without suitable ventilation systems for exhaust gas ejection.
- ◇ Never bring your head, body, arms, legs, feet, hands or fingers next to fans or rotating belts.

ENGINE

- ◇ Before removing the radiator cap loosen it very slowly, to relieve pressure from the system. Coolant top-ups must be made only when the engine is stopped or idle, if hot.
- ◇ Never fill up the fuel tank when the engine is running, especially if it is hot, to prevent triggering fires in case of fuel leaks.
- ◇ Never try to check or adjust the fan belt tension when the engine is running. Never adjust the fuel injection pump when the machine is moving.
- ◇ Never lubricate the machine when the engine is running.

ELECTRICAL SYSTEMS

- ◇ When using auxiliary batteries, remember that the cables on both sides must be connected as follows: (+) with (+) and (-) with (-). Do not short-circuit the terminals. **GAS RELEASED FROM BATTERIES IS HIGHLY FLAMMABLE.** During recharging, leave the battery compartment open for an improved ventilation. Never check the battery charge by "jumpers" obtained by laying metal objects on the terminals. Avoid sparks or flames in the area surrounding the batteries. Do not smoke to prevent explosion hazards.
- ◇ Before any intervention, check there are no fuel or power leaks: eliminate these leaks before going on with the work.
- ◇ Never recharge the batteries in closed areas: make sure there is enough ventilation to prevent accidental explosions due to the build-up of gases released while charging.
- ◇ Always disconnect the batteries before any intervention on the electrical system.

HYDRAULIC SYSTEMS

- ◇ Fluid coming out from a very small port can be almost invisible and be strong enough to penetrate the skin. For this reason, use a piece of cardboard or of wood for checking. **DO NOT USE BARE HANDS:** if the pressurized fluid penetrates under the skin, contact immediately a doctor. As a matter of fact, if no medical care is given, severe infections or dermatosis could occur.
- ◇ While checking the system pressures, use the suitable instruments.

WHEELS AND TYRES

- ◇ Make sure that tyres are correctly inflated at the pressure specified by the manufacturer. Regularly check possible damages of rims and tyres.
- ◇ Keep off and stay next to the tyre to correct the inflating pressure.
- ◇ Check the pressure only with unladen machine and cool tyres to prevent a wrong measurement due to overpressure. Never use parts of recovered wheels as improper welding, brazing or heating could have weakened them and cause breakages.
- ◇ Never cut nor weld a rim with fitted inflated tyre.
- ◇ To remove the wheels, lock both front and rear wheels. After lifting the machine to prevent its falling, arrange suitable supports underneath, according to the regulations in force.
- ◇ Deflate the tyre before removing any object caught in the tread.
- ◇ Never inflate tyres using flammable gases as they may cause explosions and injuries to by-standers.

REMOVAL AND RE-FITTING

- ◇ Lift and handle all heavy parts by suitably sized lifting means. Make sure all the parts are held by suitable slings and hooks. Use the suitable eyebolts. Extra care should be taken if persons are present near the load to be lifted.
- ◇ Handle all parts with great care. Do not put hands and fingers between the pieces. Wear suitable safety clothing - safety goggles, gloves and shoes.
- ◇ Do not twist metal chains or ropes. Always wear safety gloves when handling cables or chains.

PROPER USE

X5AS, X5BS, X6AS and X6BS series of combines are designed as self-propelled units, with a diesel engine.

These machines are intended for standard agricultural applications, to process cereals, small seeds, rice, maize, soya, etc..., by cutting or picking-up from the swath, threshing, separating grains from ears and storing them in the suitable tank until discharging them into transportation means.

When operating the machine, make sure the cab doors are shut. The operator and eventually the instructor must remain seated with their seatbelt fastened (the operator should not drive the machine when standing).

The machine must be used only by a skilled operator, fully acquainted with all the harvesting controls and techniques.

Machine stability is ensured on the following inclinations, on condition that the ground is firm and the tyres offer sufficient grip:

- 30% (18 °) longitudinal and crosswise.



WARNING: when the crop is inside the crop tank, no transfer is allowed on public roads.

HEADER TYPES

X5AS, X5BS, X6AS and X6BS series of combines are equipped with 4,80 - 5,40 - 6,00 - 7,00 or 7,60 m cutting header.

NOTE: in this manual, the term "header/s" is used to identify both the cutting header and the maize header. The term "cutting header" refers to the equipment formed by reel, cutting blade, auger, etc... used to harvest corn, barley, rice, soya, etc... The term "maize header" refers to the equipment formed by stalk grippers, stripping blades, conveyor chains, etc... used for maize harvesting.

GENERAL FEATURES

	X5AS	X5BS	X6AS	X6BS
FEEDING DEVICE				
CUTTING HEADER	Grain header			
- min. and max cutting height. mm	50 ÷ 1320			
- cutting width	16 ft (m 4,80), 18 ft (m 5,40), 20ft (m 6,00), 23 ft (m 7,00), 25 ft (m 7,60)			
- cutting frequency	1244			
- GSAX device	standard			
- AUGER	double-screw type with toothed torque limiter			
- articulated fingers	on the whole width of the auger and fitted on self-lubricating bushes			
- articulated fingers diameter mm	16			
- REEL	with six bars and closed spiders			
- transmission	Hydraulic			
- vertical and horizontal positioning	ElectroHydraulically operated			
- speed variator	Hydraulically operated (from 0 to 55 rpm)			
ELEVATOR	multi-purpose type			
- lower roller	floating			
- PFR feed roller with parallel fingers and toothed safety clutch	NO	YES	NO	YES
- Feed roller fingers diameter mm	16			
- Chains with slats	3		4	
- Slats	36	30	36	30
- Protection	Spring-loaded safety clutch			
- Top shaft speed	425			
- Front shaft speed	622	622		
- Elevator drive belt	by multiple V-type belt			
THRESHING UNIT				
- Stone trap	At concave inlet. To be opened with outside lever, cut-out possibility			
BEATER type Cereal/maize	with 8 beating bars and 8 ballast bars			
- housing width mm	1346		1600	
- beater width mm	1331		1585	
- diameter mm	600			
- variator	with one belt		with two belts	
- Variator control	Electrohydraulic			
- rotation speed rpm	380 ÷ 1100		430 ÷ 1210	

	X5AS	X5BS	X6AS	X6BS
CONCAVE	independent front and rear opening, adjustable from the driver's seat			
- control				
- surface m ²	0,83		0,99	
Cereal type:				
- Clearance (between wire centres) mm	14,1			
- Wire arrangement	Alternately 403 and 630			
- Wrap	106°			
- Wire diameter mm	3,5			
- Total number of wires	93		111	
- spranghe	12			
Tipo per mais:				
- spaziatura (tra centro e centro di ogni filo) . mm	24			
- angolo di avvolgimento	106°			
- diametro fili mm	6			
- bars	9			
Maize type				
- Bars	6			
- Rod diameter mm	14			
- Wrap	102°			
Universal type:				
- Bars	17			
- Wire diameter mm	6			
- Wrap	102°			
CONCAVE EXTENSION (rake)				
- Bars	2			
- Wrap	14°			
REAR BEATER				
- Vanes	4 vanes, removable from inside the tank			
- control	by multiple V-type belt (4HB)			
- rotation speed (empty/loaded) rpm	800			
REAR BEATER CONCAVE				
- Concave wrap	2°			
- Concave area m ²	0,44		0,53	
- Bars	6			
- Clearance	104			
- Wire diameter mm	6			
- Concave to rear beater clearance mm	25			

	X5AS	X5BS	X6AS	X6BS
MULTI CROP SEPARATOR				
Electrically-adjustable concave position	NO	YES	NO	YES
- Spikes	-	70	-	80
- diameter	-	600	-	600
- width	-	1310	-	1565
- standard rotation speed	-	750	-	750
- reduced rotation speed	-	410	-	410
- control	V-belt			
MULTI-CROP-SEPARATOR CONCAVE	NO	YES	NO	YES
- Bars	-	8	-	8
- Wire diameter	-	6	-	6
- Wrap	-	57°	-	57°
- Area	-	0,46	-	0,54
- Clearance	-	52	-	52
- MCS to concave clearance	-	25 ÷ 40	-	25 ÷ 40
STRAW WALKER	5		6	
- Gratings and levels	5 and 4			
- Length	4256			
- Separating surface	5,73		6,81	
- Rotation speed	177			
CLEANING EQUIPMENT				
FAN	with adjustable air flow			
- Rotation speed	350 ÷ 1050			
- Reduced rotation speed	270 ÷ 840			
- Number of vanes	4			
- Control	V-Belt			
MAIN GRAIN PAN	Fixed, with front access for maintenance			
- Movement	alternating, opposite to bottom sieve			
- Con rod	285			
- Control	Double V-Belts			
- Grain pan width	1340		1600	
- Grain pan length	1723			
- Grain pan area	2,31		2,76	
- Grain pan rake area	0,255		0,304	
TOP SIEVE	with adjustable sieve			
- Top sieve width	1340		1600	
- Top sieve length	1963			
- Top sieve area	2,63		3,14	

	X5AS	X5BS	X6AS	X6BS
BOTTOM SIEVE	with adjustable sieve			
- Bottom sieve length mm	1340		1600	
- Bottom sieve width mm	1525			
- Bottom sieve area m ²	2,04		2,44	
RETURNS	to the beater			
- Conveyed by	Returns auger and elevator			
- Returns auger speed rpm	315			
CROP TANK				
- Crop conveyed by	Tank filling elevator and tank filling auger into the middle of the grain tank			
- Tank filling elevator speed rpm	388			
- capacity litri	8600			
- crop discharge engagement	Powerband belt, chain and angle gear			
- Overload protection	Shear bolt			
- Length of unloading tube m	4,50			
- Unloading speed litres/sec	85			
- Unloading height mm	4200			
HYDRAULIC SYSTEM				
- Oil reservoir capacity litres	36			
- Table hydraulics pump oil flow .. litres/min	37,5			
- Table control valve max. pressure bar	200			
- Service pump capacity litres/min	4			
- Control valve max. pressure bar	85			
- Power steering pump capacity .. litres/min	15,5			
- Power steering pump displacement cm ³ /rev	125			
- Max. Pressure bar	140			
- Anti-shock valve max. pressure bar	200			
- Return filter micron	16			

	X5AS	X5BS	X6AS	X6BS
HYDROSTATIC TRANSMISSION				
- Oil tank capacity litri	36			
- pump capacity cm ³ /rev	100			
- pump rpm	2450			
- pressure relief valve setting bar	420			
- motor capacity cm ³ /rev	100			
- Return filter micron	16			
- Pressure filter micron	10			
ENGINE				
- Make	AGCO SISU POWER			
- Type	6.6 AWI. 746	6.6 AWI. 746	7.4 AWI. 747	7.4 AWI. 747
- Cylinder n	6			
- Displacement cm ³	6600		7400	
- Bore mm	108		108	
- Stroke mm	120		134	
- Combustion	Direct injection			
- Rotation direction (from the flywheel)	Anti-clockwise			
- Nominal speed rpm	2200			
- Maximum power (ECE 120 R) kW	179		203	
- Engine sump capacity without filters . litres	29,5			
- Engine sump capacity with filters litres	32			
- Fuel tank litres	620			
- AdBlue tank capacity litres	80			
- Radiator, system capacity litres	56			
ELECTRICAL COMPONENTS				
BATTERY	12 V			
- Type (20h) A/h	200			
- Peak current A	1200			
STARTER MOTOR	12 V			
ALTERNATOR	14 V			
- Charging capacity A	150			

	X5AS	X5BS	X6AS	X6BS
TRANSMISSION				
GEARBOX	with front engagements			
- gear range	4			
WEIGHT				
- Combine (2WD) weight without table, with straw chopper and empty grain tank	12600	12800	13000	13200
- Front weight	7900	8100	8200	8400
- Rear weight	4700	4700	4800	4800
- Combine (4WD) weight without table, with straw chopper and empty grain tank	12880	13080	13280	13480
- Front weight	7900	8100	8200	8400
- Rear weight	4980	4980	5080	5080
MAXIMUM WEIGHTS TECHNICALLY ACCEPTABLE ON PUBLIC ROADS				
<i>Note: The following weights refer to Italian approval and are displayed on the respective approvals tag; for all other countries, please check the maximum weights displayed in the vehicle registration documents.</i>				
- total weight	16700			
- front weight	13300			
- rear weight	5600			

CAPACITIES AND SPECIFICATIONS

PARTS TO BE FILLED	QUANTITY dm ³ (litres)		INTERNATIONAL SPECIFICATION
	X5AS X5BS	X6AS X6BS	
Engine cooling system	56		CUNA 956-16
Fuel tank	620		EN 590
AdBlue tank	80		DIN 70070 ISO 22241
Engine sump and filter	29,5 e 2,5		API CJ4 ACEA E9 SAE 15W40
Compressor (maintenance)	0,25		
Brake tank and circuit	0,30		NHTSA 116 DOT 4 SAE J 1704
Transmission and differential housing	12		API GL5 SAE 80W-90
Final drives	23x2		
Tank discharge lower bevel gear pair	0,50		
Hydrostatic transmission and Hydraulic tank	36 (65,5)	36 (65,5)	DIN 51524 Part 2 HV 46 ISO VG 46 HV
Tank elevator bevel gear pair	0,22		NLGI 2
Tank discharge upper bevel gear pair	0,15		
Chaff spreader bevel gear pair	0,35		
Compressor (automatic) - DELPHI V5-VDA	0,26 (210 grams)		-
A/C system	2500 grams		-
Grease fittings	-		NLGI 2
Oilers	-		Biodegradable ISO VG 46
Windscreen washer	1,50		CUNA 956-11

DIMENSIONS

The figures shown below refer to combines series X5AS, X5BS, X6AS ed X6BS with side ladder access to the cab and a completely enclosed unloading auger.

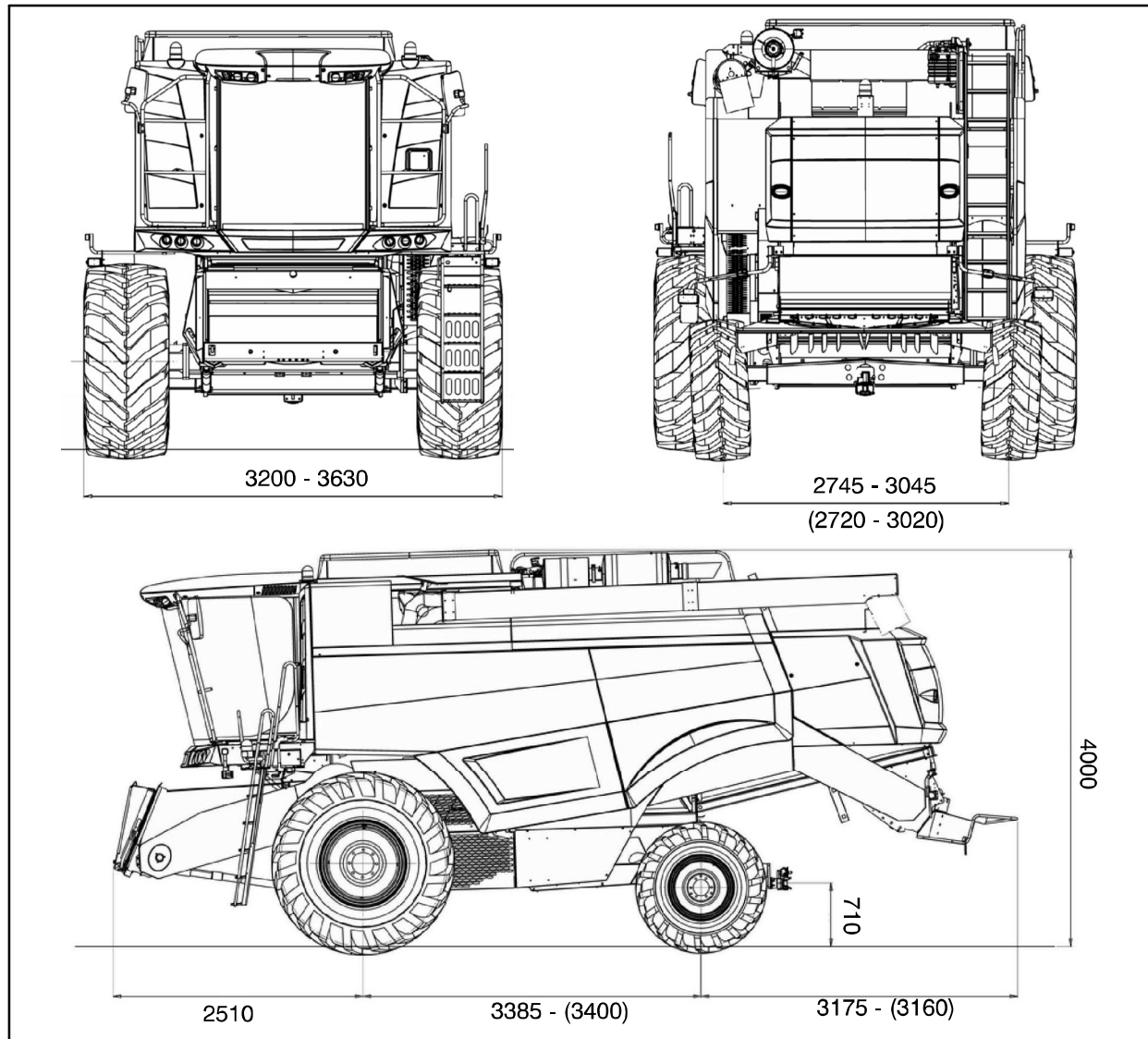
X5AS, X5BS

(Dimension referred to 4WD models)

X6AS, X6BS

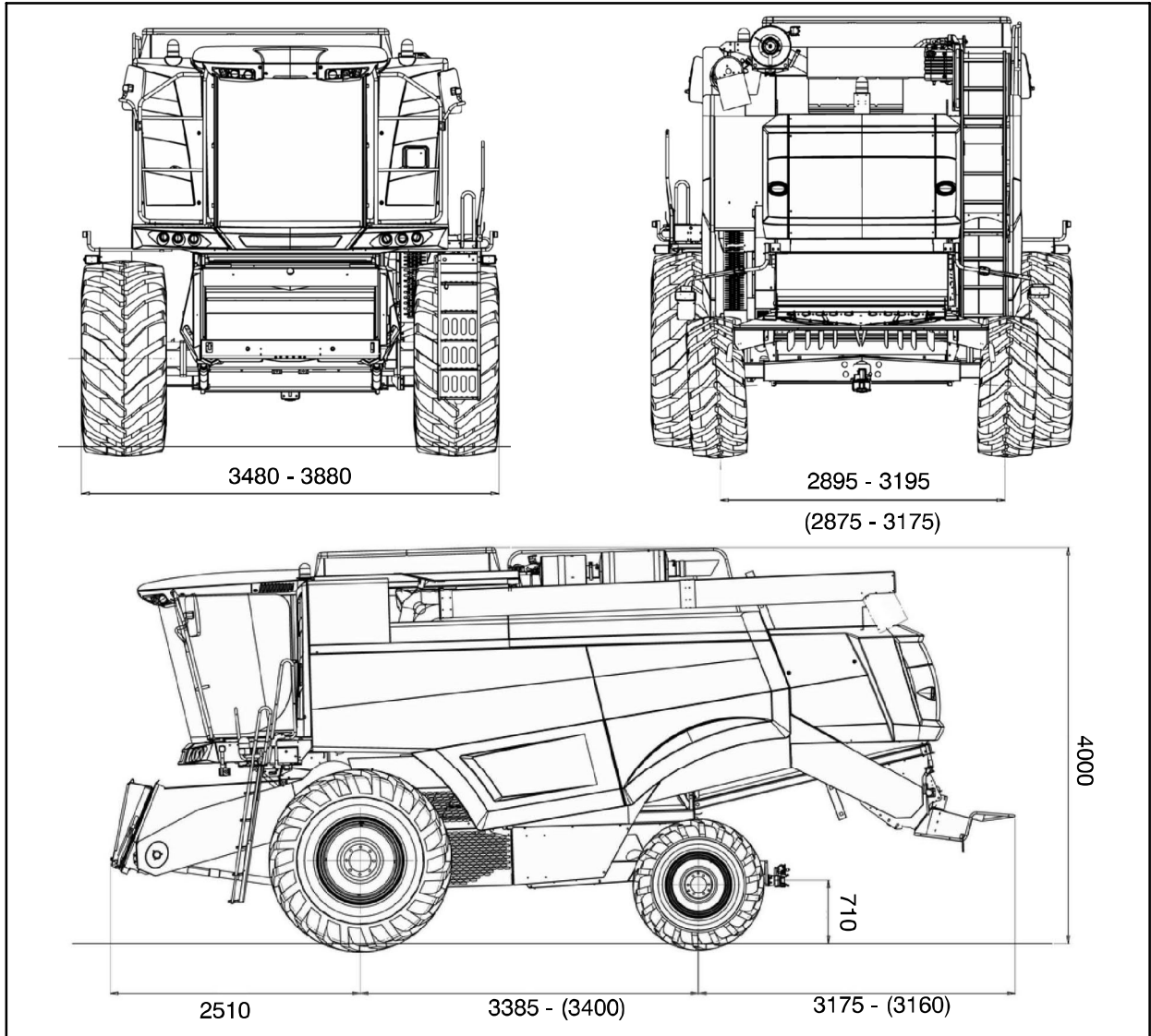

(Dimension referred to 4WD models)

Thank you so much for reading.
Please click the “Buy Now!”
button below to download the
complete manual.



After you pay.

You can download the most
perfect and complete manual in
the world immediately.

Our support email:

ebooklibonline@outlook.com