

Massey Ferguson®

8831 Planter

WORKSHOP SERVICE MANUAL 4283396M1

CONTENTS

GENERAL INFORMATION	01
ROW UNIT	02
DRIVE TRANSMISSION.....	03
AIR SYSTEM	04
HYDRAULICS	05
ELECTRICAL	06
FRAME	07
TROUBLESHOOTING	08
CONSOLES AND MONITORS.....	09

HYDRAULIC DRIVE

GENERAL INFORMATION

Operation

FIG. 2: The drive motor turns the drive group assembly, which turns the drive shaft. The motor is located in the rear of the planter towards the center.

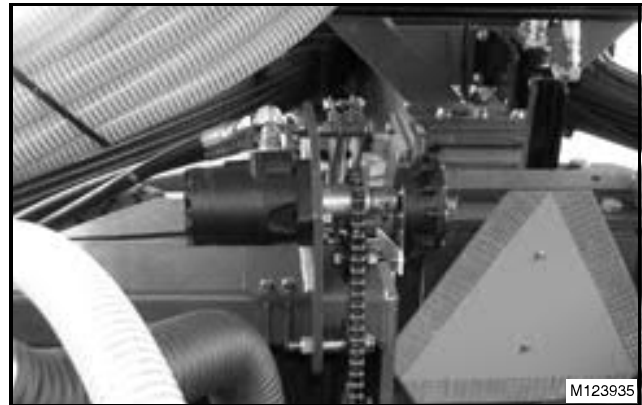

FIG. 2

ROLLER CHAIN

Removal

FIG. 3: Push down on the idler pulley (1) to reduce chain tension and remove the 82 link roller chain (2).

The roller chain has a spring clip connector to easily separate.

Inspect roller chain. Replace roller chain as required.

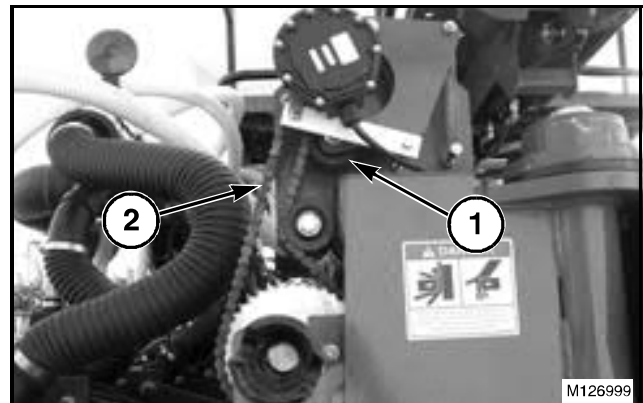

FIG. 3

Installation

Place the roller chain correctly on sprockets.

Push down idler pulley and install the roller chain.

Release the idler pulley to increase the roller chain tension.

Hydraulic Drive

16 TOOTH SPROCKET

Removal

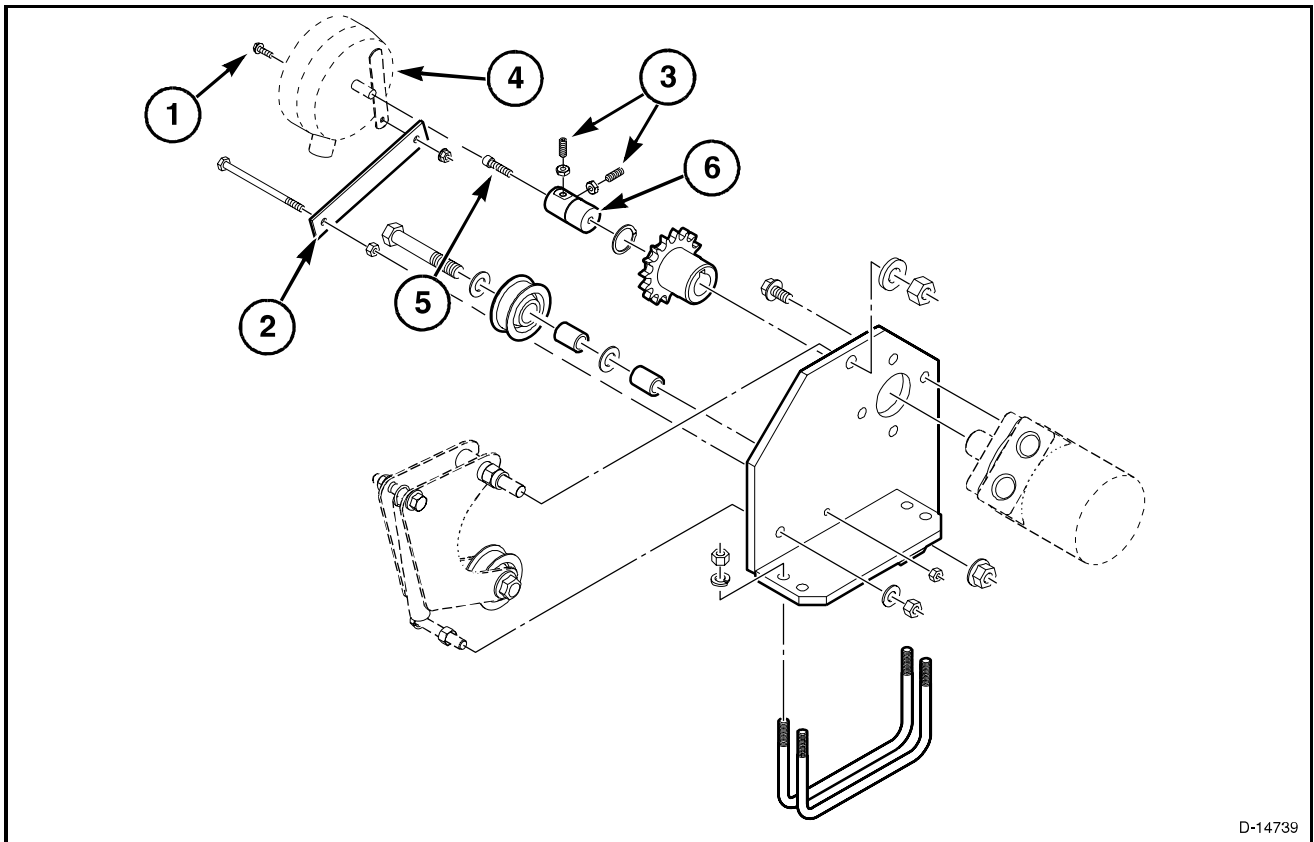

D-14739

FIG. 4

FIG. 4: Remove roller chain.

Remove nut and bolt (1) from strap (2).

Loosen the two set screws (3).

Slide speed sensor (4) off.

Remove hex-head screw (5) from motor shaft.

Slide sleeve off (6).

FIG. 5: Slide the 16 tooth sprocket (1) off motor shaft.

Clean or replace sprocket as needed.

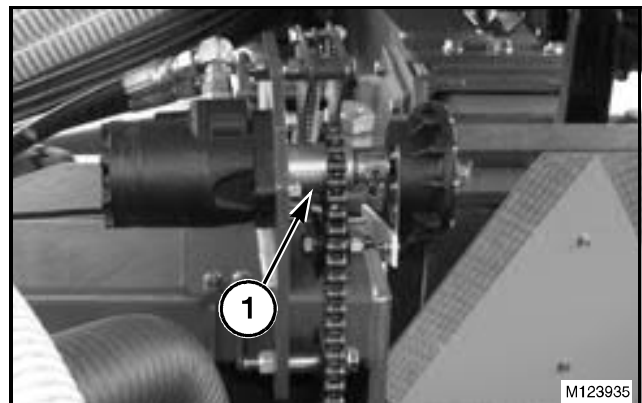
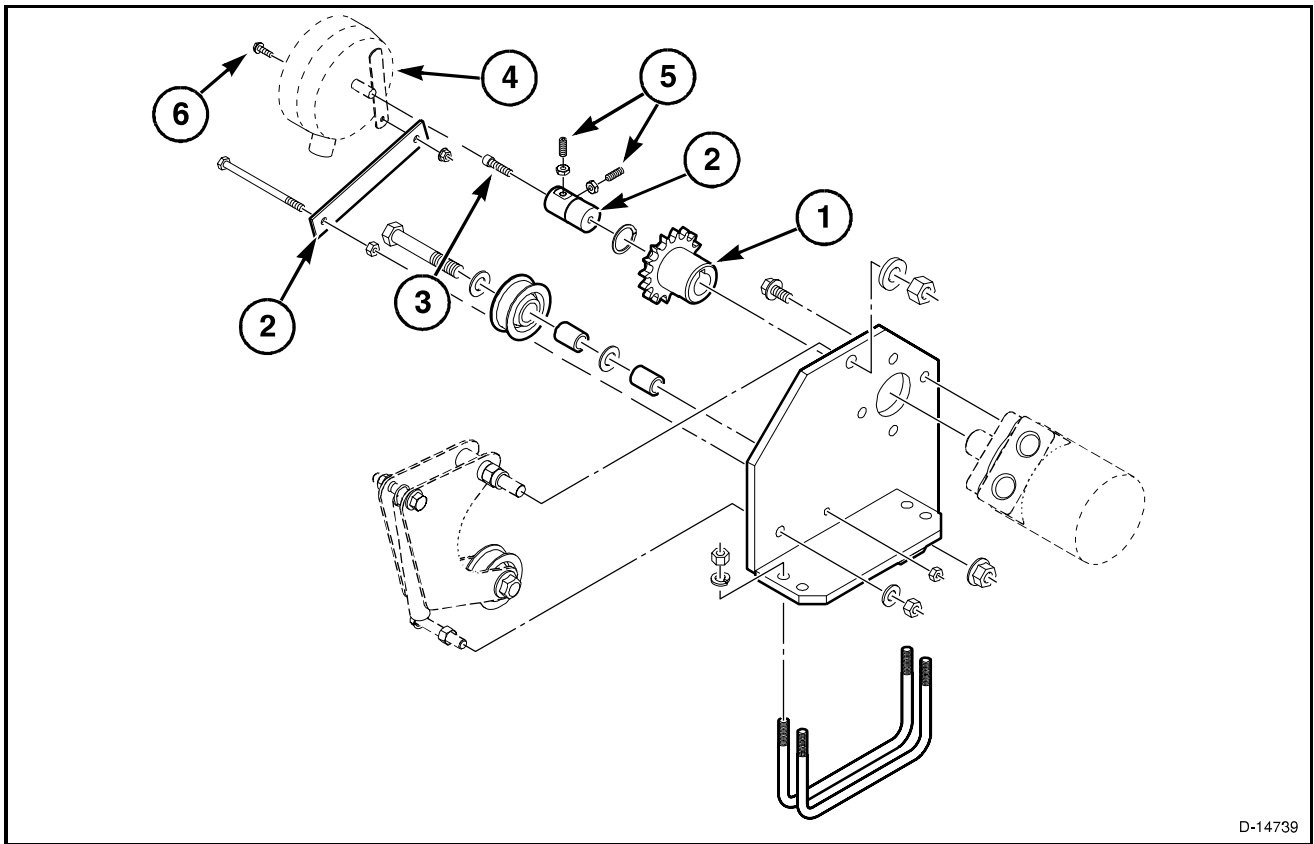

FIG. 5

Installation



D-14739

FIG. 6

FIG. 6: Make sure groove in sprocket aligns with key in motor shaft.

Slide sprocket (1) onto shaft.

Reduce pulley tension and install chain on sprocket.

Install sleeve (2).

Install hex-head screw (3) to motor shaft.

Make sure sprocket is aligned with the idler pulleys and the sprocket on the lower drive shaft.

Install speed sensor (4).

Tighten set screws (5) on sleeve.

Attach strap with nut and bolt (6).

Hydraulic Drive

IDLER PULLEY ASSEMBLY

Removal

FIG. 7: Remove roller chain.

Remove nuts and washers on the bracket side of the cap screws (1).

Remove the idler pulley assembly (2).

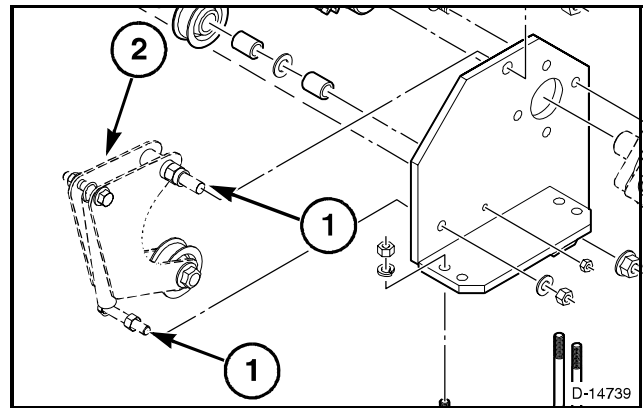

FIG. 7

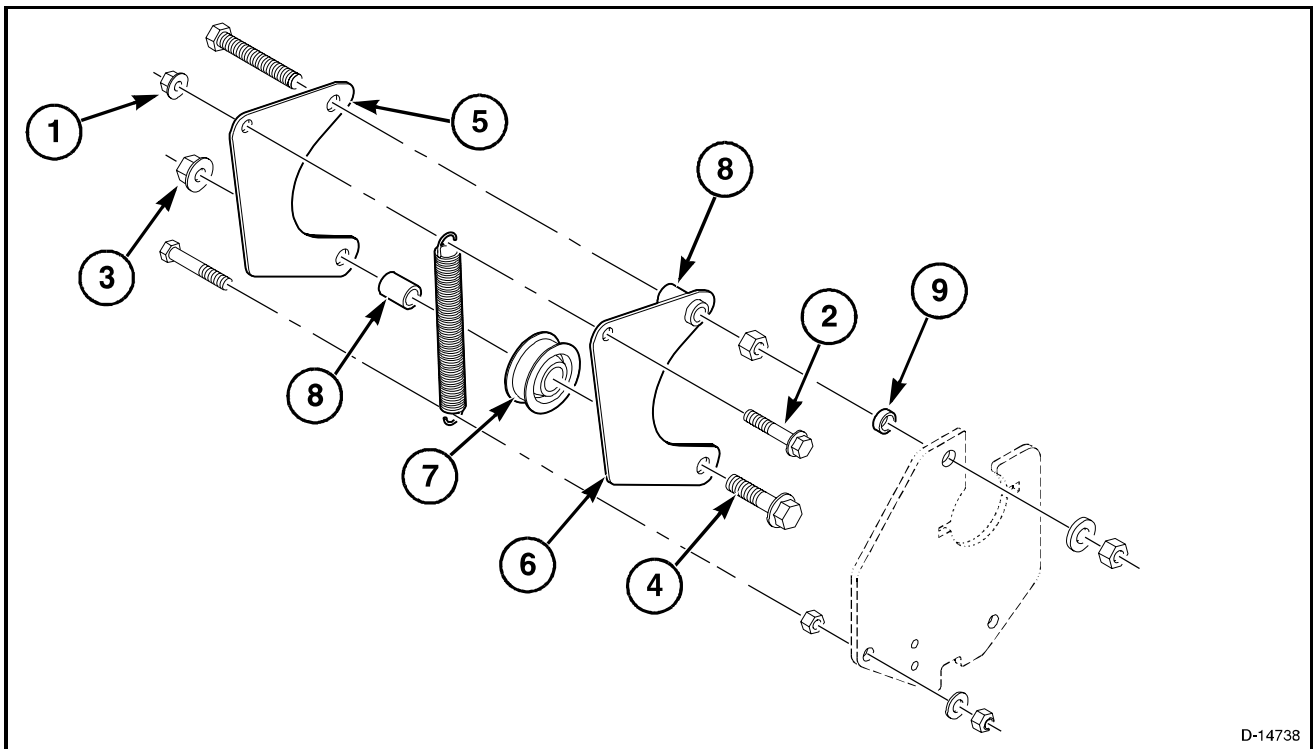

FIG. 8

FIG. 8: Remove flange top lock nut (1) and flange screw (2).

Remove flange top lock nut (3) and flange screw (4).

Separate arm tightener (5) from chain tightener (6).

Remove idler pulley (7) and spacers (8).

Set spacer (9) aside with rest of hardware when removing the idler pulley assembly.

Replace idler pulley if needed.

Installation

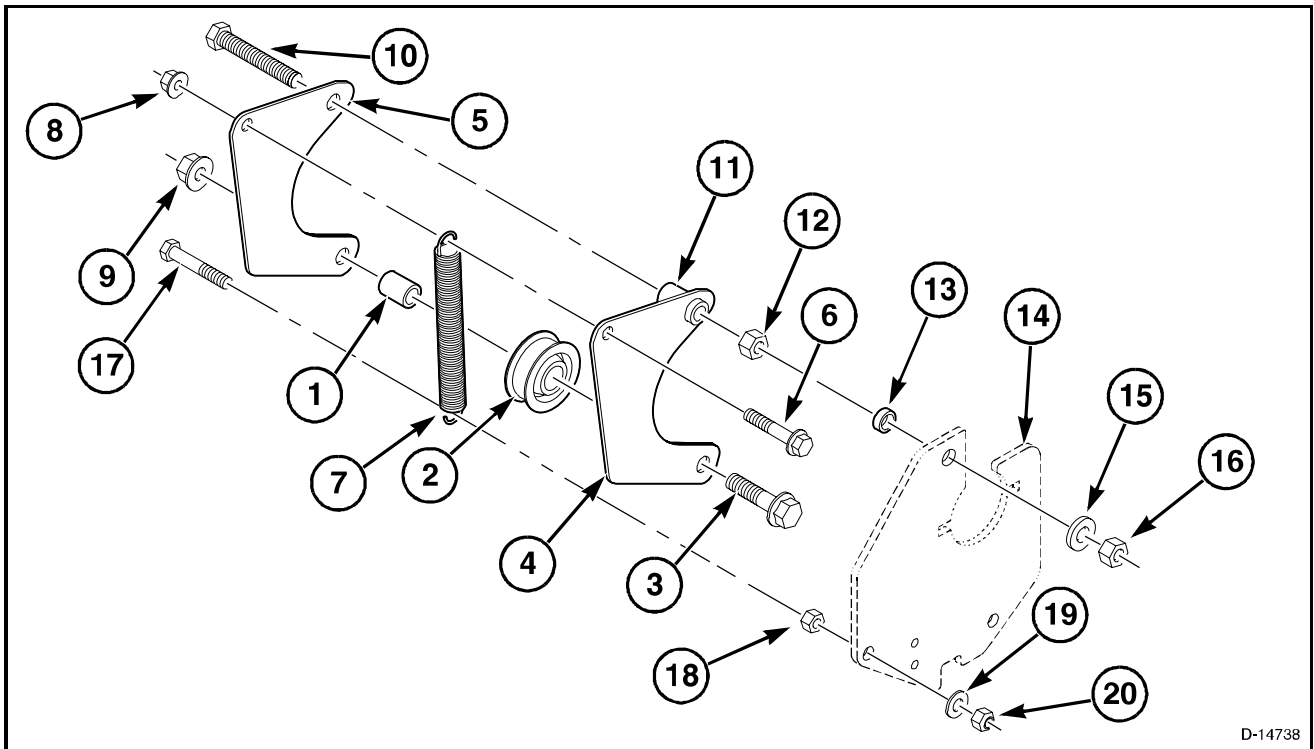

D-14738

FIG. 9

FIG. 9: Grease idler pulley.

Insert spacer (1) into pulley (2).

Insert bottom screw flange (3) through chain tightener (4), pulley (2), and arm tightener (5).

Insert top flange screw (6) through the tighteners (4,5) and the spring (7).

Tighten the flange lock nuts (8,9). Do not overtighten, idler pulley needs to be able to move freely.

Insert top cap screw (10) through tightener arm (5), spacer (11), chain tightener (4), center lock nut (12), spacer (13), plate mount (14), washer (15), and tighten center lock nut (16).

Insert bottom cap screw (17) through spring (7), nut (18), plate mount (14), washer (19), and tighten center lock nut (20).

Do not overtighten, idler pulley needs to be able to move freely.

Attach roller chain.

Hydraulic Drive

LOWER IDLER PULLEY

Removal

FIG. 10: Remove roller chain.

Remove cap screw.

Remove idler pulley. Replace if necessary.

Remove washers and spacers.

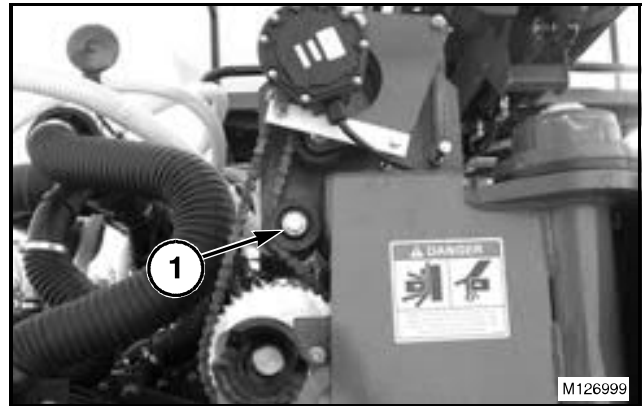

FIG. 10

Installation

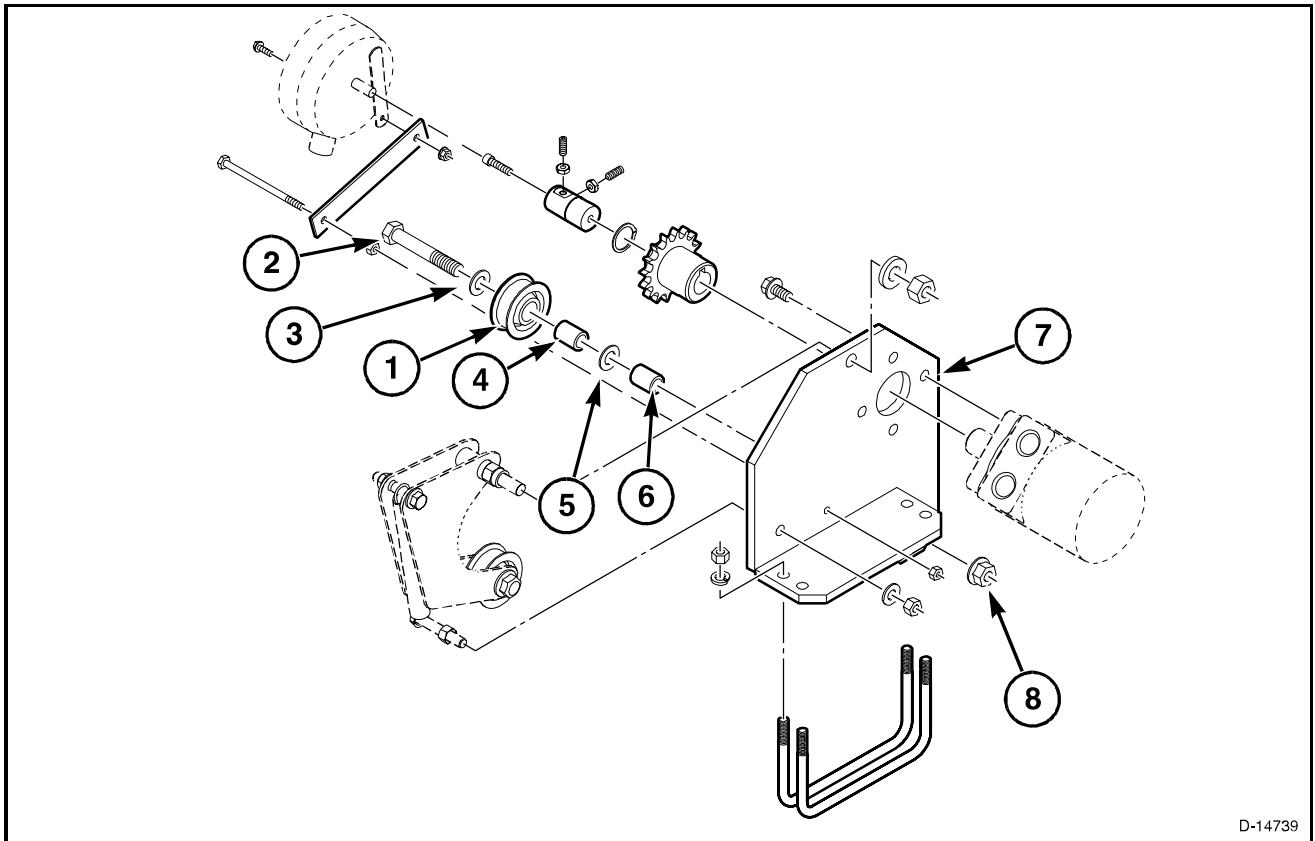

FIG. 11

FIG. 11: Grease idler pulley (1).

Insert cap screw (2) through washer (3), idler pulley, spacer (4), washer (5), spacer (6), and mounting plate (7).

Tighten center lock nut (8).

40 TOOTH SPROCKET

Operation

The 40 tooth sprocket is connected to and turns the drive shaft.

Removal

Remove drive chain.

FIG. 12: Loosen the set screws in the four lock collars (1).

Remove the two slotted spring pins (2).

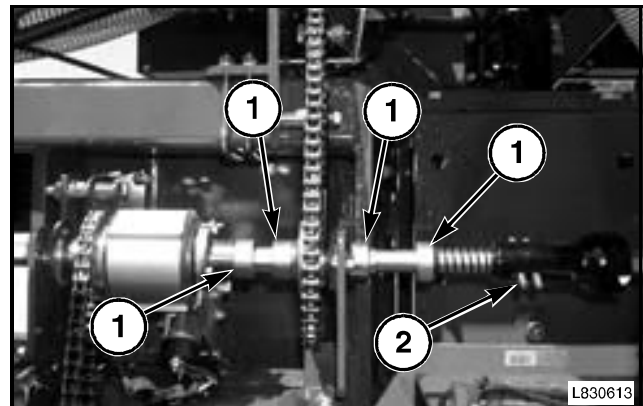

FIG. 12

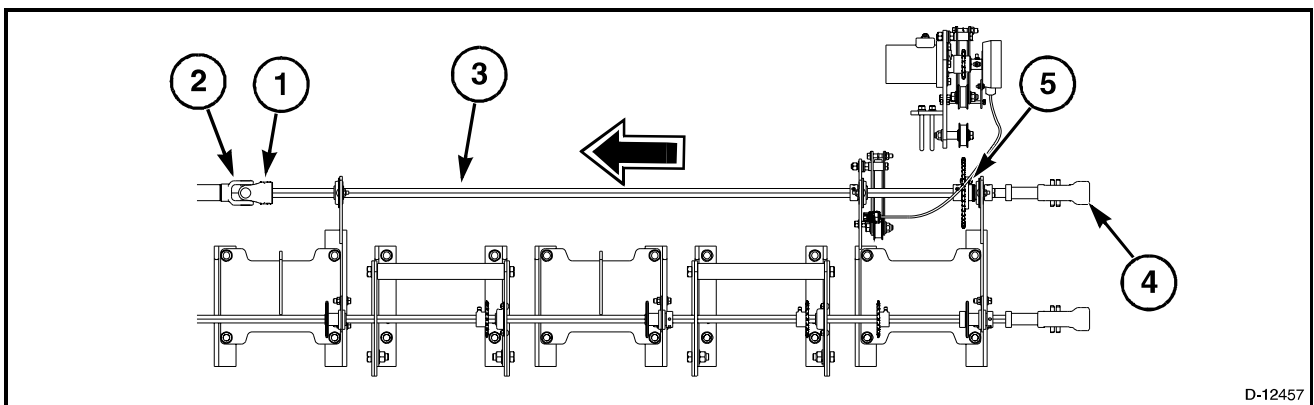

FIG. 13

FIG. 13: Place planter in folded position when removing drive shaft.

Remove the pin (1) from the yoke (2). Slide the yoke off the drive shaft (3).

Remove the coupling assembly (4).

Slide drive shaft out and remove the 40 tooth sprocket (5).

Hydraulic Drive

FIG. 14: Remove flange screw (1) to separate drive hub (3) from the 40 tooth sprocket (3).

Clean or replace the 40 tooth sprocket if needed.

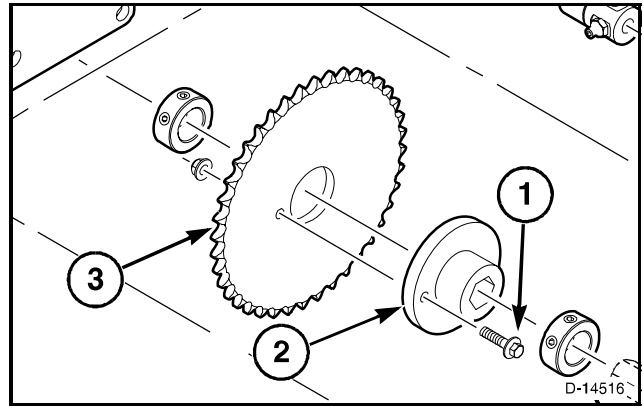

FIG. 14

Installation

FIG. 15: Screw drive hub to the 40 tooth sprocket.

Insert drive shaft through the two lock collars (1), the 40 tooth sprocket and drive hub assembly (2), lock collar (3), and the right angle plate (4).

Attach coupling assembly (5) back in original position.

Connect the drive shafts by inserting the pin into the yoke. Insert grease into the grease fitting.

Align the 40 tooth sprocket with the 16 tooth sprocket and idler pulleys.

Tighten all lock collars in proper location.

Install roller chain.

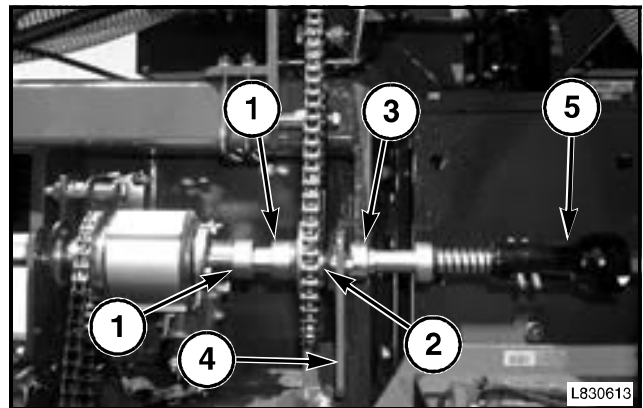

FIG. 15

POINT ROW CLUTCHES AND UPPER DRIVE SHAFT

GENERAL INFORMATION

The upper drive shaft is the output shaft from the hydraulic drive motor. The output shaft provides power to the drive shaft sections, which provides power to the row units, which turns the seed meters.

ROLLER CHAINS

Operation

There are three point row clutches each with a roller chain connecting the point row clutch to the lower drive shaft.

Removal

FIG. 16: Push in the pulley idler (1) to reduce tension.

With tension reduced, remove the 70 link roller chain (2) from the sprockets.

Inspect roller chain. Replace as required.

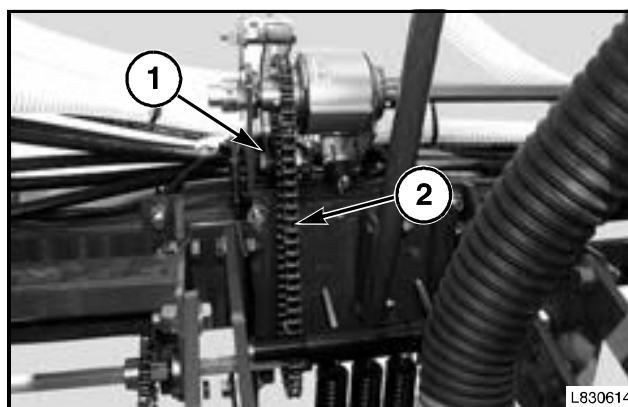

FIG. 16

Installation

Place roller chain on sprockets.

Push on idler pulley to allow the chain to go on the idler pulley.

Insert roller chain onto the idler pulley and release the idler pulley to increase tension.

Make sure the roller chain is fitted on all the sprockets correctly.

Point Row Clutches and Upper Drive Shaft

POINT ROW CLUTCH

General Information

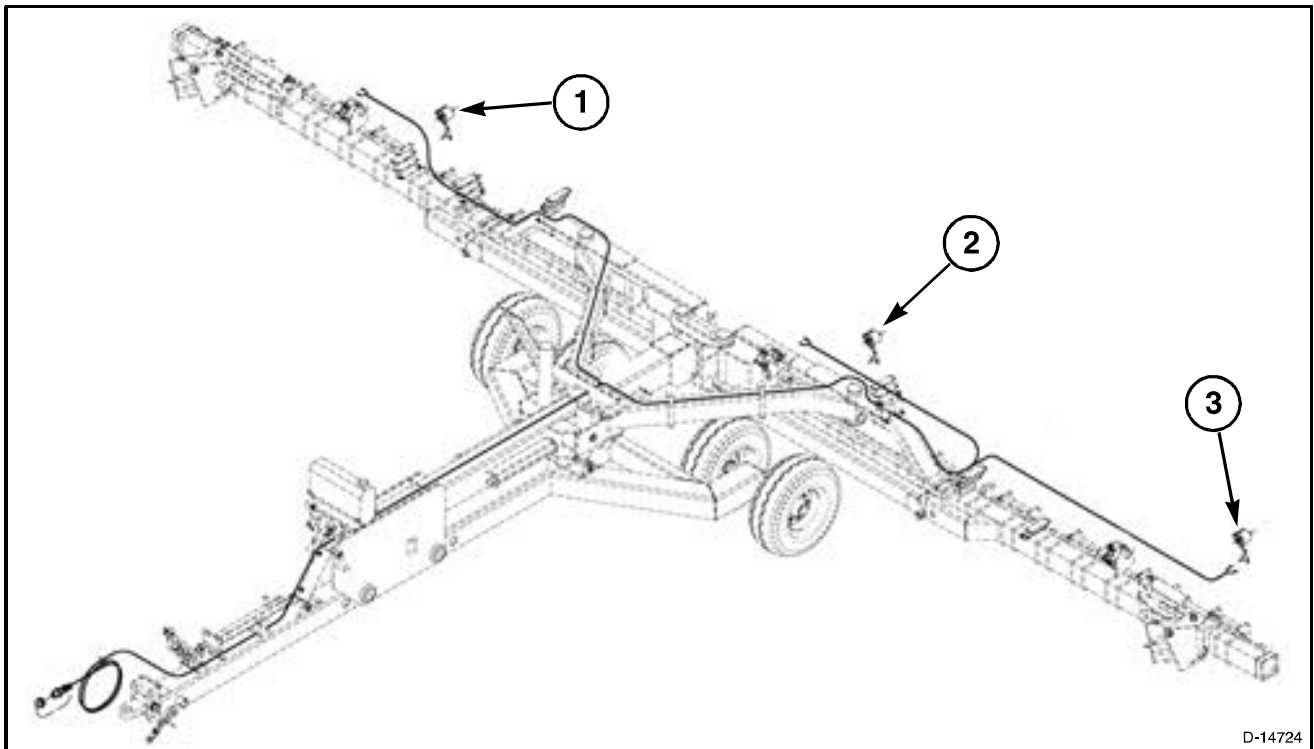

FIG. 17

FIG. 17: There are three point row clutches on the upper drive shaft, which is used to allow different sections of the drive shaft to be engaged and disengaged. The point row wing shut-off clutch reduces over seeding when planting end rows. The center point row shut-off clutch disengages the drive for the row units on the center section. The left and right point row shut-off clutches disengage the wings.

- (1) Left point row clutch
- (2) Center point row clutch
- (3) Right point row clutch

NOTE: Point row clutches are optional. If there is not a point row clutch then there will be a 20 tooth sprocket like the lower shaft sprocket instead.

All three point row clutches are right-hand point row clutches and are assembled in the same manner.

Point Row Clutches and Upper Drive Shaft

Clutch Control Box

FIG. 18: If the planter is equipped with optional point row clutches, a three switch control box is mounted in the cab. Each ON-OFF switch controls row unit operation for the wings and center frame:

- Left-hand side switch for left wing row units
- Right-hand side switch for right wing row units
- Center switch for center section

Push the toggle switch down, ON, to engage each clutch.

Push the toggle switch up, OFF, to disengage each clutch.



FIG. 18

Point Row Clutches and Upper Drive Shaft

REMOVAL

Left Point Row Clutch

FIG. 19: Disconnect the straight eye wires from the solenoid (1).

- Red (+)
- Black (-)

Remove roller chains.

Loosen the two lock collars (2) on the drive shaft.

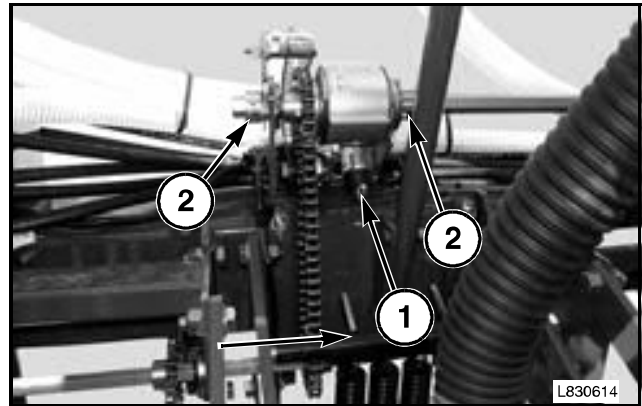

FIG. 19

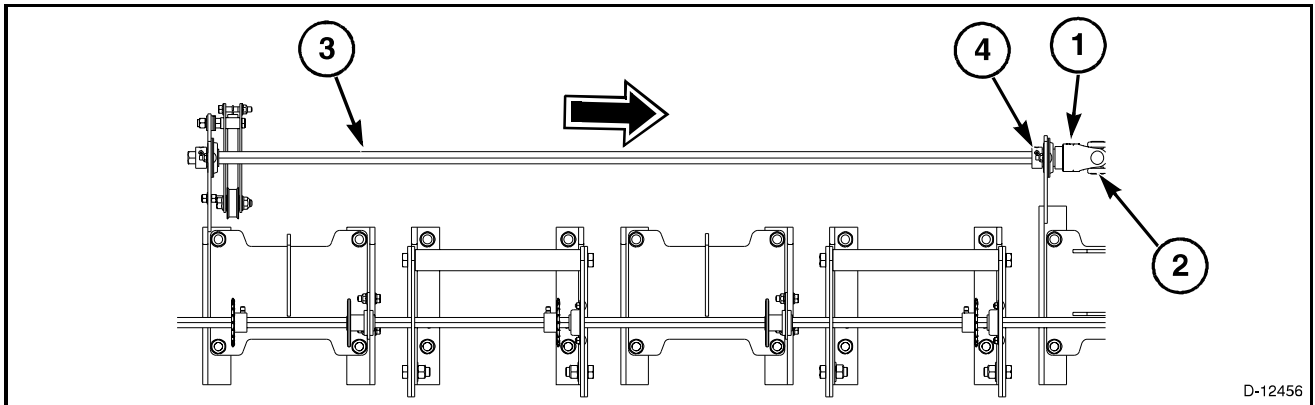

FIG. 20

FIG. 20: Remove the pin (1) from the yoke (2). Remove the yoke from the left, upper drive shaft (3).

NOTE: Planter is in transport position to remove or install drive shaft.

The left, upper drive shaft (3) is 162 cm (63.8 in) long.

Loosen the set screws on the lock collar (4).

Slide the upper drive shaft out.

FIG. 21: Remove the cap screw (1) and nut and remove the point row clutch assembly (2) from the angle (3).

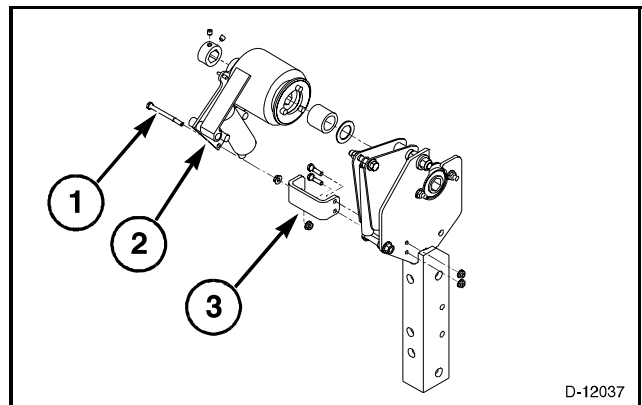

FIG. 21

Point Row Clutches and Upper Drive Shaft

Center Point Row Clutch

FIG. 22: Disconnect the straight eye wires from the solenoid (1).

- Orange (+)
- Blue (-)

Remove roller chains.

Loosen the four lock collars (2) on the hex shaft.

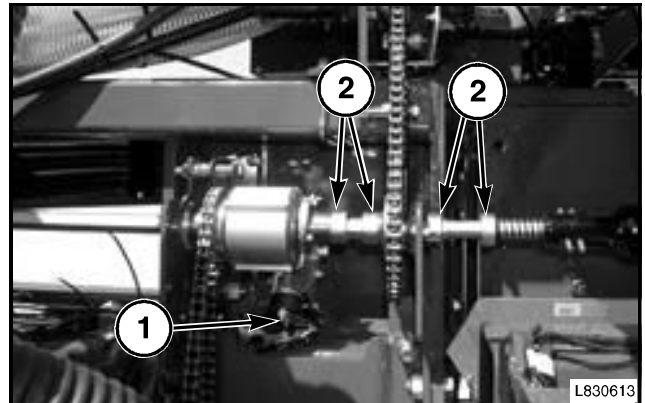

FIG. 22

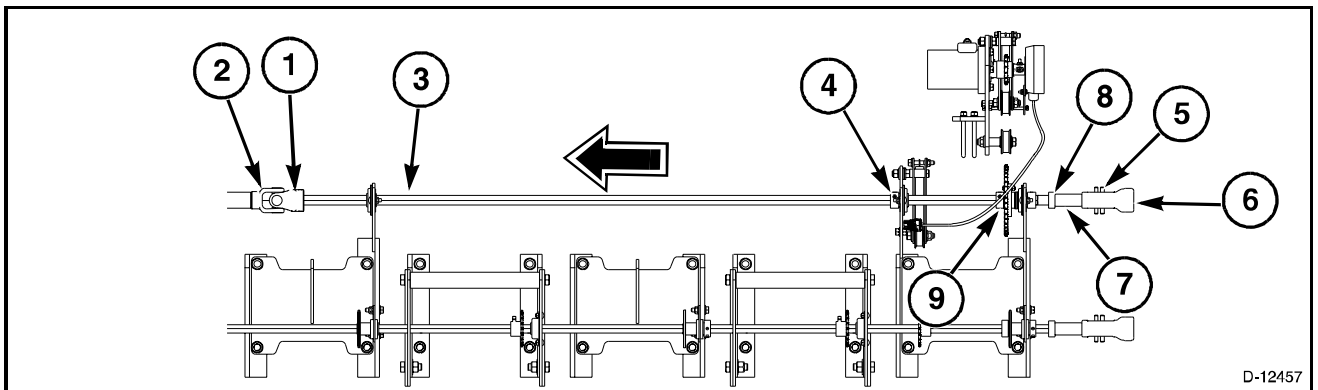

FIG. 23

FIG. 23: Remove the pin (1) from the yoke (2). Remove the yoke from the upper drive shaft (3).

NOTE: Planter is in transport position to remove or install drive shaft.

The left center, upper drive shaft (3) is 192.8 cm (75.9 in) long.

Loosen the set screws on the lock collar (4).

Remove the roll pins (5) from the coupling (6). Remove the coupling, spring (7), and the lock collar (8)

Slide the drive shaft to the left and remove the 40 tooth sprocket (9).

Point Row Clutches and Upper Drive Shaft

FIG. 24: Remove the cap screw (1) and nut and remove the point row clutch (2) from the angle (3).

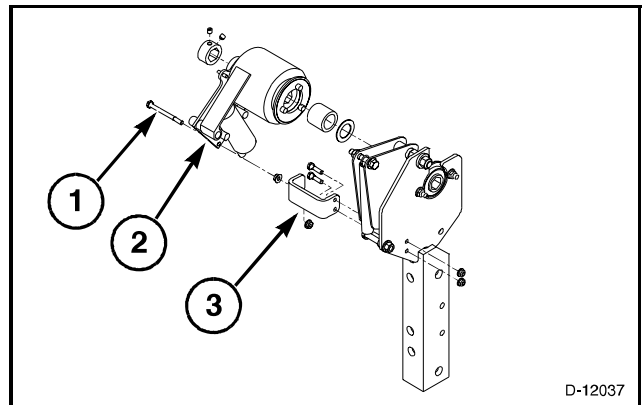

FIG. 24

Right Point Row Clutch

FIG. 25: Disconnect the straight eye wires from the solenoid.

- Yellow (+)
- Brown (-)

Remove roller chain.

Remove the lock collar on the upper drive shaft (1).

The right, upper drive shaft (1) is 162 cm (63.8 in) long.

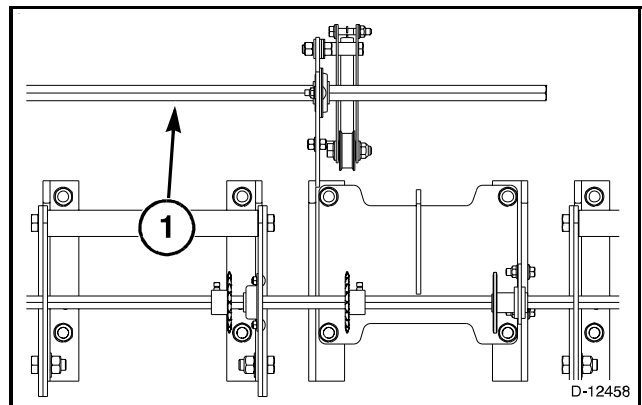

FIG. 25

FIG. 26: Remove the cap screw (1) and nut and remove the point row clutch (2) from the angle (3).

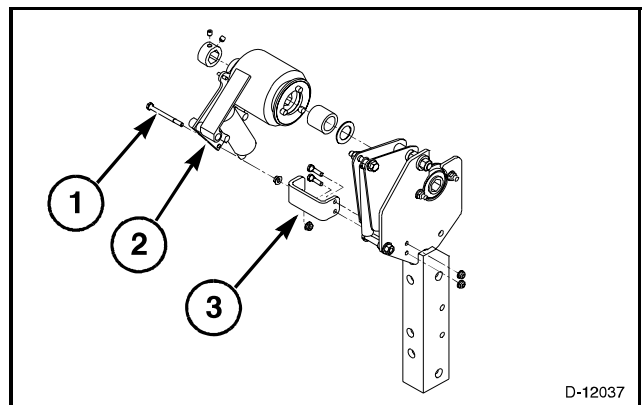

FIG. 26

Point Row Clutches and Upper Drive Shaft

DISASSEMBLY

FIG. 27: Remove the solenoid (1) and spring (2).

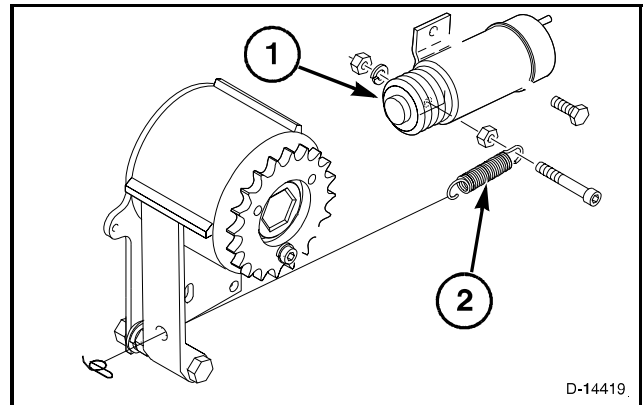

FIG. 27

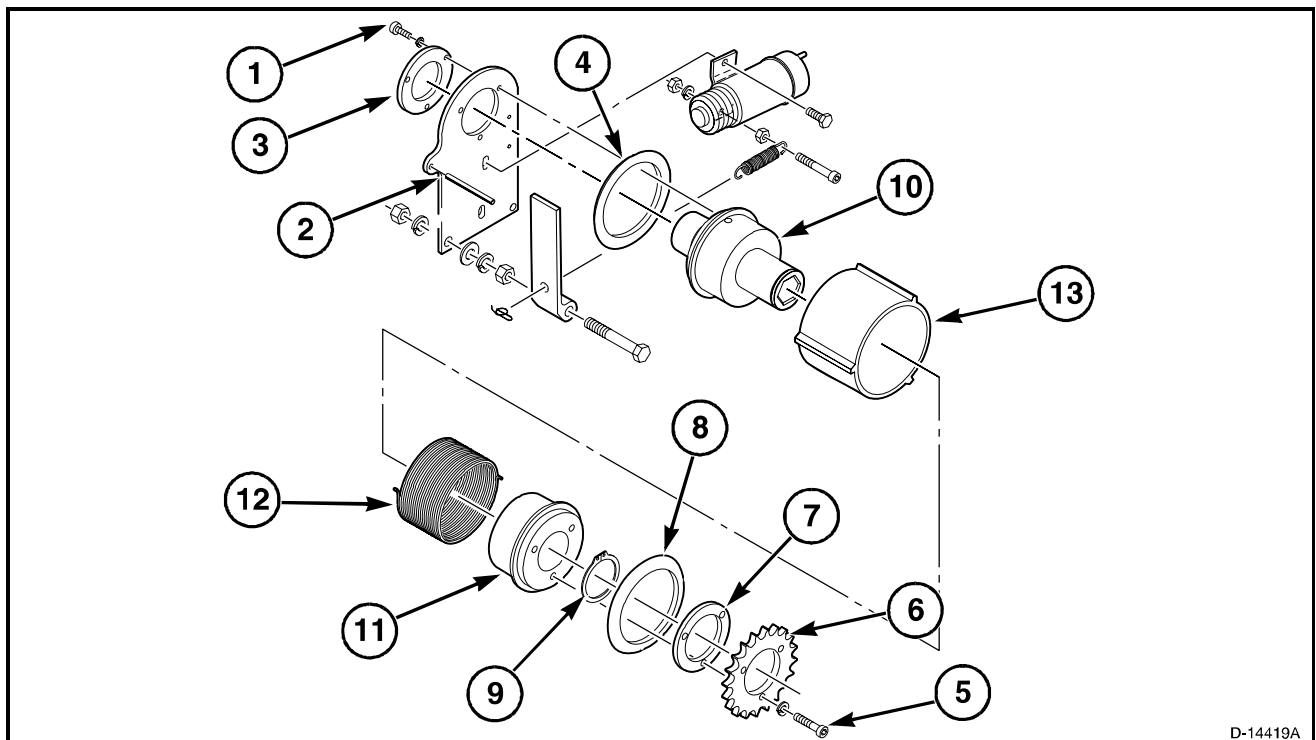

FIG. 28

FIG. 28: Remove the three socket cap screws (1) and lock washers from the solenoid bracket (2).

Remove the bushing (3), hub, and sleeve assembly.

Replace seal (4) if necessary.

Unscrew the three socket cap screws (5).

Remove the 20 tooth drive sprocket (6).

Remove spacer (7).

Replace seal (8) if necessary.

Unclip snap ring (9) from hub (10).

Remove driven sleeve (11), torsion spring (12), and release sleeve (13) from hub.

Replace any damaged or worn components.

Point Row Clutches and Upper Drive Shaft

ASSEMBLY

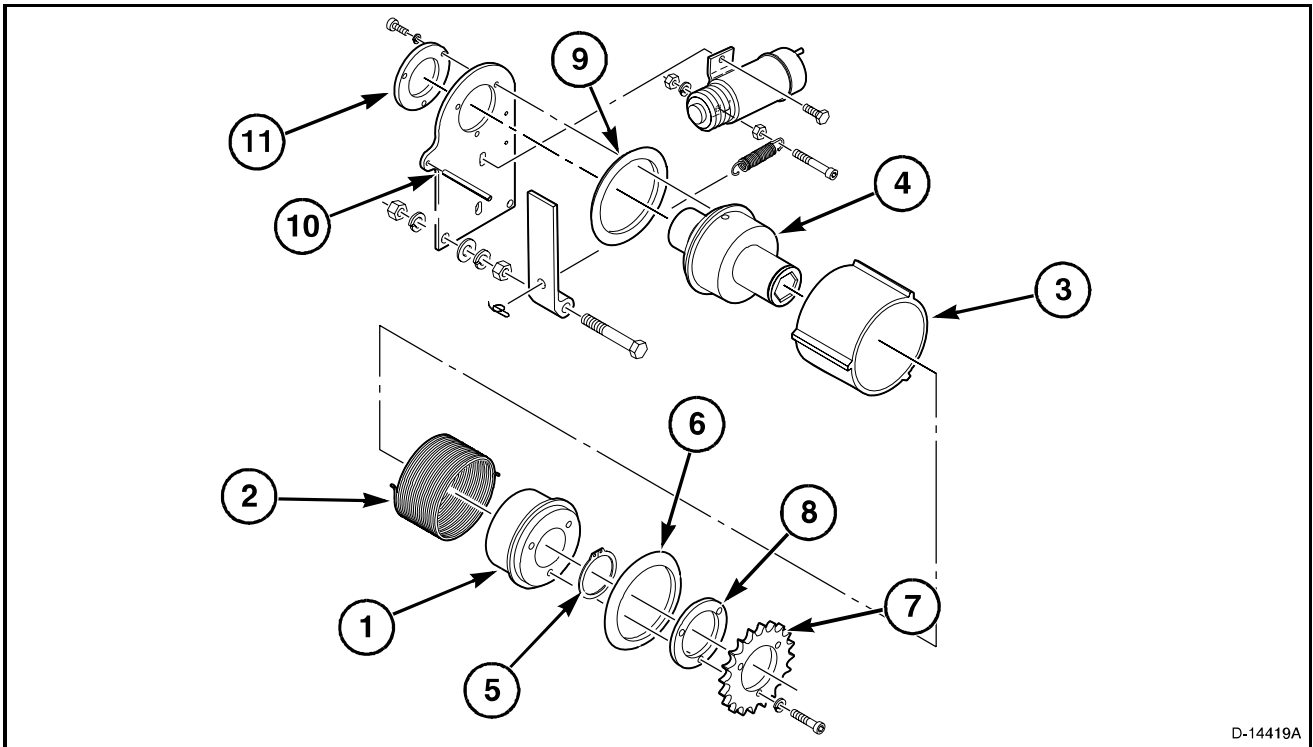

D-14419A

FIG. 29

FIG. 29: Insert driven sleeve (1) into torsion spring (2).

Insert driven sleeve and torsion spring into release sleeve (3).

Insert hub (4) into sleeve assembly and attach snap ring (5).

Place seal (6) in driven sleeve groove.

Line sprocket (7) holes up with spacer (8) and screw to driven sleeve.

Place seal (9) on hub and insert into solenoid bracket (10).

Align the bushing (11) holes up with the holes in the bracket and hub and screw together.

FIG. 30: Attach solenoid (1) and spring (2) to clutch.

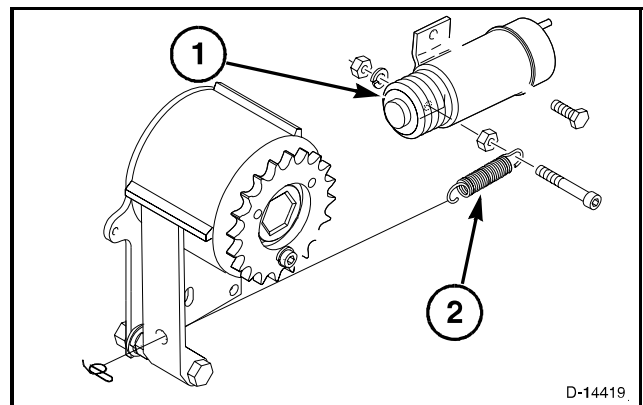

D-14419

FIG. 30

INSTALLATION

Left Point Row Clutch

FIG. 31: Install the washer (1), spacer (2), point row clutch (3), and lock collar (4) onto the shaft. Move the drive shaft back to the original position.

Slide assembly against the support.

Install cap screw (5) through point row clutch, serrated nut (6), and angle (7).

Install serrated lock nut (8) on the inside of the angle and tighten.

Tighten the set screws (9) in the lock collar.

Make sure the clutch does not bind on the shaft.

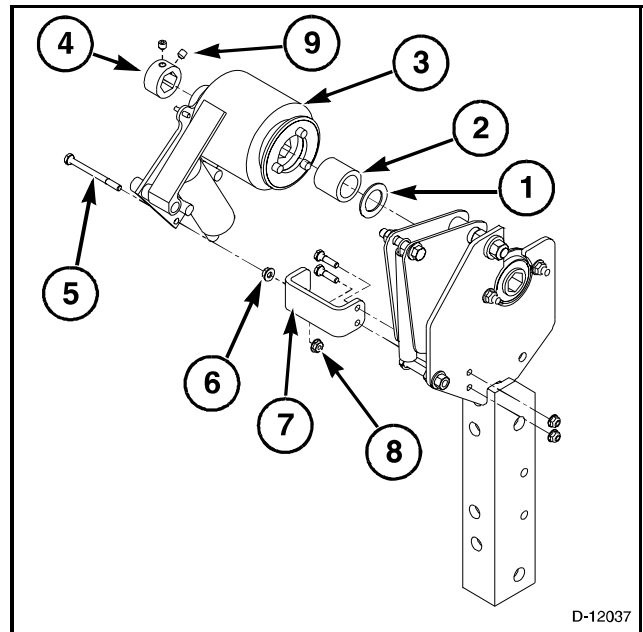

FIG. 31

Thank you so much for reading.
Please click the “Buy Now!”
button below to download the
complete manual.



After you pay.

You can download the most
perfect and complete manual in
the world immediately.

Our support email:

ebooklibonline@outlook.com