

Massey Ferguson®

2846 / 2846A / 2856 / 2856A
Round Baler

SERVICE MANUAL 4283398M2

CONTENTS

GENERAL INFORMATION	01
DRIVE	02
PICKUP	03
ELECTRICAL	04
BALE FORMING	05
BALE WRAPPING	06
CHASSIS	07
HYDRAULICS	08
CONSOLE I	09
RESERVED	10

Massey Ferguson®

2846 / 2846A / 2856 / 2856A
Round Baler

WORKSHOP SERVICE MANUAL
4283398M2

02 - Drive

Contents

DRIVE SYSTEM

Main Drive Clutch	02-1
Description	02-1
Removal	02-1
Components	02-2
Disassembly	02-2
Inspection	02-3
Assembly	02-4
Installation	02-6
Adjustment	02-6
Main Drive Shaft	02-7
Removal	02-7
Installation	02-9
Starting Roll and Lower Drive Roll	02-11
Removal	02-11
Installation	02-14
Shearbar (Optional)	02-16
Overrunning Clutch	02-16
Description	02-16
Removal	02-16
Disassembly	02-17
Assembly	02-18
Installation	02-20
Upper Drive roll	02-22
Removal	02-22
Installation	02-22
Drive Speed Change	02-23
Gearbox	02-25
Removal	02-25
Components	02-26
Important Notes	02-27
Disassembly And Inspection	02-27
Assembly	02-27
Installation	02-30

DRIVE LINE

Inspection	02-31
Drive Line Removal and Installation	02-31
Drive Line Shield Removal and Installation	02-32
Shields With Lock Clips	02-32
CV Joint Bearing Replacement	02-33
Disassembly	02-33
Inspection	02-37

Contents

Assembly	02-38
Universal Joint Bearing Replacement	02-49
Disassembly	02-49
Assembly	02-51
Quick Disconnect Yoke	02-57
Disassembly	02-57
Assembly	02-58
ROLLER CHAINS	
Lubrication	02-61
Lubricants	02-61
Indication of Good Roller Chain Lubrication	02-61
Roller Chain Lubrication	02-61
Removing to Clean and Lubricate	02-61
O-Ring Roller Chain (If Equipped)	02-62
Removal and Installation	02-62
Removal	02-62
Installation	02-62
Inspection	02-63
Roller Chain Elongation	02-63
Sprocket Wear	02-64
Sprocket Alignment	02-65
Tension	02-66
Starting Roll Chain	02-66
Pickup Chain	02-66
Feeder Chain	02-67
Hydraulic Pump Chain	02-67
Upper Drive Roll Chain	02-67
Lower Drive Roll Chain	02-68
Threader Chain	02-68
INDEX	02-69

DRIVE SYSTEM

MAIN DRIVE CLUTCH

Description

FIG. 1: The main drive clutch (1) is spring actuated and hydraulically released. The main drive clutch disengages the pickup, stuffer, upper and lower drive rolls, and starting roll when the tailgate opens.

The main drive clutch gives overload protection for all the mechanical components. When the torque limit is reached, the main drive clutch slips to stop the forming belt drive system.

If the main drive clutch slips, disengage the PTO. Stop the tractor engine, take the key with you and correct the condition.

The clutch torque is set at the factory for 1462 to 2138 Nm (1078 to 2019 lbf ft).

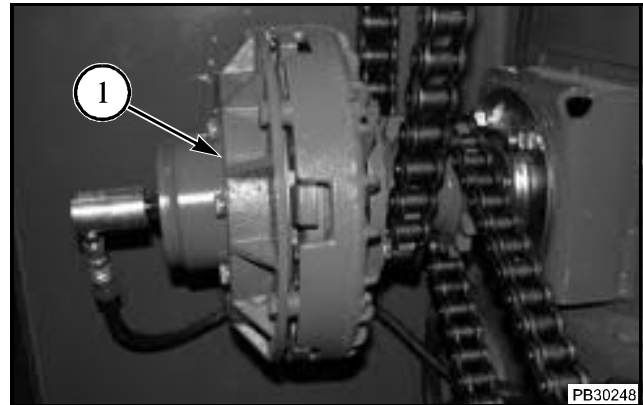

FIG. 1

Removal

FIG. 2: Use a detergent solution and a low pressure spray washer to clean the clutch area.

Remove the hydraulic rotary union fitting (1) from the clutch cylinder (2).

IMPORTANT: The hydraulic rotary union has left-hand threads. Make sure to turn correctly to prevent damage.

NOTE:

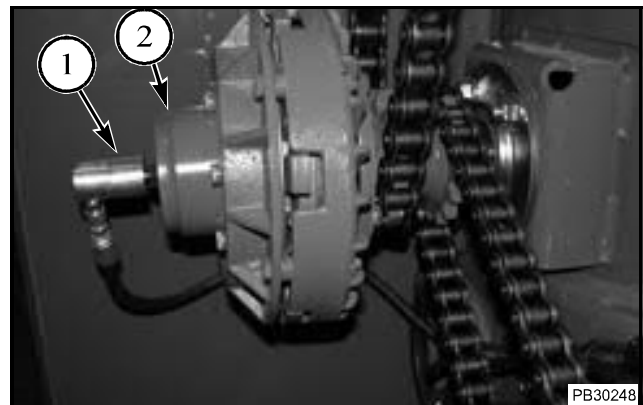

FIG. 2

FIG. 3: The clutch (1) is held to the drive sprocket assembly (2) with four 3/8-16 x 1 capscrews (3), located on the back side of the clutch.

To remove the clutch, hold the clutch and remove the four 3/8-16 x 1 cap screws and washers.

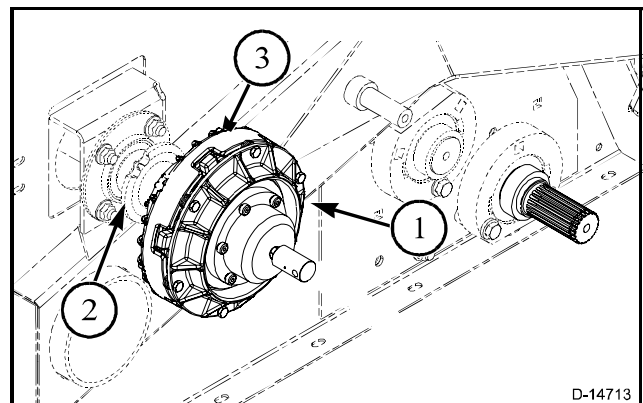

FIG. 3

Drive System

Components

FIG. 4: Main Drive Clutch

- (1) 5/16-18 x 2-1/2 cap screws (six).
- (2) Hardened plain washers (twenty-four)
- (3) Compression plate
- (4) Disc spring
- (5) Pressure plate
- (6) Puller plate
- (7) Friction disc
- (8) Clutch housing

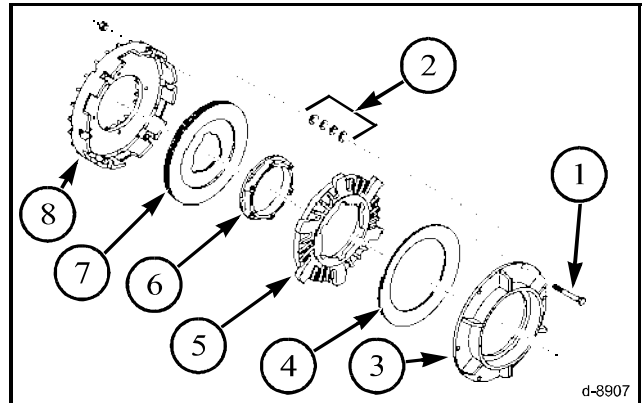

FIG. 4

Disassembly

FIG. 5: If the rotary union (1) is still installed, remove the rotary union (1) from the hydraulic cylinder (2). There is a brass washer between the rotary union and the hydraulic cylinder.

IMPORTANT: The rotary union has **LEFT-HAND** threads. Make sure the nut is removed in a clock-wise direction or the threads to the bolt will be damaged.

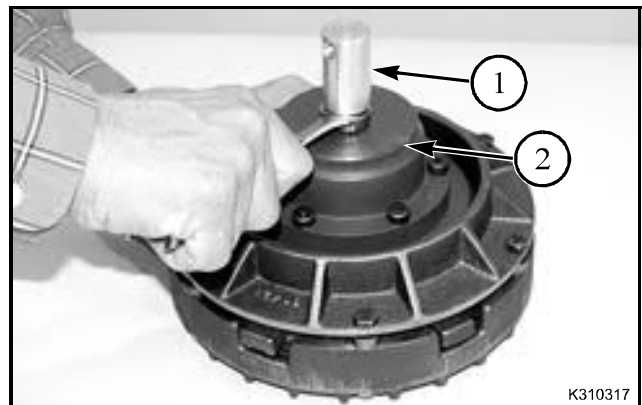

FIG. 5

FIG. 6: Remove the six hex socket head shoulder screws (1) from the hydraulic cylinder (2). Remove the hydraulic cylinder.

Loosen the six 5/16-18 x 2-1/2 cap screws (3) alternately and evenly. Remove the six cap screws and 24 hardened plain washers (4).

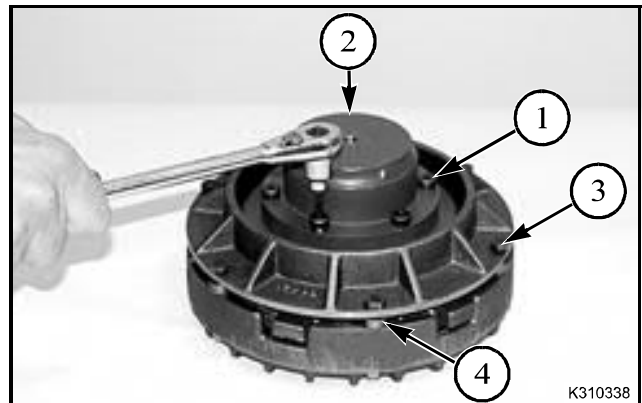

FIG. 6

FIG. 7: Remove the compression plate (1).

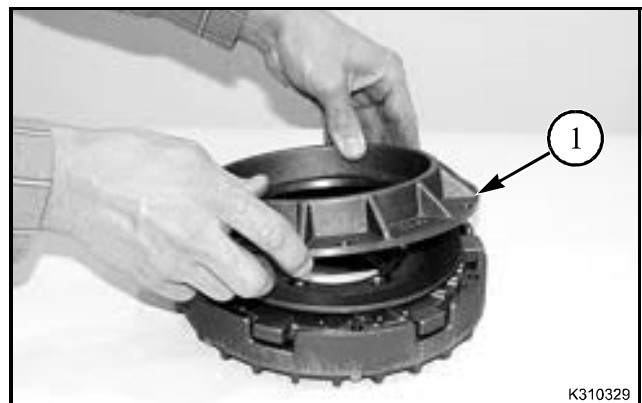

FIG. 7

FIG. 8: Remove the disc spring (1).

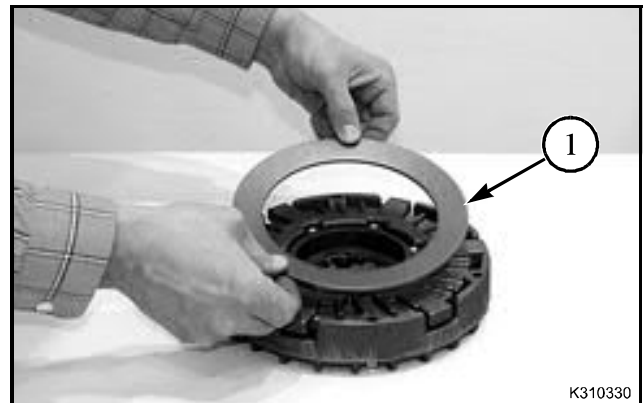

FIG. 8

FIG. 9: Remove the pressure plate (1).

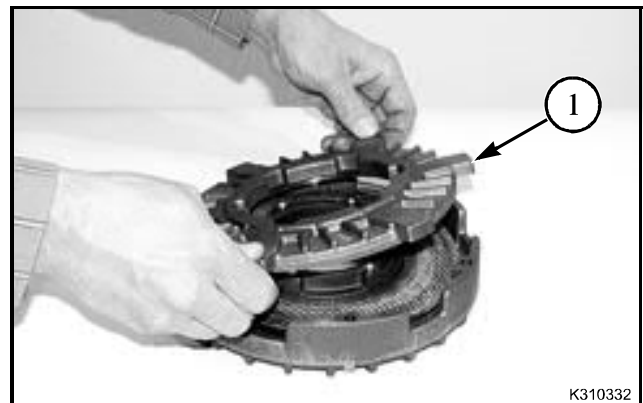

FIG. 9

FIG. 10: Remove the puller plate (1).

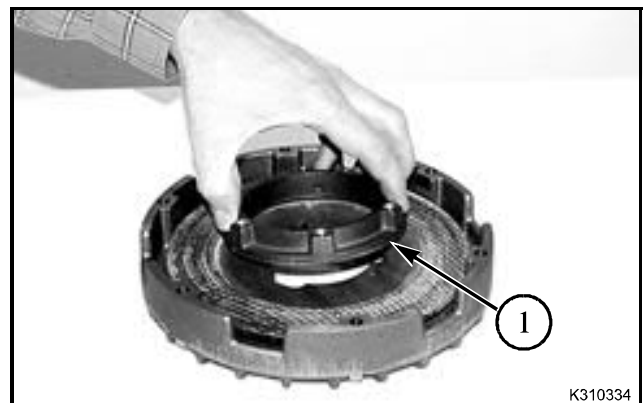

FIG. 10

FIG. 11: Remove the friction disc (1).

Inspection

Inspect the clutch components for wear and replace as necessary.

The surfaces on the pressure plate and clutch housing that contact the friction disc must be smooth and without grooves.

Inspect the friction disc for wear. A new friction disc is 12.7 mm (0.5 in) thick.

Inspect the disc spring for distortion. A new disc spring is 10.4 mm (0.410 in) high.

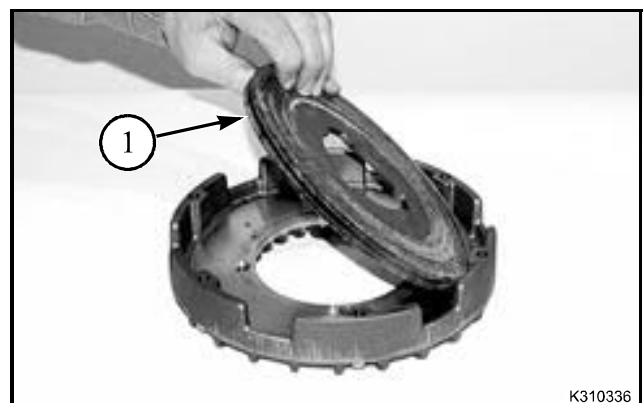

FIG. 11

Drive System

Assembly

FIG. 12: Put the friction disc (1) into the clutch housing (2).

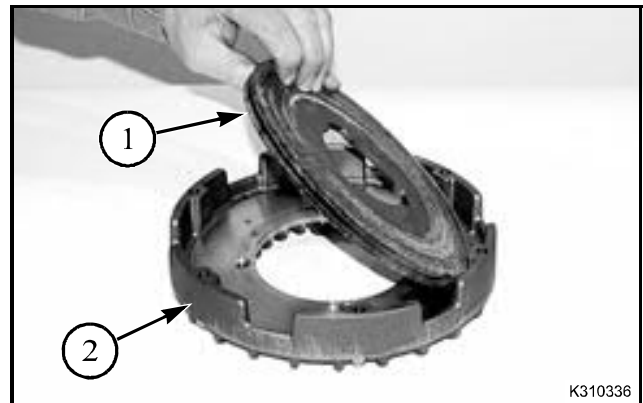

FIG. 12

FIG. 13: Put the puller plate on the friction disc (1).

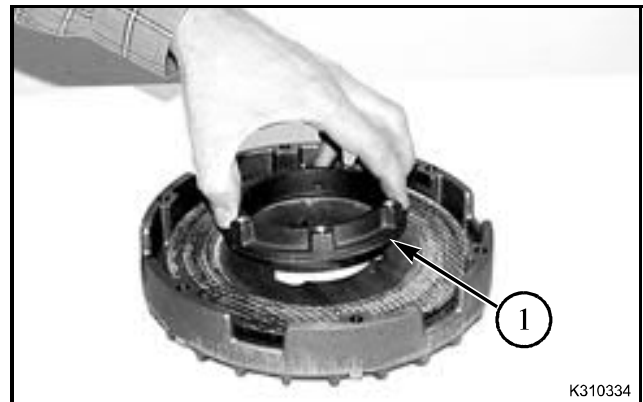

FIG. 13

FIG. 14: Put the pressure plate (1) onto the friction disc and puller plate. The tabs on the pressure plate must go into the slots in the clutch housing.

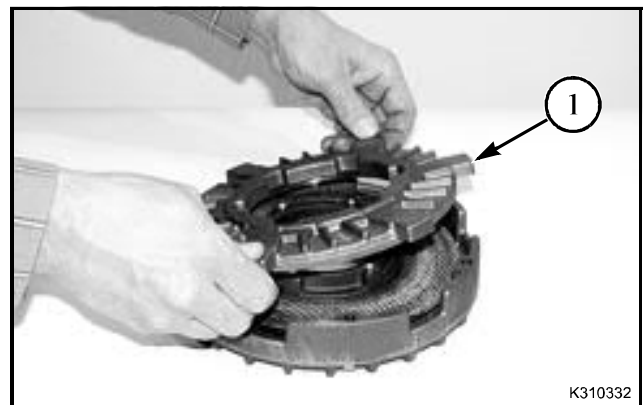

FIG. 14

FIG. 15: Put the disc spring (1) on the pressure plate. Make sure the disc spring is held in position by the spring tabs (2) on the pressure plate. The spring must be installed so the center is low and the outside is high.

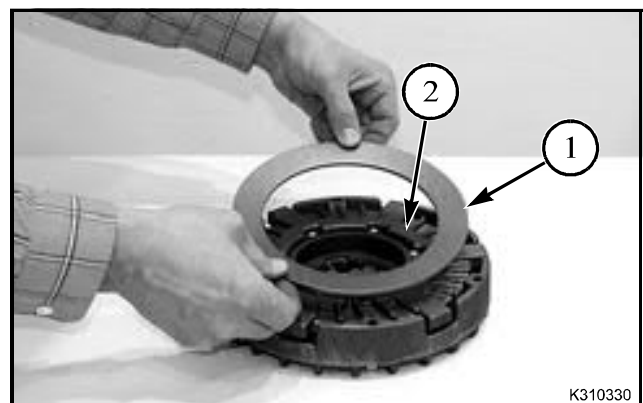

FIG. 15

FIG. 16: Install the compression plate (1) using six 5/16-18 x 2-1/2 cap screws (2) and 24 hardened plain washers (3). When a new friction disc has been installed, four washers are put between the compression plate and clutch housing for each cap screw. The clutch is adjusted by adding or removing washers under the compression plate.

Tighten the cap screws alternately and evenly to 33 Nm (25 lbf ft).

Measure the gap (A) between the compression plate (1) and the pressure plate tab. The gap must be between 7 to 9 mm (1/4 to 11/32 in). If the gap is not correct, then remove the cap screws. Move washers from under the compression plate to on top of the compression plate. Tighten the cap screws alternately and evenly to 33 Nm (25 lbf ft) and check the gap.

Apply Loctite® Primer N and then Loctite® 243 to the six hex socket head shoulder screws (4). Install the hydraulic cylinder (5) using the six hex socket head shoulder screws. The screws must be tightened to 24 Nm (17 lbf ft).

FIG. 17: Put Loctite® 545 on the threads on the rotary union (1). Install the rotary union onto the hydraulic cylinder. Be sure to install the brass washer (2) between the rotary union and the hydraulic cylinder.

NOTE: The rotary union has left-hand threads.

It is recommended to install the hydraulic hose to the union and then install the union in the cylinder after the clutch is installed on the machine.

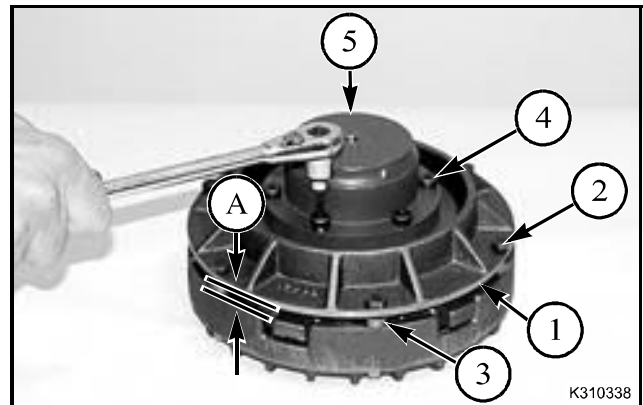

FIG. 16

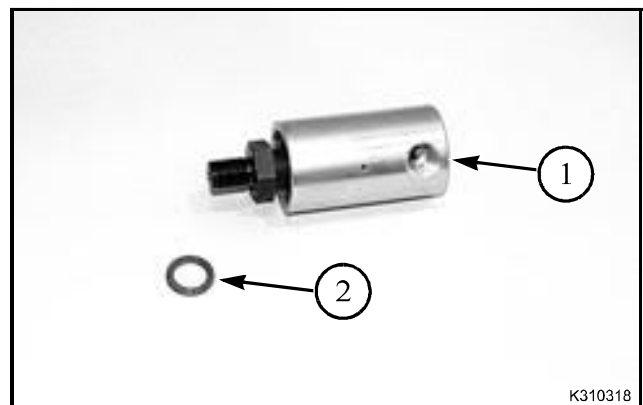

FIG. 17

Drive System

Installation

FIG. 18: Put the clutch (1) into position. Make sure the tabs in the friction plate line up with the notches in the clutch hub (2). Install the four cap screws (3) and washers.

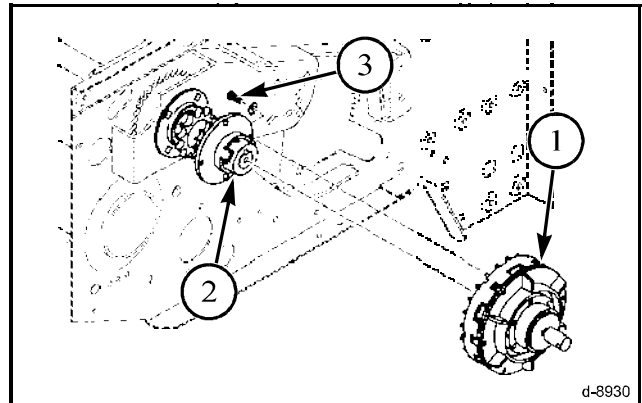

FIG. 18

Adjustment

FIG. 19: The main drive clutch (1) must be adjusted if excessive slipping occurs or if the clutch has been disassembled.



WARNING: ALWAYS disengage the tractor PTO, put the tractor transmission in park and apply the tractor parking brake. Stop the tractor engine and remove the key before servicing or doing any maintenance on the machine.

Measure the gap (A) between the outer plate (2) and the pressure plate lug (3) with no hydraulic pressure applied to the cylinder (clutch engaged). The gap must be between 7 to 9 mm (1/4 to 11/32 in). Adjust if necessary.

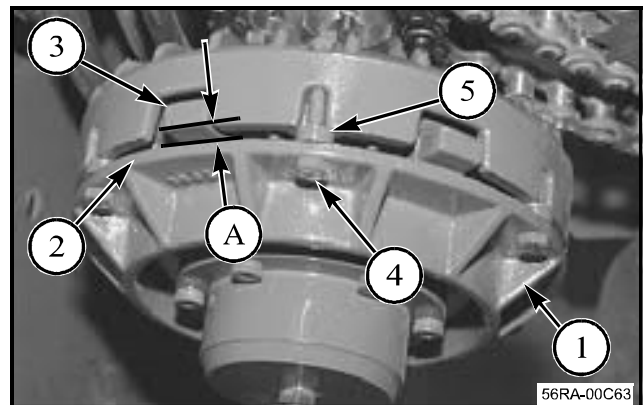

FIG. 19

To adjust the main drive clutch:

- Loosen the six bolts (4) that fasten the outer plate to the clutch housing.
- Remove one of the bolts. Hold and remove the washers (5) with a magnet. Move one washer from the gap to under the head of the bolt.
- Install the bolt with the washers in the new order.
- Repeat the procedure for the remaining five bolts.
- Tighten the bolts alternately and evenly to 33 Nm (25 lbf ft).
- Measure the gap again. Adjust as necessary to get the correct gap.

MAIN DRIVE SHAFT

NOTE: To remove, repair, and replace the main drive clutch, refer to the main drive clutch removal section.

Removal

FIG. 20: Use a detergent solution and a low pressure spray washer to clean the clutch area.

Remove the rotary union fitting (1).

Remove the upper drive roll chain (2) and the starting roll (3).

IMPORTANT: The rotary union has LEFT-HAND threads. Make sure the nut is removed in a clock-wise direction or the threads to the bolt will be damaged.

NOTE: The clutch, cylinder, and rotary union can be removed and set aside as a unit. This can be done by removing the four cap screws (4) and removing the assembly. The hose is long enough to let the clutch rest on top of the stuffer frame. Make sure to not damage the rotary union.

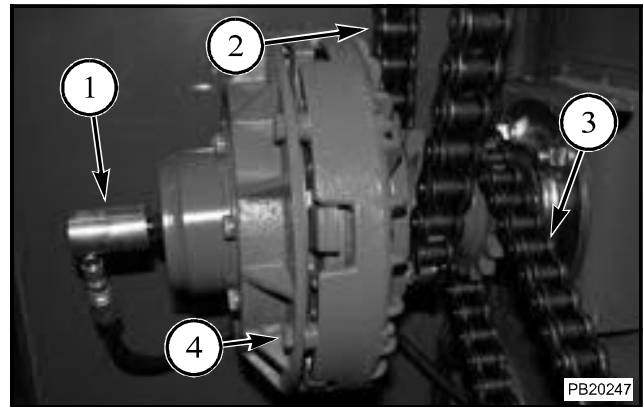

FIG. 20

FIG. 21: To remove the clutch (1), hold the clutch and remove the four cap screws (2) and washers.

Loosen the two set screws and remove the clutch hub (3).

NOTE: The set screws are not the same length. The short set screw is put into the hole over the key slot.

Remove the key (4).

Remove the two bushings (5).

Make sure the shaft is clean. Slide the drive sprocket (6) assembly off of the shaft.

Remove the gauge machinery bushings (7).

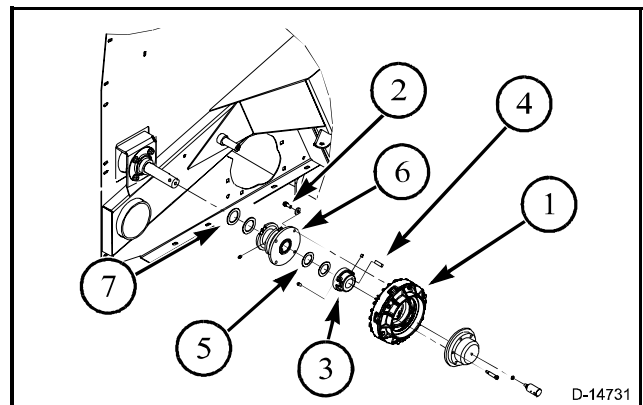

FIG. 21

FIG. 22: The needle bearings (1) in the drive sprocket assembly (2) can be replaced if necessary. Press out the old bearings. Install the new bearings with the seals to the outside.

IMPORTANT: Make sure to press bearing (1) in against shoulder. The bearing will be recessed on the sprocket side of the sprocket assembly.

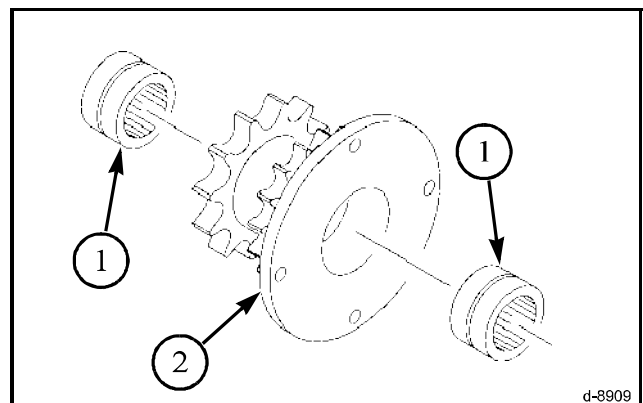

FIG. 22

Drive System

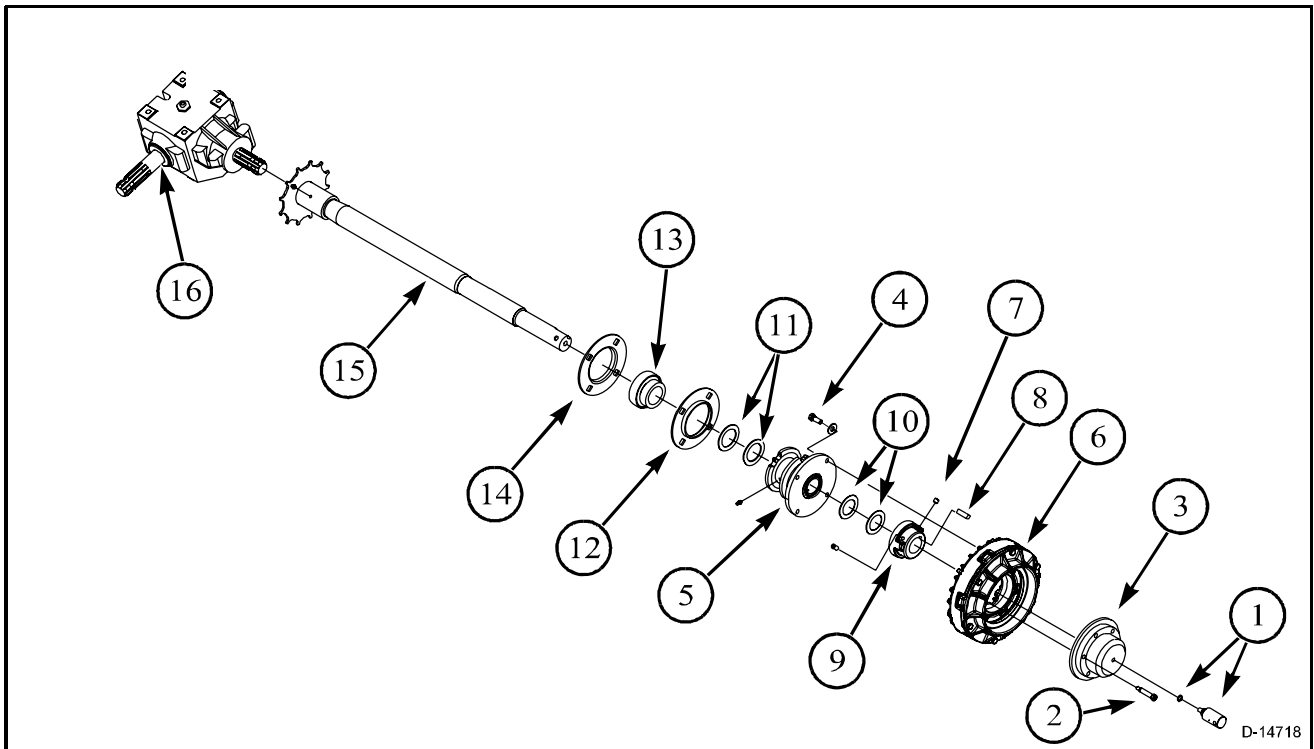

FIG. 23

Remove the rotary union and brass washer (1).

NOTE: The rotary union threads are left-hand. Remove the rotary union from the cylinder before disconnecting the hose from the rotary union.

Remove the six shoulder screws (2). Remove the hydraulic cylinder (3).

Remove the four cap screws (4) from the back side of the sprocket assembly (5).

Remove the clutch assembly (6) as a whole unit.

Remove the set screw (7), and key (8), in the clutch hub collar (9).

Remove the two outside bushings (10).

Remove the upper drive roll chain (not shown in image) and the starting roll chain (also not shown in image).

Remove the sprocket assembly.

Remove the two narrow rim machinery bushings (11).

Remove the outside flange (12).

Remove the spherical bearing (13).

Remove the inside flange (14).

Disconnect the shaft (15) from the gearbox (16).

Installation

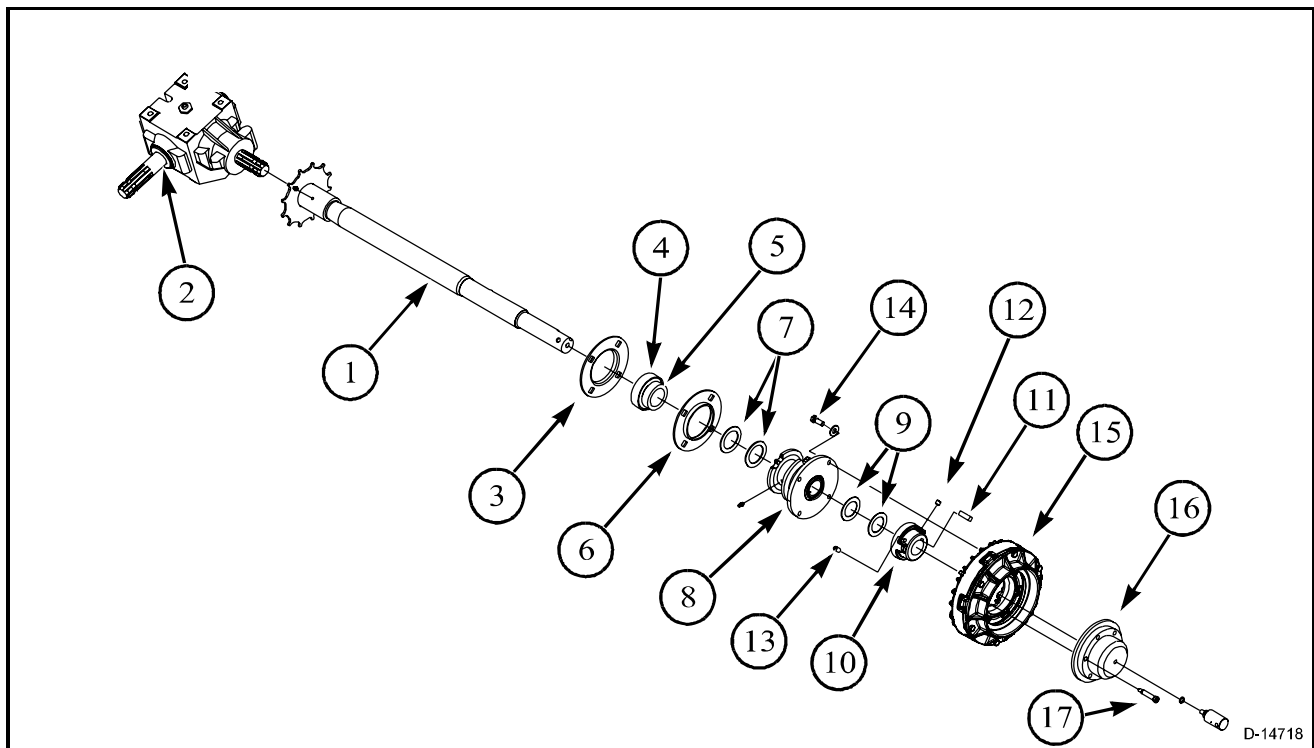

FIG. 24

FIG. 24: Install the shaft (1) onto the gearbox (2). The shaft must slip fit onto the gearbox after tightening

Install the inside bearing flange (3) followed by the spherical bearing (4) and lock collar (5). Install the outer bearing flange (6). The shaft must slip fit into the gearbox and rotate freely after tightening the bearing hardware.

Install the two machinery bushings (7).

Install the sprocket assembly (8) onto the shaft.

Install the two narrow rim machinery bushings (9) onto the shaft.

Install the clutch hub (10) on the shaft. Install the key (11) and set screw (12). The set screw (13) must center in the hole on the shaft. Tighten the set screw to 31 Nm (22 lbf ft).

NOTE: The hub is included in the clutch assembly.

Set bearing lock collar to maintain 0.25 to 0.38 mm (0.010 to 0.015 in) axial play in the sprocket assembly.

Install the four cap screws (14) to the clutch assembly (15) from the inside of the sprocket assembly.

Install the hydraulic cylinder (16) with the six hex socket head shoulder screws (17) with loctite 243® thread locker. Tighten the shoulder screws to 24 Nm (17 lbf ft).

Drive System

FIG. 25: Install the upper drive roll chain (1) and the starting roll chain (2). Make sure the tension on the chain is correct.

Install the rotary union (3) with the hydraulic hose still attached (4).

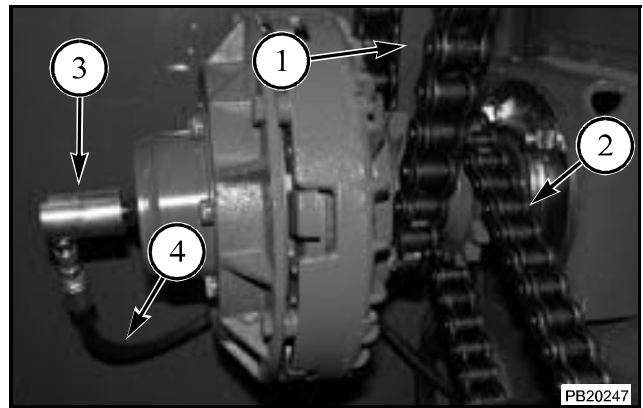

FIG. 25

STARTING ROLL AND LOWER DRIVE ROLL

In order to remove the starting roll or lower drive roll, the same procedures must be followed. The lower drive roll can not be removed unless the starting roll is removed first. Both rollers have the same removal and installation procedures.

Removal

Release the tension on the forming belts before doing the following:

FIG. 26: To release the forming belt tension:

Disengage the PTO.

Stop the tractor engine, and take the key with you.

Turn the knob on the pressure release valve (1) counterclockwise.

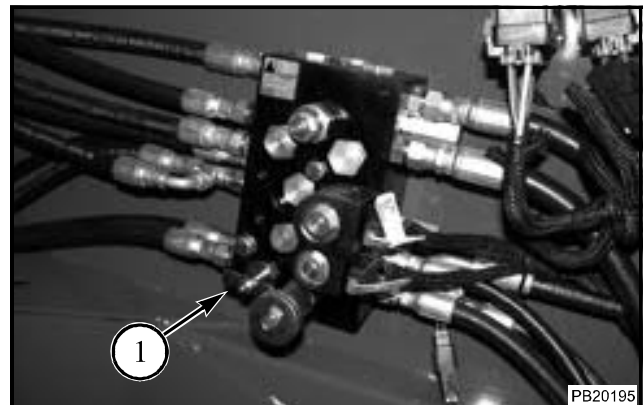

FIG. 26

FIG. 27: Loosen the sprocket idler (1). Remove the left-hand starting roll chain (2). Remove the starting roll sprocket (3).

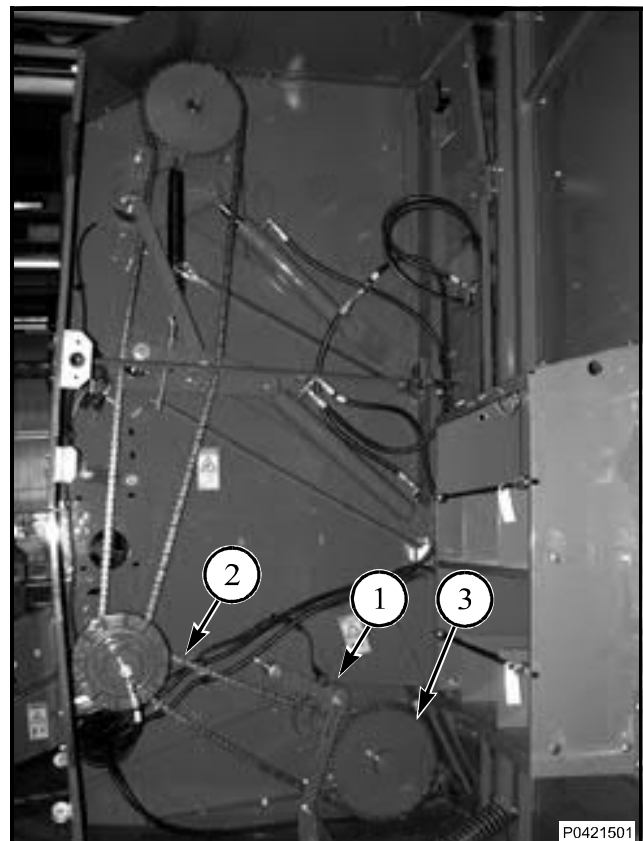

FIG. 27

Drive System

FIG. 28: Loosen the tensioner sprocket (1).
Remove the feeder chain (2) and sprocket.

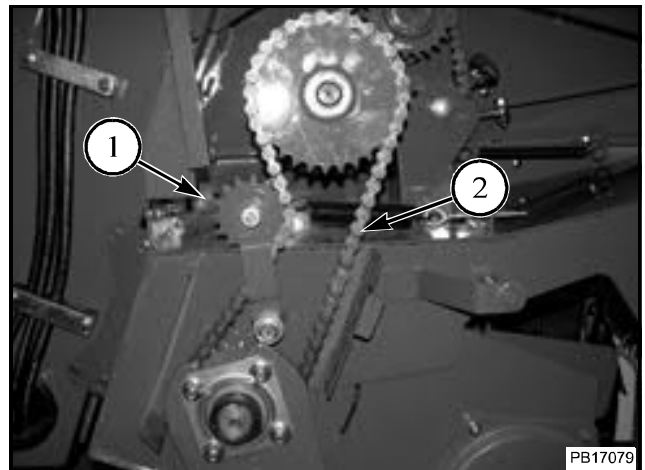

FIG. 28

FIG. 29: Loosen the tensioner sprocket bolt (1).

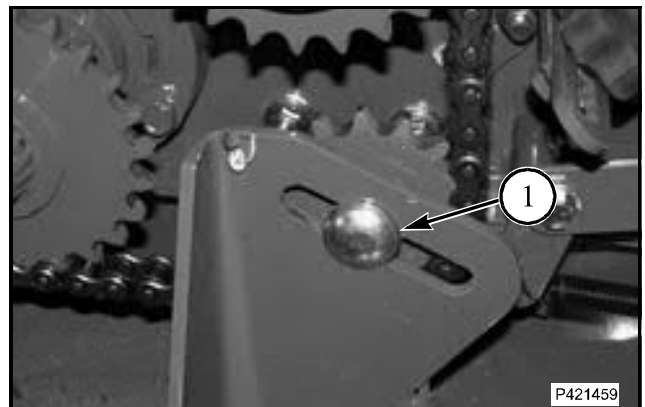

FIG. 29

FIG. 30: Remove the lower drive roll chain (1). Remove
the feeder clutch (2).
Remove the sprocket (3).

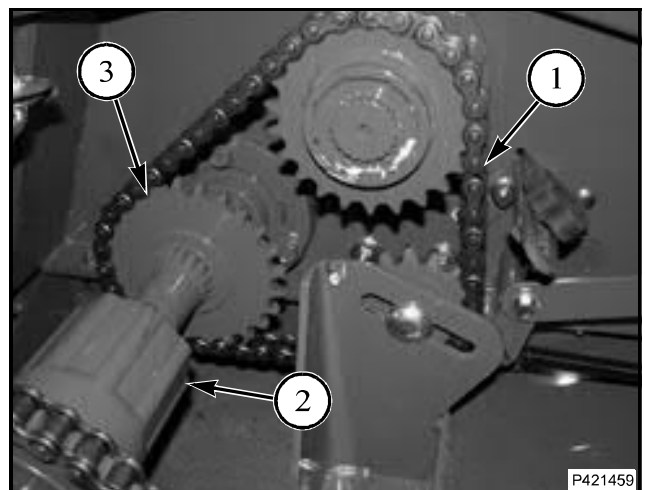

FIG. 30

Thank you so much for reading.
Please click the “Buy Now!”
button below to download the
complete manual.



After you pay.

You can download the most
perfect and complete manual in
the world immediately.

Our support email:

ebooklibonline@outlook.com