

Massey Ferguson®

8936
Planter

SERVICE MANUAL 4283479M2

CONTENTS

GENERAL INFORMATION	01
ROW UNIT	02
DRIVE SYSTEMS	03
AIR SYSTEM	04
HYDRAULICS	05
ELECTRICAL	06
TROUBLESHOOTING	07
ADJUSTMENTS	08

DRIVE CHAINS AND SPROCKETS

ROLLER CHAINS

Lubrication

Use a good grade of clean petroleum based engine oil to lubricate roller chains.

Detergent oils are not required. Oils with anti-foam, anti-rust, or film-strength improving additives can be good.

NOTE: Heavy oils and greases are too stiff to enter the chain joints and must not be used.

Indication of Good Roller Chain Lubrication

Inspect the connector link pins after removal.

- A properly lubricated roller chain will have a high luster polish and will not be discolored.
- A poorly lubricated roller chain will have a reddish-brown oxide in the joints. The connector link pins will be discolored, roughened, or grooved.

Roller Chain Lubrication

A properly lubricated roller chain will last many times longer than the same roller chain which is poorly lubricated and maintained.

Lubrication of the chain pins and inner link bushing surfaces which turn with each other while the chain is under full load is most important. Lubrication is also required between the chain rollers and inner link bushing surfaces.

Apply oil to the upper edges of the chain link on the slack side of the chain right before the chain engages a sprocket.

If oil is applied only to the chain rollers, the oil cannot reach the chain link (side) plate pins and bushings, and will not reduce chain wear and elongation.

The elongation of roller chains results from wear between the pins and bushings only. Roller wear does not cause elongation of roller chains.

Under severe conditions, it is recommended that the chain be removed every 50 hours of operation and cleaned and lubricated. Remove the chains for cleaning and lubrication at the end of every season.

Roller Chain Elongation

Roller chain wear occurs on the inside of the chain in the load bearing areas. The load bearing areas are between the outer link pins and the inner link bushing surfaces. This wear causes chain elongation. This wear is not seen on the outside of the chain and cannot be measured with the chain under tension.

To measure chain elongation:

- Clean the chain.
- Select a section of chain about 300 mm (1 ft) long.
- Push the selected section of chain tightly together and measure the distance between the link pins.
- Pull on the same selected section of chain and measure the distance between the same link pins.
- If the free play or elongation is more than 3 mm per 300 mm (1/8 in per ft), the chain is worn out and must be replaced.

Wear of this measurement or more indicates that the hardened surfaces on the link pins are worn through. This makes the chain weaker and makes frequent adjustment necessary.

A gradual increase in chain slack is the result of normal chain wear.

A sudden increase in chain slack can indicate:

- Not enough lubrication.
- Failure of the lubricant.
- Loose bearing mounting hardware or a failed drive.
- Loose sprockets or sprocket bearings.

Drive Chains and Sprockets

Installation

NOTE: Do not install a new chain on worn sprockets. Several hours of operation under such conditions will do more damage to a new chain than many hours of normal use.

Never insert a new link in a chain that has been elongated by wear. The pitch of the new link will be shorter than the pitch of the original links. The shock each time the new link engages a sprocket will soon destroy the chain.

Do not install a worn chain on new sprockets. A worn chain will ride high on the outer tips of the sprocket teeth causing rapid wear of the new sprockets.

FIG. 1: Install the chain onto the sprockets with the chain ends on a sprocket. Make sure the chain is routed correctly.

Install the connecting link pins.

When using spring clip connectors (1), always install the spring clip with the open end of the clip trailing the direction of chain travel (2). This will prevent removal or loss of the spring clip by accident.

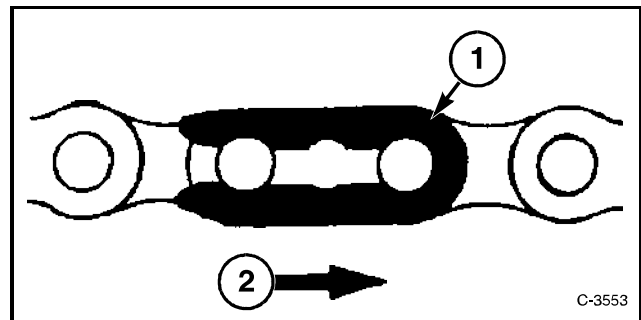

FIG. 1

SPROCKETS

Sprocket Wear

A worn roller chain must never be used with new sprockets since the chain no longer fits the sprocket teeth properly. A worn roller chain rides high on the outer tips of the sprocket teeth, causing rapid wear on the outer tips of the sprocket teeth.

Chain tension that is not correct can cause wear that is not normal on the outer tips of the sprocket teeth.

Not enough lubrication can cause sprocket tooth wear that is not normal.

Worn sprockets must never be used with new roller chain. Worn roller chain must never be used with new sprockets.

Sprocket Alignment

Periodically check the alignment of all sprockets. Correct any problems that may be found. Sprocket alignment that is not correct is seen by wear on the sides of the sprocket teeth and on the inside of the chain links.

Correct sprocket alignment is important for long roller chain service life.

Make sure that:

The sprockets must be in line. Use a straightedge to check the sprockets.

Sprockets that are not in line will result in loading that is not even across the width of the chain and can cause early chain failure.

SEED METER DRIVE

General Information

FIG. 2: A spring-loaded idler assembly maintains the seed meter drive chain tension.

The chain must be aligned between the (1), idler pulleys (2), and clutch sprocket assembly (3). Shift the drive sprocket position on the drive shaft to attain correct alignment. Add shims at mounting bolts to align if necessary.

Regularly inspect chains and idlers for excessive wear. Replace as necessary.

Each seed meter is turned by a 20 tooth bearing assembly sprocket (1) on the drive shaft.

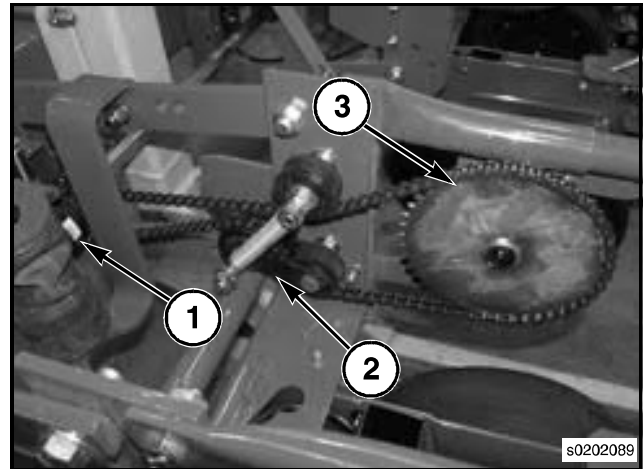

FIG. 2

Removal

FIG. 3: Push down on the idler pulley to relieve tension on the chain.

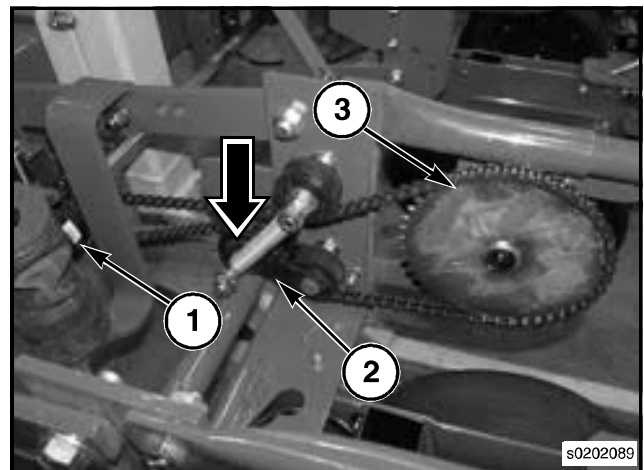

FIG. 3

FIG. 4: Remove the 116 link chain (1).
Inspect chain. Replace chain as required.
The chain has a spring clip to easily disconnect.

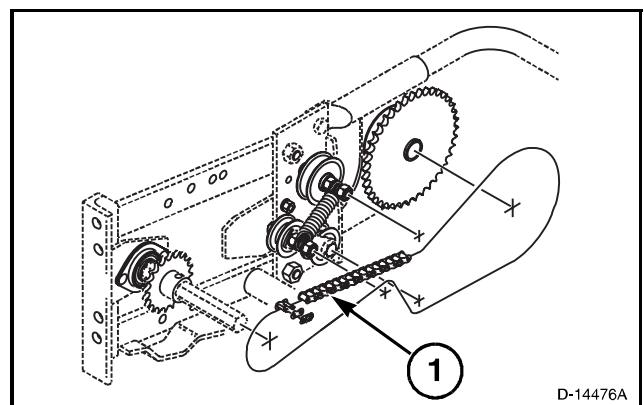

FIG. 4

Drive Chains and Sprockets

Installation

Lubricate idler with grease.

Insert chain onto sprockets properly and through the idler assembly.

Push down on the idler pulley and slip chain over the idler pulley with the chain bearing under the other two idler pulleys.

Release idler pulley to increase tension.

IDLER PULLEY

Removal

FIG. 5: Remove the center lock nuts (1) then remove the spring (2).

Slide the top pulley (3), washers (4), and short (5) and long spacer (6) off the cap screw (7). Replace any components that are damaged or worn.

Remove center lock nuts (8).

Remove cap screws (9) and disassemble idler pulley assembly. Replace any components that are damaged or worn.

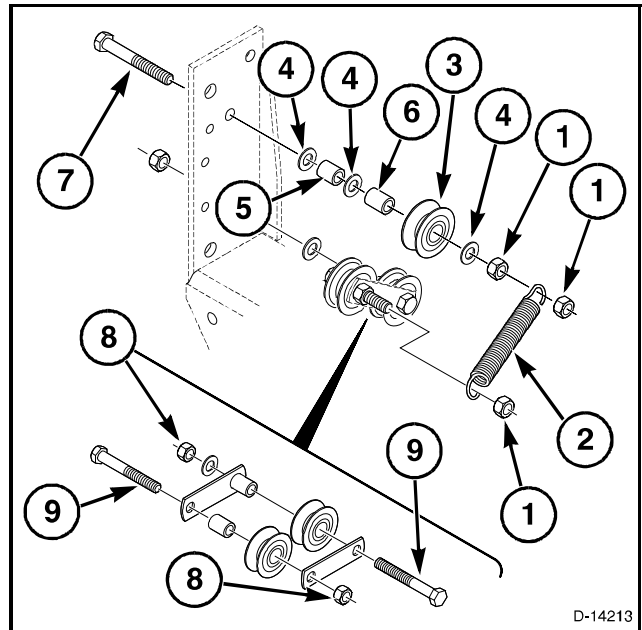

FIG. 5

Installation

FIG. 6: Grease idler pulleys.

Insert cap screw (1) through tightener strap (2), idler (3), spacer (4), chain tightener (5), washer (6), and center lock nut (7). Do not tighten center lock nut. The cap screw must turn freely after assembled.

Install idler pulley and insert cap screw (8) through other half of assemble. When tightening the center lock nut, hold the inner center lock nut, not the cap screw, so that the center lock nuts are tight, but the idler pulley assembly is able to pivot.

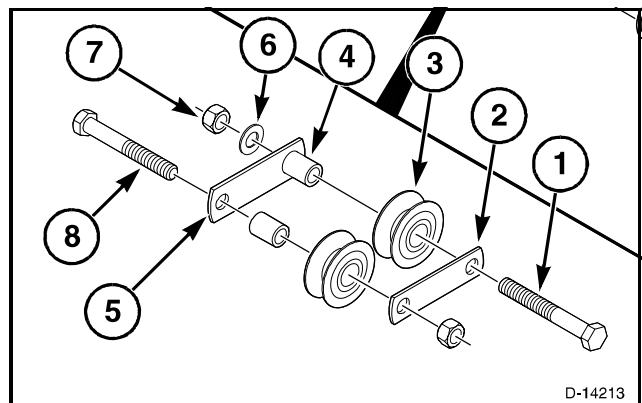

FIG. 6

Drive Chains and Sprockets

FIG. 7: Install idler pulley onto bracket and tighten the center lock nut (1).

Slide the cap screw (2) through the bracket, the washer (3), spacer (4), washer (5), spacer (6), idler (7), washer (8), and tighten on the center lock nut (9). Do not over tighten.

Install spring (10) and the center lock nuts (11).

Install the chain.

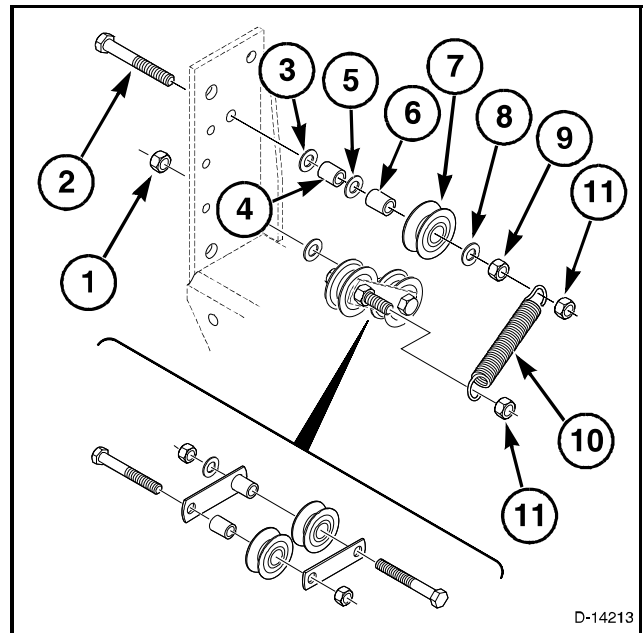

FIG. 7

D-14213

Drive Chains and Sprockets

SPROCKET ASSEMBLY

Removal

FIG. 8: Remove roller chain (1) from sprocket assembly (2).

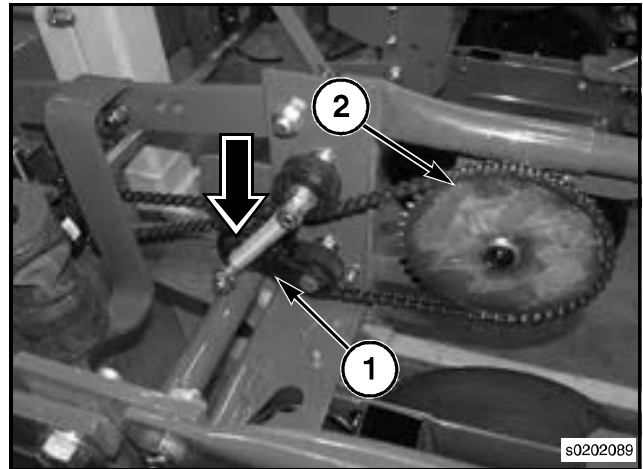

FIG. 8

FIG. 9: Remove the three flange screws (1) from sprocket assembly (2).

Remove the snap ring (3).

Remove the handle ring (4) and second snap ring (5).

Remove the sprocket assembly.

Replace sprocket assembly damaged or worn.

NOTE: The sprocket assembly cannot be serviced separately.

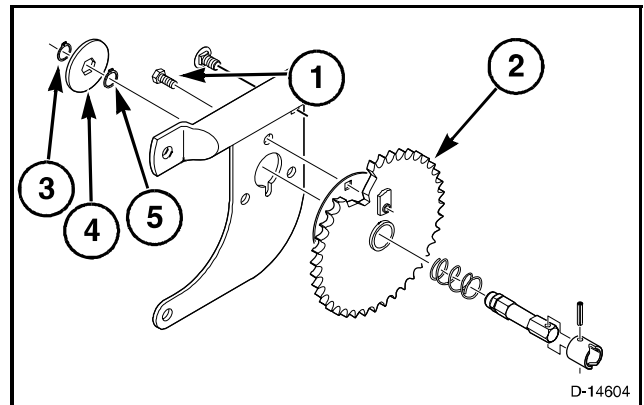

FIG. 9

Installation

FIG. 10: Insert the sprocket assembly (1).

Attach the snap ring (2) onto the shaft.

Install the handle ring (3) and the snap ring (4).

Insert the three flange screws (5) into the sprocket assembly and tighten.

Install roller chain.

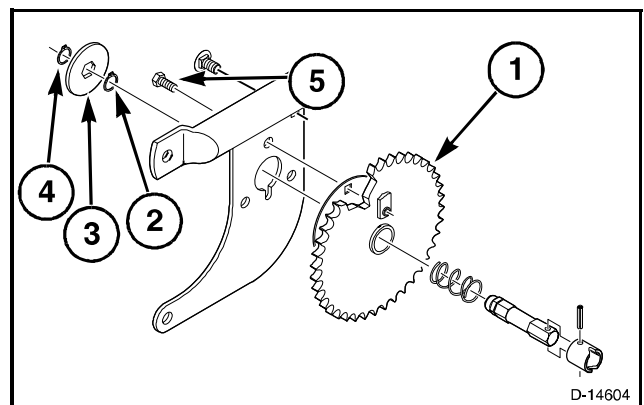

FIG. 10

PNEUMATIC CLUTCH ASSEMBLY

SWATH CONTROL - GENERAL INFORMATION

IMPORTANT: For maintenance, use the spray(s) included in the air clutch kit rather than a penetrating oil. Any solvents used will work only temporarily and then dry out the clutch. Heavier oils may gum up the clutches.

Air Clutches

FIG. 11:

The air clutches (1) come from the factory pre-lubricated. The clutches do not need to be lubricated upon installation.

Every 75 to 100 hours of operation, or as needed, lubricate the air clutch with an all-purpose silicone lubricant.

To do this:

1. Remove the pan-head screw (2) from the clutch housing.
2. Insert a spray can nozzle.
3. Spray for several seconds.
4. Replace the screw or plug.
5. Complete this step to all clutch housings.
6. Rotate the clutches by engaging the seed shaft to make sure there is complete coverage.

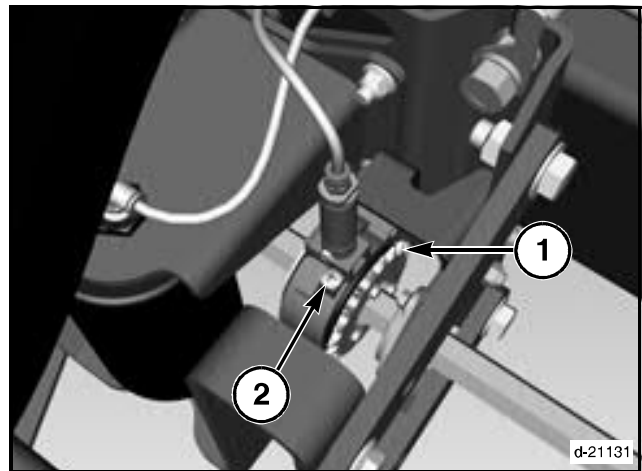

FIG. 11

End of Season

FIG. 12: For end-of-season maintenance, remove any foreign matter inside the clutch.

To do this, remove the air hose (1) from the air cylinder (2) by pressing down on the black collar (3) and then pulling the air hose.

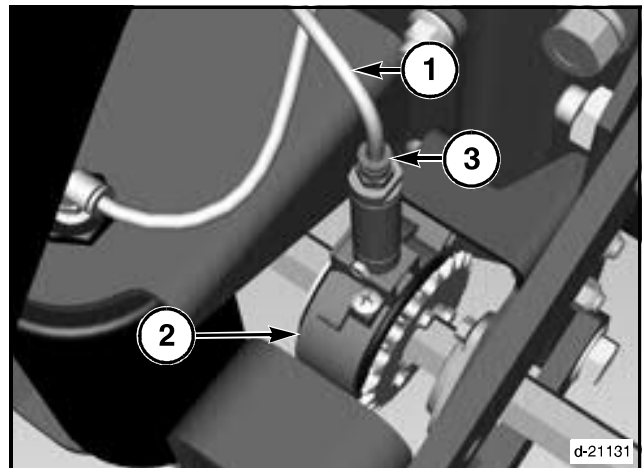

FIG. 12

Pneumatic Clutch Assembly

FIG. 13: Remove the air cylinder using a 5/8 wrench or adjustable wrench.



FIG. 13

FIG. 14: Remove the oil plug (1).

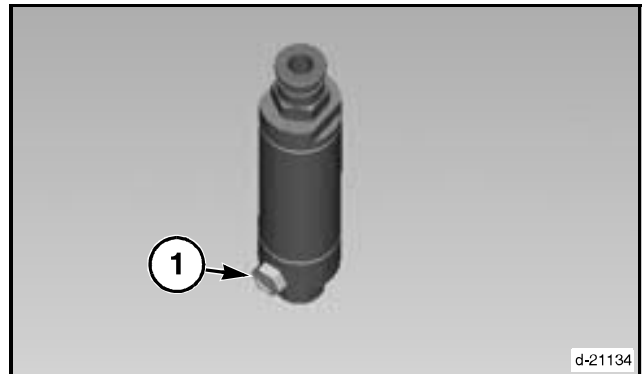

FIG. 14

FIG. 15: Remove the bolt (1) that secures the air clutch (2) to the frame.

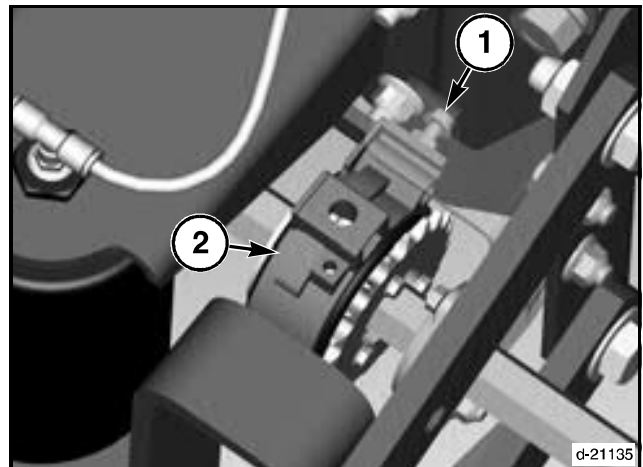

FIG. 15

Pneumatic Clutch Assembly

7. Rotate the clutch downward.



WARNING: Wear Safety glasses to prevent personal injury.

Use low pressure air through a nozzle to blow out any dust build up.

8. Use an all purpose silicone lubricant to clean and protect the clutch components.

Spray for several seconds to make sure there is complete coverage of the lubricant on the clutch hubs.

Rotate the shaft to help the lubricant cover the necessary surfaces inside the air clutch.

The goal is to free the internal components of built-up and to protect the components from oxidation.

NOTE: Even though the hubs are oil impregnated, failure to complete the steps above will enable chemical/fertilizer spray, dust, dirt, mud, grease, water, and other contaminates to build up. These build ups can impact the performance of the clutch.

Disassemble the clutches and thoroughly clean after 2 to 3 years of use, depending on the level of use, general maintenance, and field conditions.

After removing from storage and before planting, spray an all purpose silicone lubricant through the oil access port to re-lube the clutches. Spray for several seconds in each clutch.

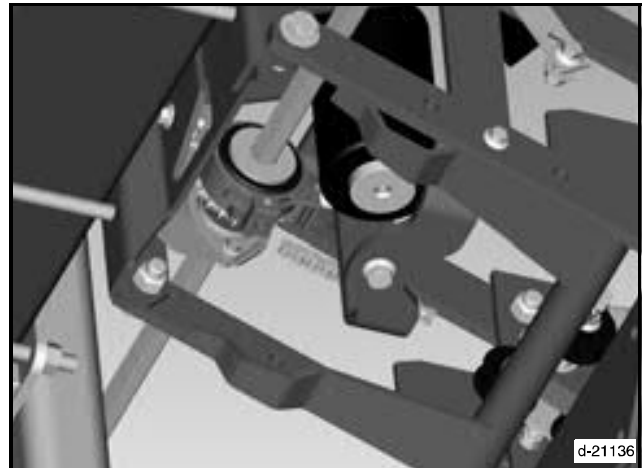

FIG. 16

General Maintenance of Other System Components

Air Cylinder Maintenance

FIG. 17: Complete the following maintenance annually (or as needed):

1. Oil the air cylinder as needed and at the beginning of every season.
2. Remove the air hose to the air clutch.
3. Place one drop of supplied oil in each air cylinder.
4. Replace the air hoses.
5. Activate the air cylinder to make sure the oil works its way to the cylinder plunger.

NOTE: Placing oil in the air cylinder will not lubricate the clutch components. Do not spray penetrating fluid or silicone spray in the air cylinder. This will damage the cylinder valve seal.

A small packet of oil is supplied with each complete air clutch kit purchase.

More oil can be purchased or you can use an alternative.

For Buna N seals, the recommended oils such as medium to heavy inhibited, no-detergent hydraulic and general purpose oil. See the Recommended Lubricants table.



FIG. 17

Pneumatic Clutch Assembly

Oil as needed if the cylinder performance decreases, slows or will not extend/retract. Environmental conditions may demand an increase in lubrication and maintenance.

Symptoms of this will be slow reaction time of the air clutch, a clutch that will not engage or a clutch that will not release due to the state of the cylinder plunger.

FIG. 18: This can be inspected by unscrewing the air cylinder from the clutch housing.

NOTE: Do not allow dirt and debris to enter the air clutch after the air cylinder is removed. When replacing the cylinder, use caution as cross threading can occur.

IMPORTANT: Do not use penetrating fluid or silicone spray inside the air cylinder as this will damage the seal.



FIG. 18

FIG. 19: Look for signs of corrosion and/or build-up around the plunger at the tip of the cylinder bushing.

Wipe clean with a rag.

Place one drop of oil in the air cylinder. Then activate the cylinder several times to allow the oil to work its way into the bushing for lubrication. The air cylinder may need to be replaced if the plunger will not activate.



FIG. 19

End of Season

FIG. 20: Place one drop of oil or Magna Lube in the air cylinder. To do this:

1. Remove the air hose from the cylinder.
2. Place one drop of oil in the cylinder.
3. Install the air hose.
4. Activate the cylinder several times.

NOTE: Warranty does not support the use of an automatic oiler for air cylinders. An automatic oiler may not deliver sufficient oil to the air cylinders. It may also harm the valves in the valve module boxes if the oil supply is stopped and the seals dry out. This will void the warranty.

Compressor Maintenance

The compressor is permanently lubricated. Do not lubricate.

Daily

FIG. 21: Periodically check for moisture build up in the air compressor manifold and airlines. To do this:

1. Close the ball valve on the compressor assembly after the compressor has operated for some time.
2. Remove the air hose from the ball valve connector.
3. Open the ball valve. This will release and purge the assembly of moisture allowing the compressor to operate more efficiently and extend the life of the pressure switch. This will provide a more accurate reading for the switch performance.



CAUTION: Stand back as the air line will be under pressure!

End of Season

wait for eng electrical releases

At the end of the season:

1. Disconnect the wire harness from the battery and the compressor.
2. Inspect the harness, all electrical connections, and fittings for damage.
3. Clean and tighten as necessary.
4. Replace the air filter element.
5. Clean dust and dirt from the cooling fins and housing.
6. Store the compressor in a dry environment.

For more information regarding repairs and maintenance, see the compressor manufacturer's user manual included in the compressor assembly.



FIG. 20

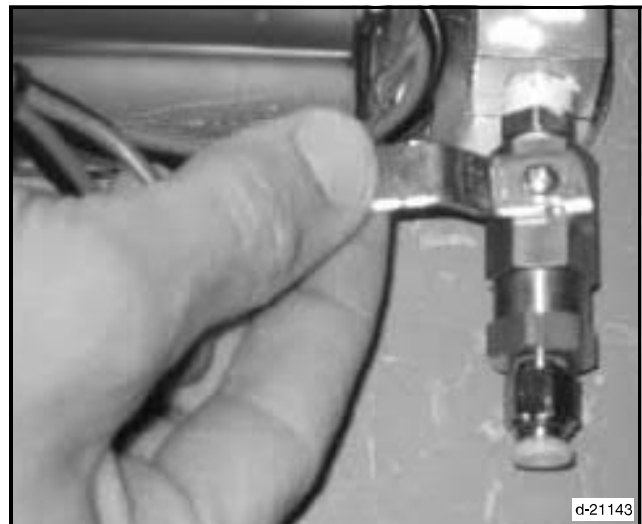

FIG. 21

Pneumatic Clutch Assembly

Tip: At the end of each season inspect the electrical fittings. Clean and replace if necessary. Dielectric grease can be applied to the exposed terminals to make sure a trouble-free power connection for the air compressor.



WARNING: Never touch the air compressor or leader hose coming from the compressor with bare hands while the compressor is in operation or shortly after. The compressor and leader hose will be HOT during use and shortly after.

Tank and Air Hose Maintenance

Daily

FIG. 22: Periodically check for moisture build up in the air tanks and air lines. To do this:

1. Open the drain cocks on the air tanks.
The tanks must be mounted vertically so the drains are at the bottom.
2. Drain more frequently if necessary.



CAUTION: Stand back as the air line will be under pressure!

End of Season

At the end of the season, detach all the air hoses from the air clutches and purge any moisture from the air lines. To do this:

1. Drain the air tank(s) and then close the drain.
2. Allow the compressor to pump to normal operating pressure.
3. Detach all air hoses at the air cylinders and secure to the planter with hoses aimed downward.
4. Keep a safe distance away from the hose ends before the next step: a whipping action may occur due to the high pressure.
5. Energize the valves until all moisture is released:
 - Using a manual control box - turn the master plant mode switch to All Stop.
 - Using a GPS section controller - turn all planter sections off.
6. Place one drop of supplied oil or Magna Lube in the cylinder for storage.
7. Clean and inspect hose ends. Make new straight cuts as necessary.
8. Connect the air hoses to the cylinders.
9. Allow the compressor to pump to normal operating pressure again.



FIG. 22

Pneumatic Clutch Assembly

10. Energize the valves again by turning all sections off.
11. Check for air leaks from loose or damaged fittings.
 - Using a small brush, apply soapy water to the air hose fittings (1) and the air cylinder (2).
 - A constant bubbling at the fitting (3) or muffler may indicate an air leak.
12. Tighten the hose and replace the fittings or cylinder as necessary.

NOTE: Only the air cylinder is pressurized, not the clutch.

NOTE: An air dryer or water separator may be added to the air system if required.

Valve Maintenance

The air valves do not require lubrication.

- Do not lubricate the air valves.
- The valves are lubricated for life.

IMPORTANT: Introducing a lubricant may cause damage to the seals, attract dust to the valve box, and will void the warranty.

Do not use an automatic oiler for the air cylinders. This will not deliver oil to the air cylinders and can harm the valves in the valve module boxes which will void the warranty.

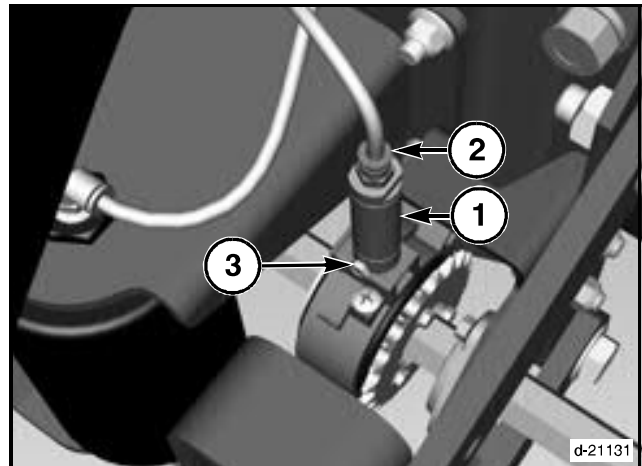

FIG. 23

Recommended Lubricants

Maintenance Item	Recommended Lubricants
Air clutch maintenance	- Spray-on All Purpose Silicone Lube - Liquid Wrench Silicone Spray
Air clutch service	- WD40 Aerosol - Liquid Wrench Lubricating Oil - Crown All 4 - PB Blaster
Air Cylinder	- Bimba Lube - Light-weight hydraulic oil without additives (10W) - Automatic transmission fluid (Type F ATF or Dexron II ATF) - Power steering fluid
Air cylinder storage 60 days +	- Magna Lube G
Compressor electrical connection maintenance	- Permatex Dielectric Tune-Up Grease - Loctite Dielectric Grease

Pneumatic Clutch Assembly

REPAIR

General Information

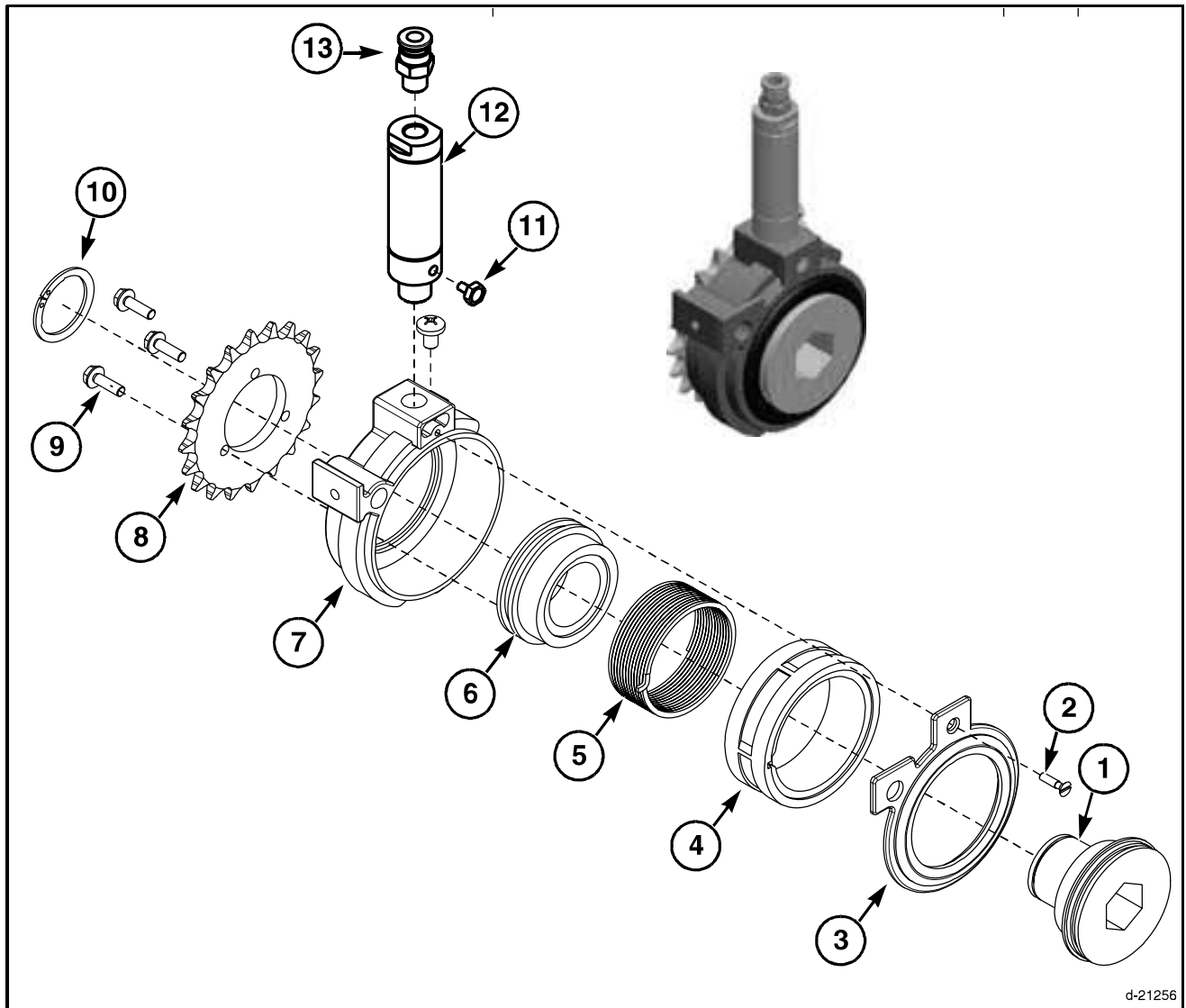

d-21256

FIG. 24

FIG. 24: Exploded view of the pneumatic clutch.

- | | |
|-------------------------|-------------------|
| (1) Pin Hub | (11) Screw |
| (2) Screw | (12) Air Cylinder |
| (3) Clutch | (13) Fitting |
| (4) Stop Collar | |
| (5) Torsion Spring | |
| (6) Slip Hub | |
| (7) Clutch Housing | |
| (8) Sprocket - 20 tooth | |
| (9) Bolt | |
| (10) Retaining Ring | |

Thank you so much for reading.
Please click the “Buy Now!”
button below to download the
complete manual.



After you pay.

You can download the most
perfect and complete manual in
the world immediately.

Our support email:

ebooklibonline@outlook.com