



MASSEY FERGUSON

MF 4600

Series Tractors

Models: 4608 / 4609 / 4610

SERVICE MANUAL

FROM MASSEY FERGUSON

4608 / 4609 / 4610 Service Manual

1 Introduction	1-1
1.1 Introduction	1-3
1.1.1 The service manual	1-3
1.1.2 Replacement parts	1-3
1.1.3 Units of measurement	1-3
1.1.4 Machine identification	1-3
1.1.5 Serial number plate	1-4
1.1.6 Engine identification	1-4
1.1.7 Chassis number	1-5
1.2 Specifications	1-6
1.2.1 Engine specifications	1-6
1.2.2 Electrical specifications	1-6
1.2.3 Transmission specifications	1-7
1.2.4 Power takeoff specifications	1-7
1.2.5 Front axle specifications	1-7
1.2.6 Rear axle specifications	1-8
1.2.7 Brake specifications	1-8
1.2.8 Hydraulic specifications	1-8
1.2.9 Fuel specifications	1-8
1.2.10 Operating slope angle	1-9
1.2.11 Lubrication specifications	1-9
1.2.12 Capacities	1-10
1.2.13 Maximum load capacity	1-10
1.2.14 Wheel bolt torque chart	1-11
1.2.15 Tire inflation pressures	1-12
1.3 General dimensions	1-14
1.3.1 Platform tractor dimensions	1-14
1.3.2 Cab tractor dimensions	1-15
1.4 Lubrication / fill points	1-17
1.4.1 Lubrication and maintenance chart	1-17
1.4.2 Initial lubrication and maintenance chart	1-18
1.4.3 Lubrication fill and drain locations	1-19
1.5 General precautions for disassembly and installation	1-20
1.5.1 Precautions for disassembling and installing	1-20
1.5.2 Precautions when installing according to standards parts	1-20
1.6 Tightening torque chart	1-23
1.7 Conversion table	1-25
2 Safety	2-1
2.1 Introduction	2-3
2.1.1 Safety alert symbol	2-3
2.1.2 Informational messages	2-3
2.1.3 Safety messages	2-3
2.1.4 Safety signs	2-4
2.2 Operation	2-11
2.2.1 Prepare for operation	2-11
2.2.2 Roll over protective structure	2-11
2.2.3 General information	2-11
2.2.4 Personal protective equipment	2-15
2.2.5 Seat instruction	2-15
2.2.6 Shield and guards	2-15

2.2.7	Power takeoff safety	2-16
2.2.8	Exhaust warning	2-17
2.2.9	Flying debris	2-17
2.3	Travel on public roads	2-18
2.4	Maintenance	2-20
2.4.1	General maintenance information	2-20
2.4.2	Fire prevention and first aid	2-21
2.4.3	High pressure leaks	2-22
2.4.4	Engine safety	2-23
2.4.5	Fuel safety	2-24
2.4.6	Battery safety	2-25
2.4.7	Tire safety	2-25
2.4.8	Replacement parts	2-26
3	Engine	3-1
3.1	Component access	3-3
3.1.1	Opening the engine cover	3-3
3.2	Radiator	3-4
3.2.1	Removing the radiator	3-4
3.3	Removing the engine	3-6
3.4	Installing the engine	3-10
3.5	Fuel tank	3-11
3.5.1	Removing the fuel tank	3-11
3.6	Electronic diagnostic tool	3-14
3.6.1	Engine service tool software license	3-14
3.6.2	Connecting the electronic diagnostic tool	3-14
3.7	Engine service manual	3-15
3.7.1	Insert the engine service manual here	3-15
4	Power train	4-1
4.1	Separating the engine from the front transmission	4-3
4.2	Separating the front and mid-transmission housings	4-9
4.3	Separating the mid and rear transmission housings	4-13
4.4	Separating the rear axle from the rear transmission case	4-17
4.5	Attaching the rear axle to the rear transmission case	4-19
4.6	Power shuttle transmission	4-20
4.7	Power train	4-23
4.8	Gear ratios	4-26
4.9	Shuttle clutch	4-28
4.9.1	Assembling precautions for power shuttle	4-29
4.10	Clutch pack	4-30
4.10.1	Reverse clutch pack components	4-30
4.10.2	Disassembling the reverse clutch	4-31
4.11	Input gears	4-32
4.11.1	Removing the input gear	4-32
4.11.2	Disassembling the input gear	4-32
4.11.3	Assembling the input gears	4-33
4.11.4	Disassembling the rear and mid-transmission housing	4-34
4.11.5	Input gears	4-36
4.12	Transmission main change gears	4-40
4.12.1	Assembling precautions for main gear system	4-41
4.12.2	Main shift lever	4-42
4.12.3	Assembling precautions for the main shift lever	4-43
4.12.4	Disassembling the high-low gear	4-44

4.13 Creeper gear	4-45
4.13.1 Creeper gear components	4-45
4.13.2 Disassembling the creeper gear	4-45
4.13.3 Assembling the creeper gear	4-49
4.14 Transmission range change gears	4-53
4.14.1 Range gear shift	4-53
4.14.2 Installing the range gear shift	4-54
4.14.3 Range shift linkage	4-55
4.14.4 Independent power takeoff	4-56
4.14.5 Power takeoff clutch	4-57
4.14.6 Assembling power takeoff precautions	4-58
4.14.7 Four-wheel drive gears, if equipped	4-58
4.14.8 Assembling four-wheel drive, if equipped	4-59
4.14.9 Four-wheel drive gear system	4-60
4.14.10 Two wheel-drive gear system	4-61
4.14.11 Power takeoff speed	4-61
4.14.12 Power takeoff lever	4-63
4.14.13 Power takeoff link check system	4-63
4.14.14 Low profile lever	4-63
5 Cab and platform	5-1
5.1 Platform	5-3
5.1.1 Removing the platform	5-3
5.1.2 Removing the floor mat and steps	5-11
5.1.3 Installing the floor mats and steps	5-12
5.2 Cab	5-13
5.2.1 Removing the cab	5-13
5.2.2 Installing the cab	5-19
5.2.3 Removing the cab roof	5-20
5.2.4 Installing the cab roof	5-20
5.2.5 Opening the roof	5-21
5.2.6 Removing the door	5-22
5.2.7 Installing the door	5-22
5.2.8 Adjusting the door tilt	5-24
5.2.9 Adjusting the opening angles of the door	5-24
5.2.10 Installing the door lock	5-25
5.2.11 Relay position	5-26
5.2.12 Cab lamp	5-27
5.2.13 Wiper and flood light switches	5-27
5.2.14 Air conditioner control panel	5-28
5.2.15 Air conditioning dual pressure switch	5-28
5.2.16 Cab wire harness	5-29
5.2.17 Installing the speaker system	5-29
5.2.18 Installing the antenna assembly	5-31
5.3 Seat	5-34
5.3.1 Removing the seat	5-34
5.3.2 Installing the seat	5-35
5.4 Roll over protective structure	5-36
5.4.1 Removing the roll over protective structure	5-36
5.4.2 Installing the roll over protective structure	5-36
5.5 Steering column	5-37
5.5.1 Removing the steering column	5-37
5.5.2 Installing the steering column	5-37
5.6 Steering wheel	5-38
5.6.1 Removing the steering wheel	5-38
5.6.2 Installing the steering wheel	5-38

5.7 Mirrors	5-39
5.7.1 Adjusting the mirror arm assembly	5-39
5.8 Air conditioning system	5-41
5.8.1 Air conditioner outline	5-41
5.8.2 Air conditioner system specifications	5-41
5.8.3 Drain hoses	5-42
5.8.4 Air conditioner hoses	5-43
5.8.5 Heater hose	5-45
5.8.6 Installing the insulator	5-48
5.8.7 Compressor	5-49
5.8.8 Condenser	5-50
5.8.9 Receiver dryer	5-51
5.8.10 Air conditioner unit	5-51
5.8.11 Expansion valve	5-52
5.8.12 Air conditioning dual pressure switch	5-52
5.8.13 Thermostat	5-53
5.8.14 Air conditioner operation	5-53
5.8.15 Air conditioner inspection and maintenance	5-53
5.8.16 Refrigerant amount check	5-54
5.8.17 Air conditioner compressor belt	5-55
5.8.18 Adjusting the air conditioner compressor belt	5-56
5.8.19 Servicing the condenser	5-56
5.8.20 Changing the air conditioner filter	5-58
5.8.21 Maintenance	5-60
5.8.22 Removing the air conditioner compressor	5-60
5.8.23 Installing the air conditioner compressor	5-61
5.8.24 Removing the condenser	5-62
5.8.25 Installing the condenser	5-63
5.8.26 Removing the receiver dryer	5-63
5.8.27 Installing the receiver dryer	5-64
5.8.28 Removing the air conditioner unit	5-64
5.8.29 Air conditioner control lever cable	5-65
5.8.30 Shutter for inside/outside air control	5-65
5.8.31 Assembling the air conditioner and relative components	5-66
5.8.32 Safety precautions when charging the refrigerant	5-67
5.8.33 Connecting the service gauge manifold	5-69
5.8.34 Evacuating the air conditioning system	5-69
5.8.35 Performing airtight check 1	5-70
5.8.36 Performing the airtight check 2	5-70
5.8.37 Charging from the high pressure side	5-71
5.8.38 Charging from the low pressure side	5-72
5.8.39 Detaching the service gauge manifold	5-74
5.9 Troubleshooting the air conditioner system	5-75
6 Frame and axles	6-1
6.1 Hydrostatic steering	6-3
6.1.1 Construction	6-3
6.1.2 Major components	6-4
6.1.3 Orbit roll disassembly	6-4
6.1.4 Disassembling the gerotor side	6-5
6.1.5 Disassembling the control side	6-6
6.1.6 Inspecting the orbit roll	6-9
6.1.7 Assembling the control side	6-9
6.1.8 Assembling the gerotor side	6-12
6.1.9 Orbit roll specifications	6-14
6.1.10 Troubleshooting	6-14
6.2 Fender	6-17

6.2.1	Removing the fender	6-17
6.2.2	Installing the fender	6-18
6.3	Engine cover	6-19
6.3.1	Removing the engine cover	6-19
6.3.2	Installing the engine cover	6-19
6.3.3	Head lamp and engine cover net	6-19
6.3.4	Side cover	6-20
6.4	Three-point linkage and drawbar	6-21
6.4.1	Three-point linkage	6-21
6.4.1.1	Draw bar	6-26
6.4.1.2	Maintaining drawbar components	6-26
6.4.2	Removing the lift cylinder case	6-27
6.5	Rear axle	6-29
6.5.1	General Information	6-29
6.5.2	Rear axle and brakes	6-29
6.5.3	Rear differential lock system and housing	6-31
6.6	Rear axle housing and differential gears	6-32
6.6.1	Disassembling the rear axle housing	6-32
6.6.2	Inspecting the rear axle and the brakes	6-34
6.6.3	Brake discs	6-34
6.6.4	Separator plates	6-35
6.7	Ring gear and pinion	6-36
6.7.1	Removing the ring gear and the pinion	6-36
6.7.2	Disassembling the ring gear and the pinion	6-37
6.7.3	Inspecting the ring gear and pinion assembly	6-38
6.7.4	Assembling the ring gear and the pinion	6-38
6.7.5	Installing the ring gear and the pinion	6-42
6.7.6	Backlash specification	6-42
6.7.7	Thrust collar specification	6-43
6.7.8	Tooth contact pattern	6-43
6.7.9	Assembling the pinion bevel	6-45
6.8	Brakes	6-46
6.8.1	Disassembling the brakes	6-47
6.8.2	Inspecting the brake discs and the separator plates	6-47
6.8.3	Checking the brake adjustment	6-47
6.8.4	Adjusting the brakes	6-48
6.9	Differential	6-49
6.9.1	Differential lock	6-49
6.10	Front axle	6-51
6.10.1	Removing the front axle	6-51
6.10.2	Front axle component inspection	6-52
6.10.3	Installing the front axle	6-54
6.10.4	Front axle components	6-55
6.10.5	Front axle specifications	6-57
6.10.6	Four-wheel drive shaft components	6-57
6.10.7	Hydraulic steering	6-58
6.10.8	Two-wheel drive front axle component	6-60
6.10.9	Two-wheel drive steering controller system	6-63
6.10.10	Two-wheel drive tie rod system	6-63
6.11	Front differential (four-wheel drive only)	6-64
6.11.1	Disassembling the pinion carrier	6-64
6.11.2	Overhauling the pinion carrier	6-65
6.11.3	Inspecting the pinion carrier	6-66
6.11.4	Assembling the pinion carrier	6-66
6.11.5	Disassembling the differential gears	6-67
6.11.6	Inspecting the differential gears	6-67

6.11.7	Assembling the differential gears	6-68
6.11.8	Final drive components	6-70
6.11.9	Removing the wheel shaft seal/cover	6-71
6.11.10	Installing the wheel shaft seal/cover	6-72
6.11.11	Removing the front axle center section	6-74
6.11.12	Installing the front axle center section	6-74
6.11.13	Removing the front axle bracket oil seal	6-74
6.11.14	Installing the front axle bracket oil seal	6-75
6.12	Final drive housing (four-wheel drive only)	6-76
6.12.1	Disassembling the final drive housing	6-76
6.12.2	Inspecting the final drive housing	6-77
6.12.3	Assembling the final drive housing	6-78
6.12.4	Tie rod assembly	6-80
6.13	Front wheel alignment	6-81
6.13.1	Adjusting the front wheel alignment	6-81
6.13.2	Steering free play	6-81
6.14	Front axle troubleshooting	6-82
7	Electrical	7-1
7.1	Wire color chart	7-3
7.2	Power shuttle general information	7-5
7.3	Wiring diagrams	7-6
7.3.1	Battery wiring diagram	7-7
7.3.2	Instrument panel wiring diagram	7-8
7.3.3	Head lamp wiring diagram	7-9
7.3.4	Controller wiring diagram	7-10
7.3.5	Cab wiring diagram	7-11
7.3.6	Main wiring diagram	7-12
7.3.6.1	7-13
7.3.6.2	7-13
7.3.7	Engine wiring diagram	7-14
7.3.7.1	7-15
7.3.8	Controller area wiring diagram	7-15
7.3.8.1	7-16
7.3.9	Cab1 wiring diagram	7-16
7.3.9.1	7-18
7.3.10	Cab2 wiring diagram	7-18
7.4	Instruments and controls	7-21
7.4.1	Removing the console	7-21
7.4.2	Mater panel switch	7-21
7.4.3	Removing the instrument panel	7-22
7.4.4	Installing the instrument panel	7-24
7.4.5	Instrument panel switch location diagram	7-27
7.4.6	Cab switch location diagram	7-28
7.4.6.1	7-28
7.4.7	Lever guide switch location diagram	7-29
7.4.8	Main fuse box - platform tractor	7-31
7.4.9	Main fuse box - cab tractor	7-33
7.5	Valves	7-35
7.5.1	Power shuttle valve	7-35
7.5.2	Power take-off valve	7-44
7.5.3	Solenoid valves	7-46
7.6	Position of the main electrical parts	7-50
7.6.1	Position of sub-change lever position sensor	7-50
7.6.2	Position of the air conditioner controller panel	7-50
7.6.3	Position of the air conditioner controller unit	7-51

7.6.4	Position of the cabin harness assembly	7-51
7.6.5	Position of the engine harness coupler	7-52
7.6.6	Position of the head lamp	7-52
7.6.7	Position of the horn	7-52
7.6.8	Position of the starter	7-53
7.7	Sensor initial adjustment	7-54
7.7.1	Calibrating the three-point hitch	7-54
7.7.2	Lift arm and draft sensor	7-57
7.7.3	Control lever	7-58
7.7.4	Fuse box	7-58
7.7.5	Depth dial	7-59
7.7.6	Lift lamp	7-59
7.7.7	Main switch	7-60
7.7.8	Calibrating the clutch pedal switch and sensor	7-60
7.7.9	Clutch pedal	7-62
7.7.10	Clutch pedal sensor	7-63
7.7.11	Clutch pedal switch	7-63
7.7.12	Forward/reverse lever	7-64
7.7.13	Calibrating the clutch initial time	7-64
7.7.14	Range shift lever	7-65
7.7.15	Gear shift lever	7-65
7.7.16	Parking lever switch	7-66
7.7.17	Brake pedal switch	7-66
7.7.18	Throttle lever	7-67
7.7.19	Instrument panel	7-67
7.8	Electrical and hydraulic control system	7-68
7.9	Main clutch system	7-70
7.10	Electronic diagnostic tool	7-72
7.10.1	Engine service tool software license	7-72
7.10.2	Connecting the electronic diagnostic tool	7-72
7.11	Fault code tree	7-73
7.12	Diagnostic codes	7-75
7.12.1	SPN 1001 FMI 1	7-75
7.12.2	SPN 1001 FMI 2	7-78
7.12.3	SPN 1001 FMI 3	7-81
7.12.4	SPN 1002 FMI 1	7-84
7.12.5	SPN 1002 FMI 2	7-87
7.12.6	SPN 1002 FMI 3	7-90
7.12.7	SPN 1004 FMI 1	7-93
7.12.8	SPN 1004 FMI 2	7-96
7.12.9	SPN 1004 FMI 3	7-99
7.12.10	SPN 3055 FMI 1	7-102
7.12.11	SPN 3055 FMI 2	7-104
7.12.12	SPN 3057 FMI 1	7-106
7.12.13	SPN 3057 FMI 2	7-108
7.12.14	SPN 3151 FMI 06	7-110
7.12.15	SPN 3151 FMI 07	7-113
7.12.16	SPN 3151 FMI 08	7-115
7.12.17	SPN 3151 FMI 09	7-118
7.12.18	SPN 3152 FMI 04	7-121
7.12.19	SPN 3156 FMI 08	7-124
7.12.20	SPN 3156 FMI 09	7-127
7.12.21	SPN 3351 FMI 21	7-130
7.12.22	SPN 3351 FMI 22	7-133
7.12.23	SPN 3352 FMI 21	7-136
7.12.24	SPN 3352 FMI 22	7-139

8 Hydraulics	8-1
8.1 Hydraulic schematic	8-3
8.1.1 Hydraulic schematic	8-5
8.2 Specifications	8-7
8.2.1 Power shuttle transmission specifications	8-10
8.3 Transmission oil cooler and lubrication	8-11
8.4 General service procedures	8-13
8.4.1 Transmission oil	8-13
8.4.2 Checking the transmission oil level	8-13
8.4.3 Changing the transmission oil and filter	8-13
8.5 Suction filter	8-15
8.5.1 Suction filter specifications	8-15
8.5.2 Suction filter operation	8-16
8.5.3 Suction filter maintenance	8-16
8.6 Gear pump	8-17
8.6.1 Main pump	8-17
8.6.2 Sub pump	8-18
8.7 Cylinders	8-19
8.7.1 Power steering cylinder	8-19
8.7.2 Main cylinder	8-21
8.7.3 Main cylinder specifications	8-23
8.7.4 Assist cylinder, if equipped	8-23
8.8 Valves	8-25
8.8.1 Main relief valve	8-25
8.8.2 Installing the main relief valve	8-26
8.8.3 Main relief valve specifications	8-26
8.8.4 Main control valve	8-27
8.8.5 Steering orbit roll	8-28
8.8.6 Slow return valve	8-29
8.8.7 Assembling precautions for the slow return valve	8-30
8.8.8 Slow return valve specifications	8-30
8.8.9 Safety valve	8-31
8.8.10 Assembling precautions for the safety valve	8-31
8.8.11 Safety valve specifications	8-31
8.8.12 Power takeoff control valve	8-32
8.8.13 Assembling precautions for the power takeoff control valve	8-33
8.8.14 Power takeoff control valve specifications	8-33
8.8.15 Reduce valve	8-34
8.8.16 Assembling precautions for the reduce valve	8-36
8.8.17 Reduce valve specifications	8-37
8.8.18 Control valve	8-37
8.8.19 Assembling precautions for the control valve	8-41
8.8.20 Control valve specifications	8-41
8.8.21 High-low valve (P1 type only)	8-42
8.8.22 Joystick valve (J type only)	8-44
8.8.23 Joystick valve specifications	8-48
8.8.24 Boom valve operation	8-49
8.8.25 Bucket valve operation	8-54
8.8.26 Remote control valve	8-57
8.8.27 Remote control valve specifications	8-57
8.8.28 Removing the remote control valve	8-58
8.8.29 Remote control valve assembly	8-58
8.8.30 Installing the remote control valve	8-59
8.9 Parts and hydraulic diagrams	8-60
8.9.1 Front loader adapter	8-60

8.9.2 External auxiliary hydraulics	8-61
8.9.3 Hydraulic control linkage	8-62
8.9.4 Auxiliary hydraulic valves	8-65
8.9.5 Joystick link and lever	8-67
8.9.6 Position control sensor and lever	8-77
8.9.7 Adjusting the position control lever	8-78
8.9.8 Three-point linkage	8-79
8.9.9 Three-point linkage specifications	8-80
8.9.10 Drawbar	8-81
8.10 Hydraulic system troubleshooting	8-82
9 Index	Index-1

Appendix “A”

AGCO Power Engine Diagnostic fault codes and trees	Appendix
--	----------

1. Introduction

1.1 Introduction	1-3
1.1.1 The service manual	1-3
1.1.2 Replacement parts	1-3
1.1.3 Units of measurement	1-3
1.1.4 Machine identification	1-3
1.1.5 Serial number plate	1-4
1.1.6 Engine identification	1-4
1.1.7 Chassis number	1-5
1.2 Specifications	1-6
1.2.1 Engine specifications	1-6
1.2.2 Electrical specifications	1-6
1.2.3 Transmission specifications	1-7
1.2.4 Power takeoff specifications	1-7
1.2.5 Front axle specifications	1-7
1.2.6 Rear axle specifications	1-8
1.2.7 Brake specifications	1-8
1.2.8 Hydraulic specifications	1-8
1.2.9 Fuel specifications	1-8
1.2.10 Operating slope angle	1-9
1.2.11 Lubrication specifications	1-9
1.2.12 Capacities	1-10
1.2.13 Maximum load capacity	1-10
1.2.14 Wheel bolt torque chart	1-11
1.2.15 Tire inflation pressures	1-12
1.3 General dimensions	1-14
1.3.1 Platform tractor dimensions	1-14
1.3.2 Cab tractor dimensions	1-15
1.4 Lubrication / fill points	1-17
1.4.1 Lubrication and maintenance chart	1-17
1.4.2 Initial lubrication and maintenance chart	1-18
1.4.3 Lubrication fill and drain locations	1-19
1.5 General precautions for disassembly and installation	1-20
1.5.1 Precautions for disassembling and installing	1-20
1.5.2 Precautions when installing according to standards parts	1-20
1.6 Tightening torque chart	1-23
1.7 Conversion table	1-25

1.1 Introduction

1.1.1 The service manual

Read the table of contents and basic layout. Become familiar with all parts of this service manual. This service manual gives the technician very important information.

Machine movement when in normal use determines right-hand and left-hand.

This manual covers general safety practices for this machine.

The photos, illustrations, and data used in this manual were current at the time of printing. Inline production changes can make machines vary from the information in the service manual. The manufacturer reserves the right to redesign and change the machine as necessary without notification.



WARNING:

In some of the illustrations and photos used in this manual, shields or guards may have been removed for clarity. Never operate the machine with any shields or guards removed. If the removal of shields or guards is necessary to make a repair, they must be replaced before operation.

1.1.2 Replacement parts

To receive prompt efficient service, remember to have the following information:

- Correct part description and part number
- Model number of the machine
- Serial number of the machine

1.1.3 Units of measurement

Measurements are given in metric units followed by the equivalent in US units. Hardware sizes are given in millimeters for metric hardware and inches for US hardware.

1.1.4 Machine identification

Each machine is identified by a model and a serial number.

Record these numbers in the spaces given.

Give the model number and serial number to your dealer when parts or service are required.

Machine model number:	
Machine serial number:	

Date of delivery:	
-------------------	--

Dealer name:	
Dealer address:	
Dealer telephone number:	
Dealer e-mail address:	
Dealer fax number	

1.1.5 Serial number plate

The serial number plate (1) is located below the operator seat.

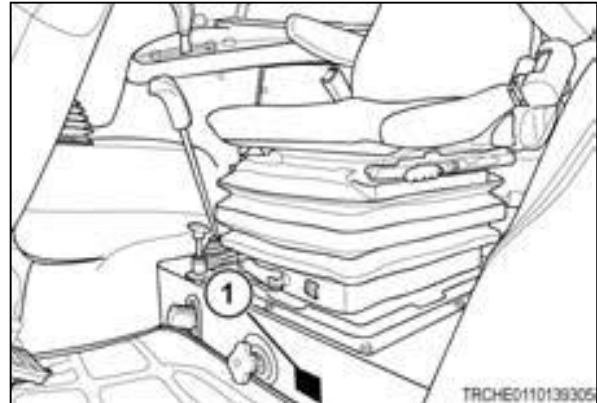

Fig. 1

The serial number plate contains the model number and serial number.

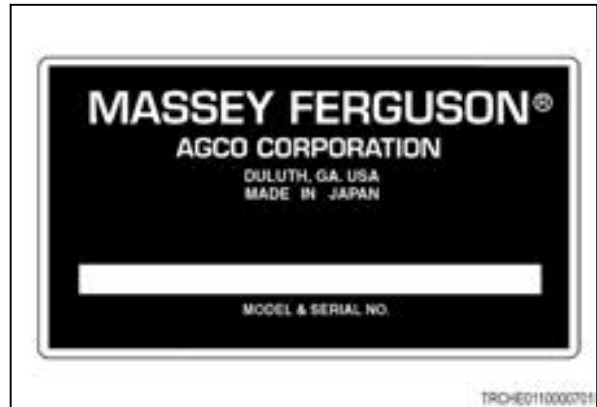

Fig. 2

1.1.6 Engine identification

The engine model number (1) is cast on the right-hand side of the engine block, below the injection pump.

The engine serial number (2) is stamped into the cylinder block, below the engine model number.

Engine model number:	
Engine serial number:	

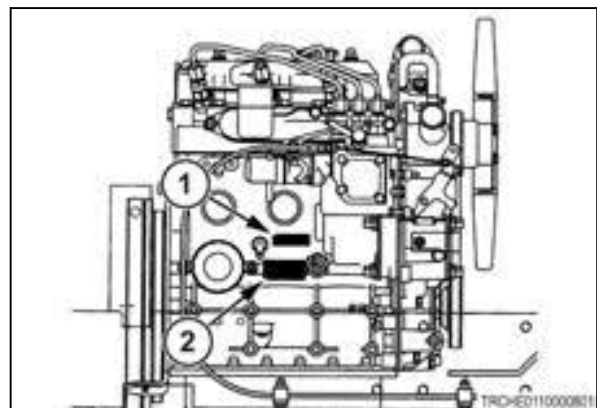

Fig. 3

1.1.7 Chassis number

The chassis number (1) is stamped in right-hand side of front frame.

Chassis number:	
-----------------	--

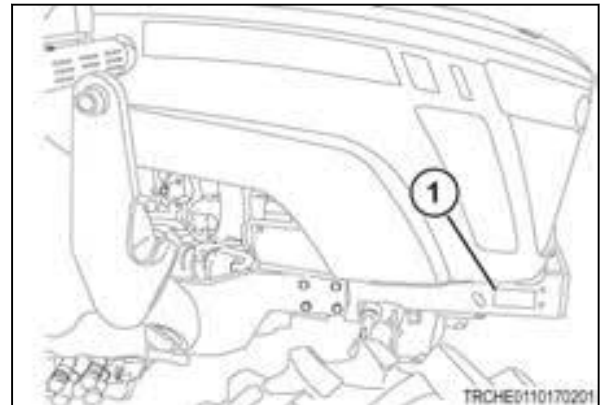

Fig. 4

1.2 Specifications

1.2.1 Engine specifications

	4608	4609	4610
Type	Four stroke diesel engine		
Model	33 AWIC		
Make	AGCO power		
Number of cylinders	3		
Aspiration	Turbocharged and air to air intercooled		
Injection	Direct		
Bore	108 mm		
Stroke	120 mm		
Displacement	3.3 L		
Rated speed	2200 rpm		
Low idle speed	912 to 988 rpm		
High idle speed	2218 to 2402 rpm		
Maximum torque at rpm	346 Nm at 1500 rpm	387 Nm at 1500 rpm	410 Nm at 1500 rpm
Engine horse power (Maximum output)	63 kW at 2000 rpm	71 kW at 2000 rpm	75 kW at 2000 rpm
Engine cooling	Liquid, forced circulation		
Air cleaner	Dual stage, dry element		
Air intake	Engine cover grille		
Cold starting aid	Intake heater		
Firing order	1-2-3		
Valve clearance (cold)	0.35 mm		

1.2.2 Electrical specifications

	4608	4609	4610
System voltage	12 volt		
Grounding	Negative		
Battery cold cranking amperes (cca) @ - 18 °C	799 cca		
Battery JIS type	130E41R		
Battery case dimensions			
Length	410 mm		
Width	175 mm		
Height	234 mm		
Alternator	12 volt, 95 ampere		
Starter	12 volt, 3.0 kW		

1.2.3 Transmission specifications

	4608	4609	4610
Primary transmission	Six speed synchronized		
Range transmission	Without creep gear, two speed sliding mesh		
	With creep gear, three speed sliding mesh		
Mechanical shuttle	Electro-hydraulic control with multi plate wet disc, 95% reverse reduction		
Gear speeds			
Power shuttle	Without creep gear, 12 forward, 12 reverse		
	With creep gear, 18 forward, 18 reverse		
Clutch	Multiple stage wet with 128 mm disc		

1.2.4 Power takeoff specifications

	4608	4609	4610
Type	Independent, engine driven		
Control	Electro-hydraulic control		
Clutch	Hydraulically engaged, multi-plate wet disk		
Output	Clockwise rotation from the rear of the tractor		
Shaft			
540 rpm (North America only)	35 mm diameter, 6 spline, ISO type 1		
1000 rpm (North America only)	35 mm diameter, 21 spline, ISO type 2		
540/750 rpm (Australia)	35 mm diameter, 6 spline, ISO type 1		
Engine speed			
540 rpm	1993 rpm		
1000 rpm (North America only)	2178 rpm		
750 rpm (Australia only)	2129 rpm		

1.2.5 Front axle specifications

	4608	4609	4610
Engagement	Mechanical		
Joint on axle	Bevel gear		
Oscillation angle	6 to 8 degrees		
Steering	Hydrostatic		
Rear wheel to front wheel drive ratio	1:1 .45	1:1 .4	

1.2.6 Rear axle specifications

	4608	4609	4610
Final reduction	Planetary		

1.2.7 Brake specifications

	4608	4609	4610
Type	Wet multi disc		
Actuation	Mechanical		
Braking area	467.36 sq cm (72.68 sq in) x 8 pieces		
Parking brake	Hook type		

1.2.8 Hydraulic specifications

	4608	4609	4610
Main hydraulic system			
Pump	Transmission mounted		
Maximum output	66.5 l/min		
Pressure	19.6 mPa		
Steering system			
Type	Hydrostatic		
Pump	Transmission mounted		
Maximum output	25.7 l/min		
Pressure	15.8 mPa		
Rear linkage			
Type	Three-point hitch		
Size	Category II		
Control	Single control lever		
Lift capacity - measured at ball ends			
Standard:	2500 kg		
Optional:	3300 kg		
Lift capacity - measured at 610 mm			
Standard:	1500 kg		
Optional:	2000 kg		

1.2.9 Fuel specifications

	4608	4609	4610
Type	Ultra low sulfur fuel only		
Above 4 °C	No. 2-D		
Below 4 °C	No. 1-D		

Thank you so much for reading.
Please click the “Buy Now!”
button below to download the
complete manual.



After you pay.

You can download the most
perfect and complete manual in
the world immediately.

Our support email:

ebooklibonline@outlook.com