

MASSEY FERGUSON

MF 9000

Series Planter Row Unit



SERVICE MANUAL

FROM MASSEY FERGUSON

Massey Ferguson®

9000 Series Planter Row Unit

SERVICE MANUAL 4283527M1

CONTENTS

GAUGE WHEELS	01
CLOSING WHEELS	02
ROW UNIT LINKAGE	03
PNEUMATIC DOWN PRESSURE	04
ROW UNIT DRIVES	05
SEED METERS	06
INDEX	07

NOTES

Massey Ferguson®

**9000 Series
Planter Row Unit**

**WORKSHOP SERVICE MANUAL
4283527M1**

01 - Gauge Wheels

Contents

GAUGE WHEELS

General Information	01-3
Gauge Wheels	01-3
Tire to Opener Disc Clearance Adjustment	01-3
Gauge Wheel Arm Components	01-4
Seals Replacement	01-6
Bearing Replacement	01-9
Bushing, Bearing Rod and Seal Replacement	01-13
Gauge Wheel Mounting	01-21
Gauge Wheel Repair	01-22
Openers	01-23
Disc Blade Replacement and Adjustment	01-23
Scraper	01-24
Seed Tubes	01-25
Sensor Cleaning	01-25
Tube Guard	01-25
Row Unit Lower Assembly	01-26
Depth Gauge	01-27
Removal	01-27
Disassembly	01-29
Assembly	01-31
Installation	01-33

Contents

GAUGE WHEELS

GENERAL INFORMATION

The row unit has two depth gauge wheels, one on each side of the lower frame. Each wheel raises and lowers independently, so when one wheel rides over an obstacle the other remains at ground level. As a result, the row unit raises only half the distance of the highest wheel to help maintain correct planting depth.

GAUGE WHEELS

Before working on row units:

- Park the planter on a solid, level surface.
- Install the transport lockup channels on the planter before working.
- Turn tractor off and take key with you.

Tire to Opener Disc Clearance Adjustment

FIG. 1: General Information

Gauge wheel tire (1) to opener disc (2) clearance must be between 0 to 1.6 mm (0.0625 in) (A).

The tires can lightly rub opener discs and the discs must rotate freely.

Adjustment Procedure

Loosen the lock bolt (3).

NOTE: Loctite is applied to the lock bolt at the factory.

Rotate the bushing (4) until the correct clearance is reached.

Tighten the locking bolt.

Repeat procedures on both sides as needed.

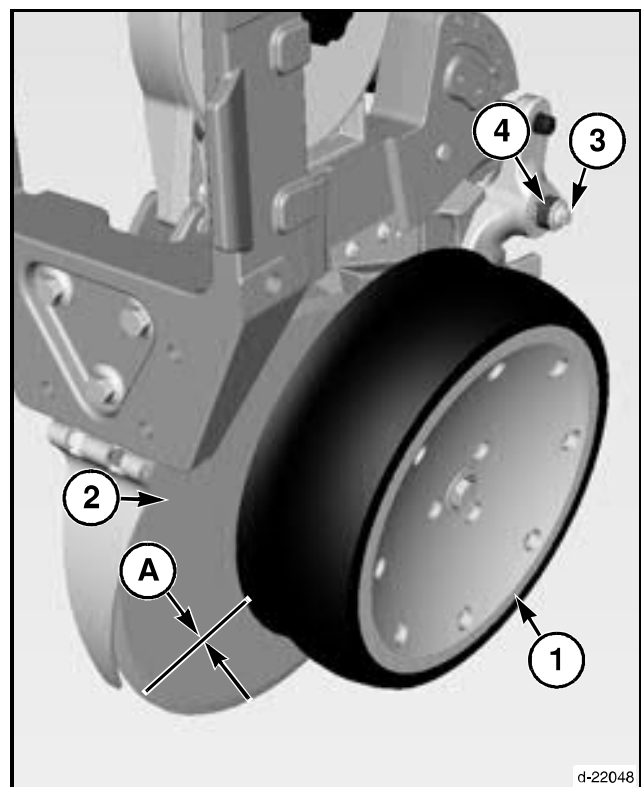

FIG. 1

Gauge Wheels

Gauge Wheel Arm Components

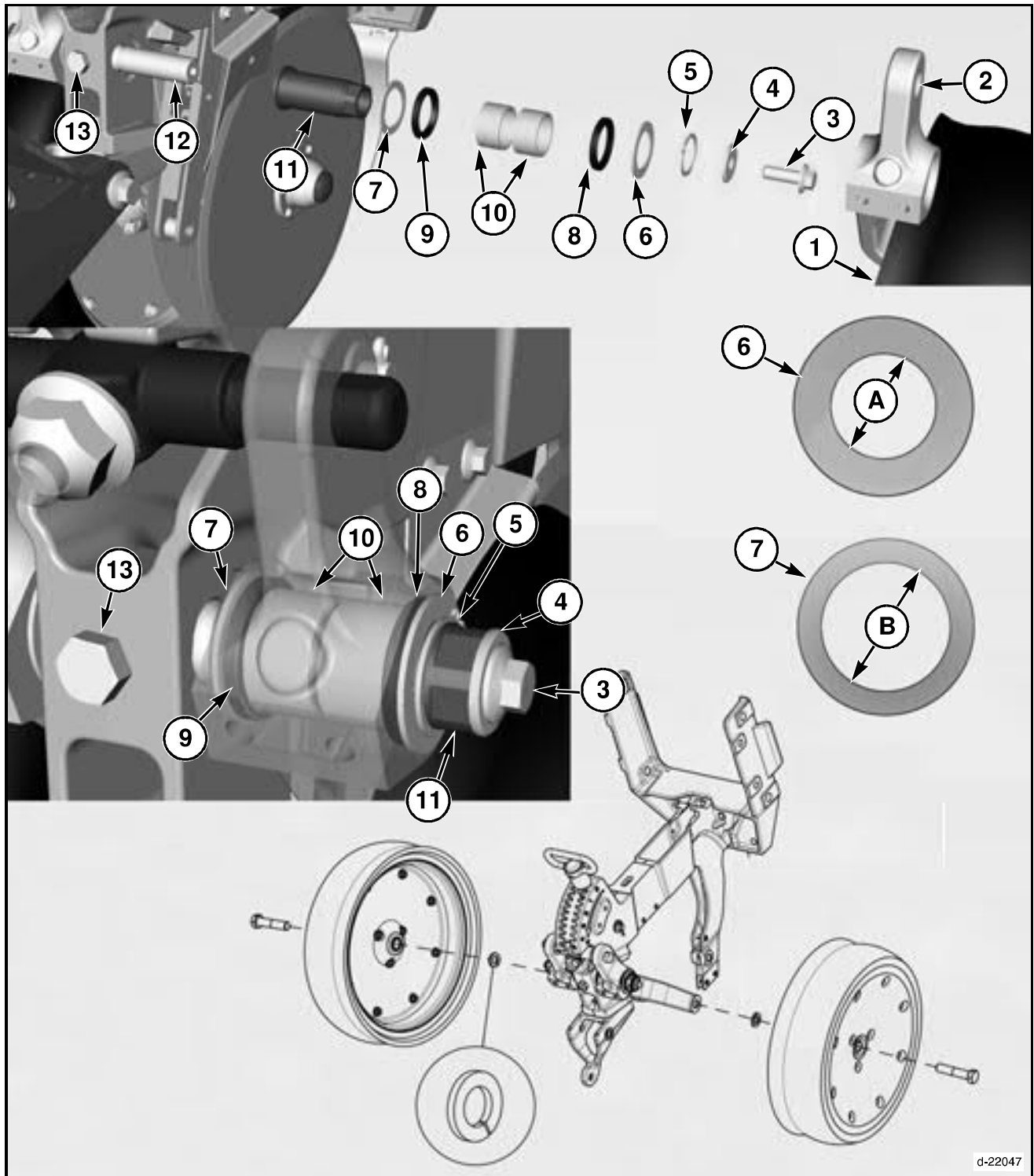

FIG. 2

FIG. 2: Components List

NOTE: All components are identical on the left-hand and right-hand gauge wheel arm assembly.

- | | |
|-------------------------------|--|
| (1) Gauge Tire | (3) Locking bolt |
| (2) Gauge wheel arm assembly. | (4) Washer |
| | (5) Retaining Ring |
| | (6) 31 mm (1.25 in) (A) ID: Outside Spacer |

- (7) 33 mm (1.3 in) (B) ID: Inside Spacer
- (8) Outer Seal
- (9) Inner Seal
- (10) Bearings
- (11) Hex Head Bushing
- (12) Threaded Rod
- (13) Set Screw

Gauge Wheels

Seals Replacement

Following procedure will replace the seals in the gauge wheel arm .

NOTE: The component replacement procedures are the same for the left-hand and right-hand side of the row unit.

Disassembly

FIG. 3: Lower the depth adjustment handle (1) or raise the row unit off of the ground.

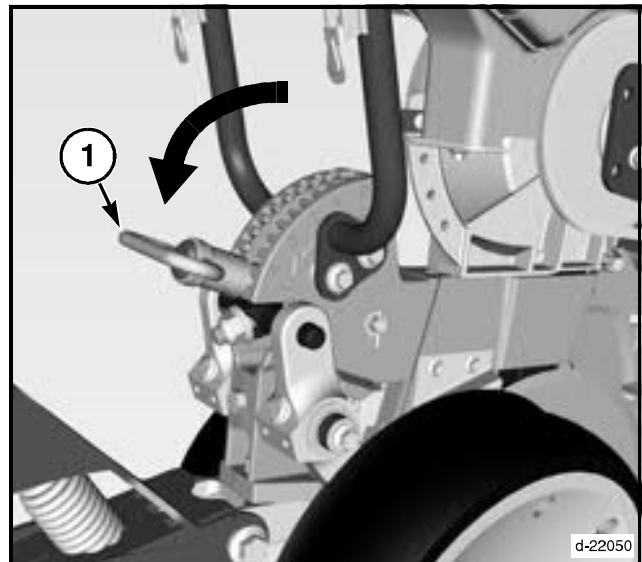

FIG. 3

FIG. 4: Remove the retaining ring (1).
Remove the outside spacer (2).

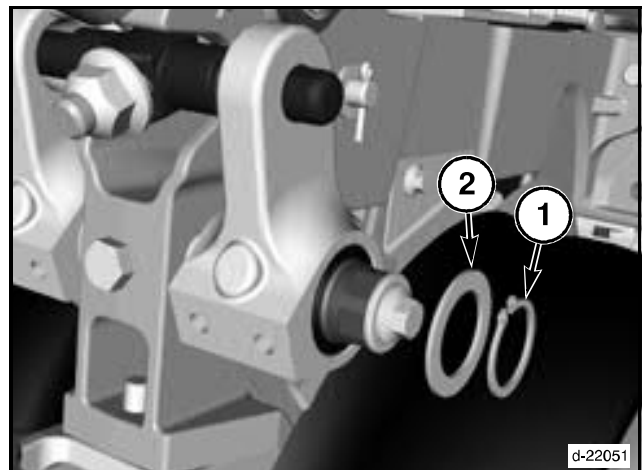

FIG. 4

FIG. 5: Remove the gauge wheel arm assembly (1).
Remove the spacer (2).

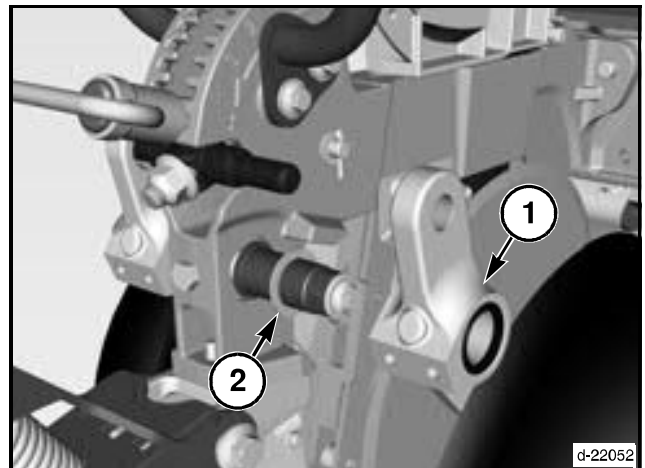

FIG. 5

FIG. 6: Remove the outer seal (1) and inner seal (2).

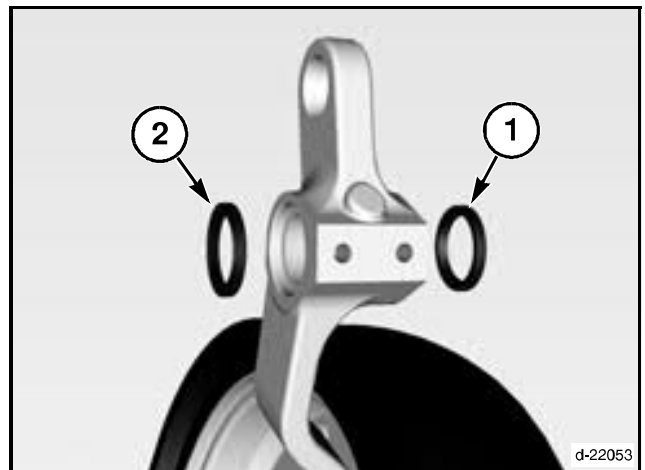

FIG. 6

Assembly

FIG. 7: Install the outer seal (1) and inner seal (2).

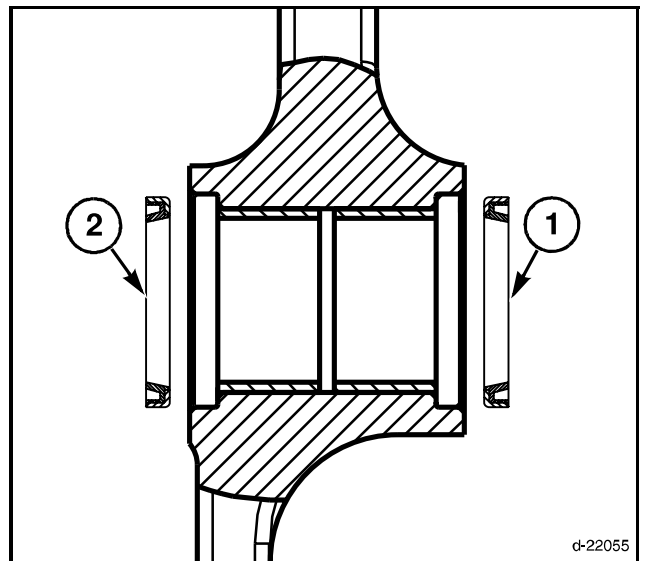

FIG. 7

Gauge Wheels

FIG. 8: Install the 33 mm (1.3 in) ID inside spacer (1).

NOTE: The inside spacer ID is bigger than the outside spacers ID.

Install the gauge wheel arm assembly (2).

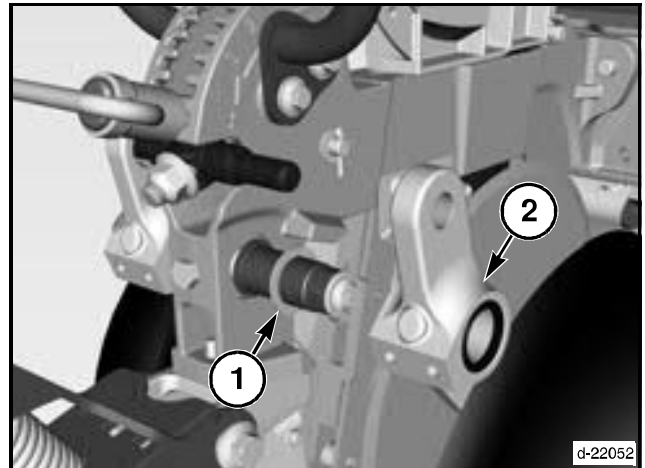

FIG. 8

FIG. 9: Install the 31 mm (1.25 in) ID outside spacer (1).

NOTE: The outside spacer ID is smaller than the inside spacers ID.

Install the retaining ring (2).

IMPORTANT: Make sure the retaining ring is fully seated. Damage will occur.

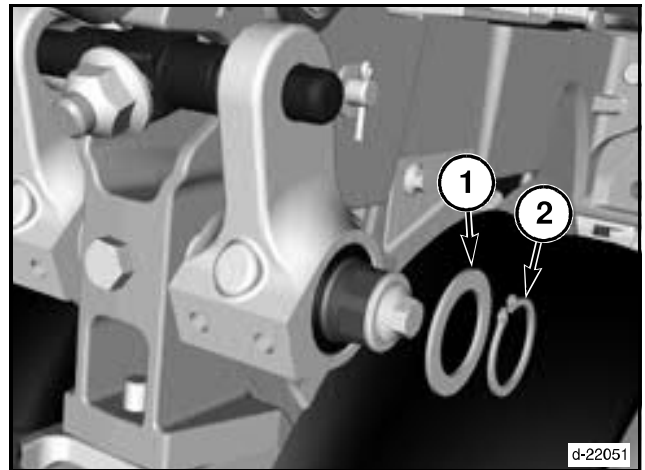

FIG. 9

Thank you so much for reading.
Please click the “Buy Now!”
button below to download the
complete manual.



After you pay.

You can download the most
perfect and complete manual in
the world immediately.

Our support email:

ebooklibonline@outlook.com