

**Workshop Service Manual**

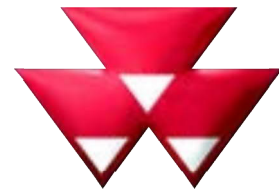

**MASSEY FERGUSON**

# **1383 / 1386 Rotary Disc Mower**

**1383**

**1386**

**North America**  
**4205 River Green Parkway, Duluth GA 30096 USA**  
**© AGCO 2015**

**January 2015**  
**4283556M2**  
**NA**  
**English**

# 1383 / 1386 Rotary Disc Mower

<b>1 General</b>	1-1
<b>1.1 General information</b>	1-3
1.1.1 Introduction to this service manual	1-3
1.1.2 Units of measurement	1-3
1.1.3 Table of contents	1-3
1.1.4 Page numbers	1-3
1.1.5 Intended use	1-3
1.1.6 Proper disposal of waste	1-3
<b>1.2 Safety</b>	1-5
1.2.1 Introduction	1-5
1.2.1.1 Safety alert symbol	1-5
1.2.1.2 Safety messages	1-5
1.2.1.3 Informational messages	1-5
1.2.1.4 Safety signs	1-5
1.2.1.5 A word to the operator	1-6
1.2.1.6 This manual	1-7
1.2.1.7 Operator manual holder	1-7
1.2.2 Operation	1-7
1.2.2.1 Prepare for operation	1-7
1.2.2.2 General information	1-8
1.2.2.3 Personal protective equipment	1-9
1.2.2.4 Seat instructions	1-9
1.2.2.5 Shield and guards	1-10
1.2.2.6 Exhaust warning	1-10
1.2.2.7 Flying debris	1-11
1.2.2.8 Agricultural chemicals	1-11
1.2.3 Travel on public roads	1-11
1.2.4 Maintenance	1-12
1.2.4.1 General maintenance information	1-12
1.2.4.2 Fire prevention and first aid	1-14
1.2.4.3 High pressure leaks	1-15
1.2.4.4 Accumulator safety	1-16
1.2.4.5 Replacement parts	1-16
<b>1.3 Cylinder stops</b>	1-17
1.3.1 Lift cylinder lockout valves	1-17
1.3.1.1 Engaging the lift cylinder lockout valves	1-17
1.3.1.2 Disengaging the lift cylinder lockout valves	1-18
1.3.2 Steering cylinder lockout valves	1-19
1.3.2.1 Engaging the steering cylinder lockout valves	1-20
1.3.2.2 Disengaging the steering cylinder lockout valves	1-20
<b>1.4 Machine identification</b>	1-21
1.4.1 Serial number plate	1-21
1.4.2 Tongue serial number	1-21
1.4.3 Serial number description	1-22
<b>1.5 Specifications</b>	1-23
1.5.1 Dimensions and weights	1-23
1.5.2 Header specifications	1-23
1.5.3 Cutterbed specifications	1-23
1.5.3.1 Cutterbed bolt torque	1-23
1.5.4 Drive system specifications	1-24
1.5.5 Tire specification	1-24

1.5.6	Tractor specifications . . . . .	1-24
1.5.7	Maximum roading speed . . . . .	1-24
1.5.8	Hay conditioner specifications . . . . .	1-24
1.5.9	Lubrication specifications . . . . .	1-25
<b>1.6</b>	<b>Description of a pull type rotary mower conditioner . . . . .</b>	<b>1-27</b>
1.6.1	Cutterbed . . . . .	1-27
1.6.2	Hay conditioner . . . . .	1-27
1.6.3	Swathboard . . . . .	1-27
1.6.4	Forming shields . . . . .	1-27
1.6.5	Component access . . . . .	1-28
1.6.6	Component location . . . . .	1-29
<b>1.7</b>	<b>Bearing replacement . . . . .</b>	<b>1-31</b>
1.7.1	Removing an eccentric locking collar . . . . .	1-31
1.7.2	Installing an eccentric locking collar . . . . .	1-31
<b>2</b>	<b>Drive system . . . . .</b>	<b>2-1</b>
<b>2.1</b>	<b>Implement driveline . . . . .</b>	<b>2-5</b>
2.1.1	Removing the implement driveline . . . . .	2-5
2.1.2	Installing the implement driveline . . . . .	2-6
<b>2.2</b>	<b>Tongue driveline . . . . .</b>	<b>2-7</b>
2.2.1	Tongue driveline components . . . . .	2-7
2.2.2	Removing the tongue driveline . . . . .	2-7
2.2.3	Inspecting the tongue driveline . . . . .	2-9
2.2.4	Installing the tongue driveline . . . . .	2-9
<b>2.3</b>	<b>Intermediate driveline - 5 m (16 ft) header . . . . .</b>	<b>2-11</b>
2.3.1	Removing the intermediate driveline . . . . .	2-11
2.3.2	Installing the intermediate driveline . . . . .	2-12
<b>2.4</b>	<b>Clutch driveline . . . . .</b>	<b>2-14</b>
2.4.1	Removing the clutch driveline . . . . .	2-14
2.4.2	Installing the clutch driveline . . . . .	2-15
<b>2.5</b>	<b>Slip clutch . . . . .</b>	<b>2-17</b>
2.5.1	Slip clutch components . . . . .	2-17
2.5.2	Running in the slip clutch . . . . .	2-17
2.5.3	Removing the slip clutch . . . . .	2-17
2.5.4	Disassembling the slip clutch . . . . .	2-19
2.5.5	Inspecting the slip clutch . . . . .	2-21
2.5.6	Assembling the slip clutch . . . . .	2-22
2.5.7	Installing the slip clutch . . . . .	2-24
<b>2.6</b>	<b>Overrunning clutch . . . . .</b>	<b>2-26</b>
2.6.1	Removing the overrunning clutch . . . . .	2-26
2.6.2	Disassembling the overrunning clutch . . . . .	2-27
2.6.3	Inspecting the overrunning clutch . . . . .	2-29
2.6.4	Assembling the overrunning clutch . . . . .	2-29
2.6.5	Installing the overrunning clutch . . . . .	2-30
<b>2.7</b>	<b>Cutterbed driveline . . . . .</b>	<b>2-33</b>
2.7.1	Removing the cutterbed driveline . . . . .	2-33
2.7.2	Installing the cutterbed driveline . . . . .	2-34
<b>2.8</b>	<b>Hay conditioner drivelines . . . . .</b>	<b>2-36</b>
2.8.1	Removing the hay conditioner drivelines . . . . .	2-36
2.8.2	Inspecting the hay conditioner drivelines . . . . .	2-38
2.8.3	Installing the hay conditioner drivelines . . . . .	2-38
<b>2.9</b>	<b>Universal joint bearing replacement . . . . .</b>	<b>2-41</b>
2.9.1	Disassembling a universal joint . . . . .	2-41
2.9.2	Inspecting a universal joint . . . . .	2-43
2.9.3	Assembling a universal joint . . . . .	2-43
<b>2.10</b>	<b>Quick disconnect . . . . .</b>	<b>2-46</b>

2.10.1	Disassembling the quick disconnect	2-46
2.10.2	Inspecting the quick disconnect	2-47
2.10.3	Assembling the quick disconnect	2-47
<b>2.11</b>	<b>Belts - 4 m (13 ft) header</b>	<b>2-49</b>
2.11.1	Belt maintenance	2-49
2.11.2	Belt inspection	2-49
2.11.3	Adjusting the hay conditioner belt	2-49
2.11.4	Replacing the hay conditioner belt	2-49
2.11.5	Adjusting the helper roll belt	2-51
2.11.6	Replacing the helper roll belt	2-51
2.11.7	Adjusting the header drive belt	2-52
2.11.8	Replacing the header drive belt	2-52
<b>2.12</b>	<b>Belts - 5 m (16 ft) header</b>	<b>2-54</b>
2.12.1	Belt maintenance	2-54
2.12.2	Belt inspection	2-54
2.12.3	Adjusting the hay conditioner belt	2-54
2.12.4	Replacing the hay conditioner belt	2-54
2.12.5	Adjusting the center cage belt	2-56
2.12.6	Replacing the center cage belt	2-56
2.12.7	Adjusting the header drive belt	2-57
2.12.8	Replacing the header drive belt	2-57
<b>2.13</b>	<b>Hay conditioner gearcase lubrication</b>	<b>2-59</b>
2.13.1	Hay conditioner gearcase plug location - 4 m (13 ft) header	2-59
2.13.2	Hay conditioner gearcase plug location - 5 m (16 ft) header	2-59
2.13.3	Checking the gearcase oil level	2-59
2.13.4	Changing the gearcase oil	2-59
<b>2.14</b>	<b>Hay conditioner gearcase - 4 m (13 ft) header</b>	<b>2-61</b>
2.14.1	Hay conditioner gearcase components - 4 m (13 ft)	2-61
2.14.2	Removing the hay conditioner gearcase - 4 m (13 ft)	2-62
2.14.3	Disassembling the hay conditioner gearcase - 4 m (13 ft)	2-63
2.14.4	Inspecting the hay conditioner gearcase - 4 m (16 ft)	2-64
2.14.5	Assembling the hay conditioner gearcase - 4 m (13 ft)	2-65
2.14.6	Installing the hay conditioner gearcase - 4 m (13 ft)	2-69
<b>2.15</b>	<b>Hay conditioner gearcase - 5 m (16 ft) header</b>	<b>2-71</b>
2.15.1	Hay conditioner gearcase components - 5 m (16 ft)	2-71
2.15.2	Removing the hay conditioner gearcase - 5 m (16 ft)	2-71
2.15.3	Disassembling the hay conditioner gearcase - 5 m (16 ft)	2-73
2.15.4	Inspecting the hay conditioner gearcase - 5 m (16 ft)	2-75
2.15.5	Assembling the hay conditioner gearcase - 5 m (16 ft)	2-76
2.15.6	Installing the hay conditioner gearcase - 5 m (16 ft)	2-81
<b>2.16</b>	<b>Header drive gearbox</b>	<b>2-84</b>
2.16.1	Plug location - header drive gearbox	2-84
2.16.2	Checking the gearbox oil level	2-84
2.16.3	Changing the gearbox oil	2-84
2.16.4	Header drive gearbox components	2-85
2.16.5	Removing the header drive gearbox	2-86
2.16.6	Disassembling the header drive gearbox	2-89
2.16.7	Assembling the header drive gearbox	2-91
2.16.8	Installing the header drive gearbox	2-94
<b>2.17</b>	<b>Cutterbed drive gearbox</b>	<b>2-98</b>
2.17.1	Plug location - cutterbed drive gearbox	2-98
2.17.2	Checking the gearbox oil level	2-98
2.17.3	Changing the gearbox oil	2-98
2.17.4	Removing the cutterbed drive gearbox	2-99
2.17.5	4 m (13 ft) header	2-104
2.17.5.1	Cutterbed drive gearbox components	2-104
2.17.5.2	Disassembling the cutterbed drive gearbox	2-105

2.17.5.3 Assembling the cutterbed drive gearbox . . . . .	2-107
2.17.6 5 m (16 ft) header . . . . .	2-110
2.17.6.1 Cutterbed drive gearbox components . . . . .	2-110
2.17.6.2 Disassembling the cutterbed drive gearbox . . . . .	2-111
2.17.6.3 Assembling the cutterbed drive gearbox . . . . .	2-112
2.17.7 Installing the cutterbed drive gearbox . . . . .	2-115
<b>2.18 Swivel gearbox . . . . .</b>	<b>2-120</b>
2.18.1 Plug location - swivel gearboxes . . . . .	2-120
2.18.2 Checking the gearbox oil level . . . . .	2-120
2.18.3 Changing the gearbox oil . . . . .	2-120
2.18.4 Removing the swivel gearbox . . . . .	2-121
2.18.5 Installing the swivel gearbox . . . . .	2-121
2.18.6 Swivel gearbox - 4 m (13 ft) header . . . . .	2-123
2.18.6.1 Swivel gearbox components . . . . .	2-123
2.18.6.2 Disassembling the swivel gearbox . . . . .	2-124
2.18.6.3 Assembling the swivel gearbox . . . . .	2-128
2.18.7 Swivel gearbox - 5 m (16 ft) header . . . . .	2-135
2.18.7.1 Swivel gearbox components . . . . .	2-135
2.18.7.2 Disassembling the swivel gearbox . . . . .	2-136
2.18.7.3 Assembling the swivel gearbox . . . . .	2-140
<b>3 Hydraulic system . . . . .</b>	<b>3-1</b>
<b>3.1 General hydraulic information . . . . .</b>	<b>3-3</b>
<b>3.2 Steering cylinder . . . . .</b>	<b>3-4</b>
3.2.1 Removing the steering cylinder . . . . .	3-4
3.2.2 Steering cylinder components . . . . .	3-5
3.2.3 Disassembling the steering cylinder . . . . .	3-5
3.2.4 Inspecting the cylinder assembly . . . . .	3-6
3.2.5 Assembling the steering cylinder . . . . .	3-7
3.2.6 Installing the steering cylinder . . . . .	3-8
<b>3.3 Lift cylinders . . . . .</b>	<b>3-9</b>
3.3.1 General lift cylinder information . . . . .	3-9
3.3.2 Removing a lift cylinder . . . . .	3-9
3.3.3 Master cylinder components . . . . .	3-11
3.3.4 Slave cylinder components . . . . .	3-12
3.3.5 Disassembling a lift cylinder . . . . .	3-12
3.3.6 Inspecting the cylinder assembly . . . . .	3-13
3.3.7 Assembling a lift cylinder . . . . .	3-14
3.3.8 Installing a lift cylinder . . . . .	3-15
<b>3.4 Tilt cylinder . . . . .</b>	<b>3-17</b>
3.4.1 Removing the tilt cylinder . . . . .	3-17
3.4.2 Tilt cylinder components . . . . .	3-18
3.4.3 Disassembling the tilt cylinder . . . . .	3-18
3.4.4 Inspecting the cylinder assembly . . . . .	3-19
3.4.5 Assembling the tilt cylinder . . . . .	3-20
3.4.6 Installing the tilt cylinder . . . . .	3-21
<b>3.5 Hay conditioner tension cylinder, if equipped . . . . .</b>	<b>3-22</b>
3.5.1 Removing a tension cylinder . . . . .	3-22
3.5.2 Tension cylinder components . . . . .	3-23
3.5.3 Disassembling a tension cylinder . . . . .	3-24
3.5.4 Inspecting the cylinder assembly . . . . .	3-24
3.5.5 Assembling a tension cylinder . . . . .	3-25
3.5.6 Installing a tension cylinder . . . . .	3-25
<b>3.6 Accumulator, if equipped . . . . .</b>	<b>3-28</b>
3.6.1 Checking the accumulator charge pressure . . . . .	3-28
3.6.2 Charging an accumulator . . . . .	3-29
3.6.3 Discharging an accumulator . . . . .	3-30

3.6.4	Removing the accumulator . . . . .	3-32
3.6.5	Installing the accumulator . . . . .	3-33
<b>3.7</b>	<b>Hay conditioner tension valve, if equipped . . . . .</b>	<b>3-35</b>
3.7.1	Removing the tension valve . . . . .	3-35
3.7.2	Disassembling the tension valve . . . . .	3-36
3.7.3	Inspecting the tension valve . . . . .	3-36
3.7.4	Assembling the tension valve . . . . .	3-37
3.7.5	Installing the tension valve . . . . .	3-37
3.7.6	Adjusting the hay conditioner roll pressure - hydraulic adjustment . . . . .	3-38
3.7.6.1	Increasing the hay conditioner roll pressure . . . . .	3-38
3.7.6.2	Decreasing the hay conditioner roll pressure . . . . .	3-39
<b>4</b>	<b>Electrical system . . . . .</b>	<b>4-1</b>
<b>4.1</b>	<b>Basic troubleshooting information . . . . .</b>	<b>4-3</b>
4.1.1	Basic troubleshooting procedures . . . . .	4-3
4.1.2	Tools . . . . .	4-4
4.1.3	Continuity check . . . . .	4-4
4.1.4	Voltage check . . . . .	4-5
<b>4.2</b>	<b>Connectors . . . . .</b>	<b>4-6</b>
4.2.1	Checking a connector . . . . .	4-6
4.2.2	Terminal numbers . . . . .	4-6
4.2.3	Dielectric grease . . . . .	4-7
4.2.4	Pins and sockets . . . . .	4-7
4.2.5	Replacing a Packard connector . . . . .	4-8
4.2.6	Replacing an AMP connector . . . . .	4-8
<b>4.3</b>	<b>Checking the lighting . . . . .</b>	<b>4-9</b>
4.3.1	Machine lamp plug wiring diagram - North America . . . . .	4-9
<b>5</b>	<b>Flotation . . . . .</b>	<b>5-1</b>
<b>5.1</b>	<b>Header flotation . . . . .</b>	<b>5-3</b>
5.1.1	Adjusting the header flotation . . . . .	5-3
<b>5.2</b>	<b>Flotation springs . . . . .</b>	<b>5-4</b>
5.2.1	Removing the flotation springs . . . . .	5-4
5.2.2	Disassembling the flotation springs . . . . .	5-5
5.2.3	Assembling the flotation springs . . . . .	5-5
5.2.4	Installing the flotation springs . . . . .	5-5
<b>6</b>	<b>Cutterbar . . . . .</b>	<b>6-1</b>
<b>6.1</b>	<b>Lubrication . . . . .</b>	<b>6-3</b>
6.1.1	Cutterbed oil level . . . . .	6-3
6.1.2	Changing the cutterbed oil . . . . .	6-3
<b>6.2</b>	<b>Cutterbed inspection . . . . .</b>	<b>6-6</b>
<b>6.3</b>	<b>Discs . . . . .</b>	<b>6-7</b>
6.3.1	Disc maintenance . . . . .	6-7
6.3.2	Inner discs . . . . .	6-7
6.3.2.1	Removing an inner disc . . . . .	6-7
6.3.2.2	Installing an inner disc . . . . .	6-8
6.3.3	Outer discs . . . . .	6-9
6.3.3.1	Removing the outer disc . . . . .	6-9
6.3.3.2	Installing the outer disc . . . . .	6-10
<b>6.4</b>	<b>Lifters - 5 m (16 ft) header . . . . .</b>	<b>6-13</b>
6.4.1	Lifters . . . . .	6-13
6.4.2	Replacing the lifters . . . . .	6-13
<b>6.5</b>	<b>Knives . . . . .</b>	<b>6-14</b>
6.5.1	Knife wedging under disc . . . . .	6-14
6.5.2	Knife inspection . . . . .	6-14

6.5.3	Disc rotation . . . . .	6-15
6.5.4	Replacing a knife . . . . .	6-16
6.5.4.1	Cutterbed bolt torque . . . . .	6-16
6.5.5	Knife types . . . . .	6-17
6.5.6	Knife hardware inspection . . . . .	6-18
<b>6.6</b>	<b>Cutterbed . . . . .</b>	<b>6-19</b>
6.6.1	Cutterbed components . . . . .	6-19
6.6.2	Removing the cutterbed . . . . .	6-19
6.6.3	Disassembling the cutterbed . . . . .	6-21
6.6.4	Inspecting the cutterbed . . . . .	6-23
6.6.5	Assembling the cutterbed . . . . .	6-23
6.6.6	Checking the cutterbed for leaks . . . . .	6-25
6.6.7	Installing the cutterbed . . . . .	6-26
<b>6.7</b>	<b>Spindle gear assembly . . . . .</b>	<b>6-30</b>
6.7.1	Removing the spindle gear . . . . .	6-30
6.7.2	Disassembling the spindle gear . . . . .	6-31
6.7.3	Inspecting the spindle gear . . . . .	6-31
6.7.4	Assembling the spindle gear . . . . .	6-32
6.7.5	Installing the spindle gear . . . . .	6-33
<b>6.8</b>	<b>Idler gear assembly . . . . .</b>	<b>6-35</b>
6.8.1	Removing the idler gear . . . . .	6-35
6.8.2	Disassembling the idler gear . . . . .	6-36
6.8.3	Inspecting the idler gear . . . . .	6-37
6.8.4	Assembling the idler gear . . . . .	6-38
6.8.5	Installing the idler gear . . . . .	6-39
<b>7</b>	<b>Conditioner . . . . .</b>	<b>7-1</b>
<b>7.1</b>	<b>Hay conditioner adjustments . . . . .</b>	<b>7-3</b>
7.1.1	Hay conditioner . . . . .	7-3
7.1.2	Hay conditioner roll spacing . . . . .	7-3
7.1.2.1	Adjusting the hay conditioner roll spacing . . . . .	7-3
7.1.3	Adjusting the spacing indicator . . . . .	7-4
7.1.4	Hay conditioner roll pressure . . . . .	7-4
7.1.5	Adjusting the hay conditioner roll pressure - manual adjustment . . . . .	7-4
7.1.6	Adjusting the hay conditioner roll pressure-hydraulic adjustment . . . . .	7-5
7.1.6.1	Increasing the hay conditioner roll pressure . . . . .	7-5
7.1.6.2	Decreasing the hay conditioner roll pressure . . . . .	7-5
7.1.7	Adjusting the hay conditioner roll timing - 5 m (16 ft) . . . . .	7-6
7.1.8	Adjusting the hay conditioner roll timing - 4 m (13 ft) . . . . .	7-6
<b>7.2</b>	<b>Inspecting the hay conditioner rolls . . . . .</b>	<b>7-8</b>
<b>7.3</b>	<b>Top hay conditioner roll . . . . .</b>	<b>7-9</b>
7.3.1	Removing the top hay conditioner roll . . . . .	7-9
7.3.2	Installing the top hay conditioner roll . . . . .	7-13
<b>7.4</b>	<b>Bottom hay conditioner roll . . . . .</b>	<b>7-18</b>
7.4.1	Removing the bottom hay conditioner roll . . . . .	7-18
7.4.2	Installing the bottom hay conditioner roll . . . . .	7-19
<b>7.5</b>	<b>Helper roll - 4 m (13 ft) . . . . .</b>	<b>7-22</b>
7.5.1	Removing the helper roll - 4 m (13 ft) . . . . .	7-22
7.5.2	Installing the helper roll - 4 m (13 ft) . . . . .	7-25
<b>7.6</b>	<b>Helper roll - 5 m (16 ft) . . . . .</b>	<b>7-28</b>
7.6.1	Removing the helper roll - 5 m (16 ft) . . . . .	7-28
7.6.2	Installing the helper roll - 5 m (16 ft) . . . . .	7-31
<b>7.7</b>	<b>Auger stripper - 5 m (16 ft) header . . . . .</b>	<b>7-36</b>
7.7.1	Adjusting the auger strippers . . . . .	7-36
7.7.2	Replacing the auger strippers . . . . .	7-36

<b>8 Chassis</b>	8-1
<b>8.1 Strut and lift arms</b>	8-3
8.1.1 Removing the strut and lift arm	8-3
8.1.2 Disassembling the strut	8-4
8.1.3 Assembling the strut	8-5
8.1.4 Installing the strut and lift arm	8-6
<b>8.2 3-point hitch</b>	8-8
8.2.1 Removing the 3-point hitch	8-8
8.2.2 Installing the 3-point hitch	8-9
<b>8.3 Drawbar hitch</b>	8-11
8.3.1 Removing the drawbar hitch	8-11
8.3.2 Installing the drawbar hitch	8-12
<b>8.4 Tongue</b>	8-14
8.4.1 Removing the tongue	8-14
8.4.2 Inspecting the tongue	8-15
8.4.3 Installing the tongue	8-16
<b>9 Spindles and wheels</b>	9-1
<b>9.1 Installing wheels</b>	9-3
<b>9.2 Lubricating the wheel bearings</b>	9-4
<b>10 Diagrams</b>	10-1
<b>10.1 How to read wiring schematics</b>	10-3
10.1.1 Diagram numbers	10-3
10.1.2 Location grids	10-3
<b>10.2 Diagram symbols and abbreviations</b>	10-5
10.2.1 Harness and connector identification	10-5
10.2.2 Splices	10-5
10.2.3 Device identification numbers	10-5
<b>10.3 Electrical diagrams</b>	10-7
10.3.1 Harness abbreviations	10-7
10.3.2 Wire colors	10-7
10.3.3 Electrical diagram	10-9
<b>10.4 Circuit table</b>	10-11
<b>10.5 Connector table</b>	10-13
<b>10.6 Hydraulic schematic</b>	10-15
<b>11 Index</b>	Index-1





# 1. General

<b>1.1 General information</b>	<b>1-3</b>
1.1.1 Introduction to this service manual	1-3
1.1.2 Units of measurement	1-3
1.1.3 Table of contents	1-3
1.1.4 Page numbers	1-3
1.1.5 Intended use	1-3
1.1.6 Proper disposal of waste	1-3
<b>1.2 Safety</b>	<b>1-5</b>
1.2.1 Introduction	1-5
1.2.1.1 Safety alert symbol	1-5
1.2.1.2 Safety messages	1-5
1.2.1.3 Informational messages	1-5
1.2.1.4 Safety signs	1-5
1.2.1.5 A word to the operator	1-6
1.2.1.6 This manual	1-7
1.2.1.7 Operator manual holder	1-7
1.2.2 Operation	1-7
1.2.2.1 Prepare for operation	1-7
1.2.2.2 General information	1-8
1.2.2.3 Personal protective equipment	1-9
1.2.2.4 Seat instructions	1-9
1.2.2.5 Shield and guards	1-10
1.2.2.6 Exhaust warning	1-10
1.2.2.7 Flying debris	1-11
1.2.2.8 Agricultural chemicals	1-11
1.2.3 Travel on public roads	1-11
1.2.4 Maintenance	1-12
1.2.4.1 General maintenance information	1-12
1.2.4.2 Fire prevention and first aid	1-14
1.2.4.3 High pressure leaks	1-15
1.2.4.4 Accumulator safety	1-16
1.2.4.5 Replacement parts	1-16
<b>1.3 Cylinder stops</b>	<b>1-17</b>
1.3.1 Lift cylinder lockout valves	1-17
1.3.1.1 Engaging the lift cylinder lockout valves	1-17
1.3.1.2 Disengaging the lift cylinder lockout valves	1-18
1.3.2 Steering cylinder lockout valves	1-19
1.3.2.1 Engaging the steering cylinder lockout valves	1-20
1.3.2.2 Disengaging the steering cylinder lockout valves	1-20
<b>1.4 Machine identification</b>	<b>1-21</b>
1.4.1 Serial number plate	1-21
1.4.2 Tongue serial number	1-21
1.4.3 Serial number description	1-22
<b>1.5 Specifications</b>	<b>1-23</b>
1.5.1 Dimensions and weights	1-23
1.5.2 Header specifications	1-23
1.5.3 Cutterbed specifications	1-23
1.5.3.1 Cutterbed bolt torque	1-23
1.5.4 Drive system specifications	1-24
1.5.5 Tire specification	1-24

---

1.5.6	Tractor specifications . . . . .	1-24
1.5.7	Maximum roading speed . . . . .	1-24
1.5.8	Hay conditioner specifications . . . . .	1-24
1.5.9	Lubrication specifications . . . . .	1-25
<b>1.6</b>	<b>Description of a pull type rotary mower conditioner . . . . .</b>	<b>1-27</b>
1.6.1	Cutterbed . . . . .	1-27
1.6.2	Hay conditioner . . . . .	1-27
1.6.3	Swathboard . . . . .	1-27
1.6.4	Forming shields . . . . .	1-27
1.6.5	Component access . . . . .	1-28
1.6.6	Component location . . . . .	1-29
<b>1.7</b>	<b>Bearing replacement . . . . .</b>	<b>1-31</b>
1.7.1	Removing an eccentric locking collar . . . . .	1-31
1.7.2	Installing an eccentric locking collar . . . . .	1-31

---

## 1.1 General information

---

### 1.1.1 Introduction to this service manual

---

This service manual gives information from engineering tests, operating data, and the latest service techniques at the time of publication. Read this service manual carefully before doing any service on the machine.

The photos and illustrations used in this service manual were current at the time of publication. Production changes can cause machines to vary from the photos and the illustrations. The manufacturer reserves the right to redesign and change machines as necessary without notification.

**WARNING:**

**Some pictures in this manual show the machine with shields or guards removed to permit for a better view of the subject of the picture. All shields and guards must be in position before operating the machine.**

Machine movement when in normal use determines right-hand and left-hand.

---

### 1.1.2 Units of measurement

---

Measurements are given in metric units followed by the equivalent in US units. Hardware sizes are given in millimeters for metric hardware and inches for US hardware.

---

### 1.1.3 Table of contents

---

This manual has a table of contents at the front. The table of contents shows the divisions. The individual divisions also have a table of contents.

---

### 1.1.4 Page numbers

---

All pages have two numbers, such as 01-25. The first number shows the division. The second number shows the page in the division.

Page numbers occur on the lower right-hand or lower left-hand corner of each page.

---

### 1.1.5 Intended use

---

This machine is designed solely for use in customary agricultural operations.

Do not use this machine for any application or purpose other than those described in this manual. The manufacturer accepts no liability for damage or injury resulting from misuse of this machine.

Compliance with the conditions of operation, service and repair as specified by the manufacturer constitute essential elements for the intended use of this machine.

This machine should be operated, serviced and repaired only by qualified persons familiar with its characteristics and familiar with the relevant safety rules and procedures.

All generally recognized safety regulations and road traffic regulations must be obeyed at all times.

Any unauthorized modifications performed on this machine will relieve the manufacturer of all liability for any resulting damage or injury.

---

### 1.1.6 Proper disposal of waste

---

Improper disposal of waste can pollute the environment and ecology. A few examples of potentially harmful equipment waste can include, but not limited to, items such as oil, fuel, coolant, brake fluid, filters, battery chemicals, tires, etc.

Use leak proof containers when draining fluids. Do not use food or beverage containers to collect waste fluids, as food or beverage container(s) may mislead someone into drinking from them.

Do not pour or spill waste onto the ground, down a drain, or into any water source.

## *1. General*

---

Air conditioning refrigerants escaping into the air can damage the Earth's atmosphere. Government regulations may require a certified air conditioning service center to recover and recycle used air conditioning refrigerants.

Inquire with local environmental or recycling center on the proper way to recycle or dispose waste.

## 1.2 Safety

### 1.2.1 Introduction

#### 1.2.1.1 Safety alert symbol

The safety alert symbol means Attention! Become Alert! Your Safety Is Involved!

Look for the safety alert symbol both in this manual and on safety signs on this machine. The safety alert symbol will direct your attention to information that involves your safety and the safety of others.



Fig. 1

#### 1.2.1.2 Safety messages

The words DANGER, WARNING or CAUTION are used with the safety alert symbol. Learn to recognize these safety alerts and follow the recommended precautions and safety practices.



**DANGER:**

Indicates an imminently hazardous situation that, if not avoided, will result in DEATH OR VERY SERIOUS INJURY.



**WARNING:**

Indicates a potentially hazardous situation that, if not avoided, could result in DEATH OR SERIOUS INJURY.



**CAUTION:**

Indicates a potentially hazardous situation that, if not avoided, may result in MINOR INJURY.



Fig. 2

#### 1.2.1.3 Informational messages

The words important and note are not related to personal safety, but are used to give additional information and tips for operating or servicing this equipment.

**IMPORTANT:** Identifies special instructions or procedures which, if not strictly observed, could result in damage to or destruction of the machine, process, or its surroundings

**NOTE:** Identifies points of particular interest for more efficient and convenient repair or operation.

#### 1.2.1.4 Safety signs



**WARNING:**

Do not remove or obscure safety signs. Replace any safety signs that are not readable or are missing. Replacement signs are available from your dealer in the event of loss or damage. The actual location of the safety signs is illustrated at the end of this section.

Keep signs clean by wiping off regularly. Use a mild soap and water solution if necessary.

If parts have been replaced or a used machine has been purchased, make sure all safety signs are present and in the correct location and can be read. Illustrations of safety sign locations are located at the rear of this section.

Replace any safety signs that can not be read, are damaged, or are missing. Clean the machine surface thoroughly with a mild soap and water solution before replacing signs. Replacement safety signs are available from your dealer.

### 1.2.1.5 A word to the operator

It is your responsibility to read and understand the safety section in this manual and the manual for all attachments before operating this machine. Remember you are the key to safety. Good safety practices not only protect you, but also the people around you.

Study the content in this manual and make the content a working part of your safety program. Keep in mind that this safety section is written only for this type of machine. Practice all other usual and customary safe working precautions, and above all remember - safety is your responsibility. You can prevent serious injury or death.

This safety section is intended to point out some of the basic safety situations that may be encountered during the normal operation and maintenance of your machine. This section also suggests possible ways of dealing with these situations. This section is not a replacement for other safety practices featured in other sections of this manual.

Personal injury or death may result if these precautions are not followed.

Learn how to operate the machine and how to use the controls properly.

Do not let anyone operate the machine without instruction and training.

For your personal safety and the personal safety of others, follow all safety precautions and instructions found in the manuals and on safety signs affixed to the machine and all attachments.

Use only approved attachments and equipment.

Make sure your machine has the correct equipment needed by the local regulations.



**WARNING:**

**An operator should not use alcohol or drugs which can affect their alertness or coordination. An operator on prescription or 'over the counter' drugs needs medical advice on whether or not they can properly operate machines.**



Fig. 3



**CAUTION:**  
**If any attachments used on this equipment have a separate Operator Manual, see that manual for other important safety information.**

### 1.2.1.6 This manual

This manual covers general safety practices for this machine. The operator manual must always be kept with the machine.

Right-hand and left-hand, as used in this manual, are determined by facing the direction the machine will travel when in use.

The photos, illustrations, and data used in this manual were current at the time of printing, but due to possible in-line production changes, your machine can vary slightly in detail. The manufacturer reserves the right to redesign and change the machine as necessary without notification.



**WARNING:**  
**In some of the illustrations and photos used in this manual, shields or guards may have been removed for clarity. Never operate the machine with any shields or guards removed. If the removal of shields or guards is necessary to make a repair, they must be replaced before operation.**

### 1.2.1.7 Operator manual holder

The operator manual holder (1) holds the operator manual.

After using the operator manual, return the operator manual to the operator manual holder.

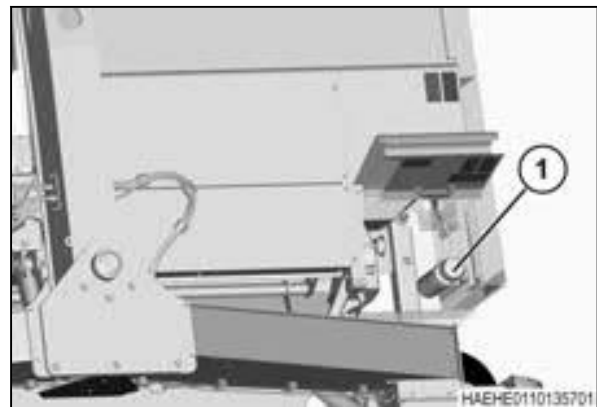

Fig. 4

## 1.2.2 Operation

### 1.2.2.1 Prepare for operation

Read and understand all operating instructions and precautions in this manual before operating or servicing the machine.

Make sure you know and understand the positions and operations of all controls. Make certain all controls are in neutral and the park brake is applied before starting the machine. Make sure the steering wheel is centered and locked.



**WARNING:**  
**Any time the engine is running and the park brake is disengaged, the machine will turn if the steering wheel is moved even though the travel control lever is in neutral.**

Make certain all people are well away from your area of work before starting and operating the machine. Check and learn all controls in an area clear of people and obstacles before starting your work. Be aware of the machine size and have enough space available to allow for operation. Never operate the machine at high speeds in crowded places.



Emphasize the importance of using correct procedures when working around and operating the machine. Do not let children or unqualified persons operate the machine. Keep others, especially children, away from your area of work. Do not permit others to ride on the machine.

Make sure the machine is in the proper operating condition as stated in the Operator Manual. Make sure the machine has the correct equipment required by local regulations.

All equipment has a limit. Make sure you understand the speed, brakes, steering, stability, and load characteristics of this equipment before you start.

### 1.2.2.2 General information

When parking, park the machine on a solid level surface and lower the header to the ground. Put all controls in neutral, center and lock the steering wheel, and apply the park brake. Stop the tractor engine and take the key with you.



**WARNING:**  
**Do not leave the machine unattended with the header raised. Lower the header fully before leaving the machine. A sudden loss of hydraulic pressure can cause the header to drop without warning.**

Make sure the machine is in the proper operating condition according to the Operator Manual.

Always operate the machine with the control console turned on.

Do not dismount from moving machinery.

Stay off slopes too steep for operation.

Be aware of the size of the machine and have enough space available to allow for operation.

Stay off slopes too steep for operation. Keep the header as low as possible while going down hills. Never suddenly reverse the wheels to stop or back up.

Where possible avoid operating the machine near ditches, embankments, and holes. Reduce ground speed when operating on rough, slippery, or muddy surfaces and when turning or crossing slopes.

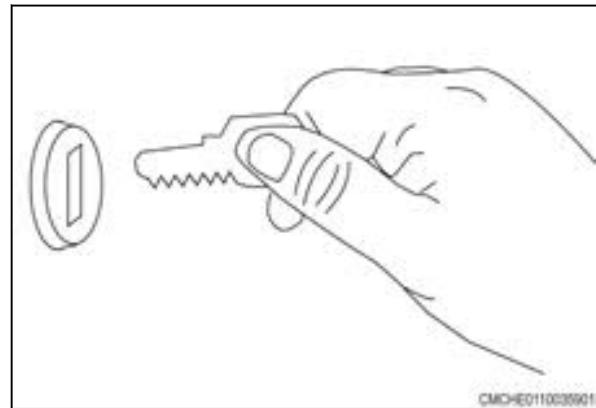

Fig. 5

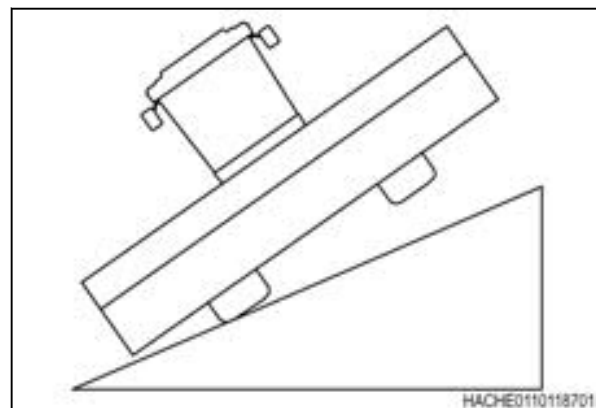

Fig. 6

Avoid contact with electrical power lines. Contact with electrical power lines can cause electrical shock, resulting in very serious injury or death.

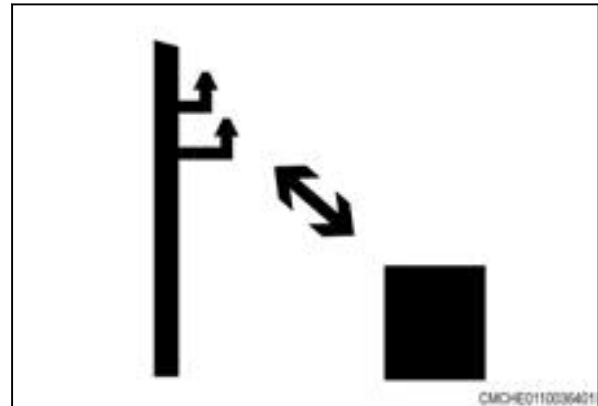

Fig. 7

### 1.2.2.3 Personal protective equipment

Wear all personal protective equipment (PPE) and protective clothing issued to you or called for by job conditions and country/local regulations. PPE includes, but is not limited to, equipment to protect eyes, lungs, ears, head, hands and feet when operating, servicing, or repairing equipment.

Always keep hands, feet, hair, and clothing away from moving parts. Do not wear loose clothing, jewelry, watches, or other items that could entangle in moving parts. Tie up long hair that can also entangle in moving parts.

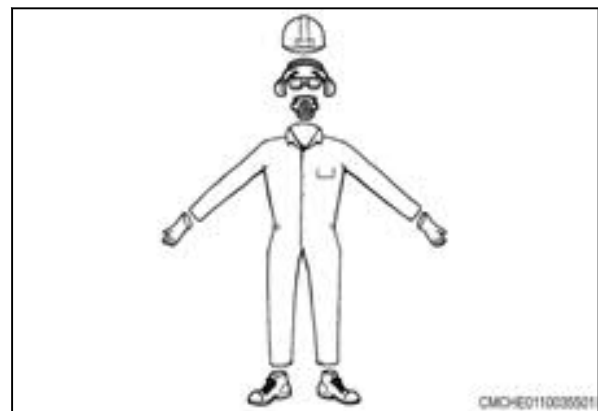

Fig. 8

### 1.2.2.4 Seat instructions

Securely fasten the seat belt before operating the machine. Always remain seated and have the seat belt fastened while operating the machine. Replace the seat belts when they become worn or broken.

Never wear a seat belt loosely or with slack in the belt system. Never wear the seat belt in a twisted condition or pinched between the seat structural members.

When using the instructional seat, if equipped, securely fasten the seat belt. The instructional seat is to be used only to train new operators or diagnose a problem. The instructional seat is only intended for short periods of use. Extra riders, especially children, are not permitted on the machine.

When the instructional seat is used the machine must be driven at a slower speed and on level ground. Avoid quick starts, stops, and sharp turns. Avoid driving on highways or public roads.

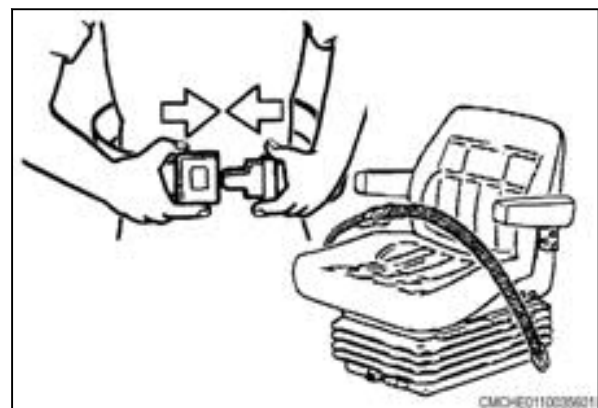

Fig. 9

### 1.2.2.5 Shield and guards

All shields and guards must be in the correct operating position and in good condition.

Do not open, remove, or reach around shields while the engine is operating. Entanglement in rotating belts and components can cause serious injury or death. Stay clear of rotating components.



Fig. 10

Do not operate the machine with the drive shaft shields open or removed. Entanglement in rotating drive shafts can cause serious injury or death. Stay clear of rotating components.

Make sure rotating guards turn freely.



Fig. 11

Do not make adjustments to the roll tension with the header engaged.

When making adjustments to the roll pressure, turn off the header. Engage the park brake.

### 1.2.2.6 Exhaust warning

Never operate the engine in a closed building unless the exhaust is vented outside.

Do not tamper with or modify the exhaust system with unapproved extensions.



Fig. 12

Thank you so much for reading.  
Please click the “Buy Now!”  
button below to download the  
complete manual.



After you pay.

You can download the most  
perfect and complete manual in  
the world immediately.

Our support email:

[ebooklibonline@outlook.com](mailto:ebooklibonline@outlook.com)