

Workshop Service Manual

Technician Service Book -

8600 series tractors

Electrical and hydraulics diagrams

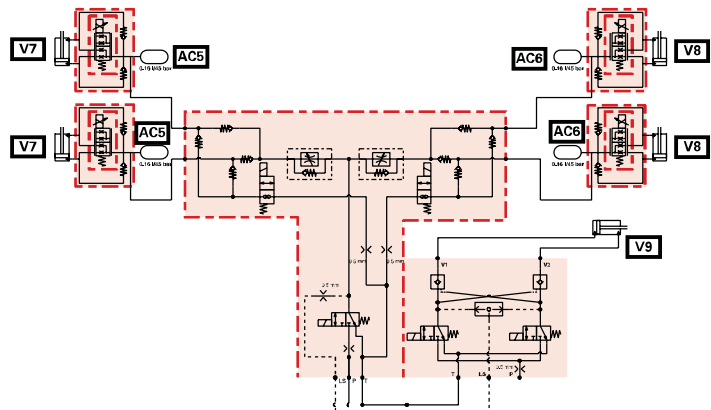
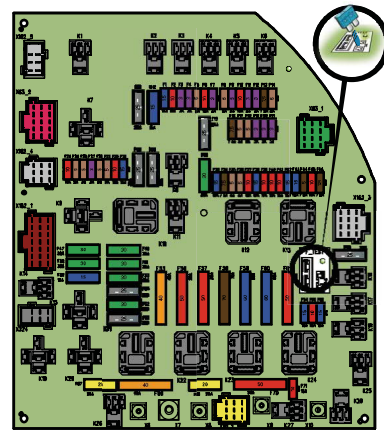

Technician Service Book - 8600 series tractors

- 1 General
 - A General
 - B Forward speeds
 - C Dimensions
 - D Capacities
 - E Retaining compounds and sealing products
- 2 Error codes
 - A Indicator light panel
 - B Error codes
- 3 Diagrams and plans
 - A Hydraulics diagrams
 - B Fuse box, electrical diagrams and harnesses
- 4 Adjustments, bleeding and calibrations
 - A Adjustments
 - B Bleeding
 - C Calibrations
- 5 Electrical display

Chapter intentionally left blank

1 - General

A	General	3
B	Forward speeds	33
C	Dimensions	41
D	Capacities	49
E	Retaining compounds and sealing products	53

A - General

1	General specifications - 8600 series tractors	5
---	---	---

1 General specifications - 8600 series tractors

Model 8650

Engine	
Brand	SISU
Type	84CTA
Nominal power (ISO TR14396) at 2200 rpm	240 hp
Maximum power (ISO TR14396) at 2000 rpm	270 hp
Maximum torque (ISO TR14396)	1185 Nm (874 lbf ft)
Nominal PTO power (OECD) at 2200 rpm	205 hp
Maximum PTO power (OECD) at PTO 1000 rpm	225 hp
Idle speed	800 rpm
Maximum speed	2260 rpm
Engine weight	665 kg (1466 lb)
Number of cylinders	6
Engine displacement (in litres)	8.4
Piston travel	145 mm (5.7 in)
Piston diameter	111 mm (4.4 in)
Compression ratio	16,7 bar (242 psi) ± 0,5 bar (7 psi)
Compression pressure	24 bar (348 psi)
Injection pump brand	Bosch
Injection pump type	CP 3.3
Firing order	1-5-3-6-2-4
Maximum pressure in the high-pressure system	1400 bar (20306 psi)
Injector brand	Bosch
Injector type	CRIN 2/8 holes
Charge pump type	Electric
Fuel prefilter filtration capacity	30 µ
Main fuel filter filtration capacity	5 µ
Low-pressure system pressure at minimum speed	0,75 bar (11 psi)
Low-pressure system pressure at maximum speed	0,75 bar (11 psi)
Recommended oil:	API CI-4 or ACEA E7
Maximum operating tilt (precautions)	-
Oil/fuel consumption	Maximum 0.1%
Lubrication system	Gear pump at the bottom of the timing
Oil cooling system	Cooler integrated into the engine (left side)
Oil pressure at minimum speed	1 bar (15 psi)
Oil pressure at maximum speed	2,5 bar (36 psi) at 5 bar (73 psi) depending on the temperature
Relief valve adjustment pressure	5 bar (73 psi) (spring pressure)
Air suction type	Turbocharged with air/air intercooler
Air preheating type	Grid heater with relay controlled by the ECU
Number of valves	24
Valve clearance value	0,35 mm (0.01 in) (inlet and exhaust)
Engine cooling system	Water cooling
Fan type	Vistronic fan

Engine	
Thermostat begins to open at	83 °C (181 °F)
Coolant temperature	-35 °C (-31 °F) to 108 °C (226 °F)
Air compressor brand for the brake system	Knorr
Type of compressor	Piston
Pressure range:	6,5 bar (94 psi) to 8 bar (116 psi)
Block preheater	110 or 220 volts
Fuel preheater	Accessory kit available
Urea preheater	Urea system and cab heating in parallel
Exhaust fumes recirculation system	Internal EGR or SCR system
Internal EGR system	Additional intake cam
SCR system (AdBlue™ or DEF injection)	Exhaust outlet treatment system
Safety system	Quality sensor in the tank
Device brand	Bosch
Type of control	Bosch controller
Main filter filtration capacity	-
Secondary filter filtration capacity	-
Tertiary filter filtration capacity	-
Urea solidification temperature	-11 °C (12 °F)
Belt: air conditioning compressor/left-hand alternator/air compressor (2 dimensions: with or without air compressor)	Poly V 6 rib belt
Belt: fan/right-hand alternator/air compressor (2 dimensions: a different fan pulley is used depending on the power)	Poly V 12 rib belt

Rear axle transmission	
Gearbox type	Continuous variation
Transmission type	ML 260
Number of ranges	2 ranges (high speed range (Hare) and low speed range (Tortoise))
Maximum speed	40 km/h (25 mile/h) or 50 km/h (31 mile/h)
Number of creeper gears	No creeper gears
Rear axle type	HA 260/HA 260F
Number of pinion/ring gear teeth	12/43
Rear axle ratio (crownwheel and pinion)	32.967
4WD ratio	0.68
Final drive type	Epicyclic
Final drive reduction ratio	9.2 (123+15/15)
Maximum 4WD clutch torque	330 daNm (2434 lbf ft)
Number of 4WD discs	8 discs/7 discs
Main brake type	10" oil-immersed disc
Number of discs	6 discs
Braking pressure	0 to 60 bar (870 psi)
Parking brake type	ParkLock (electrical/hydraulic)
Trailer brake type	Hydraulic and pneumatic
Pneumatic trailer braking pressure	6,5 bar (94 psi) to 8 bar (116 psi)

Rear axle transmission	
Hydraulic trailer braking pressure	0 to 150 bar (2176 psi)
Maximum operating tilt	25° pitch (front/rear)
	25° roll (right/left)
	17° combined
Transmission preheater	110 volts/150 watt
Total loaded weight supported by rear axle	40 km/h (25 mile/h) : 12000 kg (26455 lb)
	50 km/h (31 mile/h) : 10000 kg (22046 lb)

Front axle	
Front axle brand	DANA
Axle type	Suspended or fixed
Supplier reference	Fixed: 770/504
	Suspended: 770/618
Rotational direction	Clockwise
Front axle weight	Fixed: 765 kg (1687 lb)
	Suspended: 1066 kg (2350 lb)
Total loaded weight supported by front axle	40 km/h (25 mile/h) : 9000 kg (19841 lb)
	50 km/h (31 mile/h) : 7500 kg (16535 lb)
Recommended oil type (beam and final drive)	SAE 85 W 90 (API GL5)
Total ratio for front axle	16.862
Number of teeth on final drive	14 x 35 x 85
Final drive ratio	7.071
Number of pinion/ring gear teeth	13/31
Number of differential discs	15 discs
Maximum steering angle	55°
Oscillation angle	-
Type of oscillation stop	Mechanical
Steering ram diameter	45 mm (1.8 in) x 90 mm (3.5 in)
Steering ram stroke	2 x 143,5 mm (5.7 in)
Suspension type	Hydraulics
Suspension ram diameter	90 mm (3.5 in) x 100 mm (3.9 in)
Suspension ram stroke	100 mm (3.9 in)
Hydraulic control unit brand	Husco
Hydraulic control unit nominal pressure	200 bar (2901 psi)
Number of accumulators	2
Accumulator pressure	Left 1 l (0.3 gal (US)) : 10 bar (145 psi)
	Right 1,4 l (0.4 gal (US)) : 50 bar (725 psi)
Suspension sensor type	Angular potentiometer.
Steering sensor type	Angular potentiometer.
Brake type	Combined with the rear brake
Factor K	1.331

Electrohydraulic	
System type	Load Sensing
Flow rate	175 l/min (46.2 gal/min (US))
High-pressure pump type	Sauer Danfoss piston pump
High-pressure pump displacement	75 cm ³
High-pressure pump rotational speed	2200 rpm
High-pressure pump maximum flow rate	200 l/min (52.8 gal/min (US))
High-pressure pump maximum pressure	200 bar (2901 psi)
Maximum quantity of oil to add for heavy implements	16 l (4.2 gal (US))
Maximum exportable oil quantity (without adding oil)	64 l (16.9 gal (US))
Maximum exportable oil quantity (adding oil)	74 l (19.6 gal (US))
Charge pump type	Gravity
Main relief valve adjustment pressure	200 bar (2901 psi) ± 10 bar (145 psi)
Number of spool valves (maximum)	8
Number of front "push-pull" connectors	4 connectors i.e. 2 spool valves
Number of rear "push-pull" connectors	12 connectors i.e. 6 spool valves
Maximum flow rate per spool valve	100 l/min (26.4 gal/min (US))
Spool valve control type	Electric
Recommended oil:	According to MF CMS M1145 specification

Steering	
Steering type	Hydrostatic
Type of control	Steering wheel or steering wheel + electrohydraulic spool valves
Orbitrol displacement	315 cm ³
Steering ram diameter	90 mm (3.5 in) x 45 mm (1.8 in)
Steering ram stroke	2 x 143,5 mm (5.7 in)
Working pressure	175 bar (2538 psi) ± 5 bar (73 psi)
Pressure relief valve adjustment pressure	175 bar (2538 psi) ± 5 bar (73 psi)
Shock valve adjustment pressure	240 bar (3481 psi)
Oil recommended for steering	According to MF CMS M1145 specification

Linkage	
Rear lift ram diameter	105 mm (4.1 in)
Rear linkage travel	788 mm (31.0 in) or 860 mm (33.9 in)
Maximum lifting capacity at ball joints (rear)	10000 kg (22046 lb)
Operating pressure (rear)	180 bar (2611 psi)
3-point linkage category (rear)	3 or 4
Front lift ram diameter	100 mm (3.9 in) x 50 mm (2.0 in)
Front linkage travel	216 mm (8.5 in) ± 1,5 mm (0.06 in)
Maximum lifting capacity at ball joints (front)	5000 kg (11023 lb)
Operating pressure (front)	180 bar (2611 psi)
3-point linkage category (front)	3

Rear power take-off (PTO)	
Number of selections possible for rear PTO	540/540E/1000/1000E
Maximum permissible power 540/540E in 1"3/8 (6 and 21 splines)	100 hp
Maximum permissible power 540/540E in 1"3/4 (20 splines)	160 hp
Maximum permissible power 1000/1000E in 1"3/8 (6 and 21 splines)	180 hp
Maximum permissible power 1000/1000E in 1"3/4 (20 splines)	239 hp
Engine speed if PTO 540	2037 rpm
Engine speed if PTO 540E/1000E	1598 rpm
Engine speed if PTO 1000	2031 rpm
Rotational direction	Clockwise
Clutch type	Hydraulics
Number of clutch discs	8 discs
Control pressure	18 bar (261 psi)
Splined shaft type	6 and 21 in 1"3/8 and 20 in 1"3/4

Front power take-off	
Number of selections possible for front PTO	1000 rpm
Maximum permissible power	Clockwise: 143 hp
	Anti-clockwise: 214 hp
Maximum permissible torque	Clockwise: 507 Nm (374 lbf ft)
	Anti-clockwise: 762 Nm (562 lbf ft)
Rotational direction	2 directions of rotation
Engine speed if PTO 1000	2040 rpm
Ratio	2.04
Clutch type	Hydraulics
Splined shaft type	6 and 21 in 1"3/8

Electric	
Battery brand	TAB
Battery specifications (2 batteries)	12 V - 105 A/H
Maximum current at start-up (IEC standard)	1010 A
Starter type	12 V noseless
Starter power	4.2 kW
Alternator type	2 x 14 V/80 A (160 A) or 2 x 14 V/120 A (240 A)
Current available on ISOBUS connector	50 A

Electronics	
Function of each controller	
instrument panel	Instrument panel
Autotronic 4	Transmission
4 Autotronic 5 DC	Linkage/ParkLock/Suspended front axle/Arm-rest/Semi-active cab

Electronics	
PVG 32 valves	Electrohydraulic spool valves
Lights module	User interface for lights
Lighting controller	Lighting control
1 SISU ECM Tier 3	Engine
1 Orbitrol Danfoss valve	Orbitrol for the Auto-Guide function
Datatronic CCD	Onboard computer
Automatic air conditioning module	Air conditioning
DCU	Denoxtronic module

Cab and fittings	
Type of cab suspension available	Passive
	Semi-active
Type of rear-view mirror control available	Manual or automatic
Type of air conditioning control available	Manual or automatic
Type and brand of air conditioning compressor	SANDEN with axial pistons
Compressor displacement	154.9 cm ³ /rev.
Refrigerant	R134a
Cab noise level	71 DBA
Roof type	Standard or with window

Model 8660

Engine	
Brand	SISU
Type	84CTA
Nominal power (ISO TR14396) at 2200 rpm	265 hp
Maximum power (ISO TR14396) at 2000 rpm	295 hp
Maximum torque (ISO TR14396)	1295 Nm (955 lbf ft)
Nominal PTO power (OECD) at 2200 rpm	225 hp
Maximum PTO power (OECD) at PTO 1000 rpm	250 hp
Idle speed	800 rpm
Maximum speed	2260 rpm
Engine weight	665 kg (1466 lb)
Number of cylinders	6
Engine displacement (in litres)	8.4
Piston travel	145 mm (5.7 in)
Piston diameter	111 mm (4.4 in)
Compression ratio	16,7 bar (242 psi) ± 0,5 bar (7 psi)
Compression pressure	24 bar (348 psi)
Injection pump brand	Bosch
Injection pump type	CP 3.3
Firing order	1-5-3-6-2-4
Maximum pressure in the high-pressure system	1400 bar (20306 psi)
Injector brand	Bosch
Injector type	CRIN 2/8 holes
Charge pump type	Electric

Engine	
Fuel prefilter filtration capacity	30 μ
Main fuel filter filtration capacity	5 μ
Low-pressure system pressure at minimum speed	0,75 bar (11 psi)
Low-pressure system pressure at maximum speed	0,75 bar (11 psi)
Recommended oil:	API CI-4 or ACEA E7
Maximum operating tilt (precautions)	-
Oil/fuel consumption	Maximum 0.1%
Lubrication system	Gear pump at the bottom of the timing
Oil cooling system	Cooler integrated into the engine (left side)
Oil pressure at minimum speed	1 bar (15 psi)
Oil pressure at maximum speed	2,5 bar (36 psi) at 5 bar (73 psi) depending on the temperature
Relief valve adjustment pressure	5 bar (73 psi) (spring pressure)
Air suction type	Turbocharged with air/air intercooler
Air preheating type	Grid heater with relay controlled by the ECU
Number of valves	24
Valve clearance value	0,35 mm (0.01 in) (inlet and exhaust)
Engine cooling system	Water cooling
Fan type	Vistronic fan
Thermostat begins to open at	83 °C (181 °F)
Liquid temperature of coolant	-35 °C (-31 °F) to 108 °C (226 °F)
Air compressor brand for the brake system	Knorr
Type of compressor	Piston
Pressure range:	6,5 bar (94 psi) to 8 bar (116 psi)
Block preheater	110 or 220 volts
Fuel preheater	Accessory kit available
Urea preheater	Urea system and cab heating in parallel
Gas recycling system	Internal EGR or SCR system
Internal EGR system	Additional intake cam
SCR system (AdBlue™ or DEF injection)	Exhaust outlet treatment system
Safety system	Quality sensor in the tank
Device brand	Bosch
Type of control	Bosch controller
Main filter filtration capacity	-
Secondary filter filtration capacity	-
Tertiary filter filtration capacity	-
Urea solidification temperature	-11 °C (12 °F)
Belt: air conditioning compressor/left-hand alternator/air compressor (2 dimensions: with or without air compressor)	Poly V 6 rib belt
Belt: fan/right-hand alternator/air compressor (2 dimensions: a different fan pulley is used depending on the power)	Poly V 12 rib belt

Rear axle transmission	
Gearbox type	Continuous variation
Transmission type	ML 260
Number of ranges	2 ranges (high speed range (Hare) and low speed range (Tortoise))
Maximum speed	40 km/h (25 mile/h) or 50 km/h (31 mile/h)
Number of creeper gears	No creeper gears
Rear axle type	HA 260/HA 260F
Number of pinion/ring gear teeth	12/43
Rear axle ratio (crownwheel and pinion)	32.967
4WD ratio	0.68
Final drive type	Epicyclic
Final drive reduction ratio	9.2 (123+15/15)
Maximum 4WD clutch torque	330 daNm (2434 lbf ft)
Number of 4WD discs	8 discs/7 discs
Main brake type	10" oil-immersed disc
Number of discs	6 discs
Braking pressure	0 to 60 bar (870 psi)
Parking brake type	ParkLock (electrical/hydraulic)
Trailer brake type	Hydraulic and pneumatic
Pneumatic trailer braking pressure	6,5 bar (94 psi) to 8 bar (116 psi)
Hydraulic trailer braking pressure	0 to 150 bar (2176 psi)
Maximum operating tilt	25° pitch (front/rear) 25° roll (right/left) 17° combined
Transmission preheater	110 volts/150 watt
Total loaded weight supported by rear axle	40 km/h (25 mile/h) : 12000 kg (26455 lb) 50 km/h (31 mile/h) : 10000 kg (22046 lb)

Front axle	
Front axle brand	DANA
Axle type	Suspended or fixed
Supplier reference	Fixed: 770/504 Suspended: 770/618
Rotational direction	Clockwise
Front axle weight	Fixed: 765 kg (1687 lb) Suspended: 1066 kg (2350 lb)
Total loaded weight supported by front axle	40 km/h (25 mile/h) : 9000 kg (19841 lb) 50 km/h (31 mile/h) : 7500 kg (16535 lb)
Recommended oil type (beam and final drive)	SAE 85 W 90 (API GL5)
Total ratio for front axle	16.862
Number of teeth on final drive	14 x 35 x 85
Final drive ratio	7.071
Number of pinion/ring gear teeth	13/31
Number of differential discs	15 discs
Maximum steering angle	55°

Front axle	
Oscillation angle	-
Type of oscillation stop	Mechanical
Steering ram diameter	45 mm (1.8 in) x 90 mm (3.5 in)
Steering ram stroke	2 x 143,5 mm (5.7 in)
Suspension type	Hydraulics
Suspension ram diameter	90 mm (3.5 in) x 100 mm (3.9 in)
Suspension ram stroke	100 mm (3.9 in)
Hydraulic control unit brand	Husco
Hydraulic control unit nominal pressure	200 bar (2901 psi)
Number of accumulators	2
Accumulator pressure	Left 1 l (0.3 gal (US)) : 10 bar (145 psi) Right 1,4 l (0.4 gal (US)) : 50 bar (725 psi)
Suspension sensor type	Angular potentiometer.
Steering sensor type	Angular potentiometer.
Brake type	Combined with the rear brake
Factor K	1.331

Electrohydraulic	
System type	Load Sensing
Flow rate	175 l/min (46.2 gal/min (US))
High-pressure pump type	Sauer Danfoss piston pump
High-pressure pump displacement	75 cm ³
High-pressure pump rotational speed	2200 rpm
High-pressure pump maximum flow rate	200 l/min (52.8 gal/min (US))
High-pressure pump maximum pressure	200 bar (2901 psi)
Maximum quantity of oil to add for heavy implements	16 l (4.2 gal (US))
Maximum exportable oil quantity (without adding oil)	64 l (16.9 gal (US))
Maximum exportable oil quantity (adding oil)	74 l (19.6 gal (US))
Charge pump type	Gravity
Main relief valve adjustment pressure	200 bar (2901 psi) ± 10 bar (145 psi)
Number of spool valves (maximum)	8
Number of front "push-pull" connectors	4 connectors i.e. 2 spool valves
Number of rear "push-pull" connectors	12 connectors i.e. 6 spool valves
Maximum flow rate per spool valve	100 l/min (26.4 gal/min (US))
Spool valve control type	Electric
Recommended oil:	According to MF CMS M1145 specification

Steering	
Steering type	Hydrostatic
Type of control	Steering wheel or steering wheel + electrohydraulic spool valves
Orbitrol displacement	315 cm ³
Steering ram diameter	90 mm (3.5 in) x 45 mm (1.8 in)

Steering	
Steering ram stroke	2 x 143,5 mm (5.7 in)
Working pressure	175 bar (2538 psi) ± 5 bar (73 psi)
Pressure relief valve adjustment pressure	175 bar (2538 psi) ± 5 bar (73 psi)
Shock valve adjustment pressure	240 bar (3481 psi)
Oil recommended for steering	According to MF CMS M1145 specification

Linkage	
Rear lift ram diameter	105 mm (4.1 in)
Rear linkage travel	788 mm (31.0 in) or 860 mm (33.9 in)
Maximum lifting capacity at ball joints (rear)	10000 kg (22046 lb)
Operating pressure (rear)	180 bar (2611 psi)
3-point linkage category (rear)	3 or 4
Front lift ram diameter	100 mm (3.9 in) x 50 mm (2.0 in)
Front linkage travel	216 mm (8.5 in) ± 1,5 mm (0.06 in)
Maximum lifting capacity at ball joints (front)	5000 kg (11023 lb)
Operating pressure (front)	180 bar (2611 psi)
3-point linkage category (front)	3

Rear power take-off (PTO)	
Number of selections possible for rear PTO	540/540E/1000/1000E
Maximum permissible power 540/540E in 1"3/8 (6 and 21 splines)	100 hp
Maximum permissible power 540/540E in 1"3/4 (20 splines)	160 hp
Maximum permissible power 1000/1000E in 1"3/8 (6 and 21 splines)	180 hp
Maximum permissible power 1000/1000E in 1"3/4 (20 splines)	262 hp
Engine speed if PTO 540	2037 rpm
Engine speed if PTO 540E/1000E	1598 rpm
Engine speed if PTO 1000	2031 rpm
Rotational direction	Clockwise
Clutch type	Hydraulics
Number of clutch discs	8 discs
Control pressure	18 bar (261 psi)
Splined shaft type	6 and 21 in 1"3/8 and 20 in 1"3/4

Front power take-off	
Number of selections possible for front PTO	1000 rpm
Maximum permissible power	Clockwise: 143 hp
	Anti-clockwise: 214 hp
Maximum permissible torque	Clockwise: 507 Nm (374 lbf ft)
	Anti-clockwise: 762 Nm (562 lbf ft)
Rotational direction	2 directions of rotation
Engine speed if PTO 1000	2040 rpm

Front power take-off	
Ratio	2.04
Clutch type	Hydraulics
Splined shaft type	6 and 21 in 1"3/8

Electric	
Battery brand	TAB
Battery specifications (2 batteries)	12 V - 105 A/H
Maximum current at start-up (IEC standard)	1010 A
Starter type	12 V noseless
Starter power	4,2 kW
Alternator type	2 x 14 V/80 A (160 A) or 2 x 14 V/120 A (240 A)
Current available on ISOBUS connector	50 A

Electronics	
Function of each controller	
instrument panel	Instrument panel
Autotronic 4	Transmission
4 Autotronic 5 DC	Linkage/ParkLock/Suspended front axle/Arm-rest/Semi-active cab
PVG 32 valves	Electrohydraulic spool valves
Lights module	User interface for lights
Lighting controller	Lighting control
1 SISU ECM Tier 3	Engine
1 Orbitrol Danfoss valve	Orbitrol for the Auto-Guide function
Datatronic CCD	Onboard computer
Automatic air conditioning module	Air conditioning
DCU	Denoxtronic module

Cab and fittings	
Type of cab suspension available	Passive
	Semi-active
Type of rear-view mirror control available	Manual or automatic
Type of air conditioning control available	Manual or automatic
Type and brand of air conditioning compressor	SANDEN with axial pistons
Compressor displacement	154.9 cm ³ /rev.
Refrigerant	R134a
Cab noise level	71 DBA
Roof type	Standard or with window

Model 8670

Engine	
Brand	SISU
Type	84CTA
Nominal power (ISO TR14396) at 2200 rpm	290 hp
Maximum power (ISO TR14396) at 2000 rpm	320 hp

Thank you so much for reading.
Please click the “Buy Now!”
button below to download the
complete manual.



After you pay.

You can download the most
perfect and complete manual in
the world immediately.

Our support email:

ebooklibonline@outlook.com