

A8000
A8800

Cane Harvester

A8000 from serial PIN PRCY8000CCPA00831

A8800 from serial PIN PRCY8800CCPA00830

SERVICE MANUAL

Part number 47507541

English

April 2013

Copyright © 2013 CNH GLOBAL N.V. All Rights Reserved.

CASE IH
AGRICULTURE



SERVICE MANUAL

8000 [PRCY8000CCPA00831 -]
8800 [PRCY8800CCPA00830 -]

Contents

INTRODUCTION

| | |
|---|------|
| Engine..... | 10 |
| [10.001] Engine and crankcase | 10.1 |
| [10.114] Pump drives | 10.2 |
| [10.400] Engine cooling system | 10.3 |
| [10.250] Turbocharger and lines..... | 10.4 |
| [10.218] Fuel injection system..... | 10.5 |
| [10.254] Intake and exhaust manifolds and muffler | 10.6 |
| Front axle system | 25 |
| [25.122] Axle suspension control..... | 25.1 |
| Rear axle system..... | 27 |
| [27.120] Planetary and final drives | 27.1 |
| Hydrostatic drive..... | 29 |
| [29.218] Pump and motor components..... | 29.1 |
| [29.202] Hydrostatic transmission | 29.2 |
| Brakes and controls | 33 |
| [33.110] Parking brake or parking lock | 33.1 |
| [33.202] Hydraulic service brakes | 33.2 |
| Hydraulic systems..... | 35 |
| [35.000] Hydraulic systems..... | 35.1 |
| [35.359] Main control valve..... | 35.2 |
| [35.600] High flow hydraulics | 35.3 |
| [35.565] Cutter control circuit..... | 35.4 |
| [35.105] Charge pump..... | 35.5 |
| Frames and ballasting | 39 |
| [39.100] Frame | 39.1 |

| | |
|--|-----------|
| Steering | 41 |
| [41.216] Cylinders | 41.1 |
| [41.200] Hydraulic control components..... | 41.2 |
| [41.101] Steering control | 41.3 |
| Wheels | 44 |
| [44.511] Front wheels..... | 44.1 |
| Tracks and track suspension | 48 |
| [48.130] Track frame and driving wheels..... | 48.1 |
| [48.100] Tracks | 48.2 |
| [48.138] Track rollers | 48.3 |
| Cab climate control | 50 |
| [50.200] Air conditioning..... | 50.1 |
| Electrical systems | 55 |
| [55.510] Cab or platform harnesses and connectors..... | 55.1 |
| [55.100] Harnesses and connectors..... | 55.2 |
| [55.301] Alternator..... | 55.3 |
| [55.000] Electrical system | 55.4 |
| [55.024] Transmission control system..... | 55.5 |
| [55.405] External lighting switches and relays | 55.6 |
| [55.513] Cab transmission controls..... | 55.7 |
| [55.514] Cab lighting | 55.8 |
| [55.051] Cab Heating, Ventilation, and Air-Conditioning (HVAC) controls..... | 55.9 |
| [55.518] Wiper and washer system..... | 55.10 |
| [55.036] Hydraulic system control | 55.11 |
| [55.820] Chopping and cutting control systems | 55.12 |
| Product feeding | 60 |
| [60.370] Basecutter..... | 60.1 |
| [60.340] Topper..... | 60.2 |

| | |
|---------------------------------------|-----------|
| [60.101] Feed roll | 60.3 |
| [60.110] Feeder housing | 60.4 |
| [60.221] Crop cutter roll | 60.5 |
| [60.350] Crop divider | 60.6 |
| [60.380] Butt lifter roller | 60.7 |
| Chopping | 64 |
| [64.106] Drum | 64.1 |
| [64.160] Crop processor | 64.2 |
| Cleaning | 74 |
| [74.200] Upper extractors | 74.1 |
| [74.204] Lower extractors | 74.2 |
| Crop storage / Unloading | 80 |
| [80.420] Billet elevator | 80.1 |



INTRODUCTION

Contents

INTRODUCTION

| | |
|---|----|
| Safety rules | 3 |
| 8000, 8800 | |
| Personal safety | 5 |
| 8000, 8800 [PRCY8800CCPA00830 -] | |
| Torque | 13 |
| 8000, 8800 | |
| Special tools | 19 |
| 8000, 8800 | |
| Basic instructions Lubrication - oils and filters | 40 |
| 8000, 8800 | |
| Maintenance Chart — 50 hour maintenance | 43 |
| 8000, 8800 | |
| Maintenance Chart – 500 hours of maintenance | 44 |
| 8000, 8800 | |
| Maintenance Chart – 750 hours of maintenance | 45 |
| 8000, 8800 | |
| Maintenance Chart — 1000 hour maintenance | 46 |
| 8000, 8800 | |
| Maintenance Chart – 1500 hours of maintenance | 47 |
| 8000 INT, 8000 LA, 8800 INT, 8800 LA | |
| Maintenance Chart — 2500 hours of maintenance | 48 |
| 8000, 8800 | |
| Maintenance Chart – 3000 hours of maintenance | 49 |
| Basic instructions — 50 hour maintenance | 50 |
| 8000, 8800 [PRCY8800CCPA00830 -] | |
| Basic instructions – 250 hours of maintenance | 61 |
| 8000, 8800 [PRCY8800CCPA00830 -] | |
| Basic instructions – 500 hours of maintenance | 72 |
| 8000, 8800 [PRCY8800CCPA00830 -] | |
| Basic instructions – 750 hours of maintenance | 75 |
| 8000, 8800 [PRCY8800CCPA00830 -] | |
| Basic instructions — 1000 hour maintenance | 80 |
| 8000, 8800 [PRCY8800CCPA00830 -] | |
| Basic instructions – 1500 hours of maintenance | 81 |
| 8000, 8800 [PRCY8800CCPA00830 -] | |
| Basic instructions – 2500 hours of maintenance | 82 |
| 8000 INT, 8000 LA, 8800 [PRCY8800CCPA00830 -] | |
| Consumables | 83 |
| 8000, 8800 | |
| General specification | 84 |
| 8000, 8800 [PRCY8800CCPA00830 -] | |

Safety rules

8000, 8800

Understand that your safety and that of other people depends on you as you maintain and operate this machine. Learn about the positions and operation of all the controls before trying to operate it. **MAKE SURE YOU CHECK ALL CONTROLS IN A SAFE AREA BEFORE STARTING YOUR WORK.**

READ THIS MANUAL COMPLETELY and make sure that you understood the controls. All equipment has a limit. Make sure you understand the speed, brakes, steering stability, and load characteristics of this machine before you start to operate this machine.

The safety information given in this manual does not replace safety rules, insurance requisites, federal, state and local laws. Check that your machine has the necessary equipment required by the local laws and regulations.

We continue to work for your safety by manufacturing harvesters with better protection and supplying these rules for correct operation.

NOTICE: *This safety alert symbol indicates important safety messages in this manual. When you see this symbol, carefully read the message that follows and be alert to the possibility of personal injury or death.*

NOTICE: *Always use the safety locks on a firm level surface and properly installed prior to starting work under the machine.*

Safety Rules

- Operate controls only when seated in the operator's seat.
- A frequent cause of personal injury or death is persons falling off and being run over. Do not permit others to ride on the machine. Only one person – the operator – should be on the machine when it is in operation. See topic "Instructors seat" further on.
- **NOTICE:** *During transportation of the "A8000" harvester with tires, the operator must stop every twenty minutes and move the joystick its entire travel to realign the toe-in on the front wheels.*
- Travel speed should be such that complete control and machine stability is maintained at all times. Care must be taken when operating near ditches, embankments and holes. Reduce speed when turning, operating on slopes and on rough or muddy surfaces.
- Collision of high speed road traffic and slow moving machines can cause personal injury or death. Always use flashing lights during road travel, oversize vehicle signs, and any local laws must be followed. Pull over and let faster traffic pass. Slow down and signal before turning off.
- Always insure that brakes are operational.
- Never operate the engine in a closed building. Proper ventilation is required under all circumstances.
- Never operate the machine with shields removed.
- The "heated" coolant under pressure may spill out if the expansion tank cap is removed. Allow the system to cool down before removing the expansion tank cap.
- Hydraulic oil or diesel fuel leaking under pressure can penetrate the skin and cause infection or other injury.
To Prevent Personal Injury:
 - Relieve all pressure before disconnecting fluid lines.
 - Before applying pressure, make sure all connections are tight and components are in good condition.
 - Never use your hand to check for suspected leaks under pressure. - Use a piece of cardboard or wood for this purpose.
 - If injured by leaking fluid, see your doctor immediately.
- Battery explosion and/or damage to electrical components can result from improper connection of booster batteries or charger. Connect positive to positive and negative to negative. Externally, battery acid can cause burns and blindness and taken internally it is poison.
- It is good practice to carry two fire extinguishers on the machine. Be sure that the extinguishers are properly maintained and be familiar with their proper use.

INTRODUCTION

- Due to the flammable nature of the crop materials encountered by harvesters, fire risks are high. This hazard can be minimized by frequent removal of accumulated crop material from the machine and checking for overheated machine components. If oil leaks appear, retorque bolts or replace gaskets and seals as necessary.
- It is advisable to check all safety devices on the harvester on a weekly basis to ensure the full protection of all components.
- The machine has safety systems that should be tested periodically to ensure their correct operation.
 - Operator's seat: if not used, it turns off the harvesting functions and applies the parking brake.
 - Belt side door (right side): if open, it turns off the diesel engine and/or the start-up does not operate.
 - Level of hydraulic oil in the main tank: if below the minimum level it shuts down the diesel engine.
 - Button that inhibits the harvest functions (Yellow button).
 - Button that inhibits the operation of the diesel engine – emergency stop – (Red button).
 - Low engine oil pressure: it de-rates the diesel engine.
 - High engine temperature: it de-rates the diesel engine and shuts the engine down.

ATTENTION: *It is possible to disable the safety system for 2 min. by holding the deceleration button and starting the engine. This procedure shall be used in case of emergency only, and it is the responsibility of the machine operator. Examples of emergencies: crop fire cases, loading and unloading the harvester for transportation, personal injury cases.*

- Always make sure that the battery isolator switch is turned off while working on the harvester, for example, changing chopper blades, basecutter blades. Before welding and cleaning procedures on the machine, disconnect the battery cables.
- Always wear suitable clothing when operating or working on the machine.
- Always look above to ensure adequate clearance for elevator and topper.

ATTENTION: *The harvester has an inbuilt safety system that also inhibits the start up during certain types of maintenance.*

Personal safety

8000, 8800 [PRCY8800CCPA00830 -]

Throughout this manual and on the machine's safety decals, you will find precautionary recommendations: DANGER, WARNING, or CAUTION followed by specific instructions or two pictorial ISO safety symbols. These cautions are for your personal safety.

Failure to follow correctly the DANGER, WARNING or CAUTION instructions may result in serious injury or death.

DANGER, WARNING or CAUTION are defined as follows:

- **DANGER:** Indicates an immediate risk situation which, if not avoided, will result in death or serious injury. The color associated with Danger is RED.
- **WARNING:** Indicates a potential risk situation which, if not avoided, will result in death or serious injury. The color associated with Warning is ORANGE.
- **CAUTION:** Indicates a potential risk situation which, if not avoided, will result in minor or moderate injury. It may also be used to alert against unsafe practices. The color associated with Caution is YELLOW.

The two safety ISO pictorial symbols are defined as follows:

- The first symbol indicates the nature of the risk.
- The second symbol indicates the procedure appropriated of avoiding the risk.
- The background color is YELLOW.

Prohibition symbols, such as

 if used, are RED.

Instruction seat safety

Third parties, especially children, are not allowed in the machine.

The Instruction Seat should be only used for training of a new operator or when a technician is diagnosing a mechanical problem.

DO NOT ALLOW other people in the machine, except in the designated instructors seat, when in training.

When the Instruction Seat is occupied, the following cautions should be taken:

NOTICE: Before starting the engine make sure that the seat-belt is properly fitted. The seat belt can help to insure your safety if it is used and properly maintained. Never wear a seat belt that is not adjusted correctly. Never use a seat belt that is twisted or trapped in the seat frame.

- Drive the machine in a lower speed and on level ground.
- Avoid driving on highways or public roads.
- Avoid sudden starts and stops.
- Avoid sharp turns.
- Always use the seat-belt (1).
- Keep the cab door closed at all times.

ATTENTION: DO NOT ALLOW other people in the machine, except in the designated instructors seat and with seat belts properly fastened.

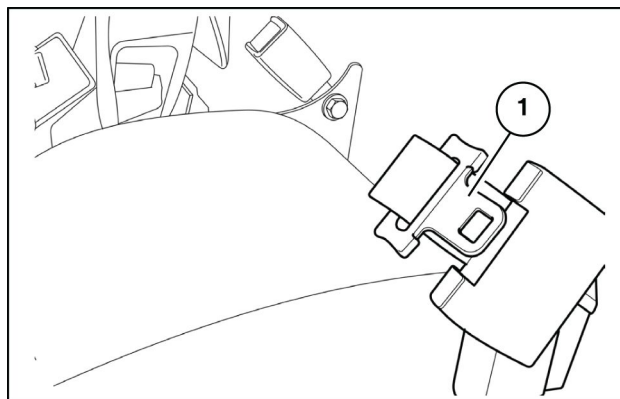

BRIL12SC0454A0A 1

Safety during maintenance

- Always keep safety and information decals clean and visible. Replace decals that are damaged, lost, painted over or cannot be read.
- When assembling, operating or servicing the machine, wear protective clothing and personal safety devices that are necessary for the particular procedure. Some safety equipments that may be necessary are protective shoes, face and/or eye protection, hard hat, heavy gloves, filter mask and hearing protection.
- DO NOT wear jewelry or loose fitting clothing that may get caught in moving parts. Always wear clothing that will not catch on objects. Keep hands, feet, clothing and hair away from moving parts.
- Never attempt to clear obstructions or objects from the machine while the engine is running.
- Always switch off the engine and remove the ignition switch when going out from the operator's seat or of the machine.
- To carry out maintenance on the machine, always position it on a flat, firm surface. When you remove or open guards for maintenance, always put them back before operating the machine. Never operate the machine with the guards opened, or without them.
- Keep the area used to maintenance clean and dry. Wet or oily floors are slippery. Wet spots can be dangerous when working with electrical equipment. Be sure all electrical outlets and tools are properly grounded.

ATTENTION: BEFORE PERFORMING ANY MAINTENANCE PROCEDURE USING WELDING, ALWAYS DISCONNECT THE BATTERY CABLES, WITH THE NEGATIVE POLE FIRST. WHENEVER POSSIBLE, REMOVE THE PART TO BE WELDED FROM THE HARVESTER AND PERFORM WELDING WITH THE PART DISASSEMBLED. IF IT IS NOT POSSIBLE TO DO SO, CONTACT YOUR CASE IH DEALER FOR RECOMMENDATIONS ON THE CORRECT PROCEDURE IN ORDER TO AVOID DAMAGE TO ELECTRICAL AND ELECTRONIC PARTS, BEARINGS, AND OTHER ITEMS.

Procedure for using the safety locks

When performing any maintenance procedures on the harvester, it is mandatory to use the safety locks (1).

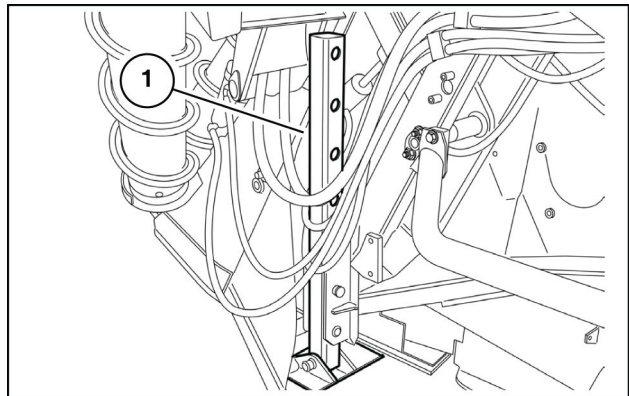

BRIL12SC0455A0A 2

To use the safety locks, the harvester must be raised to the proper height to allow lowering the locks (1) on a firm and flat surface.

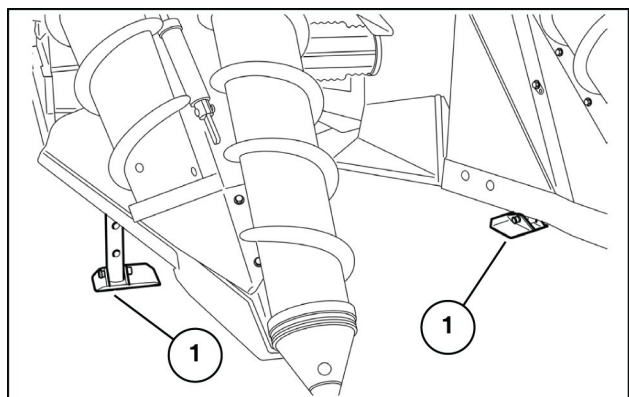

BRIL12SC0456A0A 3

When supporting the locks and before going under the harvester, make sure that the pins (1) are properly installed into the lock holes.

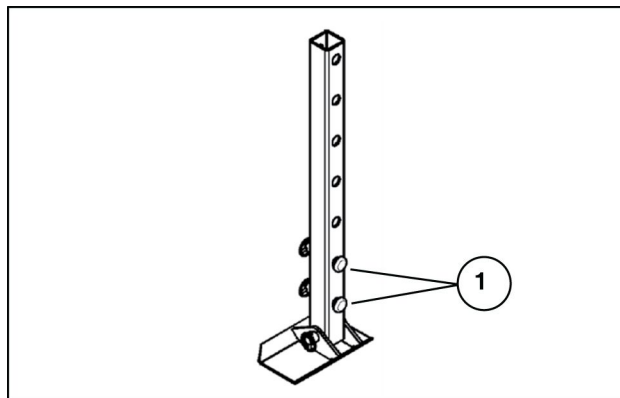

BRIL12SC0457A0A 4

ATTENTION: ON WET AND/OR SOFT GROUND THE LOCKS CAN DEEPEN IN, THUS LOWERING THE HARVESTER. LOOK FOR A PROPER SURFACE TO SAFELY SUPPORTING THE LOCKS.

ATTENTION: BEFORE OPERATING THE HARVESTER, ALWAYS MAKE SURE THE SAFETY LOCKS ARE RETRACTED WITH THE PINS PROPERLY INSTALLED

Safety against fire

- Fire risks can be minimized by the frequent cleaning of material accumulated of the harvest or residues of the machine.
- Remove daily material of the harvest or residues of the machine. Especially check the engine area and exhaust system.
- Engine fuel can cause an explosion or fire. DO NOT fuel the tank with the engine running, or if close to fire, welding, smoking, etc.

Refer to the Prevention Against Fire in the Maintenance Section of this manual for additional information.

Battery safety

- DO NOT CREATE sparks or flame next to the battery.
- When disconnecting battery terminals, remove the Negative (-) cable first; then remove the Positive (+). When connecting the cables, connect first the Positive (+), then the Negative (-).
- Disconnect the battery (both terminals) before welding on any part of the machine. Not taking this precaution can cause damage to sensitive electric components.
- BATTERY ACID CAUSES SERIOUS BURNS. Batteries contain sulfuric acid. Avoid contact with skin, eyes, or clothing. Antidote: EXTERNAL - Flush with water. INTERNAL – Drink large quantities of water or milk. DO NOT induce vomiting. Seek medical attention immediately. EYES - Flush with water for **15 min** and immediately visit a doctor. BATTERIES PRODUCE EXPLOSIVE GASES. Keep all open flames, sparks and cigarettes away. Ventilate when loading or using in enclosed space. Always use eye protection when working near batteries. Always wash your hands after handling. KEEP OUT OF REACH OF CHILDREN.
- When working near stored batteries, remember that exposed parts of metal are conductors. Never place a metal object on the terminals because it can cause a spark, short circuit, explosion or personal injury.
- Battery posts, terminals and other related accessories contain lead and lead compounds. Always wash your hands after handling.

Safety in machine operation

- DO NOT allow other people to hitch a ride on the machine. They may fall or cause an accident.
- DO NOT operate the machine while under the influence of alcohol or drugs.
- Be alert and always know the location of all the workers in your area. Keep other people out of the way of your machine. Injury or death can result if you do not follow these instructions.
- Keep away of dangerous areas as ditches and inclines. Walk through the working location before starting and note the dangers.

Hazardous chemicals

- Whether you are exposed or come into contact with dangerous chemical products, you can be seriously injured. The fluids, lubricants, paints, adhesives, coolants, etc., used in your machine can be hazardous.
- Material Safety Data Sheets (MSDS) provide information about the chemical substances within a product, safe handling procedures, first aid measures and procedures to be taken when the product is accidentally leaked. MSDS are available in your Case IH Dealer.
- Before carrying out maintenance or service on your machine, check MSDS for each fluid, lubricant, etc., used. This information indicates the risks and how to carry out the maintenance in a safe manner. Follow this information when servicing the machine.
- Before servicing this machine and before discarding used fluid and lubricants, always remember the environment. DO NOT put oil or fluids into the ground or into containers that can leak.
- Check with the local authority of environmental protection or recycling, or with your dealer, the correct procedure for disposal.

Safety precautions

Most farm machinery accidents can be avoided by observing a few simple precautions. To avoid accidents, read carefully the instructions below before you operate the harvester. Farm machinery should only be operated by responsible, mature and skilled people.

Operation

- The machine should be operated by trained personnel who are familiar with all the controls, commands and harvest techniques, and on slopes with up to 10% gradient for harvesters with tires (A8000). Operation of equipment you are not familiar with may lead to a serious accident.
- The machine should be operated by trained personnel who are familiar with all the controls, commands and harvest techniques, and on slopes with up to 15% gradient for track harvesters (A8800) . Operation of equipment you are not familiar with may lead to a serious accident.
- When driving on public roads:
 - Note traffic regulations.
 - Adapt your speed to road and traffic conditions and ensure that all lights and other safety mechanisms on the machine (if they are required) are fitted and work properly.
 - Ensure that both brake pedals are locked together when traveling on public roads. (A8000).
- Do not permit anyone other than the operator to ride on the harvester.
- Do not brake abruptly to avoid tipping of the machine.
- Before moving the machine, check if all the shields are closed and locked in the position.
- Before starting the engine, ensure everyone is clear of the harvester.
- Keep children away from and off the harvester at all times.
- Every day, check the torque of the front and rear wheels (A8000) of the guide wheel (A8800) .
- Do not attempt to clean, lubricate or carry out any adjustments on the harvester while it is in motion or while the engine is running.
- For safety's sake never leave the operator's platform without first disengaging the harvester drive mechanism, stopping the engine, applying the parking brake and removing the starting key.
- Do not go under the machine before the maintenance safety locks have been securely installed.
- Do not work around the machine in loose clothing that might catch in any of the moving parts.
- Keep hands away from moving parts of the machine
- Keep the loaded fire extinguisher within reach of the operator and inside the validity period.
- Do not try to go up over the cab.

Engine

- Keep engine area clean of dust, trash and straw to prevent the possibility of fires.
- Never idle the harvester in an enclosed area as harmful exhaust gases may build up and cause death.
- Exercise care when removing the radiator cap while the engine is hot. If you cannot wait until the engine has cooled, cover the cap with a rag and turn it slowly to the first stop to allow the pressure to escape before removing the cap completely. NEVER add cold water to a hot radiator. If the expansion tank cap is lost, always replace it with an original Case IH cap. A non-approved cap may not be safe.
- The fuel oil in the injection system is under high pressure and fuel oil leaks can penetrate the skin. Do not attempt to remove or adjust a fuel injection pump, injectors or nozzles.
- Prolonged contact with used engine oil may affect your skin. Protect your skin by wearing rubber gloves.
- Be very careful to avoid contact with hot engine oil. If the engine oil is extremely hot, allow the oil to cool to a moderately warm temperature for safe removal.
- Do not handle a hot oil filter with bare hands.
- The engine oil pressure should be within normal limits.
- If engine oil pressure is above normal limits it should be checked if the oil filter is clogged or if the oil gallery is obstructed. See your CASE IH dealer.

Turbocharger

- Run the engine at idle speed for 3 to 5 minutes before running it with load.
- Once you have started and idled the engine, gradually increase the engine speed to enable lubrication of the bearings stabilization of the lubricant oil pressure.
- DO NOT increase engine speed just after it has been started, because the turbo reaches a very high speed and it can be damaged and, consequently, may cause damage to the engine.
- DO NOT increase engine speed just before turning off the engine, as it causes the oil pressure to drop suddenly in the bearings when the shaft is still spinning at high speed.
- Both conditions above will cause the bearings and shaft to overheat and wear, leading the turbo to a long-term failure.

Diesel fuel

- Never remove the tank cap nor fill it up while the engine is running or hot.
- Do not smoke or use a naked flame when refueling or when standing near fuel tanks.
- Do not fill the tank completely; allow some space for expansion.
- Wipe up spilled fuel immediately.
- Always keep the tank cap firmly tightened.
- If the original fuel tank cap is lost, replace it with a CASE IH approved cap. A non-approved, proprietary cap may not be safe.
- Never use fuel for cleaning purposes.
- Keep equipment clean and properly maintained.
- Do not drive the harvester near open fires.
- Keep the screen (filter) inside the filler neck during the fueling.

Fire extinguisher

It is recommended maintaining a fire extinguisher in the harvesters when it is operating to help to control fires.

NOTICE: *It is essential that the extinguishers receive adequate maintenance and that the operator receives instructions of how to use it.*

Monthly checks

1. Check if the extinguisher is in the validity period.
2. Check if the pressure indicator is in the green band.
3. Check that the seals are intact.
4. Check if there is the INMETRO conformity mark.
5. Check if the durability and validity terms of the hydrostatic test are not expired.
6. Check if the external general appearance is in good condition (without any corrosion, dents and other damages).

ATTENTION: If any of the items above are not correct, replace the extinguisher.

Safety precautions

1. Do not test the extinguisher, any use will cause pressure loss, making it inoperative.
2. Involuntary contact with residue of the extinguisher agent can cause irritation to the skin, eyes and breathing passages.
3. If you are in physical discomfort, seek medical attention.
4. Contents under pressure. Never perforate, dent, or expose to a flame after discharged.

Extinguisher specification

Extinguishing capacity: 2A: 20-B: C

Fire class: ABC

Load: 4 kg

Extinguishing agent: Monoammonium Phosphate

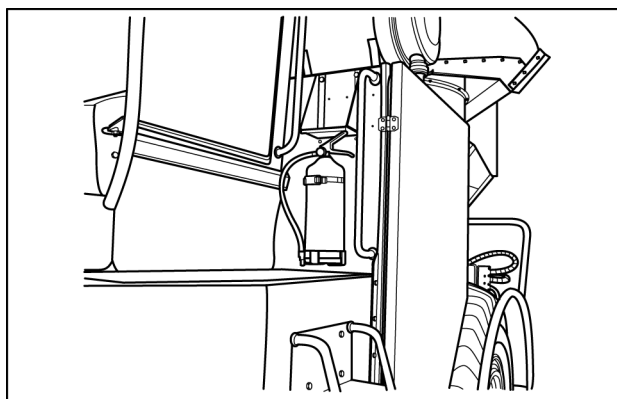

BRIL12SC0458A0A 5

Operation and use instructions

The user should have minimum knowledge for the correct utilization of the product. The basic sequence of operation is shown in the instructions chart (label) of the extinguisher.

The information to follow is complementary and can be used for users' training:

1. Remove the extinguisher from the fixing bracket.
2. Press the trigger and move the jet in an arc. If the fuel is liquid, do not apply the jet directly over the surface to avoid increasing the burning area.
3. When the fire is extinguished, be alert to a possible reigniting. Only ABC powders can provide reasonable assurance in preventing inflammable solids from reigniting.
4. Evacuate and ventilate the area. The smoke is always toxic and could cause irritation to the respiratory system or even lead to the loss of consciousness.

NOTICE: The discharge time for powder extinguishers is short. Due to the short duration of the discharge, the operator should be alert regarding wasting extinguisher agent.

Combating fires in liquid fuels (Class B) should be accomplished with continuous discharge of the spray.

For solid fuels (Class A), depending on the proportions of the fire, the use of intermittent discharge may be necessary.

Safety decals

NOTICE: If the old decals are damaged, lost, painted or can't be read replace them. When replacing components that have decals fitted, make sure to place a new decal in each new part. Keep the decals clean. When you clean the decals, use only a cloth, water and soap. Do not use solvents, gasoline, etc.

NOTE: New decals are available in your Case IH Dealer.

ATTENTION: Lower the basecutter when parking the machine.

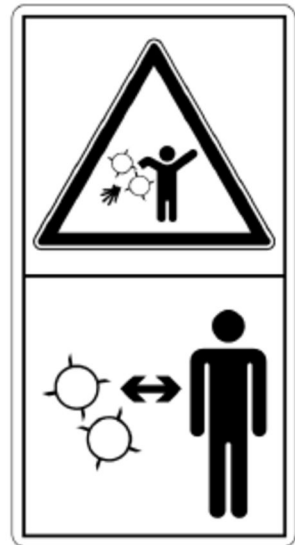



| | |
|----------------------------|--|
| CAUTION | MACHINES FITTED WITH CABIN HEATER |
| RADIATOR FILL PROCEDURE | AT INITIAL FILL OR AFTER DRAINING RADIATOR FILL AND BLEED HEATER COIL IN CAB ROOF WITH ENGINE RUNNING TO REMOVE AIR FROM SYSTEM |



Torque



8000, 8800

Torque specification – fasteners Metric



Use the torques shown in this table whenever the specified torques is not indicated.

These torques are used for fasteners with UNC and UNF threads, when they are supplied dried (non-lubricated) by the suppliers or when they are lubricated with engine oil. Not applicable if special graphite, molybdenum disulphide grease or other lubricants for extreme pressure are used.

Grade 5 bolts, screws, and stud bolts

| Size | lb in/lb ft | Nm |
|---|---|---|
|  |  |  |
| 1/4 in | 108 - 132 lb in | 12 - 15 N·m |
| 5/16 in | 204 - 252 lb in | 23 - 28 N·m |
| 3/8 in | 420 - 504 lb in | 48 - 57 N·m |
| 7/16 in | 54 - 64 lb ft | 73 - 87 N·m |
| 1/2 in | 80 - 96 lb ft | 109 - 130 N·m |
| 9/16 in | 110 - 132 lb ft | 149 - 179 Nm |
| 5/8 in | 150 - 180 lb ft | 203 - 244 Nm |
| 3/4 in | 270 - 324 lb ft | 366 - 439 Nm |
| 7/8 in | 400 - 480 lb ft | 542 - 651 Nm |
| 1 in | 580 - 696 lb ft | 787 - 944 Nm |
| 1-1/8 in | 800 - 880 lb ft | 1085 - 1193 Nm |
| 1-1/4 in | 1120 - 1240 lb ft | 1519 - 1681 Nm |
| 1-3/8 in | 1460 - 1680 lb ft | 1980 - 2278 Nm |
| 1-1/2 in | 1940 - 2200 lb ft | 2631 - 2983 Nm |

Grade 8 bolts, screws and stud bolts

| Size | lb in/lb ft | Nm |
|---|---|---|
|  |  |  |
| 1/4 in | 144 - 180 lb in | 16 - 20 Nm |
| 5/16 in | 288 - 348 lb in | 33 - 39 Nm |
| 3/8 in | 540 - 648 lb in | 61 - 73 Nm |
| 7/16 in | 70 - 84 lb ft | 95 - 114 Nm |
| 1/2 in | 110 - 132 lb ft | 149 - 179 Nm |
| 9/16 in | 160 - 192 lb ft | 217 - 260 Nm |
| 5/8 in | 220 - 264 lb ft | 298 - 358 Nm |
| 3/4 in | 380 - 456 lb ft | 515 - 618 Nm |
| 7/8 in | 600 - 720 lb ft | 814 - 976 Nm |
| 1 in | 900 - 1080 lb ft | 1220 - 1465 Nm |
| 1-1/8 in | 1280 - 1440 lb ft | 1730 - 1953 Nm |
| 1-1/4 in | 1820 - 2000 lb ft | 2468 - 2712 Nm |
| 1-3/8 in | 2380 - 2720 lb ft | 3227 - 3688 Nm |
| 1-1/2 in | 3160 - 3560 lb ft | 4285 - 4827 Nm |

NOTE: Use thick nuts with Grade 8 bolts.

Torque specifications – Metric fasteners

Use the following torque values when torque specifications are not indicated.

These values are used for metric threaded fasteners, in the way they are received from the suppliers, plated or not, or when they are lubricated with engine oil. These values are not applicable if graphite or molybdenum disulphide grease or oil is used.

Grade 8.8 bolts, screws and stud bolts

| Size | lb in/lb ft | Nm |
|---|-------------------|----------------|
|  | | |
| M4 | 24 - 36 lb in | 3 - 4 Nm |
| M5 | 60 - 72 lb in | 7 - 8 Nm |
| M6 | 96 - 108 lb in | 11 - 12 Nm |
| M8 | 228 - 276 lb in | 26 - 31 Nm |
| M10 | 456 - 540 lb in | 52 - 61 Nm |
| M12 | 66 - 79 lb ft | 90 - 107 Nm |
| M14 | 106 - 127 lb ft | 144 - 172 Nm |
| M16 | 160 - 200 lb ft | 217 - 271 Nm |
| M20 | 320 - 380 lb ft | 434 - 515 Nm |
| M24 | 500 - 600 lb ft | 675 - 815 Nm |
| M30 | 920 - 1100 lb ft | 1250 - 1500 Nm |
| M36 | 1600 - 1950 lb ft | 2175 - 2600 Nm |

INTRODUCTION

Grade 10.9 bolts, screws and stud bolts

| Size | lb in/lb ft | Nm |
|---|-------------------|----------------|
|  | | |
| M4 | 36 - 48 lb in | 4 - 5 Nm |
| M5 | 84 - 96 lb in | 9 - 11 Nm |
| M6 | 132 - 156 lb in | 15 - 18 Nm |
| M8 | 324 - 384 lb in | 37 - 43 Nm |
| M10 | 54 - 64 lb ft | 73 - 87 Nm |
| M12 | 93 - 112 lb ft | 125 - 150 Nm |
| M14 | 149 - 179 lb ft | 200 - 245 Nm |
| M16 | 230 - 280 lb ft | 310 - 380 Nm |
| M20 | 450 - 540 lb ft | 610 - 730 Nm |
| M24 | 780 - 940 lb ft | 1050 - 1275 Nm |
| M30 | 1470 - 1770 lb ft | 2000 - 2400 Nm |
| M36 | 2580 - 3090 lb ft | 3500 - 4200 Nm |

Grade 12.9 bolts, screws and stud bolts

| | | |
|--|--|--|
|  | | |
| Usually the torque values specified for grade 10.9 fasteners can be used satisfactorily on grade 12.9 fasteners. | | |

Torque specifications – Steel hydraulic fittings

Connection with grade 37 dilation

| Tube external diameter/Hose internal diameter | | Thread size | lb in/lb ft | Nm |
|---|----------|--------------|-----------------|--------------|
| mm | inch | | | |
| 6.4 mm | 1/4 in | 7/16-20 in | 72 - 144 lb in | 8 - 16 Nm |
| 7.9 mm | 5/16 in | 1/2-20 in | 96 - 192 lb in | 11 - 22 Nm |
| 9.5 mm | 3/8 in | 9/16-18 in | 120 - 300 lb in | 14 - 34 Nm |
| 12.7 mm | 1/2 in | 3/4-16 in | 180 - 504 lb in | 20 - 57 Nm |
| 15.9 mm | 5/8 in | 7/8-14 in | 300 - 696 lb in | 34 - 79 Nm |
| 19.0 mm | 3/4 in | 1-1/16-12 in | 77 - 82 lb ft | 104 - 111 Nm |
| 22.2 mm | 7/8 in | 1-3/16-12 in | 90 - 100 lb ft | 122 - 136 Nm |
| 25.4 mm | 1 in | 1-5/16-12 in | 110 - 120 lb ft | 149 - 163 Nm |
| 31.8 mm | 1-1/4 in | 1-5/8-12 in | 140 - 150 lb ft | 190 - 204 Nm |
| 38.1 mm | 1-1/2 in | 1-7/8-12 in | 225 - 240 lb ft | 305 - 325 Nm |

Split flange mounting bolts

| Size | lb in/lb ft | Nm |
|------------|-----------------|--------------|
| 5/16-18 in | 180 - 240 lb in | 20 - 27 Nm |
| 3/8-16 in | 240 - 300 lb in | 27 - 34 Nm |
| 7/16-14 in | 420 - 540 lb in | 47 - 61 Nm |
| 1/2-13 in | 55 - 65 lb ft | 74 - 88 Nm |
| 5/8-11 in | 140 - 150 lb ft | 190 - 203 Nm |

INTRODUCTION

Straight threads with an O-ring

| Tube external diameter/Hose internal diameter | | Thread size | lb in/lb ft | Nm |
|---|----------|--------------|-----------------|--------------|
| mm | inch | | | |
| 6.4 mm | 1/4 in | 7/16-20 in | 144 - 228 lb in | 16 - 26 Nm |
| 7.9 mm | 5/16 in | 1/2-20 in | 192 - 300 lb in | 22 - 34 Nm |
| 9.5 mm | 3/8 in | 9/16-18 in | 300 - 480 lb in | 34 - 54 Nm |
| 12.7 mm | 1/2 in | 3/4-16 in | 540 - 804 lb in | 57 - 91 Nm |
| 15.9 mm | 5/8 in | 7/8-14 in | 58 - 92 lb ft | 79 - 124 Nm |
| 19.0 mm | 3/4 in | 1-1/16-12 in | 80 - 128 lb ft | 108 - 174 Nm |
| 22.2 mm | 7/8 in | 1-3/16-12 in | 100 - 160 lb ft | 136 - 216 Nm |
| 25.4 mm | 1 in | 1-5/16-12 in | 117 - 187 lb ft | 159 - 253 Nm |
| 31.8 mm | 1-1/4 in | 1-5/8-12 in | 165 - 264 lb ft | 224 - 357 Nm |
| 38.1 mm | 1-1/2 in | 1-7/8-12 in | 250 - 400 lb ft | 339 - 542 Nm |

Torque specifications - Hydraulic steel O-ring fittings

Face sealing end with an O-ring

| SAE nominal size | Tube outside diameter | | Thread size | lb in/lb ft | Nm |
|------------------|-----------------------|----------|---------------|-----------------|--------------|
| | mm | inch | | | |
| -4 | 6.4 mm | 1/4 in | 9/16-18 in | 120 - 144 lb in | 14 - 16 Nm |
| -6 | 9.5 mm | 3/8 in | 11/16-16 in | 216 - 240 lb in | 24 - 27 Nm |
| -8 | 12.7 mm | 1/2 in | 13/16-16 in | 384 - 480 lb in | 43 - 54 Nm |
| -10 | 15.9 mm | 5/8 in | 1-14 in | 552 - 672 lb in | 62 - 76 Nm |
| -12 | 19.0 mm | 3/4 in | 1-3/16-12 in | 65 - 70 lb ft | 90 - 95 Nm |
| -14 | 22.2 mm | 7/8 in | 1-3/16-12 in | 65 - 70 lb ft | 90 - 95 Nm |
| -16 | 25.4 mm | 1.0 in | 1-7/16-12 in | 92 - 100 lb ft | 125 - 135 Nm |
| -20 | 31.8 mm | 1-1/4 in | 1-11/16-12 in | 125 - 140 lb ft | 170 - 190 Nm |
| -24 | 38.1 mm | 1-1/2 in | 2-12 in | 150 - 165 lb ft | 200 - 225 Nm |

O-Ring end with protrusion

Self-locking nut or fitting

| SAE nominal size | Tube outside diameter | | Thread size | lb in/lb ft | Nm |
|------------------|-----------------------|----------|---------------|-----------------|--------------|
| | mm | inch | | | |
| -4 | 6.4 mm | 1/4 in | 7/16-20 in | 204 - 240 lb in | 23 - 27 Nm |
| -6 | 9.5 mm | 3/8 in | 9/16-18 in | 300 - 360 lb in | 34 - 41 Nm |
| -8 | 12.7 mm | 1/2 in | 3/4-16 in | 540 - 600 lb in | 61 - 68 Nm |
| -10 | 15.9 mm | 5/8 in | 7/8-14 in | 35 - 40 lb ft | 47 - 54 Nm |
| -12 | 19.0 mm | 3/4 in | 1-1/16-12 in | 60 - 70 lb ft | 81 - 95 Nm |
| -14 | 22.2 mm | 7/8 in | 1-13/16-12 in | 70 - 80 lb ft | 95 - 109 Nm |
| -16 | 25.4 mm | 1.0 in | 1-5/16-12 in | 80 - 90 lb ft | 108 - 122 Nm |
| -20 | 31.8 mm | 1-1/4 in | 1-5/8-12 in | 95 - 115 lb ft | 129 - 156 Nm |
| -24 | 38.1 mm | 1-1/2 in | 1-7/8-12 in | 120 - 140 lb ft | 163 - 190 Nm |

Thank you so much for reading.
Please click the “Buy Now!”
button below to download the
complete manual.



After you pay.

You can download the most
perfect and complete manual in
the world immediately.

Our support email:

ebooklibonline@outlook.com