

**Patriot® 2240**  
Sprayer

**SERVICE MANUAL**

**Part number 47581111**  
1<sup>st</sup> edition English  
July 2013



# Link Product / Engine

---

<b>Product</b>	<b>Market Product</b>	<b>Engine</b>
Patriot 2240	North America	F4HFE6138*A002

# Contents

---

## INTRODUCTION

Engine.....	10
[10.001] Engine and crankcase .....	10.1
[10.310] Aftercooler.....	10.2
[10.400] Engine cooling system .....	10.3
[10.500] Selective Catalytic Reduction (SCR) exhaust treatment.....	10.4
Front axle system .....	25
[25.100] Powered front axle .....	25.1
[25.122] Axle suspension control.....	25.2
[25.310] Final drives .....	25.3
Rear axle system.....	27
[27.100] Powered rear axle.....	27.1
[27.120] Planetary and final drives .....	27.2
Hydrostatic drive.....	29
[29.218] Pump and motor components.....	29.1
Power Take-Off (PTO).....	31
[31.220] Gearbox.....	31.1
Brakes and controls .....	33
[33.110] Parking brake or parking lock .....	33.1
[33.202] Hydraulic service brakes .....	33.2
Hydraulic systems.....	35
[35.000] Hydraulic systems.....	35.1
[35.104] Fixed displacement pump.....	35.2
[35.106] Variable displacement pump .....	35.3
[35.300] Reservoir, cooler, and filters.....	35.4
[35.911] Sprayer boom hydraulic system.....	35.5

<b>Steering</b> .....	<b>41</b>
[41.101] Steering control .....	41.1
[41.216] Cylinders .....	41.2
<b>Wheels</b> .....	<b>44</b>
[44.511] Front wheels.....	44.1
[44.520] Rear wheels.....	44.2
<b>Cab climate control</b> .....	<b>50</b>
[50.200] Air conditioning .....	50.1
<b>Electrical systems</b> .....	<b>55</b>
[55.019] Hydrostatic drive control system .....	55.1
[55.100] Harnesses and connectors.....	55.2
[55.988] Selective Catalytic Reduction (SCR) electrical system .....	55.3
[55.DTC] FAULT CODES.....	55.4
<b>Spraying</b> .....	<b>78</b>
[78.111] Spraying pump .....	78.1
<b>Platform, cab, bodywork, and decals</b> .....	<b>90</b>
[90.105] Machine shields and guards .....	90.1



# INTRODUCTION

# Contents

---

## INTRODUCTION

Safety rules .....	3
Personal safety - Do not operate tag .....	4
Safety rules .....	5
Basic instructions - Ecology and the environment .....	13
Basic instructions - Important notice regarding equipment servicing .....	14
Basic instructions - Shop and assembly .....	15
Basic instructions .....	17
Torque - Minimum tightening torques for normal assembly .....	18
Torque - Standard torque data for hydraulics .....	21
Definition - Important notice regarding equipment servicing .....	23
Capacities - Lubricants and capacities .....	24
General specification - Machine orientation .....	25

## Safety rules

### Personal safety





This is the safety alert symbol. It is used to alert you to potential personal injury hazards. Obey all safety messages that follow this symbol to avoid possible death or injury.

Throughout this manual you will find the signal words DANGER, WARNING, and CAUTION followed by special instructions. These precautions are intended for the personal safety of you and those working with you.

Read and understand all the safety messages in this manual before you operate or service the machine.

 DANGER indicates a hazardous situation that, if not avoided, will result in death or serious injury.

 WARNING indicates a hazardous situation that, if not avoided, could result in death or serious injury.

 CAUTION indicates a hazardous situation that, if not avoided, could result in minor or moderate injury.

**FAILURE TO FOLLOW DANGER, WARNING, AND CAUTION MESSAGES COULD RESULT IN DEATH OR SERIOUS INJURY.**

### Machine safety

**NOTICE:** Notice indicates a situation that, if not avoided, could result in machine or property damage.

Throughout this manual you will find the signal word Notice followed by special instructions to prevent machine or property damage. The word Notice is used to address practices not related to personal safety.

### Information

**NOTE:** Note indicates additional information that clarifies steps, procedures, or other information in this manual.

Throughout this manual you will find the word Note followed by additional information about a step, procedure, or other information in the manual. The word Note is not intended to address personal safety or property damage.

## Personal safety - Do not operate tag

<p><b>⚠ WARNING</b></p> <p><b>Maintenance hazard!</b>  <b>Before you start servicing the machine, attach a DO NOT OPERATE warning tag to the machine in a visible area.</b>  <b>Failure to comply could result in death or serious injury.</b></p> <p style="text-align: right;">W0004A</p>
---

Attach a DO NOT OPERATE (TAG) to the machine in an area that is clearly visible whenever the machine is not operating properly and/or requires service. Complete the tag information for the "REASON" the tag is attached by describing the malfunction or service required. Validate the reason for attaching the tag by signing your name in the designated area on the tag. The tag should only be removed by the person who signed and attached the tag, after validating the repairs or services have been completed.



### Tag Components

- A. DO NOT REMOVE THIS TAG! - (Warning) The tag should only be removed by the person who signed and attached the tag, after validating the repairs or services have been completed.
- B. See Other Side - (Reference to additional information on opposite side of the tag.)
- C. CNH Part Number - (Request this part number from you Service Parts Dealer to obtain this DO NOT OPERATE tag.)
- D. DO NOT OPERATE - (Warning!)
- E. REASON - (Area for describing malfunction or service required before operation.)
- F. Signed by - (Signature area - to be signed by the person validating the reason for installation of the tag.)



---

## Safety rules

### General safety rules

Use caution when operating the machine on slopes. Raised equipment, full tanks and other loads will change the center of gravity of the machine. The machine can tip or roll over when near ditches and embankments or uneven surfaces.

Never permit anyone other than the operator to ride on the machine.

Never operate the machine under the influence of alcohol, drugs, or while otherwise impaired.

When digging or using ground engaging attachments be aware of buried cables. Contact local utilities to determine the locations of services.

Pay attention to overhead power lines and hanging obstacles. High voltage lines may require significant clearance for safety.

Hydraulic oil or diesel fuel leaking under pressure can penetrate the skin, causing serious injury or infection.

- DO NOT use your hand to check for leaks. Use a piece of cardboard or paper.
- Stop engine, remove key and relieve the pressure before connecting or disconnecting fluid lines.
- Make sure all components are in good condition and tighten all connections before starting the engine or pressurizing the system.
- If hydraulic fluid or diesel fuel penetrates the skin, seek medical attention immediately.
- Continuous long term contact with hydraulic fluid may cause skin cancer. Avoid long term contact and wash the skin promptly with soap and water.

Keep clear of moving parts. Loose clothing, jewelry, watches, long hair, and other loose or hanging items can become entangled in moving parts.

Wear protective equipment when appropriate.

DO NOT attempt to remove material from any part of the machine while it is being operated or components are in motion.

Make sure all guards and shields are in good condition and properly installed before operating the machine. Never operate the machine with shields removed. Always close access doors or panels before operating the machine.

Dirty or slippery steps, ladders, walkways, and platforms can cause falls. Make sure these surfaces remain clean and clear of debris.

A person or pet within the operating area of a machine can be struck or crushed by the machine or its equipment. DO NOT allow anyone to enter the work area.

Raised equipment and/or loads can fall unexpectedly and crush persons underneath. Never allow anyone to enter the area underneath raised equipment during operation.

Never operate engine in enclosed spaces as harmful exhaust gases may build up.

Before starting the machine, be sure that all controls are in neutral or park lock position.

Start the engine only from the operator's seat. If the safety start switch is bypassed, the engine can start with the transmission in gear. Do not connect or short across terminals on the starter solenoid. Attach jumper cables as described in the manual. Starting in gear may cause death or serious injury.

Always keep windows, mirrors, all lighting, and Slow Moving Vehicle (SMV) emblem clean to provide the best possible visibility while operating the machine.

Operate controls only when seated in the operator's seat, except for those controls expressly intended for use from other locations.

Before leaving the machine:

1. Park machine on a firm level surface.
2. Put all controls in neutral or park lock position.
3. Engage park brake. Use wheel chocks if required.
4. Lower all hydraulic equipment — Implements, header, etc.
5. Turn off engine and remove key.

When, due to exceptional circumstances, you would decide to keep the engine running after leaving the operator's station, then the following precautions must be followed:

1. Bring the engine to low idle speed.
2. Disengage all drive systems.

3. **⚠ WARNING**

**Some components may continue to run down after disengaging drive systems.  
Make sure all drive systems are fully disengaged.  
Failure to comply could result in death or serious injury.**

W0113A

Shift the transmission into neutral.

4. Apply the parking brake.

**⚠ General maintenance safety ⚠**

Keep area used for servicing the machine clean and dry. Clean up spilled fluids.

Service machine on a firm level surface.

Install guards and shields after servicing the machine.

Close all access doors and install all panels after servicing the machine.

Do not attempt to clean, lubricate, clear obstructions or make adjustments to the machine while it is in motion or while the engine is running.

Always make sure working area is clear of tools, parts, other persons and pets before you start operating the machine.

Unsupported hydraulic cylinders can lose pressure and drop the equipment causing a crushing hazard. Do not leave equipment in a raised position while parked or during service, unless securely supported.

Jack or lift the machine only at jack or lift points indicated in this manual.

Incorrect towing procedures can cause accidents. When towing a disabled machine follow the procedure in this manual. Use only rigid tow bars.

Stop the engine, remove key and relieve pressure before disconnecting or connecting fluid lines.

Stop the engine and remove key before disconnecting or connecting electrical connections.

Scalding can result from incorrect removal of coolant caps. Cooling system operates under pressure. Hot coolant can spray out if a cap is removed while the system is hot. Allow system to cool before removing cap. When removing a cap turn it slowly to allow pressure to escape before completely removing the cap.

Replace damaged or worn tubes, hoses, electrical wiring, etc.

Engine, transmission, exhaust components, and hydraulic lines may become hot during operation. Take care when servicing such components. Allow surfaces to cool before handling or disconnecting hot components. Wear protective equipment when appropriate.

When welding, follow the instructions in the manual. Always disconnect the battery before welding on the machine. Always wash your hands after handling battery components.

## **⚠ Wheels and tires ⚠**

Make sure tires are correctly inflated. Do not exceed recommended load or pressure. Follow instructions in the manual for proper tire inflation.

Tires are heavy. Handling tires without proper equipment could cause death or serious injury.

Never weld on a wheel with a tire installed. Always remove tire completely from wheel prior to welding.

Always have a qualified tire technician service the tires and wheels. If a tire has lost all pressure, take the tire and wheel to a tire shop or your dealer for service. Explosive separation of the tire can cause serious injury.

DO NOT weld to a wheel or rim until the tire is completely removed. Inflated tires can generate a gas mixture with the air that can be ignited by high temperatures from welding procedures performed on the wheel or rim. Removing the air or loosening the tire on the rim (breaking the bead) will NOT eliminate the hazard. This condition can exist whether tires are inflated or deflated. The tire MUST be completely removed from the wheel or rim prior to welding the wheel or rim.

## **⚠ Driving on public roads and general transportation safety ⚠**

Comply with local laws and regulations.

Use appropriate lighting to meet local regulations.

Make sure SMV emblem is visible.

Make sure brake pedal latch is engaged. Brake pedals must be locked together for road travel.

Use safety chains for trailed equipment when provided with machine or equipment.

Lift implements and attachments high enough above ground to prevent accidental contact with road.

When transporting equipment or machine on a transport trailer, make sure it is properly secured. Be sure the SMV on the equipment or machine is covered while being transported on a trailer.

Be aware of overhead structures or power lines and make sure the machine and/or attachments can pass safely under.

Travel speed should be such that complete control and machine stability is maintained at all times.

Slow down and signal before turning.

Pull over to allow faster traffic to pass.

Follow correct towing procedure for equipment with or without brakes.

Make sure the booms are locked in the cradles with the locking pins provided.

## **⚠ Fire and explosion prevention ⚠**

Fuel or oil leaked or spilled on hot surfaces or electrical components can cause a fire.

Crop materials, trash, debris, bird nests, or flammable material can ignite on hot surfaces.

Always have a fire extinguisher on or near the machine.

Make sure the fire extinguisher(s) is maintained and serviced according to the manufacturer's instructions.

At least once each day and at the end of the day remove all trash and debris from the machine especially around hot components such as engine, transmission, exhaust, battery, etc. More frequent cleaning of your machine may be necessary depending on the operating environment and conditions.

At least once each day, remove debris accumulation around moving components such as bearings, pulleys, belts, gears, cleaning fan, etc. More frequent cleaning of your machine may be necessary depending on the operating environment and conditions.

Inspect the electrical system for loose connections or frayed insulation. Repair or replace loose or damaged parts.

Do not store oily rags or other flammable material on the machine.

Do not weld or flame cut any items that contain flammable material. Clean items thoroughly with non-flammable solvents before welding or flame-cutting.

Do not expose the machine to flames, burning brush, or explosives.

Promptly investigate any unusual smells or odors that may occur during operation of the machine.

### **General battery safety**

Always wear eye protection when working with batteries.

Do not create sparks or have open flame near battery.

Ventilate when charging or using in an enclosed area.

Disconnect negative (-) first and reconnect negative (-) last.

When welding on the machine, disconnect both terminals of the battery.

Do not weld, grind, or smoke near a battery.

When using auxiliary batteries or connecting jumper cables to start the engine, use the procedure shown in the operator's manual. Do not short across terminals.

Follow manufacturer's instructions when storing and handling batteries.

Battery post, terminals, and related accessories contain lead and lead compounds. Wash hands after handling. This is a California Proposition 65 warning.

Battery acid causes burns. Batteries contain sulfuric acid. Avoid contact with skin, eyes, or clothing. Antidote (external): Flush with water. Antidote (eyes): flush with water for 15 minutes and seek medical attention immediately. Antidote (internal): Drink large quantities of water or milk. Do not induce vomiting. Seek medical attention immediately.

Keep out of reach of children and other unauthorized persons.

### **Instructional seat safety**

Passengers are not permitted to ride on the machine.

The instructional seat is to be used only when training a new operator or when a service technician is diagnosing a problem.

When required for the purposes of training or diagnostics, only one person may accompany the operator and that person must be seated in the instructional seat.

When the instructional seat is occupied, the following precautions must be followed:

- Machine should be driven only at slow speeds and over level ground.
- Avoid driving on highways or public roads.
- Avoid quick starts or stops.
- Avoid sharp turns.
- Always wear correctly adjusted seat belts.
- Keep door closed at all times.

### **Operator presence system**

Your machine is equipped with an operator presence system to prevent the use of some features while the operator is not in the operator's seat.

The operator presence system should never be disconnected or bypassed.

If the system is inoperable, the system must be repaired.

### **Reflectors and warning lights**

Flashing amber warning lights must be used when operating on public roads. Refer to Chapter 5 — Transport Operations for complete identification and operating instructions.

### **Seat belts**

Seat belts must be worn at all times.

Seat belt inspection and maintenance:

- Keep seat belts in good condition.
- Keep sharp edges and items that can cause damage away from the belts.
- Periodically check belts, buckles, retractors, tethers, slack take-up system, and mounting bolts for damage and wear.
- Replace all parts that have damage or wear.
- Replace belts that have cuts that can make the belt weak.
- Check that bolts are tight on the seat bracket or mounting.
- If belt is attached to seat, make sure seat or seat brackets are mounted securely.
- Keep seat belts clean and dry.
- Clean belts only with soap solution and warm water.
- Do not use bleach or dye on the belts because this can make the belts weak.
- Refer to Chapter 4 — Operating Instructions for proper use and adjustment of seat belts.

### **Air-conditioning system**

The air-conditioning system is under high pressure. Do not disconnect any lines. The release of high pressure can cause serious injury.

The air-conditioning system contains gases that are harmful to the environment when released into the atmosphere. Do not attempt to service or repair the system.

Service, repair, or recharging must be performed only by a trained service technician.

### **Personal Protective Equipment (PPE)**

Wear Personal Protective Equipment (PPE) such as hard hat, eye protection, heavy gloves, hearing protection, protective clothing, etc.

### **Do Not Operate tag**

Before you start servicing the machine, attach a 'Do Not Operate' warning tag to the machine in an area that will be visible.

### **Hazardous chemicals**

If you are exposed to or come in contact with hazardous chemicals you can be seriously injured. The fluids, lubricants, paints, adhesives, coolant, etc. required for the function of your machine can be hazardous. They may be attractive and harmful to domestic animals as well as humans.

Material Safety Data Sheets (MSDS) provide information about the chemical substances within a product, safe handling and storage procedures, first aid measures and procedures to be taken in the event of a spill or accidental release. MSDS are available from your dealer.

Before you service your machine check the MSDS for each lubricant, fluid, etc. used in this machine. This information indicates the associated risks and will help you service the machine safely. Follow the information in the MSDS, on manufacturer containers, as well as the information in this manual when servicing the machine.

Dispose of all fluids, filters, and containers in an environmentally safe manner according to local laws and regulations. Check with local environmental and recycling centers or your dealer for correct disposal information.

Store fluids and filters in accordance with local laws and regulations. Use only appropriate containers for the storage of chemicals or petrochemical substances.

Keep out of reach of children or other unauthorized persons.

Additional precautions are required for applied chemicals. Obtain complete information from the manufacturer or distributor of the chemicals before using them.

### **Utility safety**

When digging or using ground-engaging equipment, be aware of buried cables and other services. Contact your local utilities or authorities, as appropriate to determine the locations of services.

Make sure the machine has sufficient clearance to pass in all directions. Pay special attention to overhead power lines and hanging obstacles. High voltage lines may require significant clearance for safety. Contact local authorities or utilities to obtain safe clearance distances from high voltage power lines.

Retract raised or extended components, if necessary. Remove or lower radio antennas or other accessories. Should a contact between the machine and an electric power source occur, the following precautions must be taken:

- Stop the machine movement immediately.
- Apply the park brake, stop the engine, and remove the key.
- Check if you can safely leave the cab or your actual position without contact with electrical wires. If not, stay in your position and call for help. If you can leave your position without touching lines, jump clear of the machine to make sure you do not make contact with the ground and the machine at the same time.

- Do not permit anyone to touch the machine until power has been shut off to the power lines.

### **⚠ Electrical storm safety ⚠**

Do not operate machine during an electrical storm.

If you are on the ground during an electrical storm, stay away from machinery and equipment. Seek shelter in a permanent, protected structure.

If an electrical storm should strike during operation, remain in the cab. Do not leave the cab or operator's platform. Do not make contact with the ground or objects outside the machine.

### **⚠ Mounting and dismounting ⚠**

Mount and dismount the machine only at designated locations that have handholds, steps, or ladders.

Do not jump off the machine.

Make sure steps, ladders, and platforms remain clean and clear of debris and foreign substances. Injury may result from slippery surfaces.

Face the machine when mounting and dismounting.

Maintain a three-point contact with steps, ladders, and handholds.

Never mount or dismount from a moving machine.

Do not use the steering wheel or other controls or accessories as handholds when entering or exiting the cab or operator's platform.

### **⚠ Working at heights ⚠**

When the normal use and maintenance of the machine requires working at heights:

- Correctly use installed steps, ladders, and railings.
- Never use ladders, steps, or railings while the machine is moving.
- Do not stand on surfaces which are not designated as steps or platforms.

Do not use the machine as a lift, ladder, or platform for working at heights.

### **⚠ Spraying ⚠**

- Be sure to clean and flush all residual chemicals from the sprayer before changing to another type of chemical. On some models, it may be necessary to remove the end caps from the spray bars to thoroughly flush the boom plumbing. In some cases a decontamination solution is recommended by the chemical manufacturer.
- Always follow chemical manufacturers safety instructions when mixing and applying herbicides and chemicals to prevent serious harm to people or the environment.
- Observe all Federal and State EPA regulations and all Local, State and Federal codes and/or laws regarding licensing, handling, storage, transportation, application and waste disposal of herbicides or other chemicals.

**⚠ Roll over and tip over ⚠**

- Travel speed should be such that complete control and machine stability is maintained at all times. Where possible, avoid operating near ditches, embankments and holes. Reduce speed when turning, crossing slopes, and on rough, slick, or muddy surfaces.
- Do not operate the unit on terrain outside its grade and stability limits. Operating the sprayer outside its limits may result in a roll over or tip over.
- Operating the unit on steep grades may result in a machine overturn. It is the operator's responsibility to make a judgment if weather, road or ground conditions permit safe operation on a hillside, ramp, ditch or rough ground.
- Use caution when operating the machine on slopes. Raised equipment, full tanks and other loads can change the center of gravity of the machine. The machine can tip or roll over when near ditches and embankments or uneven surfaces.
- Do not operate the unit near or on the soft shoulders of canals, brooks, other waterways or banks which are undermined by rodents. The unit may sink sideways and roll over.
- Do not operate the unit on poorly constructed or underrated ramps. The ramps may collapse and cause the sprayer to roll over. Always check the condition and rating of ramps before use.
- Do not operate the unit without using the seat restraint.
- Do not operate the unit beyond its limits of dynamic stability. High speed, abrupt maneuvers or fast and sharp cornering increase the risk of roll over.



---

## Basic instructions - Ecology and the environment

Soil, air, and water are vital factors of agriculture and life in general. When legislation does not yet rule the treatment of some of the substances required by advanced technology, sound judgment should govern the use and disposal of products of a chemical and petrochemical nature.

**NOTE:** *The following are recommendations that may be of assistance:*

- Become acquainted with and ensure that you understand the relative legislation applicable to your country.
- Where no legislation exists, obtain information from suppliers of oils, filters, batteries, fuels, antifreeze, cleaning agents, etc., with regard to their effect on man and nature and how to safely store, use, and dispose of these substances.
- Agricultural consultants will, in many cases, be able to help you as well.

### Helpful hints

- Avoid filling tanks using cans or inappropriate pressurized fuel delivery systems that may cause considerable spillage.
- In general, avoid skin contact with all fuels, oils, acids, solvents, etc. Most of them contain substances that may be harmful to your health.
- Modern oils contain additives. Do not burn contaminated fuels and or waste oils in ordinary heating systems.
- Avoid spillage when draining off used engine coolant mixtures, engine, gearbox and hydraulic oils, brake fluids, etc. Do not mix drained brake fluids or fuels with lubricants. Store them safely until they can be disposed of in a proper way to comply with local legislation and available resources.
- Modern coolant mixtures, i.e. antifreeze and other additives, should be replaced according to the maintenance section. They should not be allowed to get into the soil, but should be collected and disposed of properly.
- Do not open the air-conditioning system yourself. It contains gases that should not be released into the atmosphere. Your CASE IH dealer or air conditioning specialist has a special extractor for this purpose and will have to recharge the system properly.
- Repair any leaks or defects in the engine cooling or hydraulic system immediately.
- Do not increase the pressure in a pressurized circuit as this may lead to a component failure.
- Protect hoses during welding as penetrating weld splatter may burn a hole or weaken them, allowing the loss of oils, coolant, etc.

---

## **Basic instructions - Important notice regarding equipment servicing**

All repair and maintenance work listed in this manual must be carried out only by qualified dealership personnel, strictly complying with the instructions given, and using, whenever possible, the special tools.

Anyone who performs repair and maintenance operations without complying with the procedures provided herein shall be responsible for any subsequent damages.

The manufacturer and all the organizations of its distribution chain, including - without limitation - national, regional, or local dealers, reject any responsibility for damages caused by parts and/or components not approved by the manufacturer, including those used for the servicing or repair of the product manufactured or marketed by the manufacturer. In any case, no warranty is given or attributed on the product manufactured or marketed by the manufacturer in case of damages caused by parts and/or components not approved by the manufacturer.

The information in this manual is up-to-date at the date of the publication. It is the policy of the manufacturer for continuous improvement. Some information could not be updated due to modifications of a technical or commercial type, or changes to the laws and regulations of different countries.

In case of questions, refer to your CASE IH Sales and Service Networks.

---

## Basic instructions - Shop and assembly

### Shimming

For each adjustment operation, select adjusting shims and measure individually using a micrometer, then add up the recorded values. Do not rely on measuring the entire shimming set, which may be incorrect, or the rated value indicated on each shim.

### Rotating shaft seals

For correct rotating shaft seal installation, proceed as follows:

- Before assembly, allow the seal to soak in the oil it will be sealing for at least thirty minutes.
- Thoroughly clean the shaft and check that the working surface on the shaft is not damaged.
- Position the sealing lip facing the fluid; with hydrodynamic lips, take into consideration the shaft rotation direction and position the grooves so that they will deviate the fluid towards the inner side of the seal.
- Coat the sealing lip with a thin layer of lubricant (use oil rather than grease) and fill the gap between the sealing lip and the dust lip on double lip seals with grease unless instructed otherwise.
- Insert the seal in its seat and press down using a flat punch or seal installation tool. Do not tap the seal with a hammer or mallet.
- While inserting the seal, check that it is perpendicular to the seat; once settled, make sure that it makes contact with the thrust element, if required.
- To prevent damaging the seal lip on the shaft, position a protective guard during installation operations.

### O-ring seals

Lubricate the O-ring seals before inserting them in the seats, this will prevent them from overturning and twisting, which would jeopardize sealing efficiency.

### Sealing compounds

Apply one of the following sealing compounds on the mating surfaces when specified: SILMATE® RTV1473, or **LOCTITE® RTV 598** or **LOCTITE® INSTANT GASKET 587 BLUE**. Before applying the sealing compound, prepare the surfaces as directed on product container or as follows:

- Remove any incrustations using a metal brush.
- Thoroughly de-grease the surfaces using a locally approved cleaning agent such as safety solvent or brake parts cleaner.

### Spare parts

Only use "CNH Original Parts" or "CASE IH Parts".

Only genuine spare parts guarantee the same quality, duration and safety as original parts, as they are the same parts that are assembled during standard production. Only "CNH Original Parts" or "CASE IH Parts" can offer this guarantee.

When ordering spare parts, always provide the following information:

- Machine model (commercial name) and serial number
- Part number of the ordered part, which can be found in the "Service Parts Catalogue", used for order processing

---

## Protecting the electrical/electronic systems during charging or welding

### **⚠ WARNING**

**Battery acid causes burns. Batteries contain sulfuric acid.**

**Avoid contact with skin, eyes or clothing. Antidote (external): Flush with water. Antidote (eyes): flush with water for 15 minutes and seek medical attention immediately. Antidote (internal): Drink large quantities of water or milk. Do not induce vomiting. Seek medical attention immediately.**

**Failure to comply could result in death or serious injury.**

W0111A

To avoid damage to the electronic/electrical systems, always observe the following:

1. Never make or break any of the charging circuit connections, including the battery connections, when the engine is running.
2. Never short any of the charging components to ground.
3. Always disconnect the ground cable from the battery before arc welding on the machine or on any attachments on the machine.
  - Position the welder ground clamp as close to the welding area as possible
  - If welding in close proximity to a computer module, then the module should be removed from the machine
  - Never allow welding cables to lay on, near or across any electrical wiring or electronic component while welding is in progress
4. Always disconnect the negative cable from the battery when charging the battery in the machine with a battery charger.

**NOTICE:** *If welding must be performed on the unit, the battery ground cable must be disconnected from the machine battery. The electronic monitoring system and charging system will be damaged if this is not done.*

Remove the battery ground cable. Reconnect the cable when welding is completed.

### **Tools**

The tools that CASE IH suggests and illustrated in this manual have been:

- Specifically researched and designed for use with CASE IH machines
- Essential for reliable repair operations
- Accurately built and rigorously tested so as to offer efficient and long-lasting operation

By using these tools, repair personnel will benefit from:

- Operating in optimal technical conditions
- Obtaining the best results
- Saving time and effort
- Working in safe conditions

**NOTE:** *The terms "front", "rear", "right-hand" and "left-hand" (when referred to different parts) are determined from the rear, facing in the direction of travel of the machine during operation.*

## Basic instructions

### Product Identification Number (PIN) plate

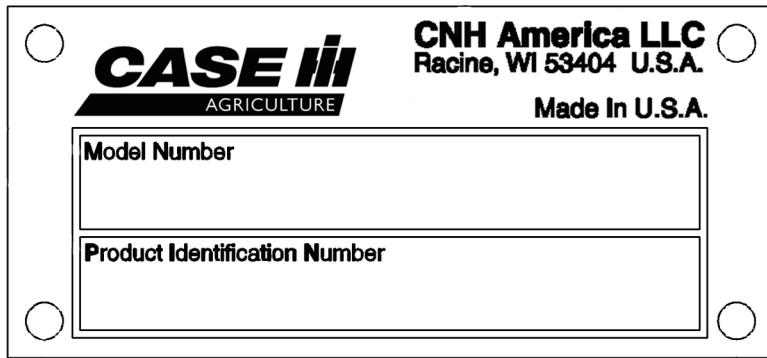

RCPH10FWD961EAM 1

Model :

PIN:

**NOTE:** Located on the front of the catwalk by the ladder on the left side of the machine.

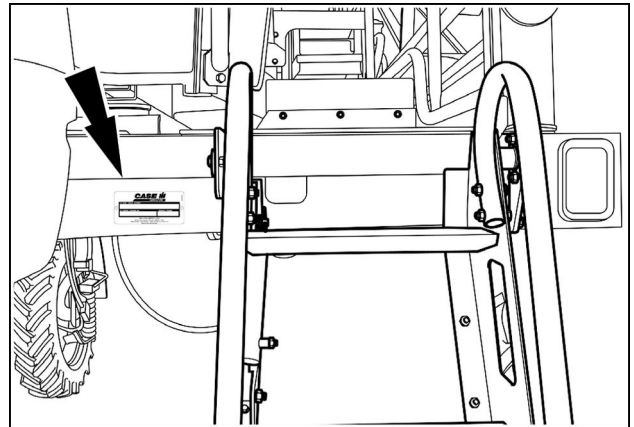

### Engine serial number

Serial number:

**NOTE:** Located on valve cover toward front side of the engine.

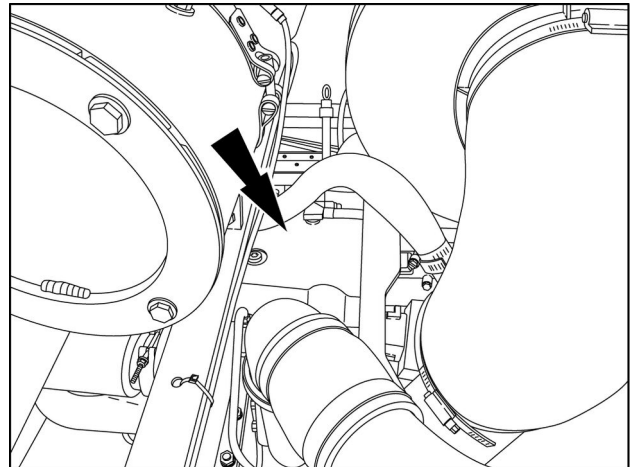

## Torque - Minimum tightening torques for normal assembly

### Decimal hardware

#### Grade 5 bolts, nuts and studs

Size	Nm	lb in/lb ft
1/4 in	12 - 15 Nm	108 - 132 lb in
5/16 in	23 - 28 Nm	204 - 252 lb in
3/8 in	48 - 57 Nm	420 - 504 lb in
7/16 in	73 - 87 Nm	54 - 64 lb ft
1/2 in	109 - 130 Nm	80 - 96 lb ft
9/16 in	149 - 179 Nm	110 - 132 lb ft
5/8 in	203 - 244 Nm	150 - 180 lb ft
3/4 in	366 - 439 Nm	270 - 324 lb ft
7/8 in	542 - 651 Nm	400 - 480 lb ft
1 in	787 - 944 Nm	580 - 696 lb ft
1-1/8 in	1085 - 1193 Nm	800 - 880 lb ft
1-1/4 in	1519 - 1681 Nm	1120 - 1240 lb ft
1-3/8 in	1980 - 2278 Nm	1460 - 1680 lb ft
1-1/2 in	2631 - 2983 Nm	1940 - 2200 lb ft

#### Grade 8 bolts, nuts and studs

Size	Nm	lb in/lb ft
1/4 in	16 - 20 Nm	144 - 180 lb in
5/16 in	33 - 39 Nm	288 - 348 lb in
3/8 in	61 - 73 Nm	540 - 648 lb in
7/16 in	95 - 114 Nm	70 - 84 lb ft
1/2 in	149 - 179 Nm	110 - 132 lb ft
9/16 in	217 - 260 Nm	160 - 192 lb ft
5/8 in	298 - 358 Nm	220 - 264 lb ft
3/4 in	515 - 618 Nm	380 - 456 lb ft
7/8 in	814 - 976 Nm	600 - 720 lb ft
1 in	1220 - 1465 Nm	900 - 1080 lb ft
1-1/8 in	1736 - 1953 Nm	1280 - 1440 lb ft
1-1/4 in	2468 - 2712 Nm	1820 - 2000 lb ft
1-3/8 in	3227 - 3688 Nm	2380 - 2720 lb ft
1-1/2 in	4285 - 4827 Nm	3160 - 3560 lb ft

**NOTE:** Use thick nuts with Grade 8 bolts.

### Metric hardware

#### Grade 8.8 bolts, nuts and studs

Size	Nm	lb in/lb ft
4 mm	3 - 4 Nm	24 - 36 lb in
5 mm	7 - 8 Nm	60 - 72 lb in
6 mm	11 - 12 Nm	96 - 108 lb in
8 mm	26 - 31 Nm	228 - 276 lb in
10 mm	52 - 61 Nm	456 - 540 lb in
12 mm	90 - 107 Nm	66 - 79 lb ft
14 mm	144 - 172 Nm	106 - 127 lb ft
16 mm	217 - 271 Nm	160 - 200 lb ft
20 mm	434 - 515 Nm	320 - 380 lb ft
24 mm	675 - 815 Nm	500 - 600 lb ft
30 mm	1250 - 1500 Nm	920 - 1100 lb ft
36 mm	2175 - 2600 Nm	1600 - 1950 lb ft

**Grade 10.9 bolts, nuts and studs**

Size	Nm	lb in/lb ft
4 mm	4 - 5 Nm	36 - 48 lb in
5 mm	9 - 11 Nm	84 - 96 lb in
6 mm	15 - 18 Nm	132 - 156 lb in
8 mm	37 - 43 Nm	324 - 384 lb in
10 mm	73 - 87 Nm	54 - 64 lb ft
12 mm	125 - 150 Nm	93 - 112 lb ft
14 mm	200 - 245 Nm	149 - 179 lb ft
16 mm	310 - 380 Nm	230 - 280 lb ft
20 mm	610 - 730 Nm	450 - 540 lb ft
24 mm	1050 - 1275 Nm	780 - 940 lb ft
30 mm	2000 - 2400 Nm	1470 - 1770 lb ft
36 mm	3500 - 4200 Nm	2580 - 3090 lb ft

**Grade 12.9 bolts, nuts and studs**

Size	Nm	lb in/lb ft
Typically the torque values specified for grade 10.9 hardware can be used satisfactorily on grade 12.9 hardware.		

**Steel hydraulic fittings**

**37° flare fitting**

Tube outside diameter/Hose inside diameter		Thread size	Nm	lb in/lb ft
mm	inch			
6.4 mm	1/4 in	7/16-20 in	8 - 16 Nm	72 - 144 lb in
7.9 mm	5/16 in	1/2-20 in	11 - 22 Nm	96 - 192 lb in
9.5 mm	3/8 in	9/16-18 in	14 - 34 Nm	120 - 300 lb in
12.7 mm	1/2 in	3/4-16 in	20 - 57 Nm	180 - 504 lb in
15.9 mm	5/6 in	7/8-14 in	34 - 79 Nm	300 - 696 lb in
19.0 mm	3/4 in	1-1/16-12 in	54 - 108 Nm	40 - 80 lb ft
22.2 mm	7/8 in	1-3/16-12 in	81 - 135 Nm	60 - 100 lb ft
25.4 mm	1 in	1-5/16-12 in	102 - 158 Nm	75 - 117 lb ft
31.8 mm	1-1/4 in	1-5/8-12 in	169 - 223 Nm	125 - 165 lb ft
38.1 mm	1-1/2 in	1-7/8-12 in	285 - 338 Nm	210 - 250 lb ft

**Straight threads with O-ring**

Tube outside diameter/Hose inside diameter		Thread size	Nm	lb in/lb ft
mm	inch			
6.4 mm	1/4 in	7/16-20 in	16 - 26 Nm	144 - 228 lb in
7.9 mm	5/16 in	1/2-20 in	22 - 34 Nm	192 - 300 lb in
9.5 mm	3/8 in	9/16-18 in	34 - 54 Nm	300 - 480 lb in
12.7 mm	1/2 in	3/4-16 in	57 - 91 Nm	540 - 804 lb in
15.9 mm	5/6 in	7/8-14 in	79 - 124 Nm	58 - 92 lb ft
19.0 mm	3/4 in	1-1/16-12 in	108 - 174 Nm	80 - 128 lb ft
22.2 mm	7/8 in	1-3/16-12 in	136 - 216 Nm	100 - 160 lb ft
25.4 mm	1 in	1-5/16-12 in	159 - 253 Nm	117 - 187 lb ft
31.8 mm	1-1/4 in	1-5/8-12 in	224 - 357 Nm	165 - 264 lb ft
38.1 mm	1-1/2 in	1-7/8-12 in	339 - 542 Nm	250 - 400 lb ft

**Split flange mounting bolts**

Size	Nm	lb in/lb ft
5/16-18 in	20 - 27 Nm	180 - 240 lb in
3/8-16 in	27 - 34 Nm	240 - 300 lb in
7/16-14 in	47 - 61 Nm	420 - 540 lb in
1/2-13 in	74 - 88 Nm	55 - 65 lb ft

INTRODUCTION

Size	Nm	lb in/lb ft
5/8-11 in	190 - 203 Nm	140 - 150 lb ft

Nominal SAE dash size	O-ring face seal end		Thread size	Nm	lb in/lb ft	O-ring boss end fitting or lock nut		
	Tube outside diameter mm	in				Thread size	Nm	lb in/lb ft
-4	6.4 mm	1/4 in	9/16-18 in	14 - 16 Nm	120 - 144 lb in	7/16-20 in	23 - 27 Nm	204 - 240 lb in
-6	9.5 mm	3/8 in	11/16-16 in	24 - 27 Nm	216 - 240 lb in	9/16-18 in	34 - 41 Nm	300 - 360 lb in
-8	12.7 mm	1/2 in	13/16-16 in	43 - 54 Nm	384 - 480 lb in	3/4-16 in	61 - 68 Nm	540 - 600 lb in
-10	15.9 mm	5/8 in	1-14 in	62 - 76 Nm	552 - 672 lb in	7/8-14 in	81 - 88 Nm	60 - 65 lb ft
-12	19.0 mm	3/4 in	1-3/16-12 in	90 - 110 Nm	65 - 80 lb ft	1-1/16-12 in	115 - 122 Nm	85 - 90 lb ft
-14	22.2 mm	7/8 in	1-3/16-12 in	90 - 110 Nm	65 - 80 lb ft	1-13/16-12 in	129 - 136 Nm	95 - 100 lb ft
-16	25.41 mm	1.0 in	1-7/16-12 in	125 - 140 Nm	92 - 105 lb ft	1-5/16-12 in	156 - 169 Nm	115 - 125 lb ft
-20	31.8 mm	1-1/4 in	1-11/16-12 in	170 - 190 Nm	125 - 140 lb ft	1-5/6-12 in	201 - 217 Nm	150 - 160 lb ft
-24	38.1 mm	1-1/2 in	2-12 in	200 - 254 Nm	150 - 180 lb ft	1-7/8-12 in	258 - 271 Nm	190 - 200 lb ft



## Torque - Standard torque data for hydraulics

### Installation of adjustable fittings in straight thread O-ring bosses

1. Lubricate the O-ring by coating it with a light oil or petroleum. Install the O-ring in the groove adjacent to the metal backup washer which is assembled at the extreme end of the groove (4).
2. Install the fitting into the SAE straight thread boss until the metal backup washer contacts the face of the boss (5).

**NOTE:** Do not over tighten and distort the metal backup washer.

3. Position the fitting by turning out (counterclockwise) up to a maximum of one turn. Holding the pad of the fitting with a wrench, tighten the locknut and washer against the face of the boss (6).

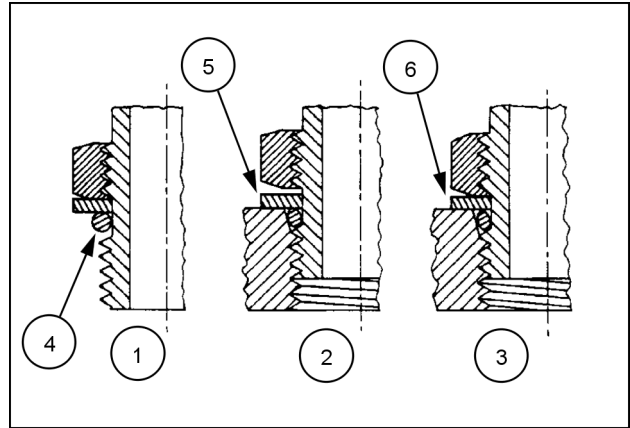

23085659 1

### Standard torque data for hydraulic tubes and fittings

Tube nuts for 37° flared fittings				O-ring boss plugs adjustable fitting locknuts, swivel JIC-37° seats
Size	Tubing OD	Thread size	Torque	Torque
4	6.4 mm (1/4 in)	7/16-20	12 - 16 N·m (9 - 12 lb ft)	8 - 14 N·m (6 - 10 lb ft)
5	7.9 mm (5/16 in)	1/2-20	16 - 20 N·m (12 - 15 lb ft)	14 - 20 N·m (10 - 15 lb ft)
6	9.5 mm (3/8 in)	9/16-18	29 - 33 N·m (21 - 24 lb ft)	20 - 27 N·m (15 - 20 lb ft)
8	12.7 mm (1/2 in)	3/4-16	47 - 54 N·m (35 - 40 lb ft)	34 - 41 N·m (25 - 30 lb ft)
10	15.9 mm (5/8 in)	7/8-14	72 - 79 N·m (53 - 58 lb ft)	47 - 54 N·m (35 - 40 lb ft)
12	19.1 mm (3/4 in)	1-1/16-12	104 - 111 N·m (77 - 82 lb ft)	81 - 95 N·m (60 - 70 lb ft)
14	22.2 mm (7/8 in)	1-3/16-12	122 - 136 N·m (90 - 100 lb ft)	95 - 109 N·m (70 - 80 lb ft)
16	25.4 mm (1 in)	1-5/16-12	149 - 163 N·m (110 - 120 lb ft)	108 - 122 N·m (80 - 90 lb ft)
20	31.8 mm (1-1/4 in)	1-5/8-12	190 - 204 N·m (140 - 150 lb ft)	129 - 158 N·m (95 - 115 lb ft)
24	38.1 mm (1-1/2 in)	1-7/8-12	217 - 237 N·m (160 - 175 lb ft)	163 - 190 N·m (120 - 140 lb ft)
32	50.8 mm (2 in)	2-1/2-12	305 - 325 N·m (225 - 240 lb ft)	339 - 407 N·m (250 - 300 lb ft)

These torques are not recommended for tubes of 12.7 mm (1/2 in) OD and larger with wall thickness of 0.889 mm (0.035 in) or less. The torque is specified for 0.889 mm (0.035 in) wall tubes on each application individually.

Before installing and torquing 37° flared fittings, clean the face of the flare and threads with a clean solvent or Loctite cleaner and apply hydraulic sealant **LOCTITE® 569** to the 37° flare and the threads.

Install fitting and torque to specified torque, loosen fitting and retorquing to specifications.

**Pipe thread fitting torque**

Before installing and tightening pipe fittings, clean the threads with a clean solvent or Loctite cleaner and apply sealant **LOCTITE® 567 PST PIPE SEALANT** for all fittings including stainless steel or **LOCTITE® 565 PST** for most metal fittings. For high filtration/zero contamination systems use **LOCTITE® 545**.

Thread size	Torque (maximum)
1/8-27	<b>13 N·m (10 lb ft)</b>
1/4-18	<b>16 N·m (12 lb ft)</b>
3/8-18	<b>22 N·m (16 lb ft)</b>
1/2-14	<b>41 N·m (30 lb ft)</b>
3/4-14	<b>54 N·m (40 lb ft)</b>

**Installation of ORFS (O-Ring Flat Seal fittings)**

When installing ORFS fittings thoroughly clean both flat surfaces of the fittings **(1)** and lubricate the O-ring **(2)** with light oil. Make sure both surfaces are aligned properly. Torque the fitting to specified torque listed throughout the repair manual.

**NOTICE:** If the fitting surfaces are not properly cleaned, the O-ring will not seal properly. If the fitting surfaces are not properly aligned, the fittings may be damaged and will not seal properly.

**NOTICE:** Always use genuine factory replacement oils and filters to ensure proper lubrication and filtration of engine and hydraulic system oils.

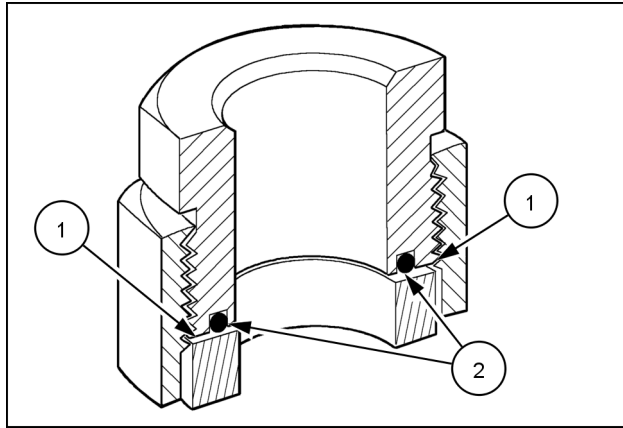

50011183 2

The use of proper oils, grease, and keeping the hydraulic system clean will extend machine and component life.

Thank you so much for reading.  
Please click the “Buy Now!”  
button below to download the  
complete manual.



After you pay.

You can download the most  
perfect and complete manual in  
the world immediately.

Our support email:

[ebooklibonline@outlook.com](mailto:ebooklibonline@outlook.com)