

**S3L2**  
Engine

**SERVICE MANUAL**

**Part number 47581892**  
1<sup>st</sup> edition English  
July 2013



# Contents

---

## INTRODUCTION

Engine.....	10
[10.001] Engine and crankcase .....	10.1
[10.101] Cylinder heads .....	10.2
[10.102] Pan and covers .....	10.3
[10.103] Crankshaft and flywheel.....	10.4
[10.105] Connecting rods and pistons.....	10.5
[10.106] Valve drive and gears .....	10.6
[10.114] Pump drives .....	10.7
[10.206] Fuel filters .....	10.8
[10.218] Fuel injection system.....	10.9
[10.220] Throttle linkage.....	10.10
[10.254] Intake and exhaust manifolds and muffler .....	10.11
[10.304] Engine lubrication system.....	10.12
[10.400] Engine cooling system .....	10.13
[10.414] Fan and drive .....	10.14
Electrical systems.....	55
[55.010] Fuel injection system.....	55.1
[55.013] Engine oil system .....	55.2
[55.201] Engine starting system.....	55.3
[55.202] Cold start aid .....	55.4
[55.301] Alternator.....	55.5



# INTRODUCTION

# Contents

---

## INTRODUCTION

Foreword .....	3
Foreword - Ecology and the environment .....	4
Safety rules .....	5
Safety rules .....	7
Basic instructions - Important notice regarding equipment servicing .....	8
Torque - Minimum tightening torques for normal assembly .....	9
Basic instructions - Shop and assembly .....	14
General specification - Biodiesel Fuels .....	16
General specification - General Welding .....	17
Product identification .....	18

## **Foreword**

This service manual describes the specifications, maintenance and service procedures for Mitsubishi diesel engines.

To maintain the performance of the engine for many years and to ensure safe operation, it is important to use the engine correctly and conduct regular inspection and maintenance, and also to take necessary measures which involves the disassembly, inspection, repair and reassembly of the engine and engine parts.

Read this manual carefully and understand the work procedures fully before disassembling, inspecting, repairing or reassembling the engine.

The contents of the manual are based on the engine models that are being produced at the time of publication. Due to improvements made thereafter, the actual engine that you work on may differ partially from the one described in this manual.

## Foreword - Ecology and the environment

Soil, air, and water are vital factors of agriculture and life in general. When legislation does not yet rule the treatment of some of the substances required by advanced technology, sound judgment should govern the use and disposal of products of a chemical and petrochemical nature.

**NOTE:** *The following are recommendations that may be of assistance:*

- Become acquainted with and ensure that you understand the relative legislation applicable to your country.
- Where no legislation exists, obtain information from suppliers of oils, filters, batteries, fuels, antifreeze, cleaning agents, etc., with regard to their effect on man and nature and how to safely store, use, and dispose of these substances.
- Agricultural consultants will, in many cases, be able to help you as well.

### Helpful hints

- Avoid filling tanks using cans or inappropriate pressurized fuel delivery systems that may cause considerable spillage.
- In general, avoid skin contact with all fuels, oils, acids, solvents, etc. Most of them contain substances that may be harmful to your health.
- Modern oils contain additives. Do not burn contaminated fuels and or waste oils in ordinary heating systems.
- Avoid spillage when draining off used engine coolant mixtures, engine, gearbox and hydraulic oils, brake fluids, etc. Do not mix drained brake fluids or fuels with lubricants. Store them safely until they can be disposed of in a proper way to comply with local legislation and available resources.
- Modern coolant mixtures, i.e. antifreeze and other additives, should be replaced every two years. They should not be allowed to get into the soil, but should be collected and disposed of properly.
- Do not open the air-conditioning system yourself. It contains gases that should not be released into the atmosphere. Your CNH dealer or air conditioning specialist has a special extractor for this purpose and will have to recharge the system properly.
- Repair any leaks or defects in the engine cooling or hydraulic system immediately.
- Do not increase the pressure in a pressurized circuit as this may lead to a component failure.
- Protect hoses during welding as penetrating weld splatter may burn a hole or weaken them, allowing the loss of oils, coolant, etc.

---

## Safety rules

### Standard safety precautions

Be informed and notify personnel of the laws in force regulating safety, and provide documentation available for consultation.

- Keep working areas as clean as possible.
- Ensure that working areas are provided with emergency boxes. They must be clearly visible and always contain adequate sanitary equipment.
- Fire extinguishers must be properly identified and always be clear of obstructions. Their efficiency must be checked on a regular basis and personnel must be trained on proper interventions and priorities.
- Keep all emergency exits free of obstructions and clearly marked.
- Smoking in working areas subject to fire danger must be strictly prohibited.

### Prevention of injury

- Wear suitable work attire and safety glasses with no jewelry such as rings and chains when working close to engines and equipment in motion.
- Wear safety gloves and goggles when performing the following operations:
  - Topping off or changing lubrication oils.
  - Using compressed air or liquids at a pressure greater than **2 bar (29 psi)**.
- Wear a safety helmet when working close to hanging loads or equipment working at head level.
- Always wear safety shoes and fitting clothes.
- Use protection cream for hands.
- Change wet clothes as soon as possible.
- In the presence of voltages exceeding **48 - 60 V**, verify the efficiency of the ground and mass electrical connections. Ensure that hands and feet are dry and use isolating foot boards. Workers should be properly trained to work with electricity.
- Do not smoke or start an open flame close to batteries and any fuel material.
- Place soiled rags with oil, diesel fuel or solvents in specially provided anti-fire containers.
- Do not use any tool or equipment for any use other than what it was originally intended for. Serious injury may occur.
- If running an engine indoors, make sure there is a sufficient exhaust fan in use to eliminate exhaust fumes.

### During maintenance

- Never open the filler cap of the cooling system when the engine is hot. High temperature liquid at operating pressure could result in serious danger and risk of burn. Wait until the temperature decreases under **50 °C (122 °F)**.
- Never add coolant to an overheated engine and use only appropriate liquids.
- Always work when the engine is turned off. Certain circumstances require maintenance on a running engine. Be aware of all the risks involved with such an operation.
- Always use adequate and safe containers for engine fluids and used oil.
- Keep engine clean of any spilled fluids such as oil, diesel fuel, and or chemical solvents.
- Use of solvents or detergents during maintenance may emit toxic vapors. Always keep working areas aerated. Wear a safety mask if necessary.
- Do not leave soiled rags that may contain any flammable substances close to the engine.
- Always use caution when starting an engine after any work has been performed. Be prepared to cut off intake air in case of engine runaway.
- Never disconnect the batteries while the engine is running.
- Disconnect the batteries prior to performing any work on the equipment.

- Disconnect the batteries to place a load on them with a load tester.
- After any work is performed, verify that the battery clamp polarity is correct and that the clamps are tight and safe from accidental short circuit and oxidation.
- Before disconnecting any pipelines (pneumatic, hydraulic, fuel pipes, etc.), verify that all pressure has been released. Take all necessary precautions bleeding and draining residual pressure. Always wear the proper safety equipment.
- Do not alter the lengths of any wires.
- Do not connect any electronic service tool to the engine electrical equipment unless specifically approved by CNH.
- Do not modify the fuel system or hydraulic system unless approved by CNH. Any unauthorized modification will compromise warranty assistance and may affect engine operation and life span.

For engine equipped with an electronic control unit

- Do not weld on any part of the equipment without removing the control unit.
- Remove the in case of work requiring heating over **80 °C (176 °F)**.
- Do not paint the components and the electronic connections.
- Do not alter any data filed in the electronic control unit driving the engine. Any manipulation or alteration of electronic components will void engine warranty assistance and may affect the correct working order and life span of the engine.

### **Respect of the Environment**

- Respect of the environment should be of primary importance. Take all necessary precautions to ensure personnel's safety and health.
- Inform the personnel of the laws regarding the dispensing of used engine fluids.
- Handle batteries with care, storing them in a well ventilated environment and within anti-acid container.



## Safety rules

### Personal safety



This is the safety alert symbol. It is used to alert you to potential personal injury hazards. Obey all safety messages that follow this symbol to avoid possible death or injury.

Throughout this manual and on machine decals, you will find the signal words DANGER, WARNING, and CAUTION followed by special instructions. These precautions are intended for the personal safety of you and those working with you.

Read and understand all the safety messages in this manual before you operate or service the machine.

**!** DANGER indicates a hazardous situation which, if not avoided, will result in death or serious injury. The color associated with DANGER is RED.

**!** WARNING indicates a hazardous situation which, if not avoided, could result in death or serious injury. The color associated with WARNING is ORANGE.

**!** CAUTION, used with the safety alert symbol, indicates a hazardous situation which, if not avoided, could result in minor or moderate injury. The color associated with CAUTION is YELLOW.

### **FAILURE TO FOLLOW DANGER, WARNING, AND CAUTION MESSAGES COULD RESULT IN DEATH OR SERIOUS INJURY.**

### Machine safety

**NOTICE:** Notice indicates a situation which, if not avoided, could result in machine or property damage. The color associated with Notice is BLUE.

Throughout this manual you will find the signal word Notice followed by special instructions to prevent machine or property damage. The word Notice is used to address practices not related to personal safety.

### Information

**NOTE:** Note indicates additional information which clarifies steps, procedures, or other information in this manual.

Throughout this manual you will find the word Note followed by additional information about a step, procedure, or other information in the manual. The word Note is not intended to address personal safety or property damage.

---

## **Basic instructions - Important notice regarding equipment servicing**

All repair and maintenance work listed in this manual must be carried out only by qualified dealership personnel, strictly complying with the instructions given, and using, whenever possible, the special tools.

Anyone who performs repair and maintenance operations without complying with the procedures provided herein shall be responsible for any subsequent damages.

The manufacturer and all the organizations of its distribution chain, including - without limitation - national, regional, or local dealers, reject any responsibility for damages caused by parts and/or components not approved by the manufacturer, including those used for the servicing or repair of the product manufactured or marketed by the manufacturer. In any case, no warranty is given or attributed on the product manufactured or marketed by the manufacturer in case of damages caused by parts and/or components not approved by the manufacturer.

The information in this manual is up-to-date at the date of the publication. It is the policy of the manufacturer for continuous improvement. Some information could not be updated due to modifications of a technical or commercial type, or changes to the laws and regulations of different countries.

In case of questions, refer to your CNH Sales and Service Networks.

## Torque - Minimum tightening torques for normal assembly

### METRIC NON-FLANGED HARDWARE

NOM. SIZE	CLASS 8.8 BOLT and CLASS 8 NUT		CLASS 10.9 BOLT and CLASS 10 NUT		LOCKNUT CL.8 W/CL8.8 BOLT	LOCKNUT CL.10 W/CL10.9 BOLT
	UNPLATED	PLATED W/ZnCr	UNPLATED	PLATED W/ZnCr		
M4	2.2 N·m (19 lb in)	2.9 N·m (26 lb in)	3.2 N·m (28 lb in)	4.2 N·m (37 lb in)	2 N·m (18 lb in)	2.9 N·m (26 lb in)
M5	4.5 N·m (40 lb in)	5.9 N·m (52 lb in)	6.4 N·m (57 lb in)	8.5 N·m (75 lb in)	4 N·m (36 lb in)	5.8 N·m (51 lb in)
M6	7.5 N·m (66 lb in)	10 N·m (89 lb in)	11 N·m (96 lb in)	15 N·m (128 lb in)	6.8 N·m (60 lb in)	10 N·m (89 lb in)
M8	18 N·m (163 lb in)	25 N·m (217 lb in)	26 N·m (234 lb in)	35 N·m (311 lb in)	17 N·m (151 lb in)	24 N·m (212 lb in)
M10	37 N·m (27 lb ft)	49 N·m (36 lb ft)	52 N·m (38 lb ft)	70 N·m (51 lb ft)	33 N·m (25 lb ft)	48 N·m (35 lb ft)
M12	64 N·m (47 lb ft)	85 N·m (63 lb ft)	91 N·m (67 lb ft)	121 N·m (90 lb ft)	58 N·m (43 lb ft)	83 N·m (61 lb ft)
M16	158 N·m (116 lb ft)	210 N·m (155 lb ft)	225 N·m (166 lb ft)	301 N·m (222 lb ft)	143 N·m (106 lb ft)	205 N·m (151 lb ft)
M20	319 N·m (235 lb ft)	425 N·m (313 lb ft)	440 N·m (325 lb ft)	587 N·m (433 lb ft)	290 N·m (214 lb ft)	400 N·m (295 lb ft)
M24	551 N·m (410 lb ft)	735 N·m (500 lb ft)	762 N·m (560 lb ft)	1016 N·m (750 lb ft)	501 N·m (370 lb ft)	693 N·m (510 lb ft)

**NOTE:** M4 through M8 hardware torque specifications are shown in pound-inches. M10 through M24 hardware torque specifications are shown in pound-feet.

**METRIC FLANGED HARDWARE**

NOM. SIZE	CLASS 8.8 BOLT and CLASS 8 NUT		CLASS 10.9 BOLT and CLASS 10 NUT		LOCKNUT CL.8 W/CL8.8 BOLT	LOCKNUT CL.10 W/CL10.9 BOLT
	UNPLATED	PLATED W/ZnCr	UNPLATED	PLATED W/ZnCr		
M4	2.4 N·m (21 lb in)	3.2 N·m (28 lb in)	3.5 N·m (31 lb in)	4.6 N·m (41 lb in)	2.2 N·m (19 lb in)	3.1 N·m (27 lb in)
M5	4.9 N·m (43 lb in)	6.5 N·m (58 lb in)	7.0 N·m (62 lb in)	9.4 N·m (83 lb in)	4.4 N·m (39 lb in)	6.4 N·m (57 lb in)
M6	8.3 N·m (73 lb in)	11 N·m (96 lb in)	12 N·m (105 lb in)	16 N·m (141 lb in)	7.5 N·m (66 lb in)	11 N·m (96 lb in)
M8	20 N·m (179 lb in)	27 N·m (240 lb in)	29 N·m (257 lb in)	39 N·m (343 lb in)	18 N·m (163 lb in)	27 N·m (240 lb in)
M10	40 N·m (30 lb ft)	54 N·m (40 lb ft)	57 N·m (42 lb ft)	77 N·m (56 lb ft)	37 N·m (27 lb ft)	53 N·m (39 lb ft)
M12	70 N·m (52 lb ft)	93 N·m (69 lb ft)	100 N·m (74 lb ft)	134 N·m (98 lb ft)	63 N·m (47 lb ft)	91 N·m (67 lb ft)
M16	174 N·m (128 lb ft)	231 N·m (171 lb ft)	248 N·m (183 lb ft)	331 N·m (244 lb ft)	158 N·m (116 lb ft)	226 N·m (167 lb ft)
M20	350 N·m (259 lb ft)	467 N·m (345 lb ft)	484 N·m (357 lb ft)	645 N·m (476 lb ft)	318 N·m (235 lb ft)	440 N·m (325 lb ft)
M24	607 N·m (447 lb ft)	809 N·m (597 lb ft)	838 N·m (618 lb ft)	1118 N·m (824 lb ft)	552 N·m (407 lb ft)	

**IDENTIFICATION**

**Metric Hex head and carriage bolts, classes 5.6 and up**

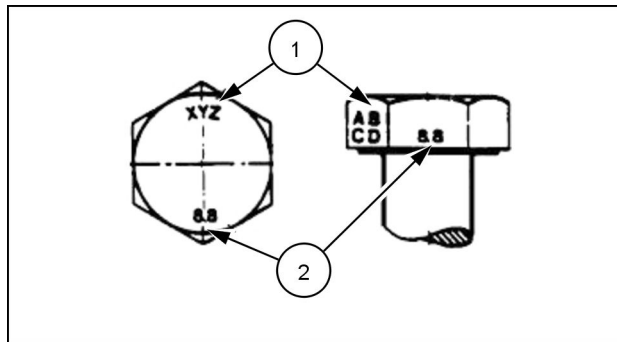

20083680 1

1. Manufacturer's Identification
2. Property Class

**Metric Hex nuts and locknuts, classes 05 and up**

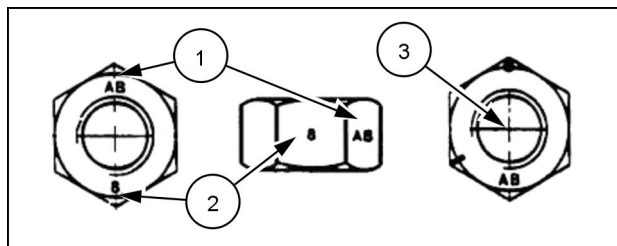

20083681 2

1. Manufacturer's Identification
2. Property Class
3. Clock Marking of Property Class and Manufacturer's Identification (Optional), i.e. marks **60** ° apart indicate Class 10 properties, and marks **120** ° apart indicate Class 8.

**INCH NON-FLANGED HARDWARE**

NOMINAL SIZE	SAE GRADE 5 BOLT and NUT		SAE GRADE 8 BOLT and NUT		LOCKNUT GrB W/ Gr5 BOLT	LOCKNUT GrC W/ Gr8 BOLT
	UN-PLATED or PLATED SILVER	PLATED W/ZnCr GOLD	UN-PLATED or PLATED SILVER	PLATED W/ZnCr GOLD		
1/4	8 N·m (71 lb in)	11 N·m (97 lb in)	12 N·m (106 lb in)	16 N·m (142 lb in)	8.5 N·m (75 lb in)	12.2 N·m (109 lb in)
5/16	17 N·m (150 lb in)	23 N·m (204 lb in)	24 N·m (212 lb in)	32 N·m (283 lb in)	17.5 N·m (155 lb in)	25 N·m (220 lb in)
3/8	30 N·m (22 lb ft)	40 N·m (30 lb ft)	43 N·m (31 lb ft)	57 N·m (42 lb ft)	31 N·m (23 lb ft)	44 N·m (33 lb ft)
7/16	48 N·m (36 lb ft)	65 N·m (48 lb ft)	68 N·m (50 lb ft)	91 N·m (67 lb ft)	50 N·m (37 lb ft)	71 N·m (53 lb ft)
1/2	74 N·m (54 lb ft)	98 N·m (73 lb ft)	104 N·m (77 lb ft)	139 N·m (103 lb ft)	76 N·m (56 lb ft)	108 N·m (80 lb ft)
9/16	107 N·m (79 lb ft)	142 N·m (105 lb ft)	150 N·m (111 lb ft)	201 N·m (148 lb ft)	111 N·m (82 lb ft)	156 N·m (115 lb ft)
5/8	147 N·m (108 lb ft)	196 N·m (145 lb ft)	208 N·m (153 lb ft)	277 N·m (204 lb ft)	153 N·m (113 lb ft)	215 N·m (159 lb ft)
3/4	261 N·m (193 lb ft)	348 N·m (257 lb ft)	369 N·m (272 lb ft)	491 N·m (362 lb ft)	271 N·m (200 lb ft)	383 N·m (282 lb ft)
7/8	420 N·m (310 lb ft)	561 N·m (413 lb ft)	594 N·m (438 lb ft)	791 N·m (584 lb ft)	437 N·m (323 lb ft)	617 N·m (455 lb ft)
1	630 N·m (465 lb ft)	841 N·m (620 lb ft)	890 N·m (656 lb ft)	1187 N·m (875 lb ft)	654 N·m (483 lb ft)	924 N·m (681 lb ft)

**NOTE:** For Imperial Units, *1/4 in* and *5/16 in* hardware torque specifications are shown in pound-inches. *3/8 in* through *1 in* hardware torque specifications are shown in pound-feet.

**INCH FLANGED HARDWARE**

NOM- INAL SIZE	SAE GRADE 5 BOLT and NUT		SAE GRADE 8 BOLT and NUT		LOCKNUT GrF W/ Gr5 BOLT	LOCKNUT GrG W/ Gr8 BOLT
	UNPLATED or PLATED SILVER	PLATED W/ZnCr GOLD	UNPLATED or PLATED SILVER	PLATED W/ZnCr GOLD		
1/4	9 N·m (80 lb in)	12 N·m (106 lb in)	13 N·m (115 lb in)	17 N·m (150 lb in)	8 N·m (71 lb in)	12 N·m (106 lb in)
5/16	19 N·m (168 lb in)	25 N·m (221 lb in)	26 N·m (230 lb in)	35 N·m (310 lb in)	17 N·m (150 lb in)	24 N·m (212 lb in)
3/8	33 N·m (25 lb ft)	44 N·m (33 lb ft)	47 N·m (35 lb ft)	63 N·m (46 lb ft)	30 N·m (22 lb ft)	43 N·m (32 lb ft)
7/16	53 N·m (39 lb ft)	71 N·m (52 lb ft)	75 N·m (55 lb ft)	100 N·m (74 lb ft)	48 N·m (35 lb ft)	68 N·m (50 lb ft)
1/2	81 N·m (60 lb ft)	108 N·m (80 lb ft)	115 N·m (85 lb ft)	153 N·m (113 lb ft)	74 N·m (55 lb ft)	104 N·m (77 lb ft)
9/16	117 N·m (86 lb ft)	156 N·m (115 lb ft)	165 N·m (122 lb ft)	221 N·m (163 lb ft)	106 N·m (78 lb ft)	157 N·m (116 lb ft)
5/8	162 N·m (119 lb ft)	216 N·m (159 lb ft)	228 N·m (168 lb ft)	304 N·m (225 lb ft)	147 N·m (108 lb ft)	207 N·m (153 lb ft)
3/4	287 N·m (212 lb ft)	383 N·m (282 lb ft)	405 N·m (299 lb ft)	541 N·m (399 lb ft)	261 N·m (193 lb ft)	369 N·m (272 lb ft)
7/8	462 N·m (341 lb ft)	617 N·m (455 lb ft)	653 N·m (482 lb ft)	871 N·m (642 lb ft)	421 N·m (311 lb ft)	594 N·m (438 lb ft)
1	693 N·m (512 lb ft)	925 N·m (682 lb ft)	979 N·m (722 lb ft)	1305 N·m (963 lb ft)	631 N·m (465 lb ft)	890 N·m (656 lb ft)

**IDENTIFICATION**

**Inch Bolts and free-spinning nuts**

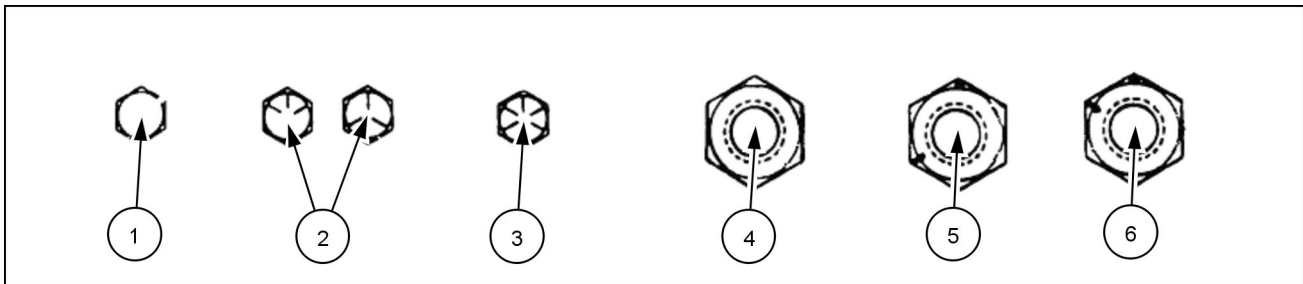

20083682 3

**Grade Marking Examples**

SAE Grade Identification			
1	Grade 2 - No Marks	4	Grade 2 Nut - No Marks
2	Grade 5 - Three Marks	5	Grade 5 Nut - Marks 120 ° Apart
3	Grade 8 - Five Marks	6	Grade 8 Nut - Marks 60 ° Apart

**Inch Lock Nuts, All Metal (Three optional methods)**

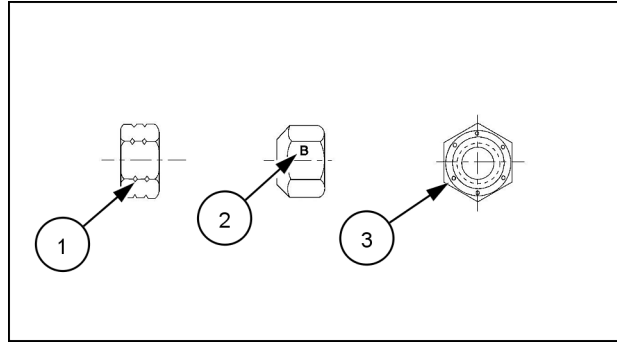

20090268 4

**Grade Identification**

Grade	Corner Marking Method (1)	Flats Marking Method (2)	Clock Marking Method (3)
Grade A	No Notches	No Mark	No Marks
Grade B	One Circumferential Notch	Letter B	Three Marks
Grade C	Two Circumferential Notches	Letter C	Six Marks

## Basic instructions - Shop and assembly

### Shimming

For each adjustment operation, select adjusting shims and measure individually using a micrometer, then add up the recorded values. Do not rely on measuring the entire shimming set, which may be incorrect, or the rated value indicated on each shim.

### Rotating shaft seals

For correct rotating shaft seal installation, proceed as follows:

- Before assembly, allow the seal to soak in the oil it will be sealing for at least thirty minutes.
- Thoroughly clean the shaft and check that the working surface on the shaft is not damaged.
- Position the sealing lip facing the fluid; with hydrodynamic lips, take into consideration the shaft rotation direction and position the grooves so that they will deviate the fluid towards the inner side of the seal.
- Coat the sealing lip with a thin layer of lubricant (use oil rather than grease) and fill the gap between the sealing lip and the dust lip on double lip seals with grease unless instructed otherwise.
- Insert the seal in its seat and press down using a flat punch or seal installation tool. Do not tap the seal with a hammer or mallet.
- While inserting the seal, check that it is perpendicular to the seat; once settled, make sure that it makes contact with the thrust element, if required.
- To prevent damaging the seal lip on the shaft, position a protective guard during installation operations.

### O-ring seals

Lubricate the O-ring seals before inserting them in the seats, this will prevent them from overturning and twisting, which would jeopardize sealing efficiency.

### Sealing compounds

Apply one of the following sealing compounds on the mating surfaces when specified: SILMATE® RTV1473, or **LOCTITE® RTV 598** or **LOCTITE® INSTANT GASKET 587 BLUE**. Before applying the sealing compound, prepare the surfaces as directed on product container or as follows:

- Remove any incrustations using a metal brush.
- Thoroughly de-grease the surfaces using a locally approved cleaning agent such as safety solvent or brake parts cleaner.

### Spare parts

Only use "CNH Original Parts" or "CNH Parts".

Only genuine spare parts guarantee the same quality, duration and safety as original parts, as they are the same parts that are assembled during standard production. Only "CNH Original Parts" or "CNH Parts" can offer this guarantee.

When ordering spare parts, always provide the following information:

- Machine model (commercial name) and serial number
- Part number of the ordered part, which can be found in the "Service Parts Catalogue", used for order processing



---

## Protecting the electrical/electronic systems during charging or welding

### **⚠ WARNING**

**Battery acid causes burns. Batteries contain sulfuric acid.**

**Avoid contact with skin, eyes or clothing. Antidote (external): Flush with water. Antidote (eyes): flush with water for 15 minutes and seek medical attention immediately. Antidote (internal): Drink large quantities of water or milk. Do not induce vomiting. Seek medical attention immediately.**

**Failure to comply could result in death or serious injury.**

W0111A

To avoid damage to the electronic/electrical systems, always observe the following:

1. Never make or break any of the charging circuit connections, including the battery connections, when the engine is running.
2. Never short any of the charging components to ground.
3. Always disconnect the ground cable from the battery before arc welding on the machine or on any attachments on the machine.
  - Position the welder ground clamp as close to the welding area as possible
  - If welding in close proximity to a computer module, then the module should be removed from the machine
  - Never allow welding cables to lay on, near or across any electrical wiring or electronic component while welding is in progress
4. Always disconnect the negative cable from the battery when charging the battery in the machine with a battery charger.

**NOTICE:** *If welding must be performed on the unit, the battery ground cable must be disconnected from the machine battery. The electronic monitoring system and charging system will be damaged if this is not done.*

Remove the battery ground cable. Reconnect the cable when welding is completed.

### **Tools**

The tools that CNH suggests and illustrated in this manual have been:

- Specifically researched and designed for use with CNH machines
- Essential for reliable repair operations
- Accurately built and rigorously tested so as to offer efficient and long-lasting operation

By using these tools, repair personnel will benefit from:

- Operating in optimal technical conditions
- Obtaining the best results
- Saving time and effort
- Working in safe conditions

**NOTE:** *The terms "front", "rear", "right-hand" and "left-hand" (when referred to different parts) are determined from the rear, facing in the direction of travel of the machine during operation.*

---

## General specification - Biodiesel Fuels

Fatty Acid Methyl Ester Biodiesel (Biodiesel Fuel) consists of a family of fuels derived from vegetable oils treated with methyl esters.

**NOTICE:** *Biodiesel Fuel blends are approved for your engine only if they comply with **EN14214** Specification Standards or **ASTM D6751**.*

**NOTICE:** *It is imperative that you check which blend is approved for your engine with your CNH dealer. Be aware that the use of Biodiesel Fuel that does not comply with the Standards mentioned above could lead to severe damage to the engine and fuel system of your machine. The use of fuels that are not approved may void CNH Warranty coverage.*

### Biodiesel Fuel Usage Conditions

**NOTICE:** *The Biodiesel Fuel must meet the fuel Specification mentioned above.*

Biodiesel Fuel must be purchased from a trusted supplier that understands the product and maintains good fuel quality. Biodiesel Fuel must be pre-blended by the supplier. Mixing Biodiesel Fuels on-site can result incorrect mixture that can lead to problems with both engine and fuel system.

Engine performance is affected by the use of Biodiesel Fuel. There may be up to **12 %** reduction in power or torque depending on the blend used.

**NOTICE:** *DO NOT modify the engine and/or injection pump settings to recover the reduced performance.*

The reduced power must be accepted if using any Biodiesel Fuel blend.

Some modification may be required to allow your engine to run Biodiesel Fuel. Consult you dealer for complete information on these modifications.

Biodiesel Fuel has a higher cloud point than Diesel Fuel.

**NOTICE:** *The use of high Biodiesel Fuel blends are not recommended in cold weather conditions.*

With Biodiesel Fuels, it may be necessary to change the engine oil, engine oil filter and fuel filter elements more frequently than with Diesel Fuels. Biodiesel Fuel can remove rust and particles from the inside of on-site fuel storage tanks that would normally adhere to the sides of the tank. Like particle deposits that commonly occur with Diesel Fuel, these particles can become trapped by the machine fuel filters, causing blockage and shortening filter life. In cold weather, this is more likely to happen. Consult your CNH dealer for information on cold weather operation and proper maintenance intervals when using any Biodiesel Fuel blend.

When handling Biodiesel Fuel, care must be taken not to allow water into the fuel supply. Biodiesel Fuel will actually attract moisture from the atmosphere.

Fuel tanks must be kept as full as possible to limit the amount of air and water vapors in them. It may be necessary to drain the fuel filter water tap more frequently.

Potential oxidation and stability could be a problem with the fuel stored in the machine.

**NOTICE:** *Machines must not be stored for more than three months with Biodiesel Fuel blends in the fuel system.*

If long storage periods are necessary, the engine must run on Diesel Fuel for 20 hours to flush the Biodiesel Fuel out of the engine fuel system prior to storage.

**NOTICE:** *Biodiesel Fuel must not be stored in on-site storage tanks for more than three months.*

Any spillage of Biodiesel Fuel must be cleaned up immediately before it can cause damage to the environment and the paint finish of the machine.

Before using Biodiesel Fuel blends you should consult with your dealer to receive full information about the approved blend for your machine and any detailed conditions of its usage.

**NOTICE:** *Be aware that not fulfilling the requirements and conditions of Biodiesel Fuel usage will void your machine's CNH Warranty coverage.*

---

## General specification - General Welding

### **⚠ WARNING**

**Explosion hazard!**

**Batteries emit explosive gases. Always ventilate when using in an enclosed area or when charging.**

**Keep the battery away from sparks, open flames, and other ignition sources.**

**Failure to comply could result in death or serious injury.**

W0369A

Use a 7013 or 7011 welding rod or wire that meets the following American Welding Society (AWS) specifications: ER80S-D2, ER70S-6 or E70C-M6-H4.

**NOTICE:** *ALWAYS disconnect the battery (both terminals) before welding on any part of the machine. Failure to do so may cause damage to sensitive electrical components.*

**NOTICE:** *Locate the welding ground as close as possible to the area to be welded. Do not allow the ground current to pass through any roller type bearing. Arcing inside the roller bearing can result in severe machine damage.*

---

## Product identification

### Engine serial number location

The engine serial number (1) is stamped on the label of the upper side of the rocker cover.

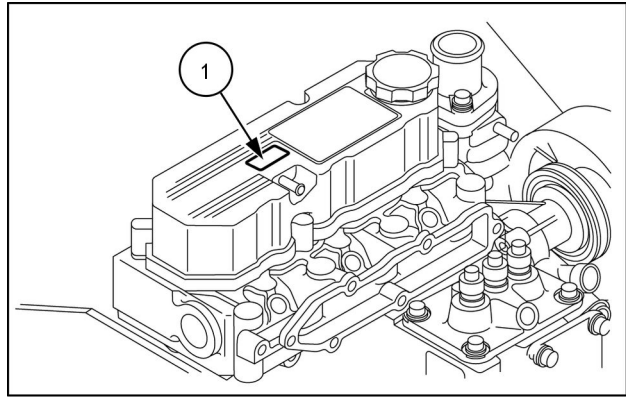

83114967 1

## SERVICE MANUAL

### Engine

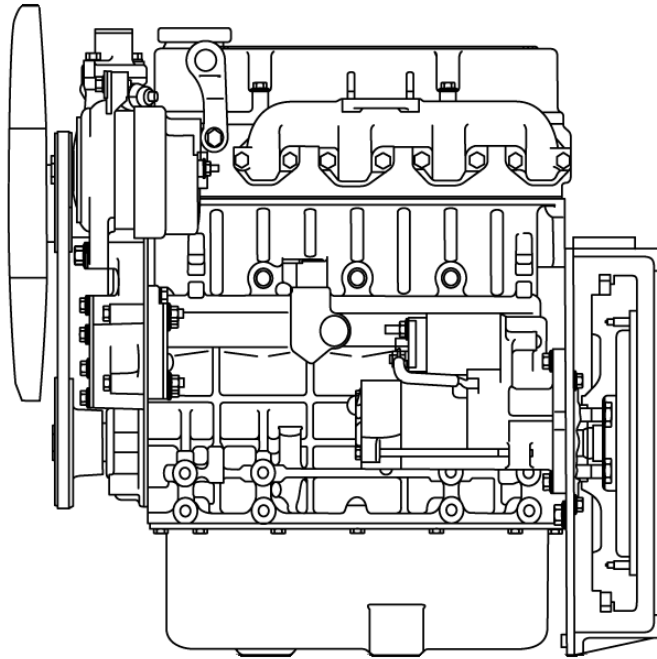

**S3L2**

# Contents

---

## Engine - 10

[10.001] Engine and crankcase .....	10.1
[10.101] Cylinder heads .....	10.2
[10.102] Pan and covers .....	10.3
[10.103] Crankshaft and flywheel.....	10.4
[10.105] Connecting rods and pistons .....	10.5
[10.106] Valve drive and gears .....	10.6
[10.114] Pump drives .....	10.7
[10.206] Fuel filters .....	10.8
[10.218] Fuel injection system.....	10.9
[10.220] Throttle linkage.....	10.10
[10.254] Intake and exhaust manifolds and muffler .....	10.11
[10.304] Engine lubrication system.....	10.12
[10.400] Engine cooling system .....	10.13
[10.414] Fan and drive .....	10.14



## **Engine - 10**

### **Engine and crankcase - 001**

**S3L2**

# Contents

---

## Engine - 10

### Engine and crankcase - 001

#### TECHNICAL DATA

Engine	
General specification .....	3
Torque .....	7

#### FUNCTIONAL DATA

Engine	
Overview .....	8
Exploded view .....	10

#### SERVICE

Engine	
Start up Break-in operation .....	11
Service instruction General Troubleshooting Information .....	13
Check - Compression pressure .....	14
Crankcase	
Measure .....	15

#### DIAGNOSTIC

Engine	
Problem solving .....	16
Testing - Compression pressure .....	17
Testing .....	18



Thank you so much for reading.  
Please click the “Buy Now!”  
button below to download the  
complete manual.



After you pay.

You can download the most  
perfect and complete manual in  
the world immediately.

Our support email:

[ebooklibonline@outlook.com](mailto:ebooklibonline@outlook.com)