

**F4CE9484 / F4CE9487A / F4CE9487N /
F4CE9684 / F4DE9484 / F4DE9684B*JI11 /
F4DE9684M*JI01 / F4DE9684M*JI03 /
F4DE9684 / F4DE9687 / F4GE9484C*J601 /
F4GE9484 / F4GE9684 / F4HE0484G*JI02 /
F4HE0484G*JI09 / F4HE9484C*JI02 /
F4HE9484C*JI03 / F4HE9484 / F4HE9684 /
F4HE9687G*JI00 / F4HE9687
NEF Tier 3
Engine**

SERVICE MANUAL

Part number 47597665

1st edition English

October 2013

CASE II
AGRICULTURE

Mechanical fuel injection / Structural engine block

F4CE9454H*J601	F4CE9484J*J602	F4CE9484M*J603	F4CE9487M*J605	F4CE9684J*J601
F4CE9454H*J605	F4CE9484J*J604	F4CE9484M*J606	F4CE9487N*J601	F4CE9684J*J606
F4CE9484A*J600	F4CE9484L*J600	F4CE9484M*J607	F4CE9487N*J602	F4CE9684J*J607
F4CE9484A*J602	F4CE9484L*J602	F4CE9484M*J608	F4CE9487N*J603	F4CE9684J*J609
F4CE9484C*J600	F4CE9484L*J603	F4CE9484N*J601	F4CE9487N*J605	F4CE9684K*J601
F4CE9484C*J601	F4CE9484L*J604	F4CE9484N*J604	F4CE9487N*J606	F4CE9684K*J606
F4CE9484G*J600	F4CE9484L*J605	F4CE9487A*J600	F4CE9684B*J600	F4CE9684K*J607
F4CE9484G*J604	F4CE9484L*J606	F4CE9487A*J601	F4CE9684C*J600	F4CE9684K*J608
F4CE9484G*J607	F4CE9484M*J601	F4CE9487M*J602	F4CE9684H*J603	F4CE9684L*J600
F4CE9484G*J608	F4CE9484M*J602	F4CE9487M*J603	F4CE9684H*J604	F4CE9684L*J605

Mechanical fuel injection / Non-structural engine block

F4GE9454C*J601	F4GE9484C*J603	F4GE9484F*J615	F4GE9684C*J602	F4GE9684F*J604
F4GE9454C*J602	F4GE9484C*J605	F4GE9484H*J600	F4GE9684D*J600	F4GE9684G*J600
F4GE9454C*J607	F4GE9484C*J606	F4GE9484J*J600	F4GE9684D*J603	F4GE9684G*J601
F4GE9454C*J608	F4GE9484C*J607	F4GE9484J*J601	F4GE9684D*J604	F4GE9684G*J602
F4GE9454J*J605	F4GE9484D*J600	F4GE9484J*J603	F4GE9684E*J600	F4GE9684G*J603
F4GE9454J*J607	F4GE9484D*J603	F4GE9484J*J604	F4GE9684E*J601	F4GE9684G*J605
F4GE9454K*J602	F4GE9484D*J606	F4GE9484J*J605	F4GE9684E*J603	F4GE9684G*J606
F4GE9454K*J604	F4GE9484D*J607	F4GE9484P*J600	F4GE9684E*J604	F4GE9684H*J600
F4GE9454K*J605	F4GE9484D*J617	F4GE9484P*J601	F4GE9684E*J605	F4GE9684H*J601
F4GE9484A*J602	F4GE9484D*J618	F4GE9684A*J603	F4GE9684E*J606	F4GE9684R*J600
F4GE9484A*J605	F4GE9484D*J619	F4GE9684A*J605	F4GE9684E*J607	F4GE9684R*J601
F4GE9484A*J607	F4GE9484D*J620	F4GE9684B*J601	F4GE9684E*J610	F4GE9684R*J602
F4GE9484A*J608	F4GE9484E*J600	F4GE9684B*J602	F4GE9684E*J611	F4GE9684R*J603
F4GE9484A*J610	F4GE9484E*J601	F4GE9684B*J604	F4GE9684E*J612	F4GE9684R*J605
F4GE9484A*J611	F4GE9484E*J602	F4GE9684B*J605	F4GE9684E*J613	F4GE9684R*J606
F4GE9484A*J612	F4GE9484E*J603	F4GE9684B*J606	F4GE9684E*J615	
F4GE9484C*J600	F4GE9484F*J600	F4GE9684B*J607	F4GE9684F*J600	
F4GE9484C*J601	F4GE9484F*J610	F4GE9684C*J600	F4GE9684F*J602	
F4GE9484C*J602	F4GE9484F*J614	F4GE9684C*J601	F4GE9684F*J603	

Electronic fuel injection / Structural engine block

F4DE0484B*J100	F4DE9684B*J100	F4DE9684J*J101	F4DE9684R*J103	F4DE9687J*J104
F4DE0484C*J100	F4DE9684B*J101	F4DE9684J*J102	F4DE9684R*J104	F4DE9687R*J101
F4DE9484A*J100	F4DE9684B*J102	F4DE9684J*J104	F4DE9684R*J105	F4DE9687U*J100
F4DE9484A*J103	F4DE9684B*J104	F4DE9684J*J105	F4DE9684S*J100	F4DE9687U*J102
F4DE9484A*J104	F4DE9684B*J106	F4DE9684L*J100	F4DE9684S*J103	F4DE9687V*J100
F4DE9484B*J101	F4DE9684B*J107	F4DE9684L*J103	F4DE9684S*J106	F4DE9687V*J101
F4DE9484D*J101	F4DE9684B*J108	F4DE9684L*J106	F4DE9684S*J107	F4DE9687V*J104
F4DE9484E*J100	F4DE9684B*J109	F4DE9684L*J107	F4DE9684U*J100	F4DE9687X*J100
F4DE9484F*J100	F4DE9684B*J110	F4DE9684L*J108	F4DE9684Y*J100	F4DE9687X*J101
F4DE9484F*J101	F4DE9684B*J111	F4DE9684L*J109	F4DE9684Y*J101	F4DE9687X*J102
F4DE9484G*J100	F4DE9684C*J100	F4DE9684M*J100	F4DE9684Y*J102	F4DE9687X*J103
F4DE9484H*J100	F4DE9684D*J100	F4DE9684M*J101	F4DE9684Z*J102	F4DE9687X*J104
F4DE9487A*J103	F4DE9684E*J100	F4DE9684M*J103	F4DE9687A*J100	F4DE9687X*J105
F4DE9487A*J104	F4DE9684F*J100	F4DE9684N*J100	F4DE9687A*J103	F4DE9687X*J106
F4DE9487B*J100	F4DE9684F*J102	F4DE9684N*J104	F4DE9687A*J104	F4DE9687Y*J100
F4DE9487B*J101	F4DE9684G*J100	F4DE9684N*J107	F4DE9687C*J100	F4DE9687Y*J101
F4DE9487C*J100	F4DE9684G*J101	F4DE9684N*J108	F4DE9687J*J100	F4DE9687Y*J102
F4DE9487D*J101	F4DE9684H*J100	F4DE9684R*J100	F4DE9687J*J101	
F4DE9487L*J100	F4DE9684J*J100	F4DE9684R*J102	F4DE9687J*J102	

Electronic fuel injection / Non-structural engine block

F4HE0454D*J102	F4HE9484F*J105	F4HE9684E*J104	F4HE9684S*J102	F4HE9687L*J100
F4HE0454D*J104	F4HE9484F*J106	F4HE9684E*J106	F4HE9684S*J103	F4HE9687L*J101
F4HE0484A*J101	F4HE9484M*J100	F4HE9684E*J107	F4HE9684T*J100	F4HE9687M*J101
F4HE0484A*J103	F4HE9484M*J101	F4HE9684F*J100	F4HE9684T*J101	F4HE9687M*J103
F4HE0484G*J100	F4HE9684B*J100	F4HE9684F*J102	F4HE9684U*J101	F4HE9687M*J104
F4HE0484G*J101	F4HE9684B*J101	F4HE9684F*J103	F4HE9684U*J103	F4HE9687M*J105
F4HE0484G*J102	F4HE9684B*J103	F4HE9684F*J104	F4HE9684V*J102	F4HE9687N*J101
F4HE0484G*J103	F4HE9684B*J104	F4HE9684F*J105	F4HE9684V*J103	F4HE9687N*J103
F4HE0484G*J105	F4HE9684C*J100	F4HE9684F*J107	F4HE9687C*J100	F4HE9687N*J104
F4HE0484G*J106	F4HE9684C*J101	F4HE9684F*J108	F4HE9687C*J101	F4HE9687P*J101
F4HE0484G*J108	F4HE9684C*J102	F4HE9684F*J109	F4HE9687C*J103	F4HE9687Q*J101
F4HE0484G*J109	F4HE9684C*J104	F4HE9684J*J100	F4HE9687F*J100	F4HE9687Q*J103
F4HE0484G*J110	F4HE9684C*J105	F4HE9684J*J101	F4HE9687F*J101	F4HE9687S*J101
F4HE0684T*J100	F4HE9684C*J106	F4HE9684J*J102	F4HE9687G*J100	F4HE9687S*J103
F4HE0684T*J101	F4HE9684D*J100	F4HE9684J*J104	F4HE9687G*J101	F4HE9687S*J104
F4HE0684T*J103	F4HE9684D*J101	F4HE9684J*J106	F4HE9687G*J102	F4HE9687S*J105
F4HE9484C*J100	F4HE9684D*J102	F4HE9684K*J100	F4HE9687G*J104	F4HE9687T*J101
F4HE9484C*J102	F4HE9684D*J103	F4HE9684K*J102	F4HE9687H*J100	F4HE9687T*J103
F4HE9484C*J103	F4HE9684D*J105	F4HE9684L*J101	F4HE9687H*J101	F4HE9687T*J104
F4HE9484C*J104	F4HE9684D*J106	F4HE9684L*J102	F4HE9687H*J102	F4HE9687W*J100
F4HE9484C*J105	F4HE9684D*J107	F4HE9684M*J100	F4HE9687H*J103	F4HE9687W*J101
F4HE9484C*J106	F4HE9684D*J109	F4HE9684M*J101	F4HE9687K*J100	F4HE9687W*J102
F4HE9484C*J107	F4HE9684E*J100	F4HE9684P*J102	F4HE9687K*J101	F4HE9687Z*J100
F4HE9484C*J108	F4HE9684E*J101	F4HE9684P*J103	F4HE9687K*J102	F4HE9687Z*J101
F4HE9484F*J103	F4HE9684E*J102	F4HE9684S*J100	F4HE9687K*J103	
F4HE9484F*J104	F4HE9684E*J103	F4HE9684S*J101	F4HE9687K*J105	

Contents

INTRODUCTION

Engine.....	10
[10.001] Engine and crankcase	10.1
[10.102] Pan and covers	10.2
[10.106] Valve drive and gears	10.3
[10.101] Cylinder heads	10.4
[10.105] Connecting rods and pistons.....	10.5
[10.103] Crankshaft and flywheel.....	10.6
[10.110] Balancer and damper	10.7
[10.114] Pump drives	10.8
[10.210] Lift pump and lines	10.9
[10.206] Fuel filters	10.10
[10.218] Fuel injection system.....	10.11
[10.250] Turbocharger and lines.....	10.12
[10.254] Intake and exhaust manifolds and muffler	10.13
[10.400] Engine cooling system	10.14
[10.414] Fan and drive	10.15
[10.304] Engine lubrication system.....	10.16
[10.408] Oil cooler and lines.....	10.17
Electrical systems.....	55
[55.015] Engine control system.....	55.1
[55.201] Engine starting system.....	55.2
[55.301] Alternator.....	55.3
[55.202] Cold start aid	55.4
[55.010] Fuel injection system.....	55.5
[55.014] Engine intake and exhaust system.....	55.6
[55.012] Engine cooling system	55.7

[55.013] Engine oil system 55.8



INTRODUCTION

Contents

INTRODUCTION

Foreword	3
Safety rules	4
Torque	6
F4DE9484, F4HE9484, F4HE0484G*J109, F4HE0484G*J102, F4HE9484C*J102, F4HE9484C*J103, F4DE9684, F4DE9687, F4HE9684, F4HE9687, F4HE9687G*J100, F4DE9684M*J101, F4DE9684M*J103, F4DE9684B*J111	
Torque	9
F4CE9484, F4GE9484, F4CE9487N, F4CE9487A, F4GE9484C*J601, F4CE9684, F4GE9684	
Special tools	11
F4DE9484, F4HE9484, F4HE0484G*J109, F4HE0484G*J102, F4HE9484C*J102, F4HE9484C*J103, F4DE9684, F4DE9687, F4HE9684, F4HE9687, F4HE9687G*J100, F4DE9684M*J101, F4DE9684M*J103, F4DE9684B*J111	
Special tools	17
F4CE9484, F4GE9484, F4CE9487N, F4CE9487A, F4GE9484C*J601, F4CE9684, F4GE9684	

Foreword

Engine Overhaul

Part of the operations illustrated within this manual can be partially executed while the engine is assembled on the vehicle, depending on the room available for access to the engine and on the equipment application as well.

NOTE: *With regard to the engine disassembly operations, please apply for information consulting the specific manual.*

The following information relates to the engine overhaul operations only for what concerns the different components customizing the engine, according to its specific duties.

In section "General Overhaul", all the operations of engine block overhaul have been contemplated. Therefore the above mentioned section is to be considered as following the part hereby described.

Safety rules

Standard safety prescriptions

Particular attention shall be drawn on some precautions that must be followed absolutely in a standard working area and whose non fulfillment will make any other measure useless or not sufficient to ensure safety to the personnel in charge of maintenance.

Be informed and inform personnel as well of the laws in force regulating safety, providing information documentation available for consultation.

- Keep working areas as clean as possible, ensuring adequate aeration.
- Ensure that working areas are provided with emergency boxes, that must be clearly visible and always provided with adequate sanitary equipment.
- Provide for adequate fire extinguishing means, properly indicated and always having free access. Their efficiency must be checked on a regular basis and the personnel must be trained on intervention methods and priorities.
- Organize and identify specific exit points to evacuate the areas in case of an emergency, providing for adequate indications of the emergency indications of the emergency exit lines.
- Smoking in working areas subject to fire danger must be strictly prohibited.
- Provide warnings throughout adequate boards signaling danger, prohibitions and indications to ensure easy comprehension of the instructions even in case of an emergency.

Prevention of injury

- Do not wear unsuitable clothes for work, with fluttering ends, nor jewels such as and chains when working close to engines and equipment in motion.
- Wear safety gloves and goggles when performing the following operations:
 - filling inhibitors or anti-frost
 - lubrication oil topping or replacement
 - utilization of compressed air or liquids under pressure (pressure allowed < **2 bar (29 psi)**).
- Wear safety helmet when working close to hanging loads or equipment working at head height level.
- Always wear safety shoes and clothes adhering to the body, better if provided with elastics at the ends.
- Use protection cream for hands.
- Change wet clothes as soon as possible.
- In presence of electrical current exceeding **48 - 60 V** verify efficiency of earth and mass electrical connections. Ensure that hands and feet are dry and execute working operations utilizing isolating foot boards. Do not carry out working operations if not trained for.
- Do not smoke nor light up flames close to batteries and to any fuel material.
- Put the dirty rags with oil, diesel fuel or solvents in anti-fire specially provided containers.
- Do not execute any intervention if not provided with necessary instructions.
- Do not use any tool or equipment for any different operation from the ones they've been designed and provided for. Serious injury may occur.
- In case of test or calibration operations requiring engine running, ensure that the area is sufficiently ventilated or utilize specific vacuum equipment to eliminate exhaust gas. Danger: poisoning or death.

During maintenance

- Never open filler cap of cooling system when the engine is hot. Operating pressure would provoke high temperature with serious danger and risk of burn. Wait until the temperature decreases under **50 °C (122 °F)**.
- Never top up an overheated engine with cooler and utilize only appropriate liquids.
- Always operate when the engine is tuned off; when particular circumstances require maintenance intervention on running engine, be aware of all risks involved with such operation.
- Be equipped with adequate and safe containers for drainage operation of engine liquids and exhaust oil.

- Keep the engine clean from oil spills, diesel fuel and or chemical solvents.
- Use of solvents or detergents during maintenance may originate toxic vapors. Always keep working areas ventilated. Whenever necessary wear safety mask.
- Do not leave rags impregnated with flammable substances close to the engine.
- Upon engine start after maintenance, undertake proper preventing actions to stop air suction in case of a runaway speed rate.
- Do not utilize fast screw tightening tools.
- Never disconnect batteries when the engine is running.
- Disconnect batteries before any intervention on the electrical system.
- Disconnect batteries from system before applying a load to them with the battery loader.
- After every intervention, verify that battery clamp polarity is correct and that the clamps are tight and safe from accidental short circuit and oxidation.
- Do not disconnect and connect electrical connections in presence of electrical feed.
- Before proceeding with pipelines disassembly (pneumatic, hydraulic, fuel pipes) verify presence of liquid or air under pressure. Take all necessary precautions bleeding and draining residual pressure or closing dump valves. Always wear adequate safety mask or goggles. Non fulfillment of these precautions may cause serious injury and poisoning.
- Avoid incorrect tightening or out of sequence. Danger: incorrect tightening may seriously damage engine's components, affecting engine's duration.
- Avoid priming from fuel tanks made out of copper alloys and/or with ducts not being provided with filters.
- Do not modify cable wires: their lengths shall not be changed.
- Do not connect to the engine electrical equipment unless specifically approved by Iveco.
- Do not modify fuel systems or hydraulic system unless Iveco specific approval has been released. Any unauthorized modification will compromise warranty assistance and furthermore may affect engine correct working and duration.

For engines equipped with electronic controller:

- Do not execute electric arc welding without having previously removed electronic controller.
- Remove electronic controller in case of any intervention requiring heating over **80 °C (176 °F)** temperature.
- Do not paint the components and the electronic connections.
- Do not vary or alter any data filed in the electronic controller driving the engine. Any manipulation or alteration of electronic components shall totally compromise engine assistance warranty and furthermore may affect engine correct working and duration.

Respect of the Environment

- Respect of the Environment shall be of primary importance: all necessary precautions to ensure personnel's safety and health shall be adopted.
- Be informed and inform personnel as well of the laws in force regulating use and exhaust of liquids and engine drain oil. Provide for adequate board indications and organic specific training courses to ensure that personnel is fully aware of such law prescriptions and of basic preventative safety measures.
- Collect drain oils in adequate specially provided containers with hermetic sealing ensuring that storage is made in specific, properly identified areas that shall be ventilated far from heat sources and not exposed to fire danger,
- Handle the batteries with care, storing them in ventilated environment and within anti-acid containers. Warning: Battery exhalation represent serious danger of intoxication and environment contamination.

Torque

F4DE9484, F4HE9484, F4HE0484G*J109, F4HE0484G*J102, F4HE9484C*J102, F4HE9484C*J103, F4DE9684, F4DE9687, F4HE9684, F4HE9687, F4HE9687G*J100, F4DE9684M*J101, F4DE9684M*J103, F4DE9684B*J111

Component	Size	Specification
Cylinder Head and Components		
Plug	1/4"	10 - 14 Nm (7.4 - 10.3 lb ft)
	1/2"	20 - 28 Nm (14.8 - 20.7 lb ft)
	3/4"	31 - 41 Nm (22.9 - 30.2 lb ft)
Grid Heater	M6 Nut	6 - 10 Nm (4.4 - 7.4 lb ft)
Intake Manifold	M8 Screw	20 - 28 Nm (14.8 - 20.7 lb ft)
Engine Lifting Bracket		
Rear	M12	65 - 89 Nm (47.9 - 65.6 lb ft)
Front	M8	20 - 28 Nm (14.8 - 20.7 lb ft)
Cylinder Head	M12x1.75x130 mm	
First Phase		30 - 40 Nm (22.1 - 29.5 lb ft)
Second Phase		85 - 95 °
Third Phase		85 - 95 °
Cylinder Head	M12x1.75x150 mm	
First Phase		50 - 60 Nm (36.9 - 44.3 lb ft)
Second Phase		85 - 95 °
Third Phase		85 - 95 °
Rocker Bracket		31 - 41 Nm (22.9 - 30.2 lb ft)
Rocker Arm Jam Nuts		20 - 28 Nm (14.8 - 20.7 lb ft)
Exhaust Manifold		48 - 58 Nm (35.4 - 42.8 lb ft)
Valve Cover	M8 Nut	20 - 28 Nm (14.8 - 20.7 lb ft)
Turbocharger		
6 Cylinder	M8 Screw	6 - 8 Nm (4.4 - 5.9 lb ft)
	M8 Nut	37 - 49 Nm (27.3 - 36.1 lb ft)
4 Cylinder	M8 Screw	6 - 8 Nm (4.4 - 5.9 lb ft)
	M8 Nut	20 - 28 Nm (14.8 - 20.7 lb ft)
Front Case		
Front Cover	M8 Screw	20 - 28 Nm (14.8 - 20.7 lb ft)
Rear Case		
Gear Case	M12 Screw	65 - 89 Nm (47.9 - 65.6 lb ft)
	M10 Screw	42 - 52 Nm (31.0 - 38.4 lb ft)
	M8 Screw	20 - 28 Nm (14.8 - 20.7 lb ft)
Flywheel Housing	M10	75 - 95 Nm (55.3 - 70.1 lb ft)
	M12	44 - 54 Nm (32.5 - 39.8 lb ft)
Cylinder Block and Crankshaft Components		

INTRODUCTION

Component	Size	Specification
Camshaft Retaining Plate	M8 Screw	20 - 28 Nm (14.8 - 20.7 lb ft)
Camshaft Gear	M8 Screw	32 - 40 Nm (23.6 - 29.5 lb ft)
Crankcase Plate	M10 Screw	38 - 48 Nm (28.0 - 35.4 lb ft)
Vibration Damper and Adapter	M12	
First Phase		45 - 55 Nm (33.2 - 40.6 lb ft)
Second Phase		90 °
Drive Pulley	M10	61 - 75 Nm (45.0 - 55.3 lb ft)
Engine Flywheel	M12	
First Phase		26 - 34 Nm (19.2 - 25.1 lb ft)
Second Phase		55 - 65 °
Main Caps	M12	
First Phase		44 - 56 Nm (32.5 - 41.3 lb ft)
Second Phase		74 - 86 Nm (54.6 - 63.4 lb ft)
Third Phase		85 - 95 °
Connecting Rod Caps		
First Phase		55 - 65 Nm (40.6 - 47.9 lb ft)
Second Phase		55 - 65 °
Lubrication System and Components		
Oil Pump		
First Phase	M8	7 - 9 Nm (5.2 - 6.6 lb ft)
Second Phase	M8	20 - 28 Nm (14.8 - 20.7 lb ft)
Oil Pressure Relief Valve	M22	72 - 88 Nm (53.1 - 64.9 lb ft)
Oil Cooler and Oil Filter Base	M8 Screw	20 - 28 Nm (14.8 - 20.7 lb ft)
Oil Filter		Contact + ¾ Turn
Connection on Filter Base for Turbo Oil Supply	1 1/8"	20 - 28 Nm (14.8 - 20.7 lb ft)
Turbo Lubrication Pipe	M12 Nut	8 - 12 Nm (5.9 - 8.9 lb ft)
Turbo Lubrication Pipe Adapter	M12	30 - 40 Nm (22.1 - 29.5 lb ft)
Oil Pan		20 - 28 Nm (14.8 - 20.7 lb ft)
Piston Spray Nozzles	M8	12 - 18 Nm (8.9 - 13.3 lb ft)
Electrical Components		
Camshaft Sensor	M6 Studs	6 - 10 Nm (4.4 - 7.4 lb ft)
	M6 Nut	8 - 12 Nm (5.9 - 8.9 lb ft)
	M6 Screw	6 - 10 Nm (4.4 - 7.4 lb ft)
Wiring Bulkhead	M6 Screw	8 - 12 Nm (5.9 - 8.9 lb ft)
Support Bracket for Injector Wiring	M8 Screw	20 - 28 Nm (14.8 - 20.7 lb ft)
Injector Wiring		1.25 - 1.75 Nm (0.92 - 1.29 lb ft)
ECU Cooling Plate	M6 Screw	8 - 12 Nm (5.9 - 8.9 lb ft)
	M8 Screw	20 - 28 Nm (14.8 - 20.7 lb ft)
Fuel Outlet	M12	10 - 14 Nm (7.4 - 10.3 lb ft)
Fuel Inlet	M12	10 - 14 Nm (7.4 - 10.3 lb ft)
Crankshaft Speed Sensor	M6 Screw	6 - 10 Nm (4.4 - 7.4 lb ft)
Coolant Temperature Sensor	M14 Screw	17 - 23 Nm (12.5 - 17.0 lb ft)
Oil Pressure / Temperature Sensor	M5 Screw	5 - 7 Nm (3.7 - 5.2 lb ft)
Fuel Pressure Sensor		30 - 40 Nm (22.1 - 29.5 lb ft)
Fuel Temperature Sensor	M14	17 - 23 Nm (12.5 - 17.0 lb ft)
Air Pressure / Temperature Sensor		5 - 7 Nm (3.7 - 5.2 lb ft)
Engine Oil Level Sensor	M12	10 - 14 Nm (7.4 - 10.3 lb ft)
Alternator Support Bracket	M10 Screw	37 - 49 Nm (27.3 - 36.1 lb ft)
Alternator Tension Bracket	M10 Screw	37 - 49 Nm (27.3 - 36.1 lb ft)
Starter		37 - 49 Nm (27.3 - 36.1 lb ft)
Fuel System and Components		

INTRODUCTION

Component	Size	Specification
Feed Pump	M8 Studs	10 - 14 Nm (7.4 - 10.3 lb ft)
High Pressure Pump Gear	M18 Nut	100 - 110 Nm (73.8 - 81.1 lb ft)
Fuel Pump	M8 Nut	20 - 28 Nm (14.8 - 20.7 lb ft)
Injector		
First Phase	M6 Screw	8.15 - 8.85 Nm (6.0 - 6.5 lb ft)
Second Phase	M6 Screw	70 - 80 °
Injector Feed Connector		45 - 55 Nm (33.2 - 40.6 lb ft)
Common Rail	M8 Screw	20 - 28 Nm (14.8 - 20.7 lb ft)
High Pressure Fuel Line	M14 Fitting	18 - 22 Nm (13.3 - 16.2 lb ft)
High Pressure Pipe Connector	M8 Screw	20 - 28 Nm (14.8 - 20.7 lb ft)
Fuel Filter Bracket	M12 Screw	71 - 85 Nm (52.4 - 62.7 lb ft)
Fuel Filter Holder	M8 Screw	20 - 28 Nm (14.8 - 20.7 lb ft)
Fuel Filter		Contact + ¼ Turn
Cooling System and Components		
Engine Coolant Inlet	M10 Screw	37 - 49 Nm (27.3 - 36.1 lb ft)
Fitting on Coolant Inlet	90 ° Elbow	20 - 28 Nm (14.8 - 20.7 lb ft)
Compressor Cooling Pipe		20 - 24 Nm (14.8 - 17.7 lb ft)
Engine Coolant Drain Collector	M6 Screw	8 - 12 Nm (5.9 - 8.9 lb ft)
Water Pump	M8 Screw	20 - 28 Nm (14.8 - 20.7 lb ft)
Belt Tensioner	M10	37 - 49 Nm (27.3 - 36.1 lb ft)
Idler Pulleys	M10	37 - 49 Nm (27.3 - 36.1 lb ft)

Torque

F4CE9484, F4GE9484, F4CE9487N, F4CE9487A, F4GE9484C*J601, F4CE9684, F4GE9684

Component	Size	Specification
Cylinder Head and Components		
Rocker Assembly	M8	20 - 28 Nm (14.8 - 20.7 lb ft)
Cylinder Head	M12x70	
Phase 1		50 Nm (36.9 lb ft)
Phase 2		90 °
Cylinder Head	M12x140	
Phase 1		40 Nm (29.5 lb ft)
Phase 2		180 °
Cylinder Head	M12x180	
Phase 1		70 Nm (51.6 lb ft)
Phase 2		180 °
Valve Cover	M8x1.25x25	20 - 28 Nm (14.8 - 20.7 lb ft)
Intake manifold	M8x1.25	20 - 28 Nm (14.8 - 20.7 lb ft)
Air intake elbow	M8x1.25	20 - 28 Nm (14.8 - 20.7 lb ft)
Exhaust manifold	M10x1.5x65	37 - 49 Nm (27.3 - 36.1 lb ft)
Rear lifting bracket	M12x1.75x30	65 - 89 Nm (47.9 - 65.6 lb ft)
Turbocharger	M10	37 - 49 Nm (27.3 - 36.1 lb ft)
Front Case		
Front cover assembly	M8x1.25x45	20 - 28 Nm (14.8 - 20.7 lb ft)
	M8x1.25x30	20 - 28 Nm (14.8 - 20.7 lb ft)
Rear Case		
Gear Case	M8x1.25x40	20 - 28 Nm (14.8 - 20.7 lb ft)
	M8x1.25x25	20 - 28 Nm (14.8 - 20.7 lb ft)
	M10x1.5	44 - 54 Nm (32.5 - 39.8 lb ft)
Flywheel housing	M12x120	75 - 95 Nm (55.3 - 70.1 lb ft)
	M12x80	75 - 95 Nm (55.3 - 70.1 lb ft)
	M10x80	44 - 54 Nm (32.5 - 39.8 lb ft)
	M10x40	44 - 54 Nm (32.5 - 39.8 lb ft)
Phase 1	M12x1.25	26 - 34 Nm (19.2 - 25.1 lb ft)
Phase 2	M12x1.25	55 - 65 °
Cylinder Block and Crankshaft Components		
Main bearing cap		
Phase 1		44 - 56 Nm (32.5 - 41.3 lb ft)
Phase 2		74 - 86 Nm (54.6 - 63.4 lb ft)
Phase 3		85 - 95 °
Connecting rod	M11x1.25	
Phase 1		27 - 33 Nm (19.9 - 24.3 lb ft)
Phase 2		55 - 65 Nm (40.6 - 47.9 lb ft)
Phase 3		55 - 65 °
Timing Pin		4 - 6 Nm (3.0 - 4.4 lb ft)
Crankshaft pulley	M12x1.75	105 - 115 Nm (77.4 - 84.8 lb ft)
Camshaft retaining plate	M8	20 - 28 Nm (14.8 - 20.7 lb ft)
Camshaft gear	M8	32 - 40 Nm (23.6 - 29.5 lb ft)
Lubrication System and Components		

INTRODUCTION

Component	Size	Specification
Piston Cooling Nozzles	M8x1.25x10	12 - 18 Nm (8.9 - 13.3 lb ft)
Oil pump	M8x1.25x30	7 - 9 Nm (5.2 - 6.6 lb ft)
Stiffening Plate	M10x1.25x25	38 - 48 Nm (28.0 - 35.4 lb ft)
Oil plug	M10x1	5 - 7 Nm (3.7 - 5.2 lb ft)
	M14x1.5	9 - 13 Nm (6.6 - 9.6 lb ft)
Oil Pick up tube	M8x1.25x20	20 - 28 Nm (14.8 - 20.7 lb ft)
Oil Pan	M8x1.25x25	20 - 28 Nm (14.8 - 20.7 lb ft)
	M18x1.50	51 - 69 Nm (37.6 - 50.9 lb ft)
Oil Bypass Valve	M22x1.5x10	72 - 88 Nm (53.1 - 64.9 lb ft)
Turbo Lubrication Lines		
Turbo end	M12x1.5	20 - 28 Nm (14.8 - 20.7 lb ft)
Filter base end		20 - 28 Nm (14.8 - 20.7 lb ft)
Drain	M8x1.25x16	20 - 28 Nm (14.8 - 20.7 lb ft)
Electrical Components		
Alternator		
	M8x1.25x30	20 - 28 Nm (14.8 - 20.7 lb ft)
	M10x1.25x25	20 - 28 Nm (14.8 - 20.7 lb ft)
	M10	44 - 54 Nm (32.5 - 39.8 lb ft)
	M12x1.75x120	37 - 49 Nm (27.3 - 36.1 lb ft)
Alternator wiring	M6x1.0 nut	8 - 11 Nm (5.9 - 8.1 lb ft)
Starter	M10	54 - 44 Nm (39.8 - 32.5 lb ft)
Fuel System and Components		
Fuel pump	M8 screw	20 - 28 Nm (14.8 - 20.7 lb ft)
	M6 screw	9 - 11 Nm (6.6 - 8.1 lb ft)
	M6 nut	9 - 11 Nm (6.6 - 8.1 lb ft)
Fuel Pump Drive Gear		
Phase 1		15 - 20 Nm (11.1 - 14.8 lb ft)
Phase 2		85 - 90 Nm (62.7 - 66.4 lb ft)
Timing Pin Cap		30 - 35 Nm (22.1 - 25.8 lb ft)
Fuel injectors		55 - 65 Nm (40.6 - 47.9 lb ft)
Fuel lift pump		20 - 28 Nm (14.8 - 20.7 lb ft)
Cooling System and Components		
Water Pump	M8x1.25x25	20 - 28 Nm (14.8 - 20.7 lb ft)
Water outlet connection	M8x1.25x35	20 - 28 Nm (14.8 - 20.7 lb ft)
	M8x1.25x70	20 - 28 Nm (14.8 - 20.7 lb ft)
Fan support	M10x1.5x20	28 - 38 Nm (20.7 - 28.0 lb ft)
Fan pulley	M6	8 - 12 Nm (5.9 - 8.9 lb ft)
	M10	27 - 49 Nm (19.9 - 36.1 lb ft)

Special tools

F4DE9484, F4HE9484, F4HE0484G*J109, F4HE0484G*J102, F4HE9484C*J102, F4HE9484C*J103, F4DE9684, F4DE9687, F4HE9684, F4HE9687, F4HE9687G*J100, F4DE9684M*J101, F4DE9684M*J103, F4DE9684B*J111

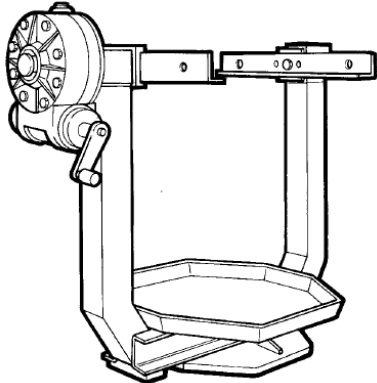
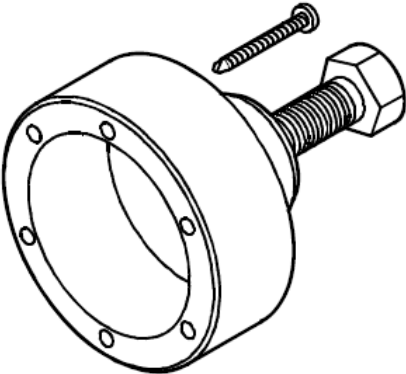
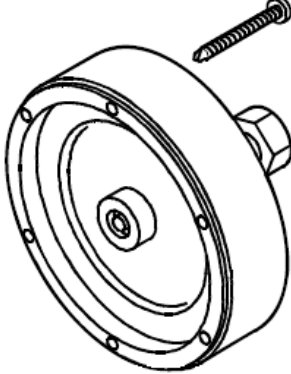
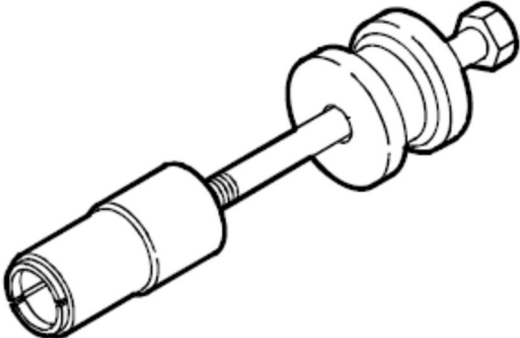
Tool No.	Description	Image
380000301	Revolving engine stand	 <p data-bbox="1054 763 1222 779">REVOLVING STAND 1</p>
380000665	Crankshaft front seal puller	 <p data-bbox="1054 1196 1222 1211">FRONTSEALPULLER 2</p>
380000663	Crankshaft rear seal puller	 <p data-bbox="1054 1628 1222 1644">REARSEALPULLER 3</p>
380001099	Injector puller	 <p data-bbox="1054 2051 1222 2067">INJECTORPULLER 4</p>

INTRODUCTION

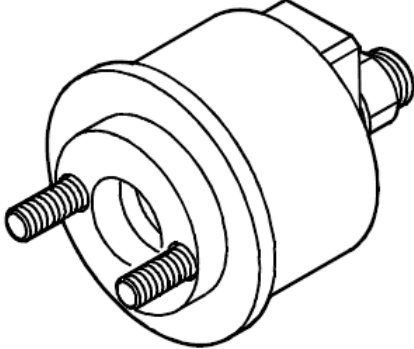
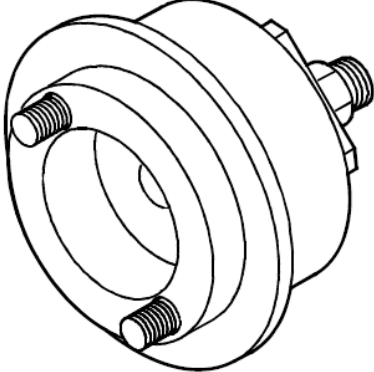
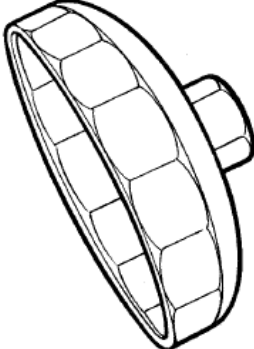
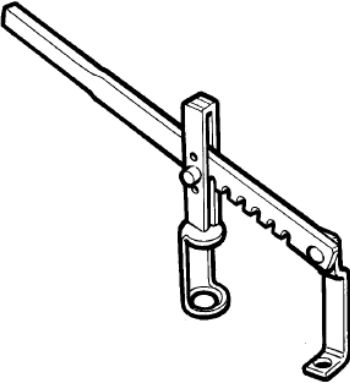
Tool No.	Description	Image
380000666	Crankshaft front seal installer	 <p>FRONTSEALINSTAL 5</p>
380000664	Crankshaft rear seal installer	 <p>CRANKREARSEALIN 6</p>
380000670	Oil filter wrench	 <p>OILFILTERWRENCH 7</p>
380000302	Valve spring compressor	 <p>VALVESPRINGCOMP 8</p>

INTRODUCTION

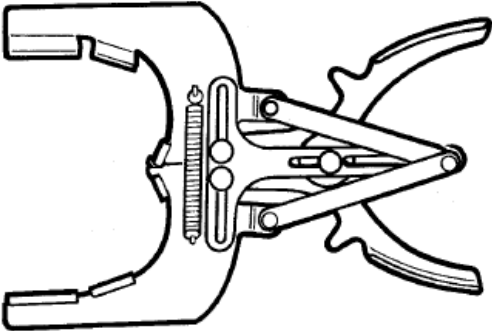
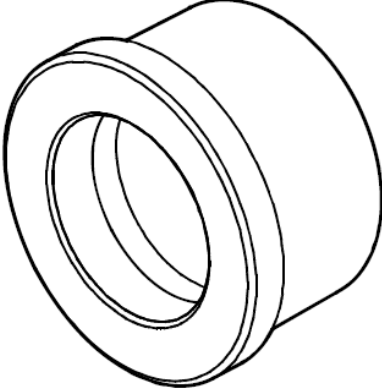
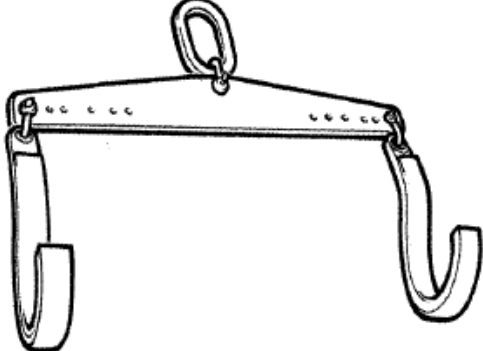
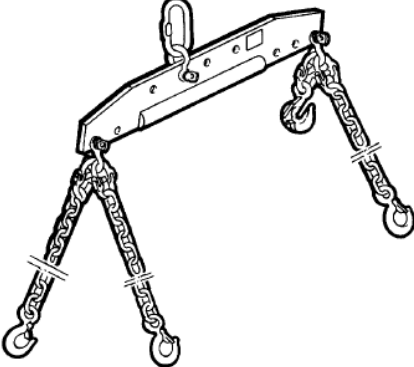
Tool No.	Description	Image
380000221	Pliers for removing/refitting piston rings 65 - 110 mm (2.559 - 4.331 in)	 <p data-bbox="1059 633 1219 651">PISTONRINGPLIER 9</p>
380000667	Beater for removing/refitting camshaft bushes	 <p data-bbox="1059 1066 1219 1084">CAMBUSHBEATER 10</p>
380000362	Tool for lifting the crankshaft	 <p data-bbox="1075 1491 1203 1509">CRANKHOIST 11</p>
380000216	Engine lifting rig	 <p data-bbox="1075 1924 1203 1942">ENGINEHOIST 12</p>

INTRODUCTION

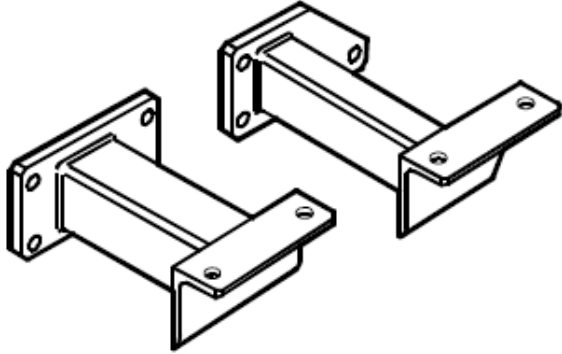
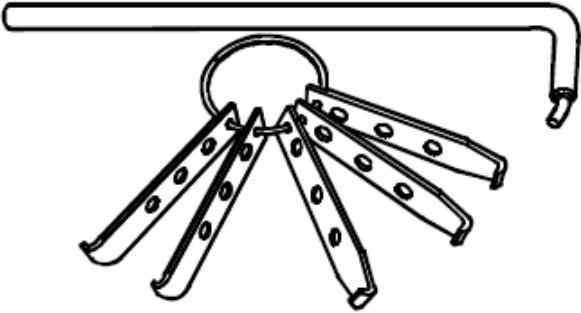
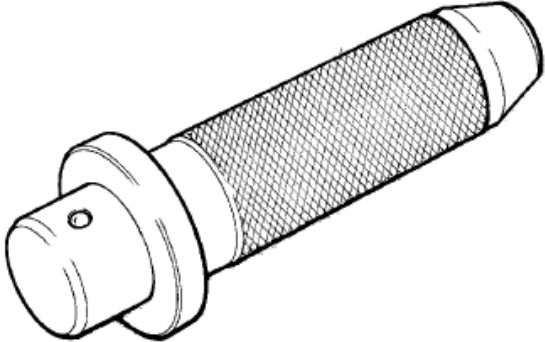
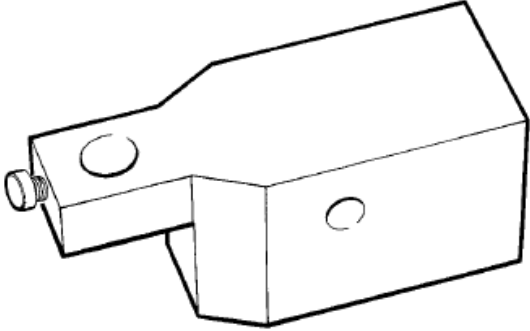
Tool No.	Description	Image
380000661	Brackets for fastening the engine to the revolving stand	 <p data-bbox="1002 633 1169 651">STANDBRACKETS 13</p>
380000669	Seal remover	 <p data-bbox="1011 1052 1161 1070">SEALREMOVER 14</p>
380000668	Hand grip for interchangeable beaters	 <p data-bbox="1027 1480 1145 1498">HANDGRIP 15</p>
380000364	Gauge base for dial indicator	 <p data-bbox="1023 1912 1153 1930">GAUGEBASE 16</p>

Thank you so much for reading.
Please click the “Buy Now!”
button below to download the
complete manual.



After you pay.

You can download the most
perfect and complete manual in
the world immediately.

Our support email:

ebooklibonline@outlook.com