

Patriot[®] 2230
Tier 3
Sprayer

PIN YFT041652 and above

SERVICE MANUAL

Part number 47907916

1st edition English

August 2015

CASE II
AGRICULTURE



SERVICE MANUAL

Patriot® 2230

Link Product / Engine

Product	Market Product	Engine
Patriot® 2230 MY 2016 TIER 3 class 2 rest of world sprayer [YFT041652 -]	Australia New Zealand	F4HFE96872*J101

Contents

INTRODUCTION

Engine.....	10
[10.001] Engine and crankcase	10.1
[10.400] Engine cooling system	10.2
[10.310] Aftercooler.....	10.3
Power coupling.....	19
[19.121] Pump-drive assembly	19.1
Front axle system	25
[25.100] Powered front axle	25.1
[25.122] Axle suspension control.....	25.2
[25.310] Final drives	25.3
Rear axle system.....	27
[27.100] Powered rear axle.....	27.1
[27.120] Planetary and final drives	27.2
Hydrostatic drive.....	29
[29.218] Pump and motor components.....	29.1
Brakes and controls	33
[33.202] Hydraulic service brakes	33.1
[33.110] Parking brake or parking lock	33.2
Hydraulic systems.....	35
[35.000] Hydraulic systems.....	35.1
[35.300] Reservoir, cooler, and filters.....	35.2
[35.104] Fixed displacement pump.....	35.3
[35.106] Variable displacement pump	35.4
[35.911] Sprayer boom hydraulic system.....	35.5
Frames and ballasting	39

[39.130] Sprayer boom	39.1
Steering	41
[41.101] Steering control	41.1
[41.206] Pump	41.2
[41.216] Cylinders	41.3
Wheels	44
[44.511] Front wheels.....	44.1
[44.520] Rear wheels.....	44.2
Cab climate control	50
[50.100] Heating	50.1
[50.200] Air conditioning	50.2
Electrical systems	55
[55.000] Electrical system	55.1
[55.100] Harnesses and connectors.....	55.2
[55.019] Hydrostatic drive control system	55.3
[55.DTC] FAULT CODES.....	55.4
Spraying	78
[78.110] Chemical spraying.....	78.1
[78.111] Spraying pump	78.2
Platform, cab, bodywork, and decals	90
[90.151] Cab interior.....	90.1
[90.105] Machine shields and guards	90.2



INTRODUCTION

Contents

INTRODUCTION

Foreword - Important notice regarding equipment servicing	3
Safety rules	4
Safety rules - Ecology and the environment	5
Basic instructions - Shop and assembly	6
Torque - Minimum tightening torques for normal assembly	8
Torque - Standard torque data for hydraulics	11
Maintenance chart	13
Hydraulic contamination	15
Capacities	16
General specification	17
Product identification	18
Product identification - Machine orientation	19

Foreword - Important notice regarding equipment servicing

All repair and maintenance work listed in this manual must be carried out only by qualified dealership personnel, strictly complying with the instructions given, and using, whenever possible, the special tools.

Anyone who performs repair and maintenance operations without complying with the procedures provided herein shall be responsible for any subsequent damages.

The manufacturer and all the organizations of its distribution chain, including - without limitation - national, regional, or local dealers, reject any responsibility for damages caused by parts and/or components not approved by the manufacturer, including those used for the servicing or repair of the product manufactured or marketed by the manufacturer. In any case, no warranty is given or attributed on the product manufactured or marketed by the manufacturer in case of damages caused by parts and/or components not approved by the manufacturer.

The manufacturer reserves the right to make improvements in design and changes in specifications at any time without notice and without incurring any obligation to install them on units previously sold. Specifications, descriptions, and illustrative material herein are as accurate as known at time of publication but are subject to change without notice.

In case of questions, refer to your CASE IH Sales and Service Networks.

Safety rules

Personal safety





This is the safety alert symbol. It is used to alert you to potential personal injury hazards. Obey all safety messages that follow this symbol to avoid possible death or injury.

Throughout this manual you will find the signal words DANGER, WARNING, and CAUTION followed by special instructions. These precautions are intended for the personal safety of you and those working with you.

Read and understand all the safety messages in this manual before you operate or service the machine.

 DANGER indicates a hazardous situation that, if not avoided, will result in death or serious injury.

 WARNING indicates a hazardous situation that, if not avoided, could result in death or serious injury.

 CAUTION indicates a hazardous situation that, if not avoided, could result in minor or moderate injury.

FAILURE TO FOLLOW DANGER, WARNING, AND CAUTION MESSAGES COULD RESULT IN DEATH OR SERIOUS INJURY.

Machine safety

NOTICE: Notice indicates a situation that, if not avoided, could result in machine or property damage.

Throughout this manual you will find the signal word Notice followed by special instructions to prevent machine or property damage. The word Notice is used to address practices not related to personal safety.

Information

NOTE: Note indicates additional information that clarifies steps, procedures, or other information in this manual.

Throughout this manual you will find the word Note followed by additional information about a step, procedure, or other information in the manual. The word Note is not intended to address personal safety or property damage.

Safety rules - Ecology and the environment

Soil, air, and water quality is important for all industries and life in general. When legislation does not yet rule the treatment of some of the substances that advanced technology requires, sound judgment should govern the use and disposal of products of a chemical and petrochemical nature.

Familiarize yourself with the relative legislation applicable to your country, and make sure that you understand this legislation. Where no legislation exists, obtain information from suppliers of oils, filters, batteries, fuels, anti-freeze, cleaning agents, etc., with regard to the effect of these substances on man and nature and how to safely store, use, and dispose of these substances.

Helpful hints

- Avoid the use of cans or other inappropriate pressurized fuel delivery systems to fill tanks. Such delivery systems may cause considerable spillage.
- In general, avoid skin contact with all fuels, oils, acids, solvents, etc. Most of these products contain substances that may be harmful to your health.
- Modern oils contain additives. Do not burn contaminated fuels and or waste oils in ordinary heating systems.
- Avoid spillage when you drain fluids such as used engine coolant mixtures, engine oil, hydraulic fluid, brake fluid, etc. Do not mix drained brake fluids or fuels with lubricants. Store all drained fluids safely until you can dispose of the fluids in a proper way that complies with all local legislation and available resources.
- Do not allow coolant mixtures to get into the soil. Collect and dispose of coolant mixtures properly.
- The air-conditioning system contains gases that should not be released into the atmosphere. Consult an air-conditioning specialist or use a special extractor to recharge the system properly.
- Repair any leaks or defects in the engine cooling system or hydraulic system immediately.
- Do not increase the pressure in a pressurized circuit as this may lead to a component failure.
- Protect hoses during welding. Penetrating weld splatter may burn a hole or weaken hoses, allowing the loss of oils, coolant, etc.

Battery recycling

Batteries and electric accumulators contain several substances that can have a harmful effect on the environment if the batteries are not properly recycled after use. Improper disposal of batteries can contaminate the soil, groundwater, and waterways. CASE IH strongly recommends that you return all used batteries to a CASE IH dealer, who will dispose of the used batteries or recycle the used batteries properly. In some countries, this is a legal requirement.



Mandatory battery recycling

NOTE: The following requirements are mandatory in Brazil.

Batteries are made of lead plates and a sulfuric acid solution. Because batteries contain heavy metals such as lead, CONAMA Resolution 401/2008 requires you to return all used batteries to the battery dealer when you replace any batteries. Do not dispose of batteries in your household garbage.

Points of sale are obliged to:

- Accept the return of your used batteries
- Store the returned batteries in a suitable location
- Send the returned batteries to the battery manufacturer for recycling

Basic instructions - Shop and assembly

Shimming

For each adjustment operation, select adjusting shims and measure the adjusting shims individually using a micrometer, then add up the recorded values. Do not rely on measuring the entire shimming set, which may be incorrect, or the rated value shown on each shim.

Rotating shaft seals

For correct rotating shaft seal installation, proceed as follows:

1. Before assembly, allow the seal to soak in the oil it will be sealing for at least thirty minutes.
2. Thoroughly clean the shaft and check that the working surface on the shaft is not damaged.
3. Position the sealing lip facing the fluid.

NOTE: *With hydrodynamic lips, take into consideration the shaft rotation direction and position the grooves so that they will move the fluid towards the inner side of the seal.*

4. Coat the sealing lip with a thin layer of lubricant (use oil rather than grease). Fill the gap between the sealing lip and the dust lip on double lip seals with grease.
5. Insert the seal in its seat and press down using a flat punch or seal installation tool. Do not tap the seal with a hammer or mallet.
6. While you insert the seal, check that the seal is perpendicular to the seat. When the seal settles, make sure that the seal makes contact with the thrust element, if required.
7. To prevent damage to the seal lip on the shaft, position a protective guard during installation operations.

O-ring seals

Lubricate the O-ring seals before you insert them in the seats. This will prevent the O-ring seals from overturning and twisting, which would jeopardize sealing efficiency.

Sealing compounds

Apply a sealing compound on the mating surfaces when specified by the procedure. Before you apply the sealing compound, prepare the surfaces as directed by the product container.

Spare parts

Only use CNH Original Parts or CASE IH Original Parts.

Only genuine spare parts guarantee the same quality, duration, and safety as original parts, as they are the same parts that are assembled during standard production. Only CNH Original Parts or CASE IH Original Parts can offer this guarantee.

When ordering spare parts, always provide the following information:

- Machine model (commercial name) and Product Identification Number (PIN)
- Part number of the ordered part, which can be found in the parts catalog

Protecting the electronic and/or electrical systems during charging and welding

To avoid damage to the electronic and/or electrical systems, always observe the following practices:

1. Never make or break any of the charging circuit connections when the engine is running, including the battery connections.
2. Never short any of the charging components to ground.
3. Always disconnect the ground cable from the battery before arc welding on the machine or on any machine attachment.
 - Position the welder ground clamp as close to the welding area as possible.
 - If you weld in close proximity to a computer module, then you should remove the module from the machine.
 - Never allow welding cables to lie on, near, or across any electrical wiring or electronic component while you weld.
4. Always disconnect the negative cable from the battery when charging the battery in the machine with a battery charger.

NOTICE: *If you must weld on the unit, you must disconnect the battery ground cable from the machine battery. The electronic monitoring system and charging system will be damaged if this is not done.*

5. Remove the battery ground cable. Reconnect the cable when you complete welding.

⚠ WARNING

Battery acid causes burns. Batteries contain sulfuric acid.

Avoid contact with skin, eyes or clothing. Antidote (external): Flush with water. Antidote (eyes): flush with water for 15 minutes and seek medical attention immediately. Antidote (internal): Drink large quantities of water or milk. Do not induce vomiting. Seek medical attention immediately.

Failure to comply could result in death or serious injury.

W0111A

Special tools

The special tools that CASE IH suggests and illustrate in this manual have been specifically researched and designed for use with CASE IH machines. The special tools are essential for reliable repair operations. The special tools are accurately built and rigorously tested to offer efficient and long-lasting operation.

By using these tools, repair personnel will benefit from:

- Operating in optimal technical conditions
- Obtaining the best results
- Saving time and effort
- Working in safe conditions

Torque - Minimum tightening torques for normal assembly

Decimal hardware

Grade 5 bolts, nuts and studs

Size	Nm	lb in/lb ft
1/4 in	12 - 15 Nm	108 - 132 lb in
5/16 in	23 - 28 Nm	204 - 252 lb in
3/8 in	48 - 57 Nm	420 - 504 lb in
7/16 in	73 - 87 Nm	54 - 64 lb ft
1/2 in	109 - 130 Nm	80 - 96 lb ft
9/16 in	149 - 179 Nm	110 - 132 lb ft
5/8 in	203 - 244 Nm	150 - 180 lb ft
3/4 in	366 - 439 Nm	270 - 324 lb ft
7/8 in	542 - 651 Nm	400 - 480 lb ft
1 in	787 - 944 Nm	580 - 696 lb ft
1-1/8 in	1085 - 1193 Nm	800 - 880 lb ft
1-1/4 in	1519 - 1681 Nm	1120 - 1240 lb ft
1-3/8 in	1980 - 2278 Nm	1460 - 1680 lb ft
1-1/2 in	2631 - 2983 Nm	1940 - 2200 lb ft

Grade 8 bolts, nuts and studs

Size	Nm	lb in/lb ft
1/4 in	16 - 20 Nm	144 - 180 lb in
5/16 in	33 - 39 Nm	288 - 348 lb in
3/8 in	61 - 73 Nm	540 - 648 lb in
7/16 in	95 - 114 Nm	70 - 84 lb ft
1/2 in	149 - 179 Nm	110 - 132 lb ft
9/16 in	217 - 260 Nm	160 - 192 lb ft
5/8 in	298 - 358 Nm	220 - 264 lb ft
3/4 in	515 - 618 Nm	380 - 456 lb ft
7/8 in	814 - 976 Nm	600 - 720 lb ft
1 in	1220 - 1465 Nm	900 - 1080 lb ft
1-1/8 in	1736 - 1953 Nm	1280 - 1440 lb ft
1-1/4 in	2468 - 2712 Nm	1820 - 2000 lb ft
1-3/8 in	3227 - 3688 Nm	2380 - 2720 lb ft
1-1/2 in	4285 - 4827 Nm	3160 - 3560 lb ft

NOTE: Use thick nuts with Grade 8 bolts.

Metric hardware

Grade 8.8 bolts, nuts and studs

Size	Nm	lb in/lb ft
4 mm	3 - 4 Nm	24 - 36 lb in
5 mm	7 - 8 Nm	60 - 72 lb in
6 mm	11 - 12 Nm	96 - 108 lb in
8 mm	26 - 31 Nm	228 - 276 lb in
10 mm	52 - 61 Nm	456 - 540 lb in
12 mm	90 - 107 Nm	66 - 79 lb ft
14 mm	144 - 172 Nm	106 - 127 lb ft
16 mm	217 - 271 Nm	160 - 200 lb ft
20 mm	434 - 515 Nm	320 - 380 lb ft
24 mm	675 - 815 Nm	500 - 600 lb ft
30 mm	1250 - 1500 Nm	920 - 1100 lb ft
36 mm	2175 - 2600 Nm	1600 - 1950 lb ft

INTRODUCTION

Grade 10.9 bolts, nuts and studs

Size	Nm	lb in/lb ft
4 mm	4 - 5 Nm	36 - 48 lb in
5 mm	9 - 11 Nm	84 - 96 lb in
6 mm	15 - 18 Nm	132 - 156 lb in
8 mm	37 - 43 Nm	324 - 384 lb in
10 mm	73 - 87 Nm	54 - 64 lb ft
12 mm	125 - 150 Nm	93 - 112 lb ft
14 mm	200 - 245 Nm	149 - 179 lb ft
16 mm	310 - 380 Nm	230 - 280 lb ft
20 mm	610 - 730 Nm	450 - 540 lb ft
24 mm	1050 - 1275 Nm	780 - 940 lb ft
30 mm	2000 - 2400 Nm	1470 - 1770 lb ft
36 mm	3500 - 4200 Nm	2580 - 3090 lb ft

Grade 12.9 bolts, nuts and studs

Size	Nm	lb in/lb ft
Typically the torque values specified for grade 10.9 hardware can be used satisfactorily on grade 12.9 hardware.		

Steel hydraulic fittings

37° flare fitting

Tube outside diameter/Hose inside diameter		Thread size	Nm	lb in/lb ft
mm	inch			
6.4 mm	1/4 in	7/16-20 in	8 - 16 Nm	72 - 144 lb in
7.9 mm	5/16 in	1/2-20 in	11 - 22 Nm	96 - 192 lb in
9.5 mm	3/8 in	9/16-18 in	14 - 34 Nm	120 - 300 lb in
12.7 mm	1/2 in	3/4-16 in	20 - 57 Nm	180 - 504 lb in
15.9 mm	5/6 in	7/8-14 in	34 - 79 Nm	300 - 696 lb in
19.0 mm	3/4 in	1-1/16-12 in	54 - 108 Nm	40 - 80 lb ft
22.2 mm	7/8 in	1-3/16-12 in	81 - 135 Nm	60 - 100 lb ft
25.4 mm	1 in	1-5/16-12 in	102 - 158 Nm	75 - 117 lb ft
31.8 mm	1-1/4 in	1-5/8-12 in	169 - 223 Nm	125 - 165 lb ft
38.1 mm	1-1/2 in	1-7/8-12 in	285 - 338 Nm	210 - 250 lb ft

Straight threads with O-ring

Tube outside diameter/Hose inside diameter		Thread size	Nm	lb in/lb ft
mm	inch			
6.4 mm	1/4 in	7/16-20 in	16 - 26 Nm	144 - 228 lb in
7.9 mm	5/16 in	1/2-20 in	22 - 34 Nm	192 - 300 lb in
9.5 mm	3/8 in	9/16-18 in	34 - 54 Nm	300 - 480 lb in
12.7 mm	1/2 in	3/4-16 in	57 - 91 Nm	540 - 804 lb in
15.9 mm	5/6 in	7/8-14 in	79 - 124 Nm	58 - 92 lb ft
19.0 mm	3/4 in	1-1/16-12 in	108 - 174 Nm	80 - 128 lb ft
22.2 mm	7/8 in	1-3/16-12 in	136 - 216 Nm	100 - 160 lb ft
25.4 mm	1 in	1-5/16-12 in	159 - 253 Nm	117 - 187 lb ft
31.8 mm	1-1/4 in	1-5/8-12 in	224 - 357 Nm	165 - 264 lb ft
38.1 mm	1-1/2 in	1-7/8-12 in	339 - 542 Nm	250 - 400 lb ft

Split flange mounting bolts

Size	Nm	lb in/lb ft
5/16-18 in	20 - 27 Nm	180 - 240 lb in
3/8-16 in	27 - 34 Nm	240 - 300 lb in
7/16-14 in	47 - 61 Nm	420 - 540 lb in
1/2-13 in	74 - 88 Nm	55 - 65 lb ft

INTRODUCTION

Size	Nm	lb in/lb ft
5/8-11 in	190 - 203 Nm	140 - 150 lb ft

Nominal SAE dash size	O-ring face seal end		Thread size	Nm	lb in/lb ft	O-ring boss end fitting or lock nut		
	Tube outside diameter mm	in				Thread size	Nm	lb in/lb ft
-4	6.4 mm	1/4 in	9/16-18 in	14 - 16 Nm	120 - 144 lb in	7/16-20 in	23 - 27 Nm	204 - 240 lb in
-6	9.5 mm	3/8 in	11/16-16 in	24 - 27 Nm	216 - 240 lb in	9/16-18 in	34 - 41 Nm	300 - 360 lb in
-8	12.7 mm	1/2 in	13/16-16 in	43 - 54 Nm	384 - 480 lb in	3/4-16 in	61 - 68 Nm	540 - 600 lb in
-10	15.9 mm	5/8 in	1-14 in	62 - 76 Nm	552 - 672 lb in	7/8-14 in	81 - 88 Nm	60 - 65 lb ft
-12	19.0 mm	3/4 in	1-3/16-12 in	90 - 110 Nm	65 - 80 lb ft	1-1/16-12 in	115 - 122 Nm	85 - 90 lb ft
-14	22.2 mm	7/8 in	1-3/16-12 in	90 - 110 Nm	65 - 80 lb ft	1-13/16-12 in	129 - 136 Nm	95 - 100 lb ft
-16	25.41 mm	1.0 in	1-7/16-12 in	125 - 140 Nm	92 - 105 lb ft	1-5/16-12 in	156 - 169 Nm	115 - 125 lb ft
-20	31.8 mm	1-1/4 in	1-11/16-12 in	170 - 190 Nm	125 - 140 lb ft	1-5/6-12 in	201 - 217 Nm	150 - 160 lb ft
-24	38.1 mm	1-1/2 in	2-12 in	200 - 254 Nm	150 - 180 lb ft	1-7/8-12 in	258 - 271 Nm	190 - 200 lb ft

Torque - Standard torque data for hydraulics

Installation of adjustable fittings in straight thread O-ring bosses

1. Lubricate the O-ring by coating it with a light oil or petroleum. Install the O-ring in the groove adjacent to the metal backup washer which is assembled at the extreme end of the groove (4).
2. Install the fitting into the SAE straight thread boss until the metal backup washer contacts the face of the boss (5).

NOTE: Do not over tighten and distort the metal backup washer.

3. Position the fitting by turning out (counterclockwise) up to a maximum of one turn. Holding the pad of the fitting with a wrench, tighten the locknut and washer against the face of the boss (6).

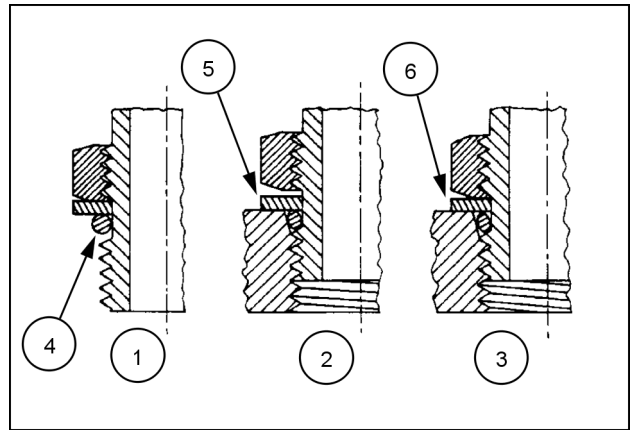

23085659 1

Standard torque data for hydraulic tubes and fittings

Tube nuts for 37° flared fittings				O-ring boss plugs adjustable fitting locknuts, swivel JIC-37° seats
Size	Tubing OD	Thread size	Torque	Torque
4	6.4 mm (1/4 in)	7/16-20	12 - 16 N·m (9 - 12 lb ft)	8 - 14 N·m (6 - 10 lb ft)
5	7.9 mm (5/16 in)	1/2-20	16 - 20 N·m (12 - 15 lb ft)	14 - 20 N·m (10 - 15 lb ft)
6	9.5 mm (3/8 in)	9/16-18	29 - 33 N·m (21 - 24 lb ft)	20 - 27 N·m (15 - 20 lb ft)
8	12.7 mm (1/2 in)	3/4-16	47 - 54 N·m (35 - 40 lb ft)	34 - 41 N·m (25 - 30 lb ft)
10	15.9 mm (5/8 in)	7/8-14	72 - 79 N·m (53 - 58 lb ft)	47 - 54 N·m (35 - 40 lb ft)
12	19.1 mm (3/4 in)	1-1/16-12	104 - 111 N·m (77 - 82 lb ft)	81 - 95 N·m (60 - 70 lb ft)
14	22.2 mm (7/8 in)	1-3/16-12	122 - 136 N·m (90 - 100 lb ft)	95 - 109 N·m (70 - 80 lb ft)
16	25.4 mm (1 in)	1-5/16-12	149 - 163 N·m (110 - 120 lb ft)	108 - 122 N·m (80 - 90 lb ft)
20	31.8 mm (1-1/4 in)	1-5/8-12	190 - 204 N·m (140 - 150 lb ft)	129 - 158 N·m (95 - 115 lb ft)
24	38.1 mm (1-1/2 in)	1-7/8-12	217 - 237 N·m (160 - 175 lb ft)	163 - 190 N·m (120 - 140 lb ft)
32	50.8 mm (2 in)	2-1/2-12	305 - 325 N·m (225 - 240 lb ft)	339 - 407 N·m (250 - 300 lb ft)

These torques are not recommended for tubes of 12.7 mm (1/2 in) OD and larger with wall thickness of 0.889 mm (0.035 in) or less. The torque is specified for 0.889 mm (0.035 in) wall tubes on each application individually.

Before installing and torquing 37° flared fittings, clean the face of the flare and threads with a clean solvent or Loctite cleaner and apply hydraulic sealant LOCTITE® 569™ to the 37° flare and the threads.

Install fitting and torque to specified torque, loosen fitting and retorquing to specifications.

Pipe thread fitting torque

Before installing and tightening pipe fittings, clean the threads with a clean solvent or Loctite cleaner and apply sealant **LOCTITE® 567™ PST PIPE SEALANT** for all fittings including stainless steel or **LOCTITE® 565™ PST** for most metal fittings. For high filtration/zero contamination systems use **LOCTITE® 545™**.

Thread size	Torque (maximum)
1/8-27	13 N·m (10 lb ft)
1/4-18	16 N·m (12 lb ft)
3/8-18	22 N·m (16 lb ft)
1/2-14	41 N·m (30 lb ft)
3/4-14	54 N·m (40 lb ft)

Installation of ORFS (O-Ring Flat Seal fittings)

When installing ORFS fittings thoroughly clean both flat surfaces of the fittings **(1)** and lubricate the O-ring **(2)** with light oil. Make sure both surfaces are aligned properly. Torque the fitting to specified torque listed throughout the repair manual.

NOTICE: *If the fitting surfaces are not properly cleaned, the O-ring will not seal properly. If the fitting surfaces are not properly aligned, the fittings may be damaged and will not seal properly.*

NOTICE: *Always use genuine factory replacement oils and filters to ensure proper lubrication and filtration of engine and hydraulic system oils.*

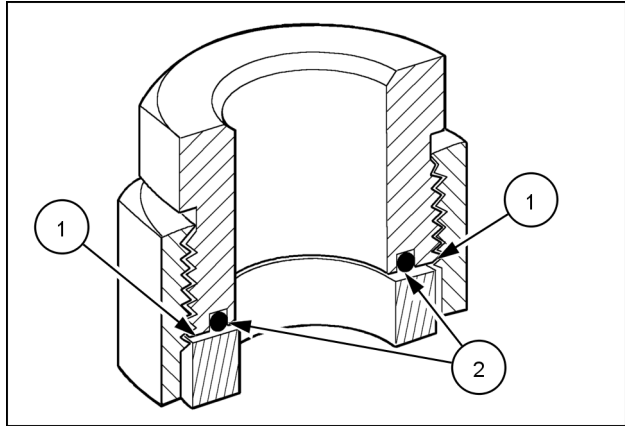

50011183 2

The use of proper oils, grease, and keeping the hydraulic system clean will extend machine and component life.

Maintenance chart

Maintenance action	Test				Grease			
	Check			Change fluid				
	Filling		Drain fluid					
	Cleaning		Calibrate					
	Replace		Adjust					
At warning message display								
Engine air filters	x							
Fuel filters	x							
Every 10 hours or daily								
Machine care	x							
Product tank	x							
Trailing arm pivot area	x							
Fuel tank		x						
Axle adjust stop bolt torque			x					
Engine oil level			x					
Wheel bolt torque			x					
Hydraulic oil level			x					
Engine coolant level			x					
Brake operation (Note 1)				x				
Electrical equipment			x					
Safety equipment			x					
Boom cylinders and joints					x			
Front axle steering knuckle					x			
Gear increaser lubricant			x					
Foam marker (if equipped)	x							
First 50 hours								
Hub lubricant						x		
Hydraulic return & charge pump filters	x							
Battery terminals	x							
Every 50 hours								
Fuel tank and fuel filter						x		
Trailing link suspension pivot					x			
Battery connections			x					
Hub lubricant level			x					
Loose bolts or parts			x					
Tire pressure			x					
Engine coolant mixture level			x					
Radiator and coolers	x							
First 100 hours								
Gear increaser lubricant						x		
Engine oil and filter						x		
Fuel filters	x							
Engine air filters	x							
Every 250 hours								
Hydraulic hoses and electrical wiring			x					
Hydraulic return & charge pump filters	x							
Engine air intake hoses			x					
Every 450 hours or once a year								
Cab air filter	x							
Cab internal foam filter		x						
Cab air recirculation filter	x							
Every 500 hours								
Gear increaser lubricant						x		
Hub lubricant						x		

INTRODUCTION

Maintenance action	Test				Grease			
	Check			Change fluid				
	Filling		Drain fluid					
	Cleaning	Calibrate						
	Replace	Adjust						
Hydraulic system breather (Note 2)	x							
Spray system						x		
Fuel filters	x							
Every 600 hours								
Engine oil and filter						x		
Every 1000 hours								
Engine air filters	x							
Hydraulic tank fluid and filters						x		
Every 1800 hours								
Engine crankcase breather filter	x							
Every 4000 hours or every four years								
Engine coolant						x		
As required maintenance								
Cab		x						
Cooling system thermostat			x					
Boom strainers (Note 3)		x						
Flow meter							x	
Flow meter sensor	x							
Battery fluid level			x					
Steering cylinder toe in			x					
Battery maintenance			x					
Engine drive belts	x							

Hydraulic contamination

Contamination in the hydraulic system is a major cause of the malfunction of hydraulic components. Contamination is any foreign material in the hydraulic oil.

Contamination can enter the hydraulic system in several ways:

- When you drain the oil or disconnect any line
- When you disassemble a component
- From normal wear of the hydraulic components
- From damaged seals or worn seals
- From a damaged component in the hydraulic system

All hydraulic systems operate with some contamination. The design of the components in this hydraulic system permits efficient operation with a small amount of contamination. An increase in this amount of contamination can cause problems in the hydraulic system.

The following list includes some of these problems:

- Cylinder rod seals that leak
- Control valve spools that do not return to neutral
- Movement of control valve spools is difficult
- Hydraulic oil that becomes too hot
- Pump gears, housing, and other parts that wear rapidly
- Relief valves or check valves held open by dirt
- Quick failure of components that have been repaired
- Slow cycle times are slow. The machine does not have enough power.

If your machine has any of these problems, check the hydraulic oil for contamination.

There are two types of contamination: microscopic and visible.

Microscopic contamination occurs when very fine particles of foreign material are suspended in the hydraulic oil. These particles are too small to see or feel. Microscopic contamination can be found by identification of the following problems or by testing in a laboratory.

Examples of problems caused by microscopic contamination:

- Cylinder rod seals that leak
- Control valve spools that do not return to neutral
- The hydraulic system has a high operating temperature

Visible contamination is foreign material that can be found by sight, touch, or odor. Visible contamination can cause a sudden failure of components.

Examples of problems caused by visible contamination:

- Particles of metal or dirt in the oil
- Air in the oil
- Dark or thick oil
- Oil with an odor of burned oil
- Water in the oil

If you find contamination, use a portable filter to clean the hydraulic system.

Capacities

Engine	
Oil type	CASE IH AKCELA UNITEK NO. 1™ SBL CJ-4
Oil exchange capacity with filter (approximate.)	16 L (4.2 US gal)
Cooling system	
Coolant type	CASE IH AKCELA ACTIFULL™ OT EXTENDED LIFE COOLANT
System coolant capacity	51 L (13.5 US gal)
Hydraulic system	
Oil type	CASE IH AKCELA HY-TRAN® ULTRACTION
Tank capacity	110 L (29 US gal)
Hub lubricant	
Oil type	CASE IH AKCELA GEAR 135 H EP 85W-140
Hub capacity (each)	0.87 L (1.84 US pt)
Gear increaser	
Oil type	CASE IH AKCELA GEAR LUBE SSL 75W90
Capacity	1.9 L (4 US pt)
Air conditioning system	
Refrigerant type	R134A
Refrigerant capacity	1.65 kg (3.63 lb)

General specification

Item	Specification	
Engine	131 kW (175 Hp), 6.7 l (409 in³) Case IH FPT turbocharged, after-cooled, electronic controlled diesel engine. Emission level (tier) 3	
Drive	Hydrostatic with full-time 4-wheel drive. 4 speed ranges, can be shifted on-the-go.	
Wheel Adjustment	229 - 305 cm (90 - 120 in) mechanically adjusted with manual stops or hydraulically adjusted (optional) from the cab with manual stops at 5.1 cm (2 in) increments per wheel.	
Suspension	Spring and shock absorber trailing arm suspension that acts independently at each wheel standard. Active suspension optional.	
Steering	Hydraulic power steering with master/slave re-phasing cylinders.	
Cab	Summer/winter climate control and activated charcoal fresh air filter	
	Air seat with lumbar, ride firmness, fore/aft position, height, side to side and fore/aft shock isolation adjustment.	
	Single speed front windshield wiper/washer.	
	Wired for radio includes antenna, 2 speakers.	
	Tilt steering column with soft grip automotive type steering wheel	
Brakes	Full instrumentation	
	Dynamic dry disc service brakes on the front wheels with brake pedal in the cab. Hydraulic wet disc type all wheel parking brakes.	
Travel speed	Up to 45 km/h (28 mph) .	
Fuel tank	454 L (120 US gal)	
Dimensions	Dry weight	9385 kg (20690 lb) (27 m (90 ft) boom)
	Overall length	8.8 m (346 in)
	Overall width	3.2 m (126 in) (retracted)
		3.5 m (138 in) (extended)
	Overall height	3.72 m (146 in)
	Wheel base	3.6 m (140 in)
	Ground clearance	158 cm (62 in) with R42 tires 148 cm (58 in) with R42 tires and chemical eductor
Tire sizes	380/80R38	
	IF380/80R38	
	IF320/90R42	
	IF420/85R38	
Turning Radius	6.9 m (22.6 ft) from centerline of rear axle	
Boom	Boom length	24.4 m (80 ft)
		27.4 m (90 ft)
	Boom tip breakaway	24.4 m (80 ft) / 27.4 m (90 ft) boom — 1.6 m (62.5 in)
Product System	Hydraulically driven centrifugal liquid pump with Pulse Width Modulation (PWM) electronic control	
	50.8 mm (2 in) fill system or 76.2 mm (3 in) fill system (as ordered)	
	Sparge is provided by jet nozzles.	
	Product strainer - 16 mesh	
	Boom strainers - 50 mesh	
Product tank	2498 l (660 US gal)	
Rinse tank	280 l (74 US gal)	
Chemical eductor	Optional	
Paint	Long lasting, durable polyurethane.	

Product identification

Sprayer model and product identification number

Write your model number, product identification number (PIN) or serial number of major components on the lines provided. If needed, give these numbers to your dealer when you need parts or information for your machine.

CNH Industrial America LLC		CASE III AGRICULTURE	
Type	Designation		
Version	Type approval		
Product ID Number (PIN)			
Permissible laden mass:		kg	kg
Permissible load Axle 1		max	
Permissible load Axle 2		kg	
Permissible load Axle 3		kg	
Liquid System Working Pressure		kg	
Nominal Tank Volume		kPa	
		L	
Made in:		U.S.A.	
Unladen mass		kg	Number of rows
Rated net power		kw	length
		(ECE R120)	m
			width
			m
			Height
			m
Model Year			
Year of Construction			
L2006/2010 EC 1.7.3		47804360 A	

47804360A 1

Model :

PIN:

NOTE: Located on the front of the boom support on the right front side of the machine.

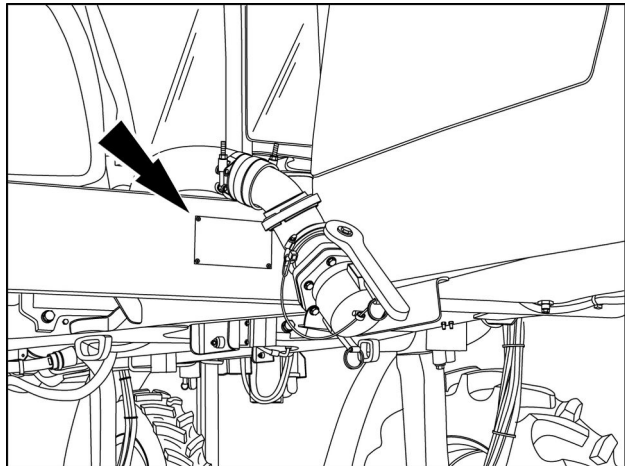

RAIL14SP01802AA 2

Engine serial number

Serial number:

NOTE: Located on rocker arm cover toward front side of the engine.

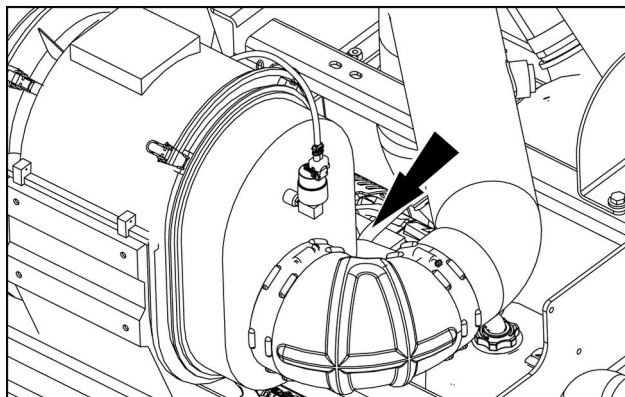

RAIL15SP00388AA 3

Product identification - Machine orientation

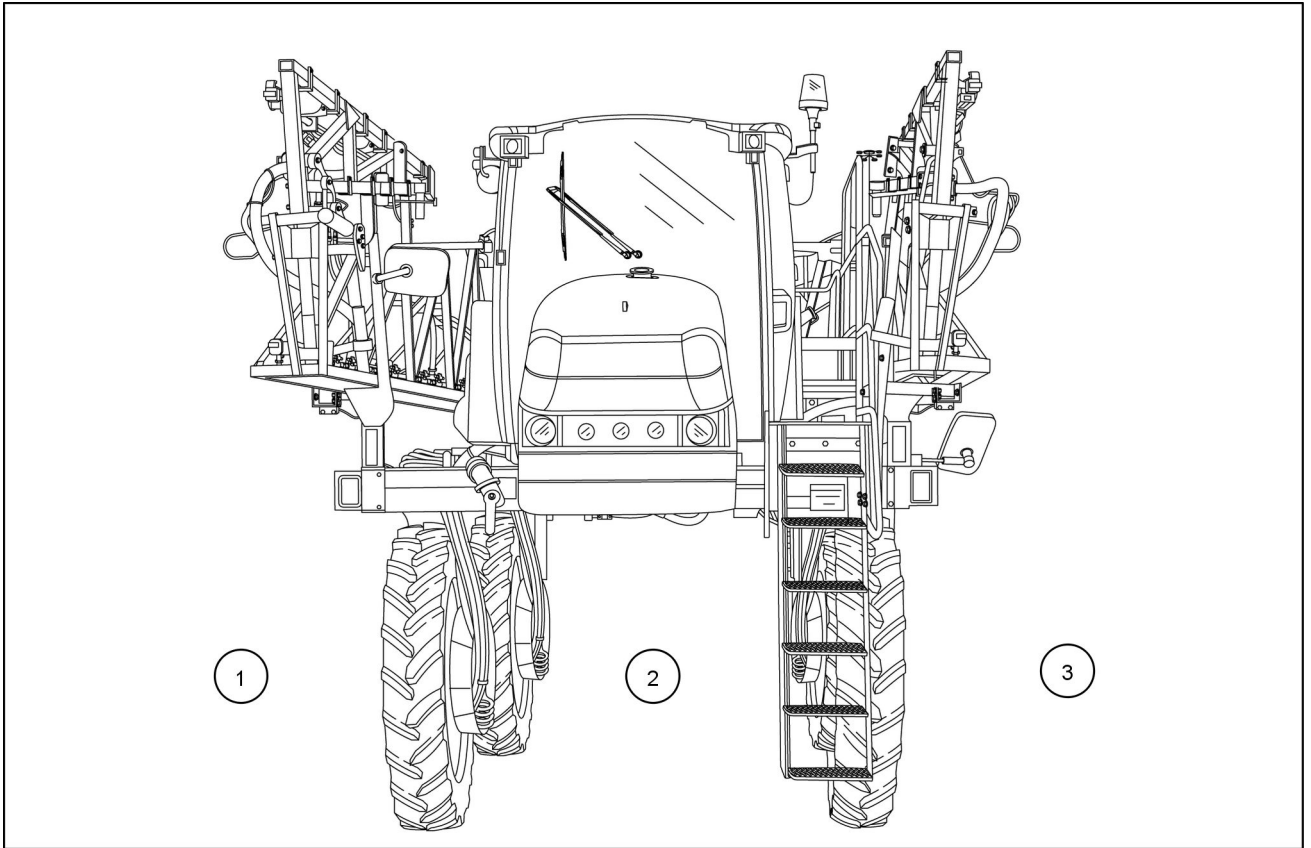

RAIL14SP01779FA 1

1. Right hand side	2. Front of unit	3. Left hand side
--------------------	------------------	-------------------

Thank you so much for reading.
Please click the “Buy Now!”
button below to download the
complete manual.



After you pay.

You can download the most
perfect and complete manual in
the world immediately.

Our support email:

ebooklibonline@outlook.com