

A8810 DA
Sugar cane harvester

SERVICE MANUAL

Part number 48114624

English

May 2018

© 2018 CNH industrial Latin America LTDA. All Rights Reserved.





SERVICE MANUAL

8810 FPT engine, TIER 3 - DA [PRCY8800JHPA03535- -]

Link Product / Engine

Product	Market Product	Engine
8810 FPT engine, TIER 3 - DA [PRCY8800JHPA03535- -]	Latin America	F2CFP613C*H003

Contents

INTRODUCTION

Engine	10
[10.001] Engine and crankcase	10.1
[10.216] Fuel tanks	10.2
[10.206] Fuel filters	10.3
[10.202] Air cleaners and lines	10.4
[10.400] Engine cooling system	10.5
[10.414] Fan and drive	10.6
[10.310] Aftercooler.....	10.7
[10.304] Engine lubrication system.....	10.8
Power coupling	19
[19.121] Pump-drive assembly	19.1
Rear axle system	27
[27.120] Planetary and final drives	27.1
Hydrostatic drive	29
[29.100] Transmission and steering hydrostatic control	29.1
[29.218] Pump and motor components.....	29.2
Hydraulic systems	35
[35.000] Hydraulic systems.....	35.1
[35.300] Reservoir, cooler, and filters.....	35.2
[35.104] Fixed displacement pump.....	35.3
[35.752] Hydraulic fan drive cooling system.....	35.4
[35.965] Chopper control system.....	35.5
[35.370] Tracks suspension hydraulic system.....	35.6
[35.670] Topper hydraulic system	35.7
[35.672] Crop divider hydraulic system.....	35.8

[35.674] Base cutter hydraulic system	35.9
[35.676] Knock-down rollers hydraulic system	35.10
[35.678] Butt lifter roller hydraulic system	35.11
[35.680] Finned roller hydraulic system	35.12
[35.682] Billet elevator hydraulic system	35.13
Tracks and track suspension	48
[48.130] Track frame and driving wheels	48.1
[48.100] Tracks	48.2
[48.134] Track tension units	48.3
Cab climate control	50
[50.100] Heating	50.1
[50.200] Air conditioning	50.2
Electrical systems	55
[55.100] Harnesses and connectors	55.1
[55.301] Alternator	55.2
[55.302] Battery	55.3
[55.518] Wiper and washer system	55.4
[55.404] External lighting	55.5
[55.514] Cab lighting	55.6
[55.DTC] FAULT CODES	55.7
Attachments/Headers	58
[58.130] Attachment/Header frame	58.1
Product feeding	60
[60.370] Basecutter	60.1
[60.390] Conveyor roller train	60.2
Chopping	64
[64.130] Drum gearbox	64.1

[64.160] Crop processor	64.2
Cleaning	74
[74.204] Lower extractors	74.1
Crop storage / Unloading	80
[80.420] Billet elevator	80.1
Platform, cab, bodywork, and decals	90
[90.150] Cab	90.1
[90.151] Cab interior	90.2



INTRODUCTION

Contents

INTRODUCTION

Security lock, transport and service - Side safety locks	3
Topper hydraulic cylinder - Safety rules - Topper safety lock	4
Safety rules - Engine access - Grips inside the engine compartment	5
Personal safety - Safety anchor points	6
Torque - Minimum tightening torques for normal assembly	8
Torque - Standard torque data for hydraulic connections	13
Consumables	20

Security lock, transport and service - Side safety locks

When you perform any maintenance procedures on the harvester, it is mandatory that you use the safety locks (1).

1. With the machine parked on a level and firm surface, use the hydraulic suspension control to suspend the machine at the desired height.
2. Hold the lock (1) with one hand. Then remove the cotter pins (2) and the pins (3).

NOTICE: The locks (1) are quite heavy. Be careful not to accidentally drop the locks when you remove the pins (3).

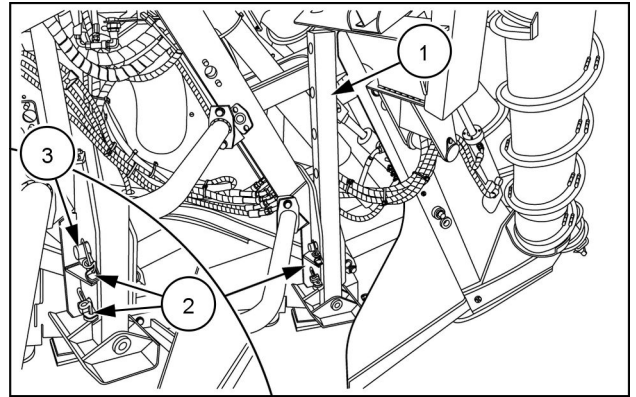

SOIL17SC00352AA 1

3. Lower the locks (1) to the ground.
4. Install the pins (2) and the cotter pins (3).

NOTE: On ground that is wet and/or not compacted, the locks (1) may sink and cause the harvester to lower. Look for a proper location to safely support the locks.

NOTICE: Before you go under the harvester, always make sure that the pins (2) are properly installed in the holes of the locks (1).

NOTE: Before you operate the harvester, always check that the locks (1) are properly retracted and locked, as shown in figure 1.

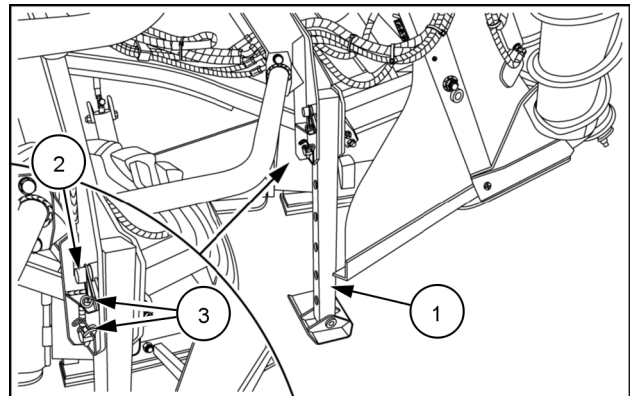

SOIL17SC00351AA 2

5. Use the hydraulic suspension control to fully lower the machine.

Topper hydraulic cylinder - Safety rules - Topper safety lock

When you perform any maintenance procedures on the harvester, and more specifically on the line dividers and the front rollers, it is essential that you use the safety lock (1) on the topper if you need to raise the topper to perform the procedure.

1. With the machine parked on a level and firm surface, completely suspend the topper.
2. Pull the handle (2) all the way to unseat the lock pin (3) from the rear hole of the cradle (4).
3. Fit the lock (1) over the lift cylinder rod (5). See Figure 2.

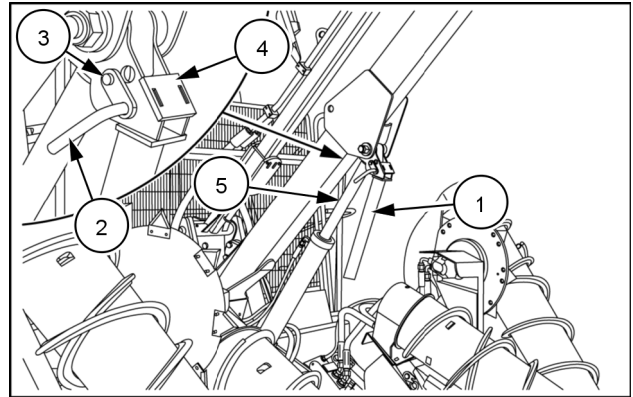

SOIL17SC00778AA 1

4. With the latch (1) in the position shown, turn the handle (2) slightly upward and release the handle to seat the lock pin (3) in the front hole of the cradle (4).

NOTICE: Before you go underneath the suspended topper, always check that the lock (1) is properly positioned and secured.

5. To lower the topper, secure the lock (1) in the operating position, as shown in figure 1.

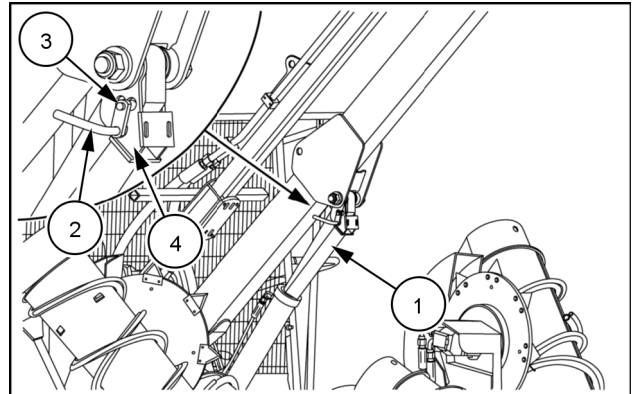

SOIL17SC00779AA 2

Safety rules - Engine access - Grips inside the engine compartment

The harvester is equipped with four grips (1) in the engine compartment, two on each side, as specified below.

Whenever you perform a procedure inside the engine compartment, try to support yourself by holding on the grips (1).

ATTENTION: To prevent the risk of burns, cuts, or accidental disconnections, do not hold onto the hydraulic hoses or other components of the assembly. To do so may result in accidents with minor or moderate injury.

- Figure 1 – Engine compartment on the right-hand side of the machine.
- Figure 2 – Pumps compartment on the left-hand side of the machine.

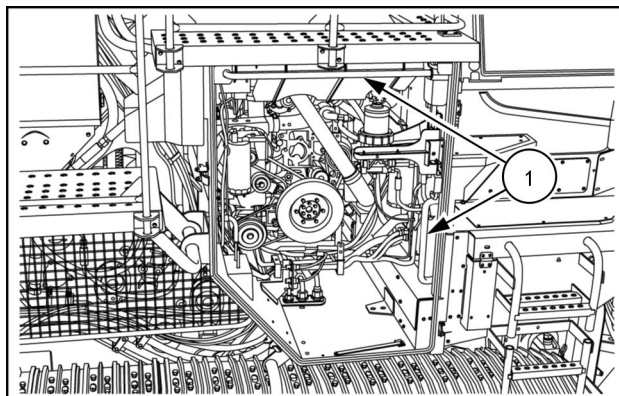

SOIL17SC00744AA 1

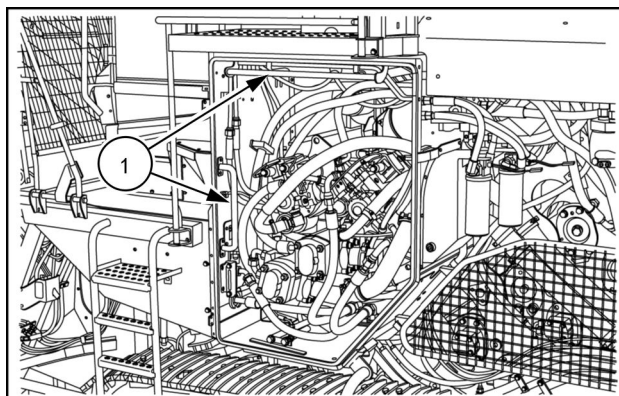

SOIL17SC00745AA 2

Personal safety - Safety anchor points

⚠ WARNING

Fall hazard!

Clean the steps and access handles to remove all traces of grease, oil, mud, and ice (in winter).
Failure to comply could result in death or serious injury.

W0139A

⚠ WARNING

Fall hazard!

Take correct measures to make sure steps, ladders, and platforms remain clean and clear of debris or foreign substances.
Failure to comply could result in death or serious injury.

W1183A

ATTENTION: Before you perform any maintenance work on the highest parts of the harvester, such as the cab and the primary hood extractor, check and familiarize yourself with the following safety anchor points, to which you can attach safety straps when you get on and off of the machine.

The harvester is equipped with various safety anchor points, which should be used when you perform adjustments or maintenance on the highest parts of the machine, in order to prevent falls and personal injury.

Identification, location, and function of the available anchor points:

- Front hood grab handle (1): This can be used as grip or to secure cables or straps with a hook, for work at the top of the cab, such as changing bulbs.
- Eye bolts on the side shields (2): For the attachment of cables or straps with a hook.

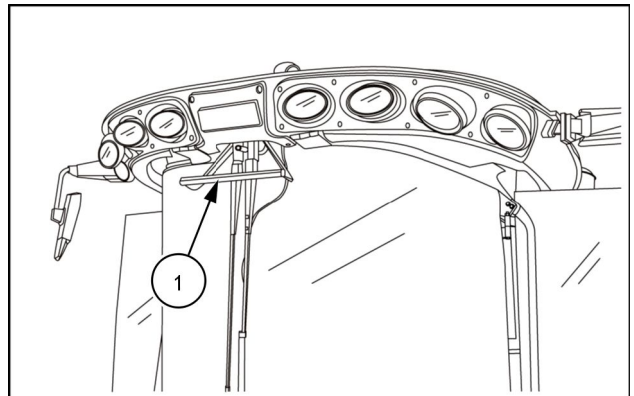

SOIL17SC00313AA 1

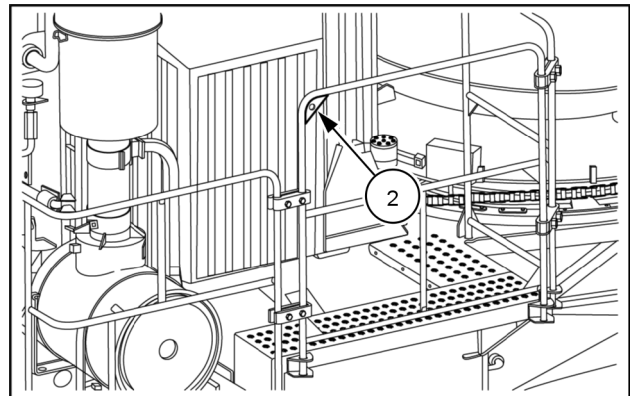

SOIL17SC00802AA 2

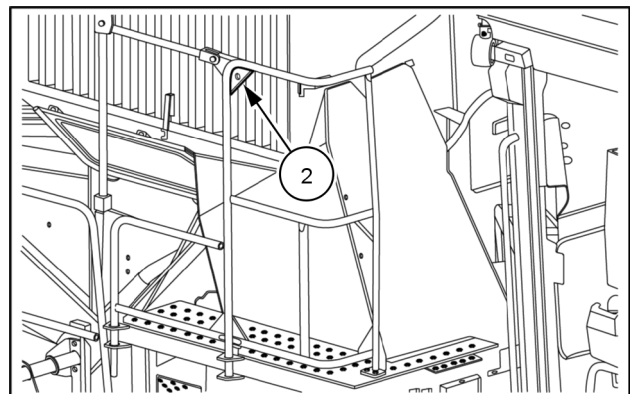

SOIL17SC00803AA 3

- Handles on the hood frame (3): For the attachment of cables or straps with a hook, for work at the top of the hood, such as checking the extractor hydraulic drive motor.

NOTE: Laws that govern work at heights vary by country, so seek the necessary guidance from regulatory agencies. If there is a specific regulation at the state level, or even at the municipal level, follow this regulation the same way.

NOTE: The owner of the machine is responsible for providing operators and mechanics with the necessary safety guidelines on work at heights, through execution of a training program.

NOTE: The owner must provide operators and mechanics with all necessary PPE, as required by the regulations in effect, such as: seat belt, cables, straps, life line, helmets, etc. It is also the owner's responsibility to supervise the correct use of these safety features.

NOTE: Operators and mechanics are responsible for correctly using the proper PPEs, in accordance with the guidelines of the regulations in effect.

ATTENTION: Only use safety devices in perfect working condition, free of damage.

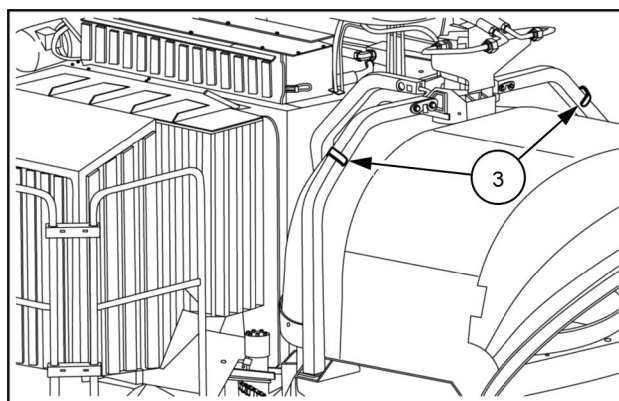

SOIL17SC00804AA 4

Torque - Minimum tightening torques for normal assembly

METRIC NON-FLANGED HARDWARE

NOM. SIZE	CLASS 8.8 BOLT and CLASS 8 NUT		CLASS 10.9 BOLT and CLASS 10 NUT		LOCKNUT CL.8 W/CL8.8 BOLT	LOCKNUT CL.10 W/CL10.9 BOLT
	UNPLATED	PLATED W/ZnCr	UNPLATED	PLATED W/ZnCr		
M4	2.2 N·m (19 lb in)	2.9 N·m (26 lb in)	3.2 N·m (28 lb in)	4.2 N·m (37 lb in)	2 N·m (18 lb in)	2.9 N·m (26 lb in)
M5	4.5 N·m (40 lb in)	5.9 N·m (52 lb in)	6.4 N·m (57 lb in)	8.5 N·m (75 lb in)	4 N·m (36 lb in)	5.8 N·m (51 lb in)
M6	7.5 N·m (66 lb in)	10 N·m (89 lb in)	11 N·m (96 lb in)	15 N·m (128 lb in)	6.8 N·m (60 lb in)	10 N·m (89 lb in)
M8	18 N·m (163 lb in)	25 N·m (217 lb in)	26 N·m (234 lb in)	35 N·m (311 lb in)	17 N·m (151 lb in)	24 N·m (212 lb in)
M10	37 N·m (27 lb ft)	49 N·m (36 lb ft)	52 N·m (38 lb ft)	70 N·m (51 lb ft)	33 N·m (25 lb ft)	48 N·m (35 lb ft)
M12	64 N·m (47 lb ft)	85 N·m (63 lb ft)	91 N·m (67 lb ft)	121 N·m (90 lb ft)	58 N·m (43 lb ft)	83 N·m (61 lb ft)
M16	158 N·m (116 lb ft)	210 N·m (155 lb ft)	225 N·m (166 lb ft)	301 N·m (222 lb ft)	143 N·m (106 lb ft)	205 N·m (151 lb ft)
M20	319 N·m (235 lb ft)	425 N·m (313 lb ft)	440 N·m (325 lb ft)	587 N·m (433 lb ft)	290 N·m (214 lb ft)	400 N·m (295 lb ft)
M24	551 N·m (410 lb ft)	735 N·m (500 lb ft)	762 N·m (560 lb ft)	1016 N·m (750 lb ft)	501 N·m (370 lb ft)	693 N·m (510 lb ft)

NOTE: M4 through M8 hardware torque specifications are shown in pound-inches. M10 through M24 hardware torque specifications are shown in pound-feet.

METRIC FLANGED HARDWARE

NOM. SIZE	CLASS 8.8 BOLT and CLASS 8 NUT		CLASS 10.9 BOLT and CLASS 10 NUT		LOCKNUT CL.8 W/CL8.8 BOLT	LOCKNUT CL.10 W/CL10.9 BOLT
	UNPLATED	PLATED W/ZnCr	UNPLATED	PLATED W/ZnCr		
M4	2.4 N·m (21 lb in)	3.2 N·m (28 lb in)	3.5 N·m (31 lb in)	4.6 N·m (41 lb in)	2.2 N·m (19 lb in)	3.1 N·m (27 lb in)
M5	4.9 N·m (43 lb in)	6.5 N·m (58 lb in)	7.0 N·m (62 lb in)	9.4 N·m (83 lb in)	4.4 N·m (39 lb in)	6.4 N·m (57 lb in)
M6	8.3 N·m (73 lb in)	11 N·m (96 lb in)	12 N·m (105 lb in)	16 N·m (141 lb in)	7.5 N·m (66 lb in)	11 N·m (96 lb in)
M8	20 N·m (179 lb in)	27 N·m (240 lb in)	29 N·m (257 lb in)	39 N·m (343 lb in)	18 N·m (163 lb in)	27 N·m (240 lb in)
M10	40 N·m (30 lb ft)	54 N·m (40 lb ft)	57 N·m (42 lb ft)	77 N·m (56 lb ft)	37 N·m (27 lb ft)	53 N·m (39 lb ft)
M12	70 N·m (52 lb ft)	93 N·m (69 lb ft)	100 N·m (74 lb ft)	134 N·m (98 lb ft)	63 N·m (47 lb ft)	91 N·m (67 lb ft)
M16	174 N·m (128 lb ft)	231 N·m (171 lb ft)	248 N·m (183 lb ft)	331 N·m (244 lb ft)	158 N·m (116 lb ft)	226 N·m (167 lb ft)
M20	350 N·m (259 lb ft)	467 N·m (345 lb ft)	484 N·m (357 lb ft)	645 N·m (476 lb ft)	318 N·m (235 lb ft)	440 N·m (325 lb ft)
M24	607 N·m (447 lb ft)	809 N·m (597 lb ft)	838 N·m (618 lb ft)	1118 N·m (824 lb ft)	552 N·m (407 lb ft)	

IDENTIFICATION

Metric Hex head and carriage bolts, classes 5.6 and up

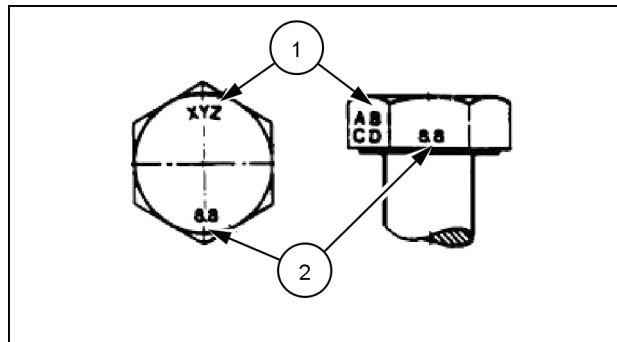

20083680 1

1. Manufacturer's Identification
2. Property Class

Metric Hex nuts and locknuts, classes 05 and up

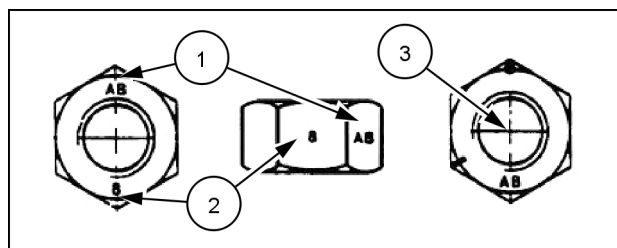

20083681 2

1. Manufacturer's Identification
2. Property Class
3. Clock Marking of Property Class and Manufacturer's Identification (Optional), i.e. marks **60°** apart indicate Class 10 properties, and marks **120°** apart indicate Class 8.

INCH NON-FLANGED HARDWARE

NOMINAL SIZE	SAE GRADE 5 BOLT and NUT		SAE GRADE 8 BOLT and NUT		LOCKNUT GrB W/ Gr5 BOLT	LOCKNUT GrC W/ Gr8 BOLT
	UN-PLATED or PLATED SILVER	PLATED W/ZnCr GOLD	UN-PLATED or PLATED SILVER	PLATED W/ZnCr GOLD		
1/4	8 N·m (71 lb in)	11 N·m (97 lb in)	12 N·m (106 lb in)	16 N·m (142 lb in)	8.5 N·m (75 lb in)	12.2 N·m (109 lb in)
5/16	17 N·m (150 lb in)	23 N·m (204 lb in)	24 N·m (212 lb in)	32 N·m (283 lb in)	17.5 N·m (155 lb in)	25 N·m (220 lb in)
3/8	30 N·m (22 lb ft)	40 N·m (30 lb ft)	43 N·m (31 lb ft)	57 N·m (42 lb ft)	31 N·m (23 lb ft)	44 N·m (33 lb ft)
7/16	48 N·m (36 lb ft)	65 N·m (48 lb ft)	68 N·m (50 lb ft)	91 N·m (67 lb ft)	50 N·m (37 lb ft)	71 N·m (53 lb ft)
1/2	74 N·m (54 lb ft)	98 N·m (73 lb ft)	104 N·m (77 lb ft)	139 N·m (103 lb ft)	76 N·m (56 lb ft)	108 N·m (80 lb ft)
9/16	107 N·m (79 lb ft)	142 N·m (105 lb ft)	150 N·m (111 lb ft)	201 N·m (148 lb ft)	111 N·m (82 lb ft)	156 N·m (115 lb ft)
5/8	147 N·m (108 lb ft)	196 N·m (145 lb ft)	208 N·m (153 lb ft)	277 N·m (204 lb ft)	153 N·m (113 lb ft)	215 N·m (159 lb ft)
3/4	261 N·m (193 lb ft)	348 N·m (257 lb ft)	369 N·m (272 lb ft)	491 N·m (362 lb ft)	271 N·m (200 lb ft)	383 N·m (282 lb ft)
7/8	420 N·m (310 lb ft)	561 N·m (413 lb ft)	594 N·m (438 lb ft)	791 N·m (584 lb ft)	437 N·m (323 lb ft)	617 N·m (455 lb ft)
1	630 N·m (465 lb ft)	841 N·m (620 lb ft)	890 N·m (656 lb ft)	1187 N·m (875 lb ft)	654 N·m (483 lb ft)	924 N·m (681 lb ft)

NOTE: For Imperial Units, 1/4 in and 5/16 in hardware torque specifications are shown in pound-inches. 3/8 in through 1 in hardware torque specifications are shown in pound-feet.

INCH FLANGED HARDWARE

NOM- INAL SIZE	SAE GRADE 5 BOLT and NUT		SAE GRADE 8 BOLT and NUT		LOCKNUT GrF W/ Gr5 BOLT	LOCKNUT GrG W/ Gr8 BOLT
	UNPLATED or PLATED SILVER	PLATED W/ZnCr GOLD	UNPLATED or PLATED SILVER	PLATED W/ZnCr GOLD		
1/4	9 N·m (80 lb in)	12 N·m (106 lb in)	13 N·m (115 lb in)	17 N·m (150 lb in)	8 N·m (71 lb in)	12 N·m (106 lb in)
5/16	19 N·m (168 lb in)	25 N·m (221 lb in)	26 N·m (230 lb in)	35 N·m (310 lb in)	17 N·m (150 lb in)	24 N·m (212 lb in)
3/8	33 N·m (25 lb ft)	44 N·m (33 lb ft)	47 N·m (35 lb ft)	63 N·m (46 lb ft)	30 N·m (22 lb ft)	43 N·m (32 lb ft)
7/16	53 N·m (39 lb ft)	71 N·m (52 lb ft)	75 N·m (55 lb ft)	100 N·m (74 lb ft)	48 N·m (35 lb ft)	68 N·m (50 lb ft)
1/2	81 N·m (60 lb ft)	108 N·m (80 lb ft)	115 N·m (85 lb ft)	153 N·m (113 lb ft)	74 N·m (55 lb ft)	104 N·m (77 lb ft)
9/16	117 N·m (86 lb ft)	156 N·m (115 lb ft)	165 N·m (122 lb ft)	221 N·m (163 lb ft)	106 N·m (78 lb ft)	157 N·m (116 lb ft)
5/8	162 N·m (119 lb ft)	216 N·m (159 lb ft)	228 N·m (168 lb ft)	304 N·m (225 lb ft)	147 N·m (108 lb ft)	207 N·m (153 lb ft)
3/4	287 N·m (212 lb ft)	383 N·m (282 lb ft)	405 N·m (299 lb ft)	541 N·m (399 lb ft)	261 N·m (193 lb ft)	369 N·m (272 lb ft)
7/8	462 N·m (341 lb ft)	617 N·m (455 lb ft)	653 N·m (482 lb ft)	871 N·m (642 lb ft)	421 N·m (311 lb ft)	594 N·m (438 lb ft)
1	693 N·m (512 lb ft)	925 N·m (682 lb ft)	979 N·m (722 lb ft)	1305 N·m (963 lb ft)	631 N·m (465 lb ft)	890 N·m (656 lb ft)

IDENTIFICATION

Inch Bolts and free-spinning nuts

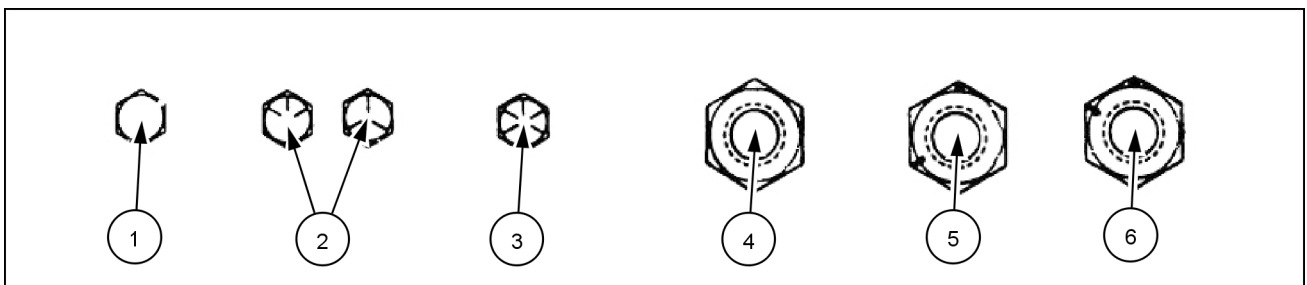

20083682 3

Grade Marking Examples

SAE Grade Identification			
1	Grade 2 - No Marks	4	Grade 2 Nut - No Marks
2	Grade 5 - Three Marks	5	Grade 5 Nut - Marks 120° Apart
3	Grade 8 - Five Marks	6	Grade 8 Nut - Marks 60° Apart

Inch Lock Nuts, All Metal (Three optional methods)

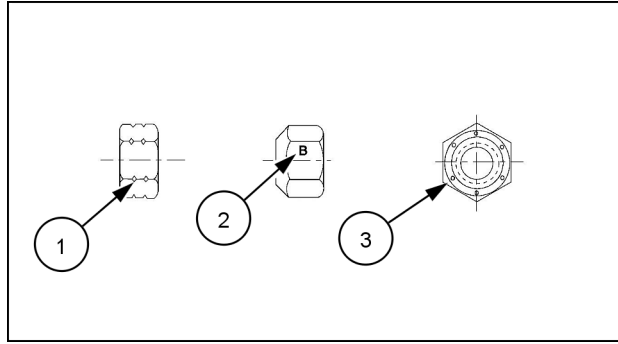

20090268 4

Grade Identification

Grade	Corner Marking Method (1)	Flats Marking Method (2)	Clock Marking Method (3)
Grade A	No Notches	No Mark	No Marks
Grade B	One Circumferential Notch	Letter B	Three Marks
Grade C	Two Circumferential Notches	Letter C	Six Marks

Torque - Standard torque data for hydraulic connections

General information

- Hydraulic connections require a minimum assembly torque in order to provide zero leakage at rated pressure with adequate fatigue resistance. Over-torquing of a hydraulic connection can also lead to leakage or failure. For some connections, CASE IH requires a different torque value than is listed in the ISO and SAE standards.
- The torque values in this document should be used whenever possible or applicable.

NOTICE: Always follow the instructions in this manual for specific torque values when you service components. The information in this section is for general guidance only when a procedure contains no specific torque value.

Tolerance

- The tolerance for all torque values is $\pm 10\%$. This tolerance must include all assembly variation, not only the torque wrench repeatability.

Lubrication

Application of grease or other lubricants to hydraulic connectors should be avoided. If clean hydraulic oil is already on the connection, it is not required to remove the oil. Generally, application of grease:

- May cause a significant change in the torque required to properly tighten the connection.
- May reduce the connection's resistance to vibration.
- Excessive grease may displace an elastomer seal during tightening.
- Grease extrusion when connection is tightened may be mistaken for leakage.

CASE IH products generally use O-Ring Boss (ORB) connectors that have Teflon™-coated O-rings, eliminating the need for O-ring lubrication during installation. For connections which are made into aluminum manifolds or with stainless steel connectors, it may be required to apply a lubricant to prevent galling.

Use of **LOCTITE®** and other thread-locking compounds is prohibited. These compounds:

- May cause a significant change in the torque required to properly tighten the connections.
- Reduce the serviceability of the joint.
- May prevent the O-ring from properly sealing if the compound gets on the O-ring.

INTRODUCTION

Torque values for metric O-Ring Boss (ORB) port connections

Metric thread	S-Series *		L-Series **	
	Ferrous N·m (lb ft) ± 10%	Non-Ferrous N·m (lb ft) ± 10%	Ferrous N·m (lb ft) ± 10%	Non-Ferrous N·m (lb ft) ± 10%
M8 x 1	10.5 (7.7)	6.3 (4.6)	8.5 (6.3)	5 (3.7)
M10 x 1	21 (15.5)	12.5 (9.2)	15.5 (11.4)	9.3 (6.9)
M12 x 1.5	37 (27.3)	22 (16.2)	27 (19.9)	16 (11.8)
M14 x 1.5	47 (34.7)	28 (20.7)	37 (27.3)	22 (16.2)
M16 x 1.5	58 (42.8)	35 (25.8)	42 (31)	25 (18.4)
M18 x 1.5	74 (54.6)	44 (32.5)	47 (34.7)	28 (20.7)
M22 x 1.5	105 (77.4)	63 (46.5)	63 (46.5)	38 (28)
M27 x 2	178 (131.3)	107 (78.9)	105 (77.4)	63 (46.5)
M30 x 2	225 (166)	135 (99.6)	136 (100.3)	82 (60.5)
M33 x 2	325 (239.7)	195 (143.8)	168 (123.9)	101 (74.5)
M42 x 2	345 (254.5)	207 (152.7)	220 (162.3)	132 (97.4)
M48 x 2	440 (324.5)	264 (194.7)	273 (201.4)	164 (121)
M60 x 2	525 (387.2)	315 (232.3)	330 (243.4)	198 (146)

* S-Series connectors are used with O-Ring Face Seals (ORFS).

** L-Series connectors are used with 37° flare.

Torque values for metric O-Ring Boss (ORB) port plugs

Metric thread	Ferrous		Non-ferrous
	Internal hex N·m (lb ft) ± 10%	External hex N·m (lb ft) ± 10%	N·m (lb ft) ± 10%
M8 x 1	8.5 (6.3)	10.5 (7.7)	6.3 (4.6)
M10 x 1	16 (11.8)	21 (15.5)	12.5 (9.2)
M12 x 1.5	23 (17)	37 (27.3)	22 (16.2)
M14 x 1.5	47 (34.7)	47 (34.7)	28 (20.7)
M16 x 1.5	58 (42.8)	58 (42.8)	35 (25.8)
M18 x 1.5	74 (54.6)	74 (54.6)	44 (32.5)
M22 x 1.5	105 (77.4)	105 (77.4)	63 (46.5)
M27 x 2	178 (131.3)	178 (131.3)	107 (78.9)
M30 x 2	225 (166)	225 (166)	135 (99.6)
M33 x 2	325 (239.7)	325 (239.7)	195 (143.8)
M42 x 2	345 (254.5)	345 (254.5)	207 (152.7)
M48 x 2	440 (324.5)	440 (324.5)	264 (194.7)
M60 x 2	525 (387.2)	525 (387.2)	315 (232.3)

Thank you so much for reading.
Please click the “Buy Now!”
button below to download the
complete manual.



After you pay.

You can download the most
perfect and complete manual in
the world immediately.

Our support email:

ebooklibonline@outlook.com