

OPERATOR'S MANUAL

PENDULAR SPREADERS

SS1079P

SS1116P

SS1180P

SS1220P

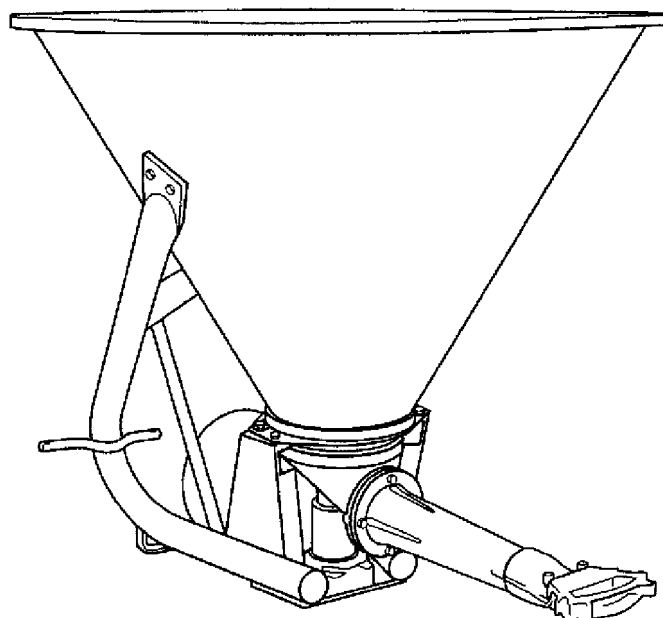

Manual 5BP960378B
Date 06/14/2011

SAFETY

Take note! This safety alert symbol found throughout this manual is used to call your attention to instructions involving your personal safety and the safety of others. Failure to follow these instructions can result in injury or death.



This symbol means:
ATTENTION!
BECOME ALERT!
YOUR SAFETY IS INVOLVED!

Signal Words

Note the use of the signal words DANGER, WARNING and CAUTION with the safety messages. The appropriate signal words for each have been selected using the following guidelines:



DANGER: Indicates an imminently hazardous situation that, if not avoided, will result in death or serious injury.



WARNING: Indicates a potentially hazardous situation that, if not avoided, could result in death or serious injury, and includes hazards that are exposed when guards are removed. It may also be used to alert against unsafe practices.



CAUTION: Indicates a potentially hazardous situation that, if not avoided, may result in minor or moderate injury.

INDEX

1 - GENERAL INFORMATION	4
1.01 - General	4
1.02 - Warranty Information	4
1.03 - Model and Serial Number ID	5
2 - SAFETY PRECAUTIONS	6
2.01 - Preparation	6
2.02 - Starting and Stopping	7
2.03 - Messages and Signs	7
3 - OPERATION	10
3.01 - Operational Safety	10
3.02 - Set Up and Assembly	12
3.03 - Pre-Operational Check	13
3.04 - Attaching to the Tractor	14
3.05 - Start Up	15
3.06 - Operating Techniques	16
3.07 - Uneven Terrain	17
3.08 - Optional Filter Grate	17
3.09 - Optional Agitator Extension	17
3.10 - Optional Sand & Salt Spout	18
3.11 - Optional Rubber Insert	18
3.12 - Optional Hydraulic Gate Control	18
3.13 - Optional Left/Right Directional Attachment	19
3.14 - Optional Locking Nut for Spout	19
3.15 - Optional Hopper Cover	20
3.16 - Spreading Charts	20
4 - MAINTENANCE	24
4.01 - Maintenance Safety	24
4.02 - Service	25
4.03 - Driveline	26
4.04 - Safety Shear Bolt	28
4.05 - Transport	28
5 - REPAIR PROCEDURES	30
5.01 - Suggested Spare Parts	30
5.02 - Storage	30
6 - TROUBLESHOOTING	31
7 - PRE-DELIVERY CHECKLIST	32
PARTS MANUAL	33

1 - GENERAL INFORMATION

Thank you and congratulations for having chosen our implement. Your new pendular spreader is a technologically advanced machine constructed of high quality, sturdy components that will fulfill your working expectations. Read this manual carefully. It will instruct you on how to operate and service your implement safely and correctly. Failure to do so could result in personal injury and/or in equipment damage.

1.01 - General

The implement described in this manual is to be used with tractors with PTO at 540 rpm and clockwise rotation.



CAUTION: Always ensure that the coupling of the implement with the tractor is done at the same PTO speed and direction of rotation. Do not operate this implement at a PTO speed or direction of rotation other than that shown on the implement. Serious damage can occur to the machine and/or the operator.



CAUTION: Unless otherwise specified, all hardware is metric. Use only metric tools on metric hardware. Other tools that do not fit properly can slip and cause injury.



CAUTION: Right hand and left hand sides of the implement are determined by facing in the direction the implement will travel when going forward (see fig. 2).

1.02 - Warranty Information

Warranty coverage is provided by John Deere according to the terms of the Agricultural/Commercial & Consumer Equipment Warranty Statement. Carefully read the warranty statement on the back of your original purchase order for details on coverage and limitations of this warranty.

Your Authorized Company Dealer has genuine parts in stock. Only these approved replacement parts should be used.

1.03 - Model and Serial Number ID

Attached to the frame is an ID plate showing the model and the serial number. Record your implement model and serial number in the space provided below. Your dealer needs this information to give you prompt, efficient service when you order parts.



2 - SAFETY PRECAUTIONS

Safety is the primary concern in the design and manufacture of our products. Unfortunately our efforts to provide safe equipment can be wiped out by a single careless act of an operator.

In addition to the design and configuration of equipment, hazard control and accident prevention are dependent upon the awareness, concern, prudence and proper training of personnel involved in the operation, transport, maintenance and storage of equipment.

It is the operator's responsibility to read and understand all safety and operating instructions in the manual and to follow these.

Allow only properly trained personnel to operate the fertilizer spreader. Working with unfamiliar equipment can lead to careless injuries. Read this manual, and the manual for your tractor, before assembly or operation, to acquaint yourself with the machines. It is the spreader owner's responsibility, if this machine is used by any person other than yourself, is loaned or rented, to make certain that the operator, prior to operating, reads and understands the Operator's Manuals and is instructed in safe and proper use.

2.01 - Preparation



1. Before operating equipment read and understand the Operator's Manual and the safety signs (**see fig. 2**).
2. Thoroughly inspect the implement before initial operation to assure that all packaging materials, i.e., wires, bands, and tape have been removed.
3. Personal protection equipment including hard hat, safety glasses, safety shoes, and gloves are recommended during assembly, installation, operation, adjustment, maintaining and/or repairing the implement.
4. Operate the fertilizer spreader only with a tractor equipped with an approved Roll-Over-Protective-System (ROPS). Always wear your seat belt. Serious injury or even death could result from falling off the tractor.
5. Clear area of stones, branches or other debris that might be thrown, causing injury or damage.
6. Operate only in daylight or good artificial light.
7. Ensure fertilizer spreader is properly mounted, adjusted and in good operating condition.
8. Ensure that all safety shielding and safety signs are properly installed and in good condition.
9. Chemicals may cause eye, skin or breathing problems. Always wear a face mask, gloves and goggles when filling hopper.
10. Before loading the fertilizer in the hopper read carefully the instructions printed on the fertilizer canvas bag concerning the precautions to be taken in case of toxicity or

corrosivity of the product. Before loading switch off the engine and remove the ignition key.

11. Load hopper with product only after the spreader has been properly attached to the tractor.

2.02 - Starting and Stopping



1. Be sure that no one is near the machine prior to engaging or while the machine is working.
2. Be sure the tractor is in "Neutral" before starting engine.
3. The operating power is supplied from tractor PTO. Refer to your tractor manual for PTO engagement and disengagement instructions. Always operate PTO at 540 rpm. Know how to stop the tractor and machine quickly in case of an emergency.
4. When engaging PTO, the engine rpm should always be low. Once engaged and ready to start operating, raise PTO speed to 540 rpm and maintain throughout operation.
5. Check the tractor master shield over the PTO stub shaft. Make sure it is in good condition and fastened securely to the tractor. Purchase a new shield if old shield is damaged or missing.
6. After striking an obstacle, disengage the PTO, shut the tractor down and thoroughly inspect for damage before restarting.
7. To park the vehicle safely, stop vehicle on a level surface (not on a slope), disengage PTO, engage the parking brake, stop the engine, remove the key, and wait for engine and all moving parts to stop before leaving the operator's seat.
8. Stay clear of rotating drivelines. Entanglement in rotating driveline can cause serious injury or death. Wear close fitting clothing. Stop the engine and be sure PTO driveline is stopped before getting near it.

2.03 - Messages and Signs



1. Read and adhere to all safety and operating decals on this machine (**see fig. 2**).
 2. Before dismounting tractor: Stop engine, set brake and remove the key of unattended equipment.
 3. Keep away from rotating parts and driveline.
 4. Keep guards and shields in place and in good condition.
 5. Do not use with bystanders in area.
 6. Allow no riders on tractor or fertilizer spreader.
 7. Allow moving parts to stop before repair.
 8. Securely support fertilizer spreader before working underneath.
- Additional warning and operating decals are available at no extra charge. Please specify model and serial number when ordering.

Fig. 2 - Safety decals - implement; replace immediately if damaged.

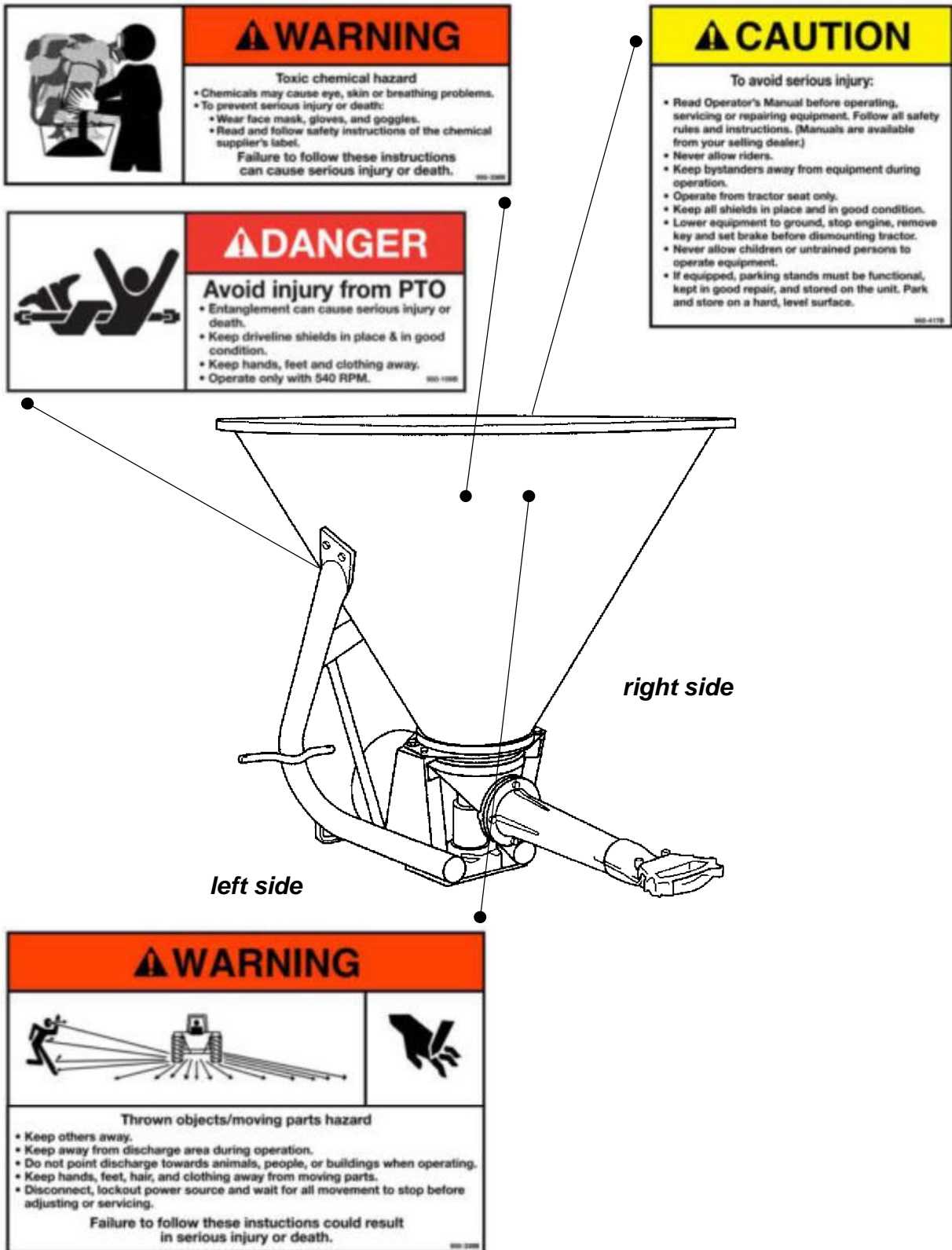

Thank you so much for reading.
Please click the “Buy Now!”
button below to download the
complete manual.



After you pay.

You can download the most
perfect and complete manual in
the world immediately.

Our support email:

ebooklibonline@outlook.com