

OPERATOR'S MANUAL

SOIL PULVERIZERS

SP2048

SP2060

SP2072

SP2272

SP2284

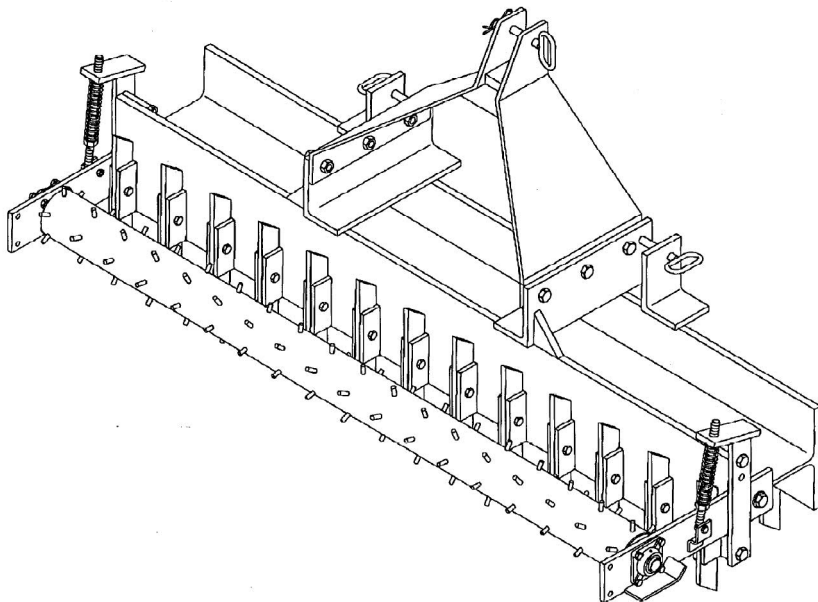

FRONTIER
EQUIPMENT

Manual 5BP960387B

Date 10/11/2008

SAFETY

Take note! This safety alert symbol found throughout this manual is used to call your attention to instructions involving your personal safety and the safety of others. Failure to follow these instructions can result in injury or death.



*This symbol means:
ATTENTION!
BECOME ALERT!
YOUR SAFETY IS INVOLVED!*

Signal Words

Note the use of the signal words DANGER, WARNING and CAUTION with the safety messages. The appropriate signal words for each have been selected using the following guidelines:



DANGER: Indicates an imminently hazardous situation that, if not avoided, will result in death or serious injury.



WARNING: Indicates a potentially hazardous situation that, if not avoided, could result in death or serious injury, and includes hazards that are exposed when guards are removed. It may also be used to alert against unsafe practices.



CAUTION: Indicates a potentially hazardous situation that, if not avoided, may result in minor or moderate injury.

INDEX

1 - GENERAL INFORMATION	4
1.01 - General	4
1.02 - Model and Serial Number ID	4
1.03 - Assembly Instructions	5
2 - SAFETY PRECAUTIONS	6
2.01 - Preparation	6
2.02 - Starting and Stopping	7
2.03 - Messages and Signs	7
3 - OPERATION	9
3.01 - Operational Safety	9
3.02 - Setup	11
3.03 - Pre-Operational Check	11
3.04 - Attaching to the Tractor	11
3.05 - Start Up	12
3.06 - Top Link and Roller Adjustments	12
3.07 - Working Speed	13
3.08 - Operating Techniques	13
3.09 - Uneven Terrain	13
4 - MAINTENANCE	14
4.01 - Maintenance Safety	14
4.02 - Service	15
5 - REPAIR PROCEDURES	18
5.01 - Suggested Spare Parts	18
5.02 - Storage	18
6 - TROUBLESHOOTING	19
7 - PRE-DELIVERY CHECKLIST	20
PARTS MANUAL	21

1 - GENERAL INFORMATION

Thank you and congratulations for having chosen our implement. Your new soil pulverizer is a technologically advanced machine constructed of high quality, sturdy components that will fulfill your working expectations. Read this manual carefully. It will instruct you on how to operate and service your implement safely and correctly. Failure to do so could result in personal injury and/or in equipment damage.

1.01 - General



CAUTION: Unless otherwise specified, all hardware is metric. Use only metric tools on metric hardware. Other tools that do not fit properly can slip and cause injury.



CAUTION: Right hand and left hand sides of the implement are determined by facing in the direction the implement will travel when going forward (see fig. 2).

1.02 - Model and Serial Number ID

Attached to the frame is an ID plate showing the model and the serial number. Record your implement model and serial number in the space provided below. Your dealer needs this information to give you prompt, efficient service when you order parts.



Warranty coverage is provided by John Deere according to the terms of the Agricultural/Commercial & Consumer Equipment Warranty Statement. Carefully read the warranty statement on the back of your original purchase order for details on coverage and limitations of this warranty.

Your Authorized Company Dealer has genuine parts in stock. Only these approved replacement parts should be used.

1.03 - Assembly Instructions

Note: Refer to the Parts Manual for an illustration of the parts referenced in the instructions below.

1. Remove top and side panels from crate.
2. Remove "A" frame from crate. It is wired to the machine for transporting purposes.
3. Remove main frame of soil pulverizer using an overhead chain hoist.
4. The bolts (**see Parts Manual**) that secure the "A" frame to the main frame of the machine are shipped mounted in the holes on the main frame. Remove the bolts and nuts.
5. Mount the "A" frame onto the mainframe and secure it with the bolts and nuts that were removed during the step 4.
6. Install the manual holder with the bolts supplied inside the container to the holes in the "A" frame. Please be sure to mount the container with the side that opens toward the tractor. Place the Operator's Manual inside the manual holder.



CAUTION: Stand clear of bands when cutting as they could be under sufficient tension to cause them to fly loose. Take care in removing bands and wire. They often have extremely sharp edges and cut very easily.

2 - SAFETY PRECAUTIONS

Safety is the primary concern in the design and manufacture of our products. Unfortunately our efforts to provide safe equipment can be wiped out by a single careless act of an operator.

In addition to the design and configuration of equipment, hazard control and accident prevention are dependent upon the awareness, concern, prudence and proper training of personnel involved in the operation, transport, maintenance and storage of equipment. It is the operator's responsibility to read and understand all safety and operating instructions in the manual and to follow these.

Allow only properly trained personnel to operate the implement. Working with unfamiliar equipment can lead to careless injuries. Read this manual, and the manual for your tractor, before assembly or operating, to acquaint yourself with the machines. It is the owner's responsibility, if this machine is used by any person other than yourself, is loaned or rented, to make certain that the operator, prior to operating, reads and understands the operator's manuals and is instructed in safe and proper use.

2.01 - Preparation



1. Before operating equipment read and understand the operator's manual and the safety signs (**see fig. 2**).
2. Thoroughly inspect the implement before initial operation to assure that all packaging materials, i.e. wires, bands, and tape have been removed.
3. Personal protection equipment including hard hat, safety glasses, safety shoes, and gloves are recommended during assembly, installation, operation, adjustment, maintaining and/or repairing the implement.
4. Operate the implement only with a tractor equipped with an approved Roll-Over-Protective-System (ROPS). Always wear your seat belt. Serious injury or even death could result from falling off the tractor.
5. Clear area to be cut of stones, branches or other debris that might be thrown, causing injury or damage.
6. Operate only in daylight or good artificial light.
7. Ensure implement is properly mounted, adjusted and in good operating condition.
8. Ensure that all safety decals are properly installed and in good condition.

2.02 - Starting and Stopping



1. Be sure that no one is near the machine prior to engaging or while the machine is working.
2. Be sure the tractor is in "Neutral" before starting engine.
3. Equipment operating power is ground driven. Know how to stop the tractor quickly in case of an emergency.
4. After striking an obstacle, shut the tractor off, remove key and thoroughly inspect for damage before restarting.

2.03 - Messages and Signs



1. Read and adhere to all safety and operating decals on this machine (**see fig. 2**).
2. Before dismounting tractor: allow moving parts to stop, stop engine, set brake and remove the key of unattended equipment.
3. Keep safety decals in place and in good condition.
4. Do not use with bystanders in area.
5. Allow no riders on tractor or implement.
6. Allow moving parts to stop before repair.
7. Securely support implement before working underneath.

Additional warning and operating decals are available at no extra charge. Please specify model and serial number when ordering.

Fig. 2 - Safety decals; replace immediately if damaged.

CAUTION

To avoid serious injury:

- Read Operator's Manual before operating, servicing or repairing equipment. Follow all safety rules and instructions. (Manuals are available from your selling dealer.)
- Never allow riders.
- Keep bystanders away from equipment during operation.
- Operate from tractor seat only.
- Keep all shields in place and in good condition.
- Lower equipment to ground, stop engine, remove key and set brake before dismounting tractor.
- Never allow children or untrained persons to operate equipment.
- If equipped, parking stands must be functional, kept in good repair, and stored on the unit. Park and store on a hard, level surface.

950-117B

WARNING



Crushing and Pinching Hazard

- Be extremely careful handling various parts of the hitching mechanism. They are heavy and hands, fingers, feet, and other body parts could be crushed or pinched between tractor and implement.
- Operate tractor controls from tractor seat only.
- Do not stand between tractor and implement when tractor is in gear.
- Make sure parking brake is engaged before going between tractor and implement.
- Stand clear of machine while in operation or when it is being raised or lowered.

Failure to follow these instructions could result in serious injury or death.

950-407B

WARNING

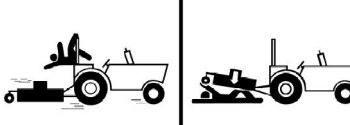

Falling off can result in being run over.

- Tractor must be equipped with ROPS (or ROPS CAB) and seat belt. Keep foldable ROPS system in "locked up" position at all times.
- Buckle up! Keep seat belt securely fastened.
- Allow no riders.

Raised equipment can drop and crush.

- Before working underneath, follow all instructions and safety rules in operator's manual and securely block all corners of equipment with jack stands.
- Securely blocking prevents equipment dropping from hydraulic leakdown, hydraulic system failures or mechanical component failures.

Falling off or failing to block securely can result in serious injury or death.

950-408B

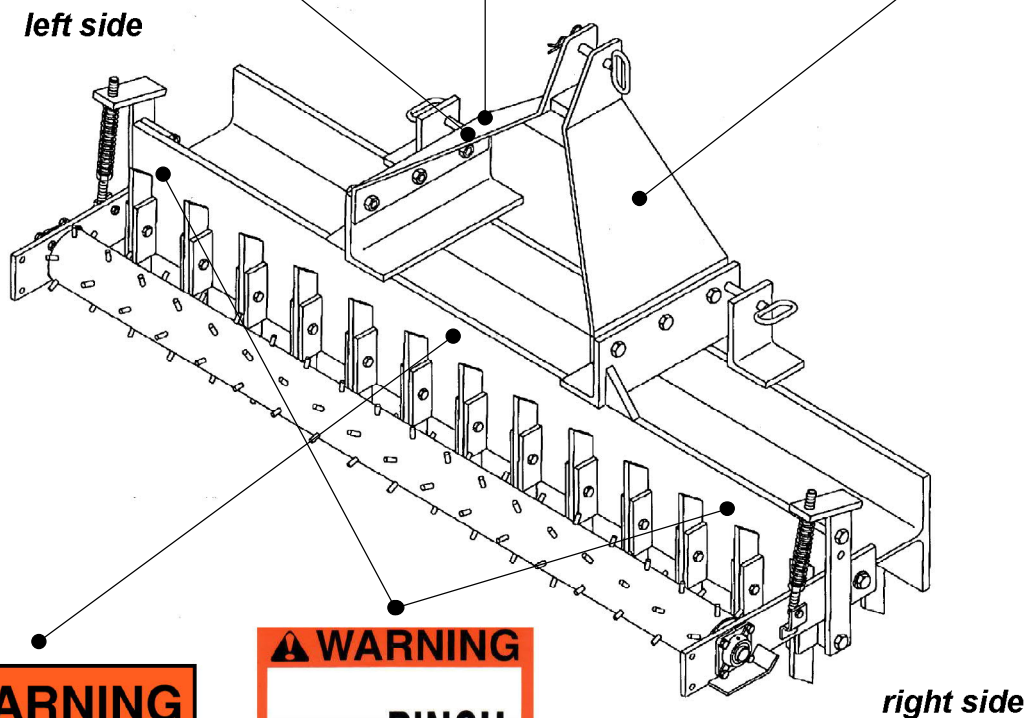

WARNING

Falling hazard

- Do not stand on roller.

Failure to follow these instructions could result in serious injury.

950-419R

WARNING



PINCH POINT

322 B

Thank you so much for reading.
Please click the “Buy Now!”
button below to download the
complete manual.



After you pay.

You can download the most
perfect and complete manual in
the world immediately.

Our support email:

ebooklibonline@outlook.com