

OPERATOR'S MANUAL

FRONT BLADE

MODEL FB1018 FB1021 FB1121 FB1024



OPERATOR'S MANUAL
Front Blade



John Deere SE Asia

Introduction:

READ THIS MANUAL carefully to learn how to operate and service your machine correctly. Failure to do so could result in personal injury or equipment damage.

THIS MANUAL SHOULD BE CONSIDERED a permanent part of your machine and should remain with the machine when you sell it.

MEASUREMENTS in this manual are given in both metric and customary U.S. unit equivalents. Use only correct replacement parts and fasteners. Metric and inch fasteners may require a specific metric or inch wrench.

RIGHT-HAND AND LEFT-HAND sides are determined by facing in the direction of forward travel.

WRITE PRODUCT IDENTIFICATION NUMBERS (P.I.N.) in the Specification or Identification Numbers Section.

Accurately record all the numbers to help in tracing the machine should it be stolen. File the identification numbers in a secure place; do not keep them on the machine.

WARRANTY is provided as part of John Deere's support program for customers who operate and maintain their equipment as described in this manual. The warranty is explained on the warranty certificate which you should have received from your dealer.

This warranty provides you the assurance that John Deere will back its products where defects appear within the warranty period. In some circumstances, John Deere also provides field improvements, often without charge to the customer, even if the product is out of warranty.

Should the equipment be abused, or modified to change its performance beyond the original factory specifications, the warranty will become void and field improvements may be denied.

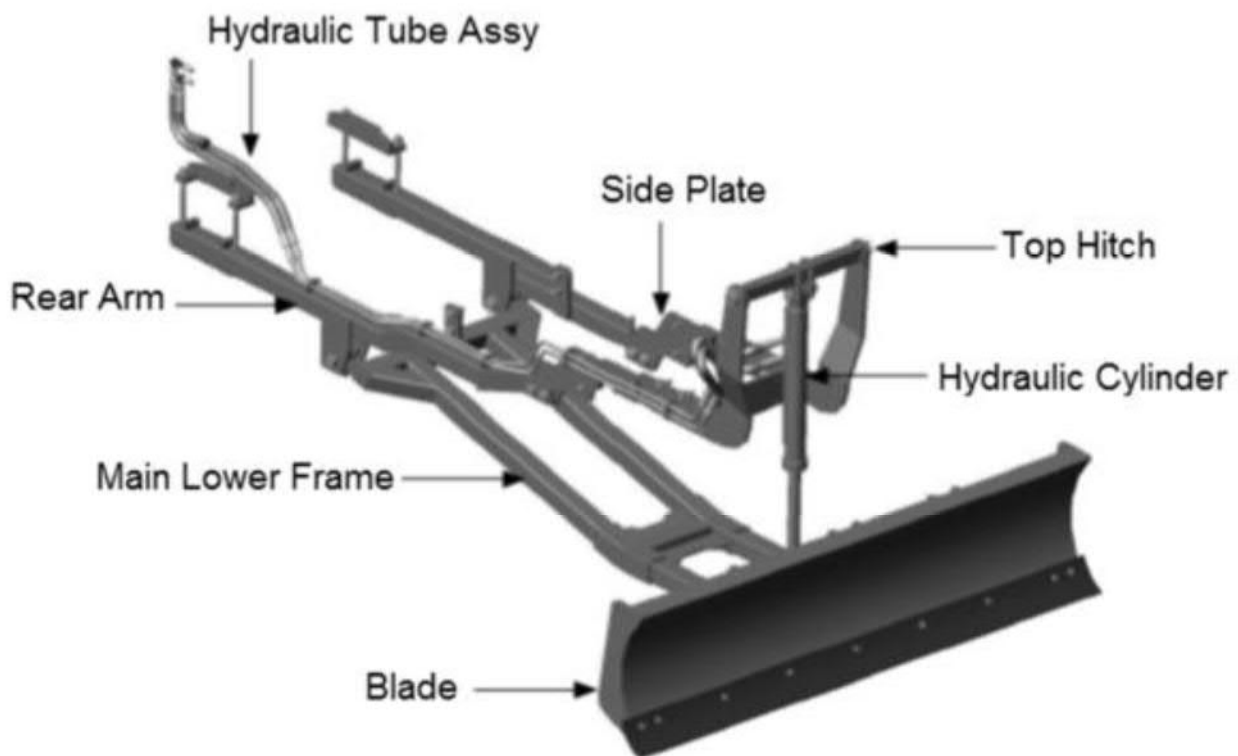

A Message to Our Customers

We appreciate the confidence placed in us by your purchase of this machine. Before this machine was brought to the market, countless hours were spent designing and testing to ensure that its performance would be at the highest level. To achieve maximum performance, it is imperative this machine be operated in accordance with the procedures outlined in this manual.

Information in this manual is divided into sections. These sections are identified at the top of each page. Specific information within each section is organized into modules. These modules are encased in boxes with principle modules identified with a heading at the top left side of the box.

Two-part page numbers identify both the section and page of that section.

By reviewing this manual often, one will quickly learn which section to go to for specific information.

For instance, machine adjustments would be found in the Operating Machine section, lubrication intervals in the Lubrication section, opener maintenance in the Service section, etc. A detailed Table of Contents is found immediately behind this page, and an Index is provided at the back of the manual.

Thank you very much for purchasing this machine.

Customer Responsibility

It is the Customer or Operator's responsibility to read the Operator's Manual, to operate, lubricate, maintain and store the product in accordance with all instructions and safety procedures. Failure of the operator to read the Operator's Manual is a misuse of this equipment.

It is the Customer's or Operator's responsibility to inspect the product and to have any parts repaired or replaced when continued operation would cause damage or excessive wear to other parts or cause safety hazards.

It is the Customer's responsibility to deliver the product to Authorized Dealer, from whom they purchased it, for service or replacement of defective parts which are covered by warranty. Repairs to be submitted for warranty consideration must be made within thirty days (30) of failure.

It is the Customer's responsibility for any cost incurred by the Dealer for travelling to or hauling of the product for the purpose of performing a warranty obligation or inspection.

Contents

	Page		Page
Inspection Checklists		Attaching and Detaching the Front Blade	
Pre-Delivery Inspection	6	Use Your Tractor Operator's Manual	18
Owner's Record.....	6	Tractor Requirement.....	18
Delivery Inspection	6	Installation and assembly.....	19
After-Sales Inspection	7		
Inspection Before Each Day of Operation	7	Transporting	
Inspection Before Each Season	7	Transporting	25
		Operating the Front Blade	
Safety		Parking	26
Recognize safety information.....	8	Field Operation	26
Understand Signal Words.....	8		
Follow Safety Instructions.....	8	Lubrication and Maintenance	
Operate Machine Safely	9	Safe Lubrication and Maintenance of the Blade.....	27
Keep Riders Off Machine	9	Lubrication and Maintenance Procedures	27
Avoid Rollover Accident.....	9	Grease.....	28
Wear Protective Clothing.....	10	Lubrication Symbols	28
Use Safety Lights and Devices.....	10	Alternative Lubricants	28
Transport Safety	11	Lubrication of Front Blade.....	29
Tow Loads Safely	12	Daily or Every 8 Hours Work	29
Comply with the Transport Speed Limit.....	12	Weekly or Every 50 Hours Work	29
Service Machine Safely	12	Every 400 Hours Work	29
Practice Safe Maintenance.....	13	Every 1000 Hours Work	29
Remove Paint Before Welding or Heating.....	13	Practice Safe Maintenance.....	30
Store Attachments Safely	14	Metric Bolt and Screw Torque Values.....	31
Dispose of Waste Properly	14	Unified Inch Bolt and Screw Torque Values.....	32
		Supporting Raised Machine	33
Safety Signs		Maintenance of Front Blade.....	33
Safety Sign Locations.....	15	Blade Replacement	34
Caution - Read Operator Manual	16	Storage	34
Caution - High pressure fluid injection into body	16		
Caution – Cutting of foot.....	16	Troubleshooting	
		Front Blade.....	35
Preparing the Tractor			
Use Your Tractor Operator's Manual	17	Specifications	
Front Counterweight	17	Specifications	36
Rear Wheel Counterweight	17	Serial Number.....	36
Determining Front End Ballast Without		Keep blade Secure	36
Implement Codes	17	Parts List.....	38
Tightening Hardware	17		

Original Instructions. All information, illustrations and specifications in this manual are based on the latest information available at the time of publication. The right is reserved to make changes at any time without notice

Thank you so much for reading.
Please click the “Buy Now!”
button below to download the
complete manual.



After you pay.

You can download the most
perfect and complete manual in
the world immediately.

Our support email:

ebooklibonline@outlook.com