

# OPERATOR'S MANUAL

## ROTARY TILLER

MODEL RT4019



# OPERATOR'S MANUAL

## Rotary Tiller



**Introduction:**

READ THIS MANUAL carefully to learn how to operate and service your machine correctly. Failure to do so could result in personal injury or equipment damage.

THIS MANUAL SHOULD BE CONSIDERED a permanent part of your machine and should remain with the machine when you sell it.

MEASUREMENTS in this manual are given in both metric and customary U.S. unit equivalents. Use only correct replacement parts and fasteners. Metric and inch fasteners may require a specific metric or inch wrench. RIGHT-HAND AND LEFT-HAND sides are determined by facing in the direction of forward travel.

WRITE PRODUCT IDENTIFICATION NUMBERS (P.I.N.) in the Specification or Identification Numbers Section.

Accurately record all the numbers to help in tracing the machine should it be stolen. File the identification numbers in a secure place; do not keep them on the machine.

WARRANTY is provided as part of John Deere's support program for customers who operate and maintain their equipment as described in this manual. The warranty is explained on the warranty certificate which you should have received from your dealer.

This warranty provides you the assurance that John Deere will back its products where defects appear within the warranty period. In some circumstances, John Deere also provides field improvements, often without charge to the customer, even if the product is out of warranty.

Should the equipment be abused, or modified to change its performance beyond the original factory specifications, the warranty will become void and field improvements may be denied.

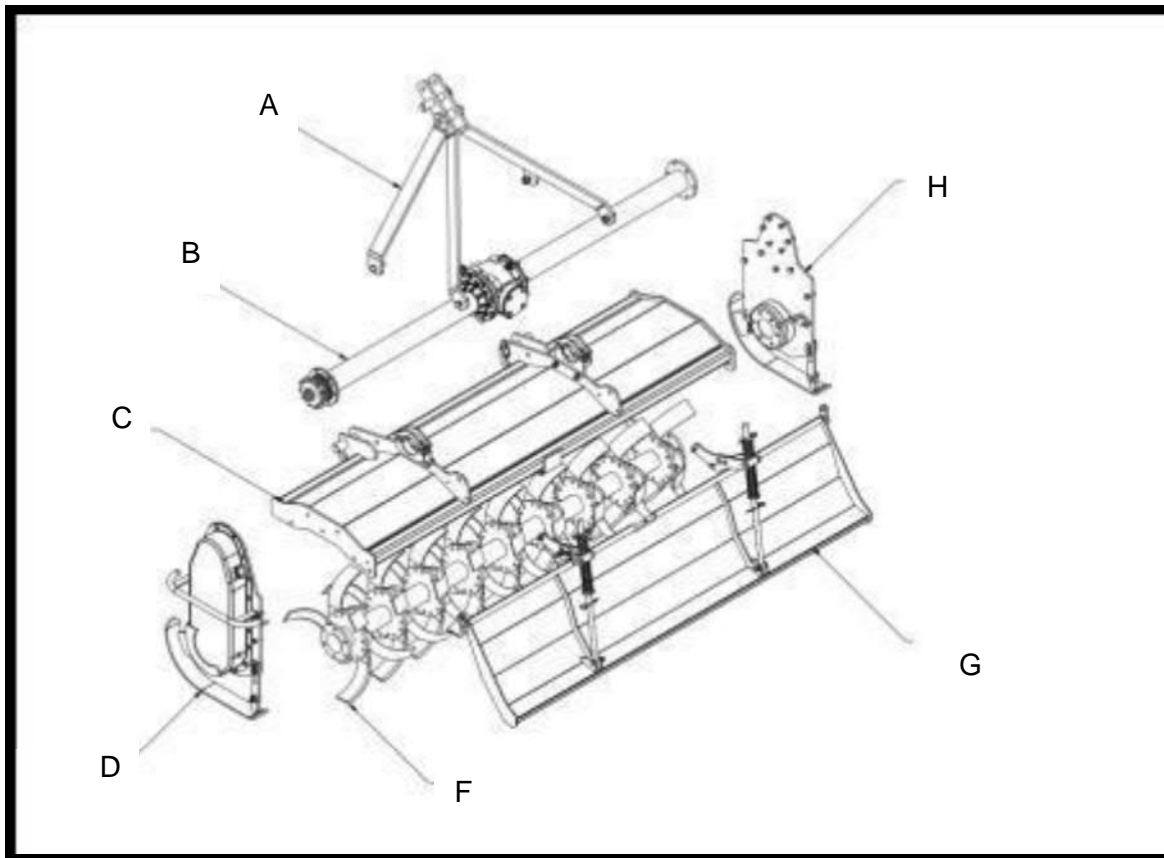

A – Top Hitch

B – Gear Box / Extension

C – Main Frame

D – Chain Side Plate

F – Blade Shaft

G – Back Cover

H – Side Plate and Blade Bearing Assembly Set

## **A Message to Our Customers**

We appreciate the confidence placed in us by your purchase of this machine. Before this machine was brought to the market, countless hours were spent designing and testing to ensure that its performance would be at the highest level. To achieve maximum performance, it is imperative this machine be operated in accordance with the procedures outlined in this manual. Information in this manual is divided into sections. These sections are identified at the top of each page. Specific information within each section is organized into modules. These modules are encased in boxes with principle modules identified with a heading at the top left

side of the box. Two-part page numbers identify both the section and page of that section.

By reviewing this manual often, one will quickly learn which section to go to for specific information. For instance, machine adjustments would be found in the Operating Machine section, lubrication intervals in the Lubrication section, opener maintenance in the Service section, etc. A detailed Table of Contents is found immediately behind this page, and an Index is provided at the back of the manual.

Thank you very much for purchasing this machine.

## **Customer Responsibility**

It is the Customer or Operator's responsibility to read the Operator's Manual, to operate, lubricate, maintain and store the product in accordance with all instructions and safety procedures. Failure of the operator to read the Operator's Manual is a misuse of this equipment.

It is the Customer's or Operator's responsibility to inspect the product and to have any parts repaired or replaced when continued operation would cause damage or excessive wear to other parts or cause safety hazards.

It is the Customer's responsibility to deliver the product to Authorized Dealer, from whom they purchased it, for service or replacement of defective parts which are covered by warranty. Repairs to be submitted for warranty consideration must be made within thirty days (30) of failure.

It is the Customer's responsibility for any cost incurred by the Dealer for travelling to or hauling of the product for the purpose of performing a warranty obligation or inspection.

# Contents

## Page

### Inspection Checklists

Pre-Delivery Inspection .....	6
Owner's Record .....	6
Delivery Inspection .....	6
After-Sales Inspection .....	7
Inspection Before Each Day of Operation .....	7
Inspection Before Each Season .....	7

### Safety

Recognize safety information .....	11
Understand Signal Words .....	11
Follow Safety Instructions .....	11
Prevent Machine Runaway .....	11
Operate Machine Safely .....	12
Keep Riders Off Machine .....	12
Prepare for Emergencies .....	13
Wear Protective Clothing .....	13
Use Safety Lights and Devices .....	14
Transport Safety .....	14
Tow Loads Safely .....	15
Comply with the Transport Speed Limit .....	15
Service Machine Safely .....	15
Practice Safe Maintenance .....	16
Remove Paint Before Welding or Heating .....	16
Store Attachments Safely .....	16
Dispose of Waste Properly .....	16

### Safety Signs

Safety Sign Locations .....	17
Caution - Read Operator Manual .....	18
Warning - Fallen Objects .....	18
Warning - Crush Hazard .....	18
Warning - Transport Safely .....	19

### Preparing the Tractor

Use Your Tractor Operator's Manual .....	20
Front Counterweight .....	20
Rear Wheel Counterweight .....	20
Determine Front End Ballast W/O Implement Codes .....	21

## Page

### Attaching and Detaching the Rotary Tiller

Use Your Tractor Operator's Manual .....	21
Tractor Requirement .....	21
Attaching Rotary Tiller to Tractor .....	21

### Transporting

Transport Safely .....	22
Transporting .....	22

### Operating the Rotary Tiller

Parking .....	24
Field Operation .....	25

### Adjustments

Blade angle Adjustment .....	27
------------------------------	----

### Lubrication and Maintenance

Safe Lubrication and Maintenance .....	30
Lubrication and Maintenance Procedures .....	30
Grease .....	30
Lubrication Symbols .....	31
Alternative Lubricants .....	31
Lubrication of Rotary Tiller .....	31
Daily or Every 8 Hours Work .....	32
Weekly or Every 50 Hours Work .....	32
Every 400 Hours Work .....	32
Every 1000 Hours Work .....	33
Drive line Shaft (Propeller Shaft) .....	33
Greasing Points .....	34
Practice Safe Maintenance .....	35
Metric Bolt and Screw Torque Values .....	36
Unified Inch Bolt and Screw Torque Values .....	37
Supporting Raised Machine .....	38
Maintenance of Rotary Tiller .....	39
Blade Replacement .....	39
Storage .....	39

### Troubleshooting

Rotary Tiller .....	40
Specifications .....	41
Serial Number .....	41
Keep Machined Secure .....	41
Parts Catalogue .....	43
Warranty Statement .....	55

*Original Instructions. All information, illustrations and specifications in this manual are based on the latest information available at the time of publication. The right is reserved to make changes at any time without notice*

Thank you so much for reading.  
Please click the “Buy Now!”  
button below to download the  
complete manual.



After you pay.

You can download the most  
perfect and complete manual in  
the world immediately.

Our support email:

[ebooklibonline@outlook.com](mailto:ebooklibonline@outlook.com)