

O P E R A T O R ' S M A N U A L

Drawn Box Scraper

LL1372

LL1384

LL1396

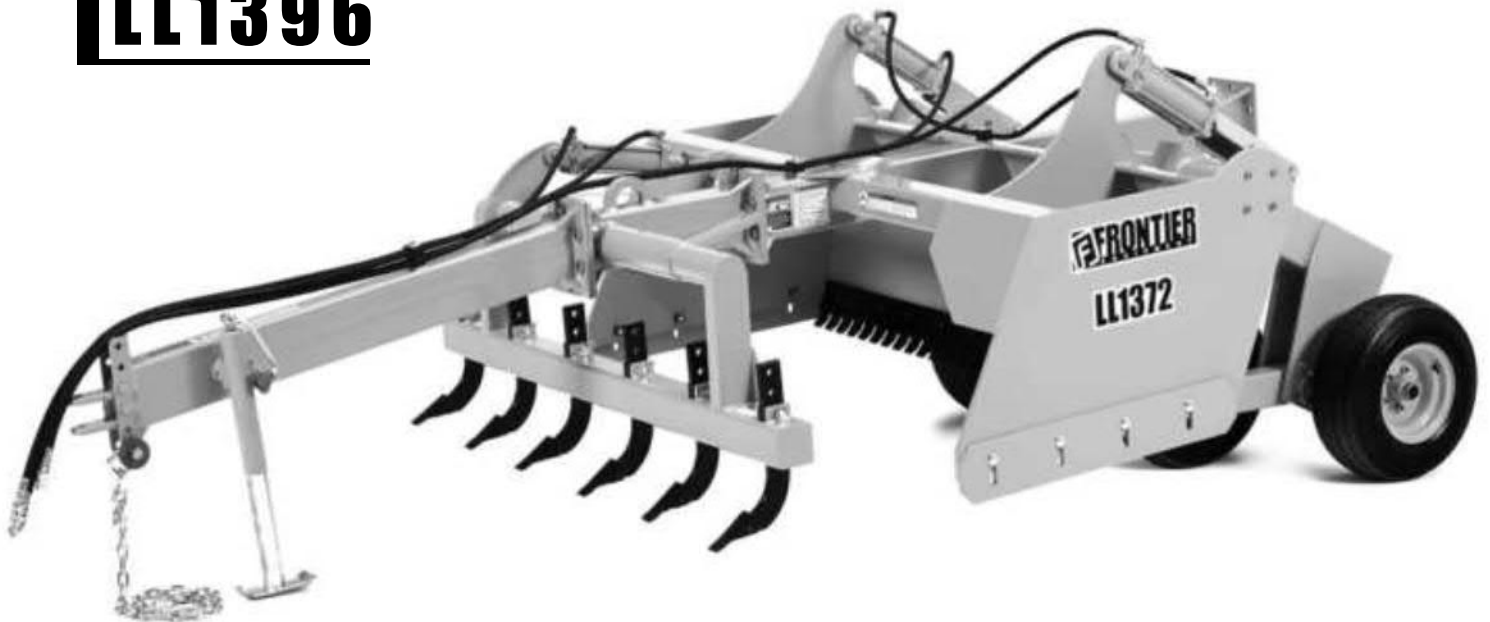

FRONTIER
EQUIPMENT

TABLE OF CONTENTS

INTRODUCTION	ii
SPECIFICATIONS / GENERAL INFORMATION	1, 2
SAFETY DECALS	3, 4
SAFETY RULES	5 - 7
DEALER INSTRUCTIONS	8
OPERATION.	10 - 14
OWNERS RESPONSIBILTY	10, 11
SET UP	11, 12
MAINTENANCE	12
LUBRICATION	13
HYDRAULICS	14
PARTS CATALOG	15 - 17
OPTIONAL EQUIPMENT	18 - 31
BOLT AND BOLT TORQUE CHART.	32
WARRANTY	33
WARRANTY FOR PARTS	34

GENERAL INFORMATION

The purpose of this manual is to assist you in operating and maintaining your drawn box scraper. Read it carefully. It furnishes information and instructions that will help you achieve years of dependable performance.

These instructions have been compiled from field experience and engineering data. Some information may be general in nature, due to unknown and varying operating conditions. However, through experience and these instructions, you should be able to develop procedures suitable to

your particular situation.

The illustrations and data used in this manual were current at the time of printing. However, due to possible inline production changes, your machine may vary slightly in detail. We reserve the right to redesign and change the machines as may be necessary without notification.

Throughout this manual, references are made to right and left direction. These are determined by standing behind the tractor facing the direction of forward travel.

LL13 SERIES BASE UNIT SPECIFICATIONS

Model	LL1372	LL1384	LL1396
Tractor HP	35-100	35-125	35-125
Working Width	6 Feet	7 Feet	8 Feet
Machine Width	6 Feet 2 Inches	7 Feet 2 Inches	8 Feet 2 Inches
Machine Length	13 Feet 9 Inches	13 Feet 9 Inches	13 Feet 9 Inches
Machine Height	49 Inches	49 Inches	49 Inches
Operating Weight	1600 lbs	1866 lbs.	2133 lbs
Hitch Type	Drawn	Drawn	Drawn
Cutting Edge	6 Inches Tall, 5/8 Thick Grading Blade	6 Inches Tall, 5/8 Thick Grading Blade	6 Inches Tall, 5/8 Thick Grading Blade
Moldboard Thickness	3/8 Inch	3/8 Inch	3/8 Inch
End Plate Thickness	1/2 Inch	1/2 Inch	1/2 Inch
Hydraulic Cylinders	Standard	Standard	Standard
Hydraulic Cylinders (#)	2	2	2
Cylinder Size	3.25, 3.0	3.25, 3.0	3.25, 3.0
Cylinder Rod Size	1 3/8 Inches	1 3/8 Inches	1 3/8 Inches
Cylinder Stroke Length	8	8	8
Safety Chains	Standard	Standard	Standard
Duty	Construction	Construction	Construction
Warranty	6 Months Warranty	6 Months Warranty	6 Months Warranty

LL13 SERIES OPTIONAL EQUIPMENT SPECIFICATIONS

Model	LL1372	LL1384	LL1396
Hydraulic Scarifiers	Optional Attachment	Optional Attachment	Optional Attachment
Length	21 Inches	21 Inches	21 Inches
Width	6 Feet	6 Feet	8 Feet
Replaceable Tips	Yes	Yes	Yes
Number of Scarifiers	6	6	8
Hydraulic Cylinders (#)	1	1	1
Cylinder Size	3.0 Bore	3.0 Bore	3.0 Bore
Cylinder Rod Size	1 3/8 Inches	1 3/8 Inches	1 3/8 Inches
Cylinder Stroke Length	8	8	8
Time required to attach	Approximately 45 minutes	Approximately 45 minutes	Approximately 45 minutes

LL13 SERIES OPTIONAL EQUIPMENT SPECIFICATIONS

Model	LL1372	LL1384	LL1396
Smooth Rear Drum Roller	Optional Attachment	Optional Attachment	Optional Attachment
Length	35 Inches	35 Inches	35 Inches
Width	6 Feet	7 Feet	8 Feet
Roller Diameter	12 Inches	12 Inches	12 Inches
Hydraulic Cylinders (#)	Not Required	Not Required	Not Required
Time required to attach	Approximately 30 Minutes	Approximately 30 Minutes	Approximately 30 Minutes
3 Bar Spring Tine Harrow	Optional Attachment	Optional Attachment	Optional Attachment
Length	5 Feet	5 Feet	5 Feet
Width	6 Feet	7 Feet	8 Feet
Hydraulic Cylinders (#)	Not Required	Not Required	Not Required
Time required to attach	Approximately 30 Minutes	Approximately 30 Minutes	Approximately 30 Minutes
8" Diameter Single Basket Roller	Optional Attachment	Optional Attachment	Optional Attachment
Length	Inches	Inches	Inches
Width	6 Feet	7 Feet	8 Feet
Hydraulic Cylinders (#)	Not Required	Not Required	Not Required
Time required to attach	Approximately 30 Minutes	Approximately 30 Minutes	Approximately 30 Minutes
8" Diameter Double Basket Roller	Optional Attachment	Optional Attachment	Optional Attachment
Length	43 Inches	43 Inches	43 Inches
Width	6 Feet	7 Feet	8 Feet
Hydraulic Cylinders (#)	Not Required	Not Required	Not Required
Time required to attach	Approximately 30 Minutes	Approximately 30 Minutes	Approximately 30 Minutes
12" Diameter Double Basket Roller Pulverizer	Optional Attachment	Optional Attachment	Optional Attachment
Length	51 Inches	51 Inches	51 Inches
Width	6 Feet	7 Feet	8 Feet
Hydraulic Cylinders (#)	Not Required	Not Required	Not Required
Time required to attach	Approximately 30 Minutes	Approximately 30 Minutes	Approximately 30 Minutes

SAFETY & INSTRUCTIONAL DECALS, REFLECTORS AND LIGHTS
ATTENTION! BECOME ALERT! YOUR SAFETY IS INVOLVED!
FAILURE TO FOLLOW THESE INSTRUCTIONS COULD RESULT IN SERIOUS INJURY OR DEATH

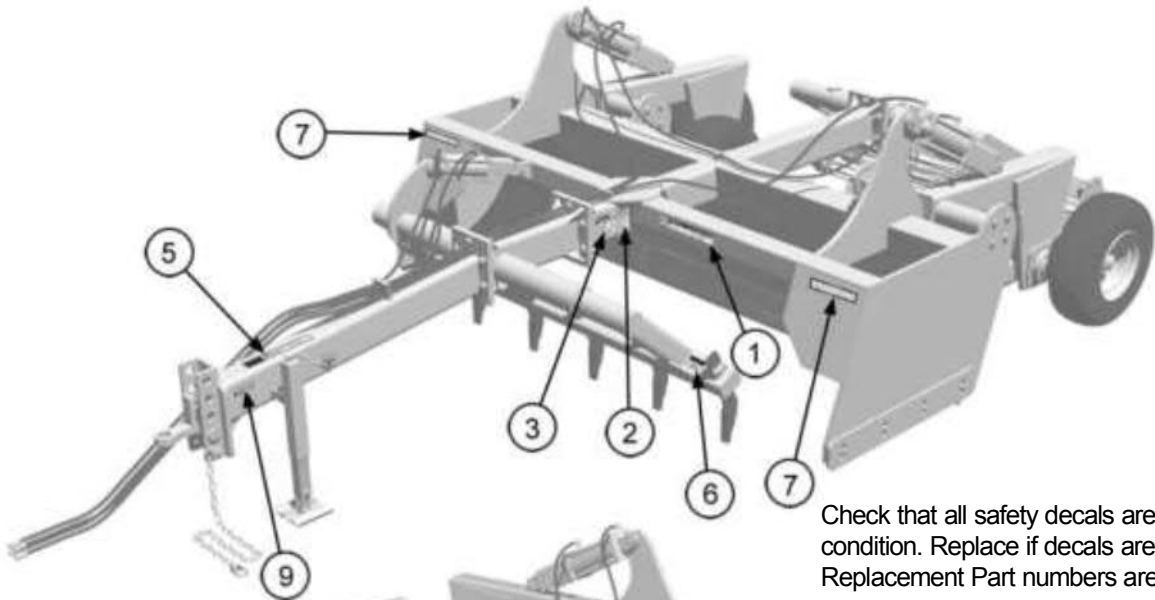

Check that all safety decals are installed and in good condition. Replace if decals are worn or damaged. Replacement Part numbers are listed on Page 4.

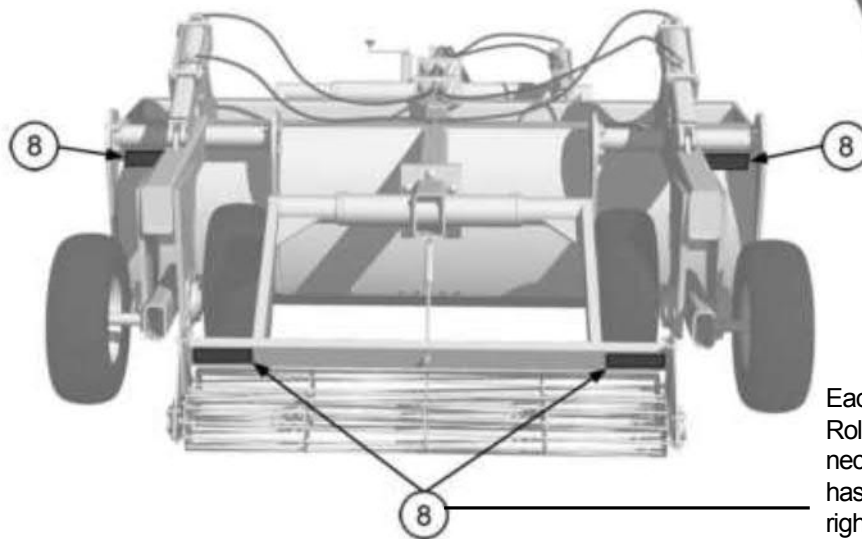
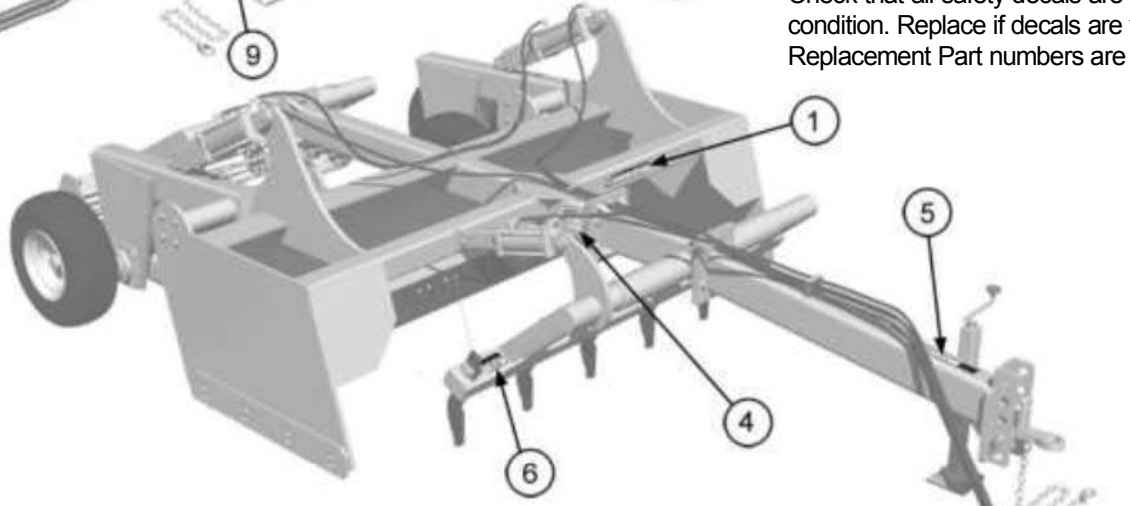

Each optional attachment(Double Rolling Basket shown) that connects at the rear of the LL13 has a red reflective strip(8) on the right and left rear for safety.

3 Safety Decals

SAFETY & INSTRUCTIONAL DECALS, REFLECTORS AND LIGHTS

ATTENTION! BECOME ALERT! YOUR SAFETY IS INVOLVED!

FAILURE TO FOLLOW THESE INSTRUCTIONS COULD RESULT IN SERIOUS INJURY OR DEATH

Check that all safety decals are installed and in good condition. Replace if decals are worn or damaged. Replacement Part numbers are listed here.

DECAL SHEET INCLUDES:
 DECALS 1,2,3,4,5, 6, (2) FRONTIER DECALS,
 (2) LL14 SERIES DECALS FOR EACH
 SPECIFIC MODEL

DECAL SHEET PART NUMBERS FOR EACH
 MODEL:

- | | |
|-----------|--------|
| 5DDP00458 | LL1372 |
| 5DDP00459 | LL1384 |
| 5DDP00460 | LL1396 |



1



2



3



4

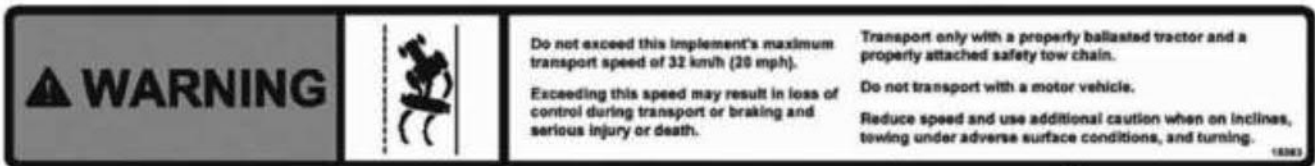

5



6

9 5DDP00205
 Frontier
 Serial Number



7

5DDP00163
 2" x 9" Yellow Reflective Strips



8

5DDP00162
 2" x 9" Red Reflective Strips

Thank you so much for reading.
Please click the “Buy Now!”
button below to download the
complete manual.



After you pay.

You can download the most
perfect and complete manual in
the world immediately.

Our support email:

ebooklibonline@outlook.com