

O P E R A T O R ' S M A N U A L

OFFSET AGRICULTURAL DISKS

| DH5108-DH5110

| DH5112-DH5114-DH5116



Contents

Introduction	1
General Arrangement – Models DH5108 / DH5110 / DH5112	4
General Arrangement – Models DH5114 / DH5116	5
General Information	6
Pre-Delivery Checklist	7
Delivery Checklist	7
After Sale Checklist	8
Daily Checklist	8
Seasonal Checklist	8
Decal Identification and Placement	9
Safety First	10
Attaching the Disc to the Tractor	11
Transporting the Disc	11
Adjusting the Transport Levelling Control Arm	12
Transport and Operating Safety	13
Operating the Disk	
General Operating Guidelines	14
Reposition the Hitch	14
Change the Gang Angles	15
Adjust the Levelling Control Arm	16
Service and Maintenance Safety	17
Lubricate the Disk	18
Check the Oil-Bath Bearings	19
Adjusting the Scrapers	19
Repack and Pre-Load Wheel Hub Bearings	20
Fluid and Fastener Specifications	
Disc Gang Assembly Axles	21
Fastener Torque Values	21
Oil-Bath Bearing Oil	21
Tire and Wheel Service	21
Keep Gang Assemblies Tight	22
Assembly Safety	23
Assemble the Disk	24
Disk Gang Assembly Procedure	32
Detailed Parts Diagrams	33
Hitch and Bridle Assembly (Models DH5108 / DH5110 / DH5112)	34
Hitch and Bridle Assembly (Models DH5114 / DH5116)	35
Frame and Transport Assembly (Models DH5108 / DH5110 / DH5112)	36
Frame and Transport Assembly (Models DH5114 / DH5116)	37
Control Arm Assembly (Models DH5108 / DH5110 / DH5112)	38
Control Arm Assembly (Models DH5114 / DH5116)	39
Gang Bars and Scrapers	40

Gang Assembly (1.625 Axle)	41
Gang Assembly (2.125 Axle)	42
Oil-Bath Bearing Assembly (1.625 Axle)	43
Oil-Bath Bearing Assembly (2.125 Axle)	44
Hydraulic Cylinder (CTD)	45
Hydraulic Cylinder (RAM)	46
Disc Blades	47
6-Bolt Hub	48
Tire and Wheel Assembly	49
Light Kit	50
Decals, Reflectors and Logos	51
Specifications	52
Storage	53

PRODUCT GENERAL ARRANGEMENT AND IDENTIFICATION MODELS DH5108 / DH5110 / DH5112

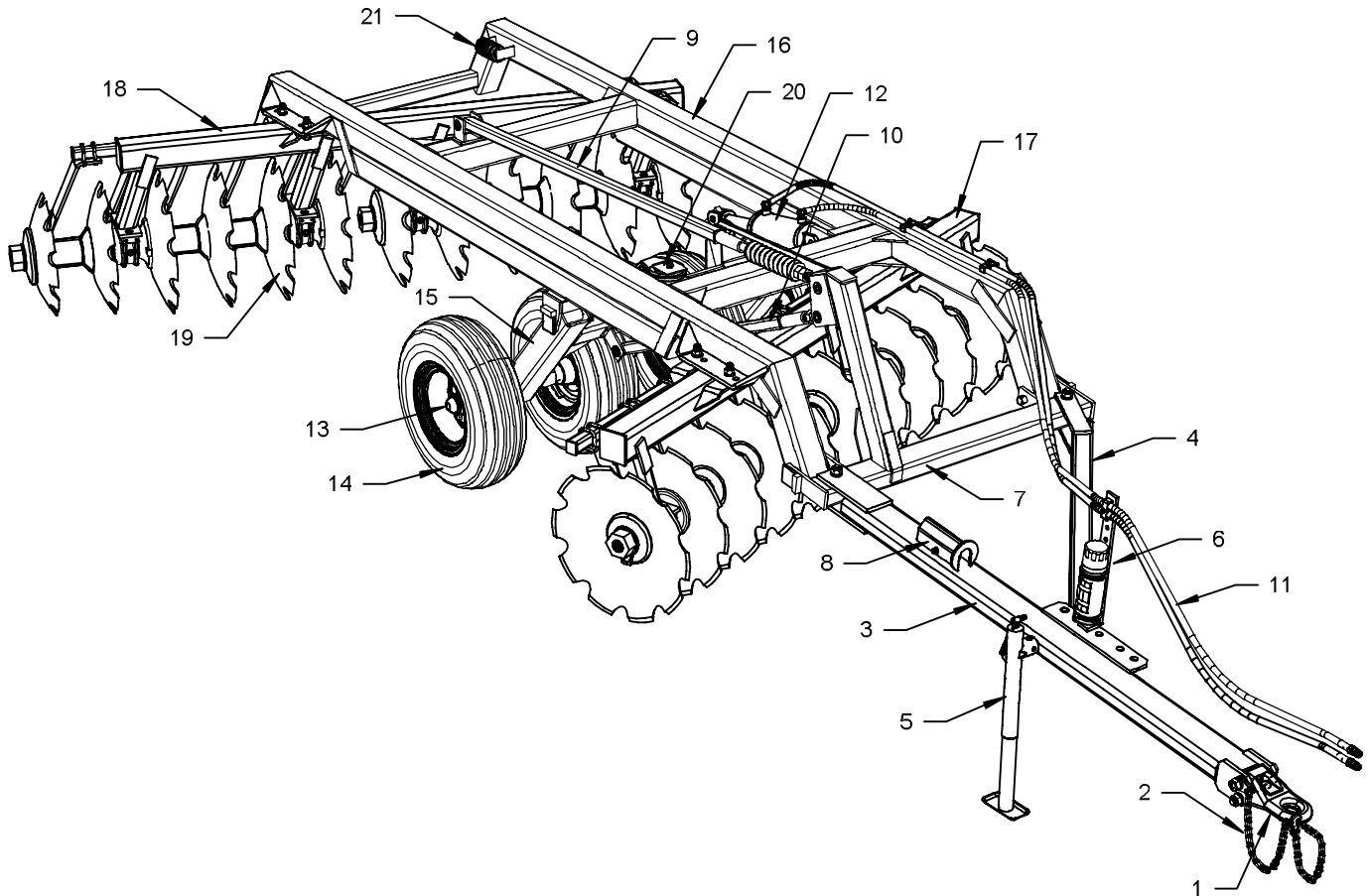

- | | |
|-------------------------------------|-----------------------------------|
| 1 Hitch Tongue | 11 Hydraulic Hose Kit |
| 2 Safety Chain | 12 Hydraulic Cylinder |
| 3 Hitch | 13 Hub Assembly |
| 4 Side Arm | 14 Tire and Wheel Assembly |
| 5 Jack | 15 Transport Assembly |
| 6 Hose Holder & Manual Cannister | 16 Main Frame |
| 7 Bridle | 17 Front Gang Bar c/w Scraper Bar |
| 8 Transport Stay (Storage Location) | 18 Rear Gang Bar c/w Scraper Bar |
| 9 Transport Control Arm | 19 Disc Gang Assembly |
| 10 Leveling Control Arm | 20 Gang Wrenches |
| | 21 Depth Control Segments |

PRODUCT GENERAL ARRANGEMENT AND IDENTIFICATION MODELS DH5114 / DH5116

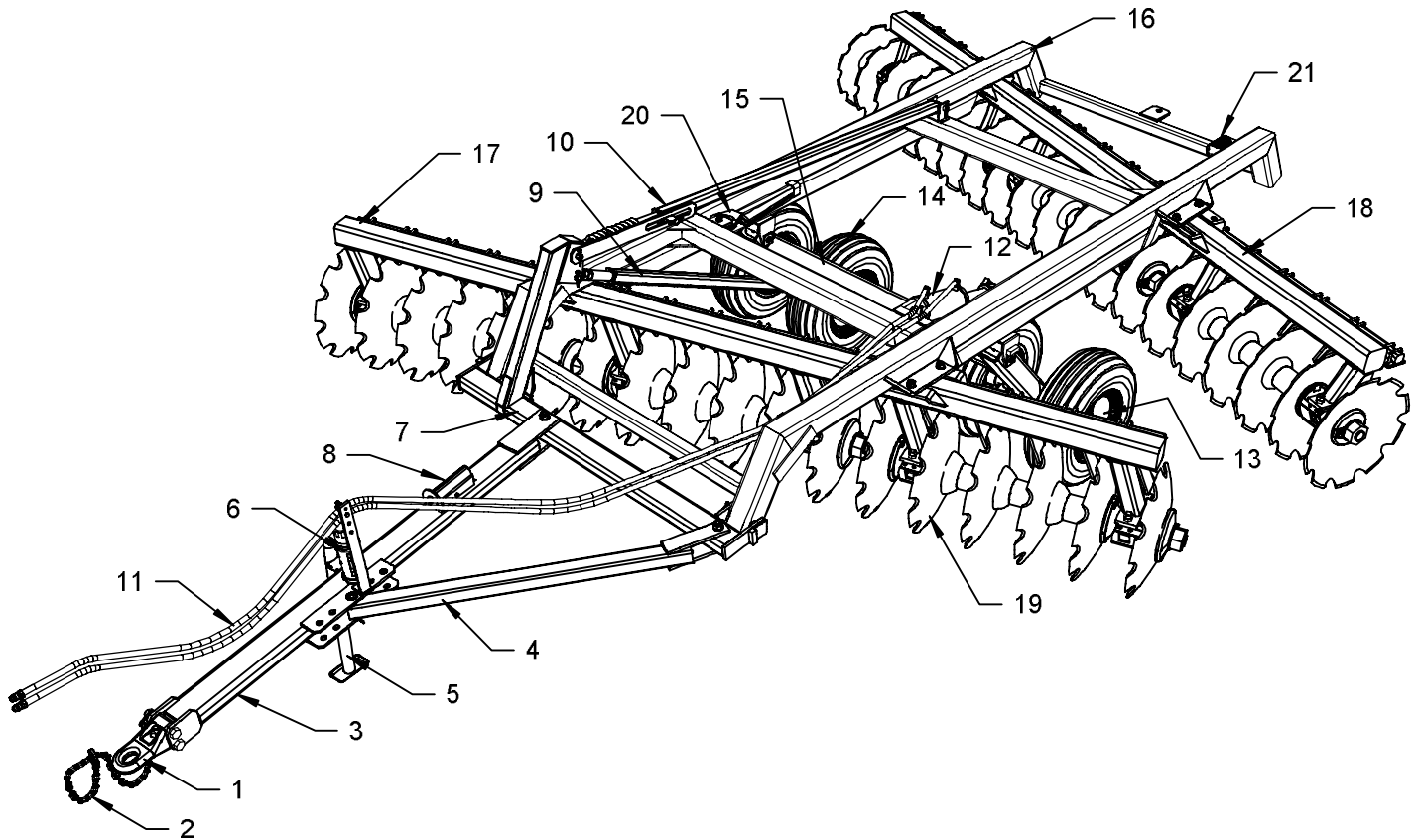

- | | |
|-------------------------------------|-----------------------------------|
| 1 Hitch Tongue | 11 Hydraulic Hose Kit |
| 2 Safety Chain | 12 Hydraulic Cylinder |
| 3 Hitch | 13 Hub Assembly |
| 4 Side Arm | 14 Tire and Wheel Assembly |
| 5 Jack | 15 Transport Assembly |
| 6 Hose Holder & Manual Cannister | 16 Main Frame |
| 7 Bridle | 17 Front Gang Bar c/w Scraper Bar |
| 8 Transport Stay (Storage Location) | 18 Rear Gang Bar c/w Scraper Bar |
| 9 Transport Control Arm | 19 Disc Gang Assembly |
| 10 Leveling Control Arm | 20 Gang Wrenches |
| | 21 Depth Control Segments |

Thank you so much for reading.
Please click the “Buy Now!”
button below to download the
complete manual.



After you pay.

You can download the most
perfect and complete manual in
the world immediately.

Our support email:

ebooklibonline@outlook.com