

O P E R A T O R ' S M A N U A L

HEADER TRANSPORT

Highway Models

HT1224

HT1228

HT1232

HT1238

HT1242

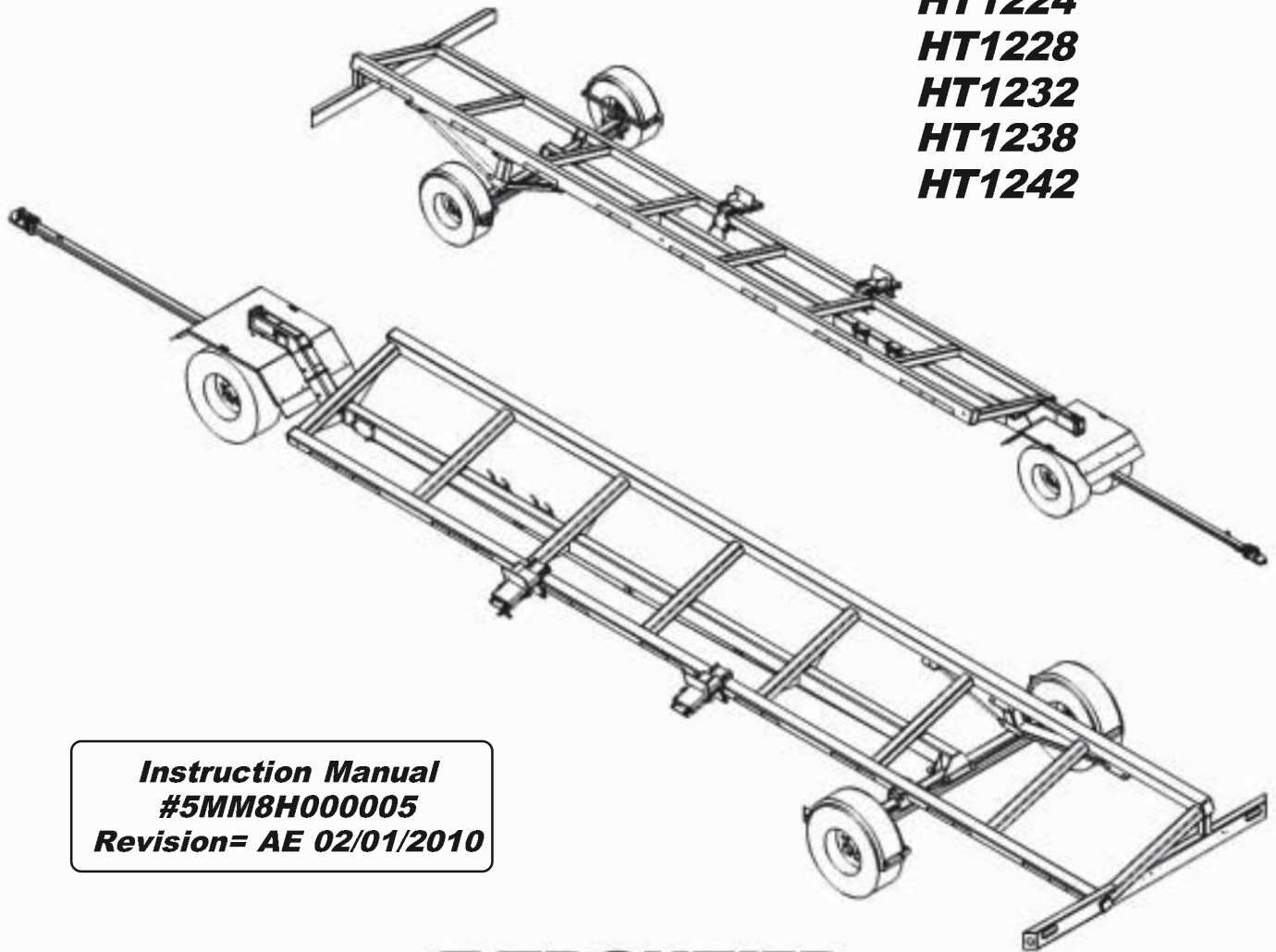

Instruction Manual
#5MM8H000005
Revision= AE 02/01/2010

FRONTIER
EQUIPMENT

TABLE OF CONTENTS

Introduction	ii
Specifications	1-2
Safety Decals	3-4
Safety Rules	5-8
Maintenance Schedule	9
Bolt Torque Requirements	10-11
Standard Tongue Breakdown	12
Long Telescoping Tongue Breakdown	13
Short Telescoping Tongue Breakdown	14
Front Idler Axle & Hub Breakdown	15
Front Idler Suspension Axle & Hub Breakdown	16
Front Brake Axle & Hub Breakdown	17
Front Brake Suspension Axle & Hub Breakdown	18
Bearing Inspection/Lubrication	19
Seal Inspection/Bearing Adjustment	20
Electric Brakes Adjustment	21
Break-Away System	22-23
Adjustable Slider Bracket & Draper	24-25
Header Securement	26
Adjustable Tie-Down / Header Securement	27
Optional Equipment	28
Main Parts Breakdown	29-30
Electrical Diagrams	31-32
GVW Ratings	33
Head Transport Check List	34
Dealer Instructions	35

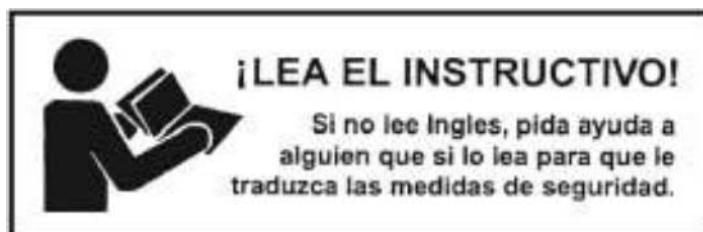

TO THE DEALER:

Assembly and proper installation of this product is the responsibility of the Frontier dealer. Read manual instructions and safety rules. Make sure all items on the Dealer’s Pre-Delivery and Delivery Check Lists in the Owner’s/Operator’s Manual are completed before releasing to the owner.

The dealer must complete the Warranty Registration located on the Frontier website.

TO THE OWNER:

Read this manual before operating your Frontier equipment. The information presented will prepare you to do a better and safer job. Keep this manual handy for ready reference. Require all operators to read this manual carefully and become acquainted with all the adjustment and operating procedures before attempting to operate. Replacement manual can be obtained from your selling dealer.

The equipment you have purchased has been carefully engineered and manufactured to provide dependable and satisfactory use. Like all mechanical products, it will require cleaning and upkeep. Lubricate the unit as specified. Observe all safety information in this manual and safety decals on the equipment.

For service, your authorized Frontier dealer has trained mechanics, genuine Frontier service parts, and the necessary tools and equipment to handle all your needs.

Use only genuine Frontier service parts. Substitute parts will void the warranty and may not meet standards required for safe and satisfactory operations. Record the model number and serial number of your equipment in the spaces provided:

Model: _____ Date of Purchase: _____

Serial Number: (see Safety Decal section for location) _____

Provide this information to your dealer to obtain correct repair parts.

Throughout this manual, the term IMPORTANT is used to indicate that failure to observe can cause damage to equipment. The terms CAUTION, WARNING and DANGER are used in conjunction with the Safety-Alert Symbol (a triangle with an exclamation mark) to indicate the degree of hazard for items of personal safety.



This Safety-Alert Symbol indicates a hazard and means ATTENTION! BECOME ALERT! YOUR SAFETY IS INVOLVED!

▲ DANGER

Indicates an imminently hazardous situation that, if not avoided, will result in death or serious injury.

▲ WARNING

Indicates a potentially hazardous situation that, if not avoided, could result in death or serious injury, and include hazards that are exposed when guards are removed.

▲ CAUTION

Indicates a potentially hazardous situation that, if not avoided, may result in minor or moderate injury.

IMPORTANT

Indicates that failure to observe can cause damage to equipment.

NOTE

Indicates helpful information.

SPECIFICATIONS

Frontier HT12 Series

HT1224 - 24ft, HT1228 - 28ft, HT1232 - 32ft, HT1238 - 38ft & HT1242 - 42ft	
Features	
Intended Transport Mode	Posted roadway speeds Truck tow configuration
Fits Header Equipment	Deere corn, draper and platform HT1224 - 24' & smaller HT1228 - 28' & smaller HT1232 - 32' & smaller HT1238 - 33-38' HT1242 - 39-42'
Frame	Steel, all-welded joints, fixed upper and lower bar
Adjustment Points	Only at mounting brackets
Mounting Brackets	2 adjustable brackets compatible with all Deere headers
Tie Downs	2 ratchet straps standard
Steer Axle	Tricycle, fender standard
Rear Axles	Torsion flex 6000 lb-rated (each), fenders standard HT1224, HT1228, HT1232 - Single rear axle standard HT1232 - Tandem optional (required for transport of 12R and larger corn heads) HT1238, HT1242 - Tandem rear axle standard Tandem rear axles split to eliminate need to remove gauge wheels on draper headers during transport
Hitch	2 5/16 in (5.87 cm) ball w/ safety chains standard 3 in (7.62 cm) pintle eye optional
Tongue	Non-telescoping standard Telescoping optional
Lighting & Marking	7 pole RV plug, highway markings
Brakes	Electric w/ breakaway on all rear axles standard Electric brakes on front tricycle axle optional
Tire Tread	ST225 / 75R15 LRE Import Radial Tires Mounted spare wheel and tire optional

SPECIFICATIONS CON'T

Specifications	
GVWR	HT1224 - 11,200 lbs (5,080 kg) HT1228 - 11,200 lbs (5,080 kg) HT1232 single rear axle - 11,200 lbs (5,080 kg) HT1232 tandem rear axle - 16,800 lbs (7,620 kg) HT1238 - 16,800 lbs (7,620 kg) HT1242 - 16,800 lbs (7,620 kg)
Weight, standard equipment including wheels & tires	HT1224 - 1,915 lbs (869 kg) HT1228 - 2,015 lbs (914 kg) HT1232 single rear axle - 2,235 lbs (1,014 kg) HT1232 tandem rear axle - 2,810 lbs (1,275 kg) HT1238 - 3,175 lbs (1,440 kg) HT1242 - 3,965 lbs (1,798 kg)
Wheels	15 in x 6 in (38.1 cm x 15.2 cm)
Tires	ST225 / 75R15 (Import Radial) 10 ply LRE
Hubs	6 bolt on 5.5 in (14.0 cm) bolt circle
Spindles	3,000 lbs (1,361 kg)
Overall Length	HT1224 - 34.8 ft (10.6 m) HT1228 - 38.8 ft (11.8 m) HT1232 - 42.7 ft (13.0 m) HT1238 - 48.3 ft (14.7m) HT1242 - 52.4 ft (16.0 m)
Tongue Length	7.7 ft (2.3 m)
Wheelbase, to front rear axle	HT1224 - 20.5 ft (6.2 m) HT1228 - 24.5 ft (7.5 m) HT1232 single rear axle - 29.5 ft (9.0 m) HT1232 tandem rear axle - 24.0 ft (7.3 m) HT1238 - 29.5 ft (9.0 m) HT1242 - 34.2 ft (10.4 m)
Tandem Axle Split, center to center	HT1232 tandem rear axle - 5.5 ft (1.7 m) HT1238 - 5.5 ft (1.7 m) HT1242 - 5.5 ft (1.7 m)
Overhang, past back rear axle wheel	HT1224 - 6.5 ft (2.0 m) HT1228 - 6.6 ft (2.0 m) HT1232 - 5.5 ft (1.7 m) HT1238 - 5.6 ft (1.7 m) HT1242 - 5.0 ft (1.5 m)
Overall/Tread Width	102 in (2.6 m)
Adjustment Range, rear of mounting bracket saddle to center of top bar	30 in to 58 in (76 cm to 147 cm)

GENERAL INFORMATION

The purpose of this manual is to assist you in operating and maintaining your Head Transporter. Read it carefully. It furnishes information and instructions that will help you achieve years of dependable performance.

These instructions have been compiled from field experience and engineering data. Some information may be general in nature, due to unknown and varying operating conditions. However, through experience and these instructions, you should be able to develop procedures

suitable to your particular situation.

The illustrations and data used in this manual were current at the time of printing. However, due to possible inline production changes, your machine may vary slightly in detail. We reserve the right to redesign and change the machines as may be necessary without notification.

Throughout this manual, references are made to right and left direction. These are determined by standing behind the tractor facing the direction of forward travel.

Specifications 2

SAFETY & INSTRUCTIONAL DECALS

ATTENTION! BECOME ALERT! YOUR SAFETY IS INVOLVED!

FAILURE TO FOLLOW THESE INSTRUCTIONS COULD RESULT IN SERIOUS INJURY OR DEATH

Replace Decals Immediately If Damaged!

Safety Sign Locations

Types of safety signs and locations on equipment are shown in illustration below. Good safety requires that you familiarize yourself with various safety signs, type of warning, and area or particular function related to that area, that requires your SAFETY AWARENESS.

Ref No.	Part Number	Qty	Description
1	5MMQBP065000	1	FHT - Warning - 2-5/16" & Pintle Coupler
2	5MMQBM065000	1	FHT - Warning -High Speed Transport
3	5MMQBK065000	2	FHT - Warning - Fasten Hdr Securely
4	5MMQBL065000	2	FHT - Warning - Do Not Step
5	5MMQBS065000	1	FHT - Important - Lug Nut
6	5MMQBT065000	1	FHT - Caution - General Info
7	5MMQBN065000	1	FHT - Important - Tongue Info

Please order replacement parts by Part Number and Description.

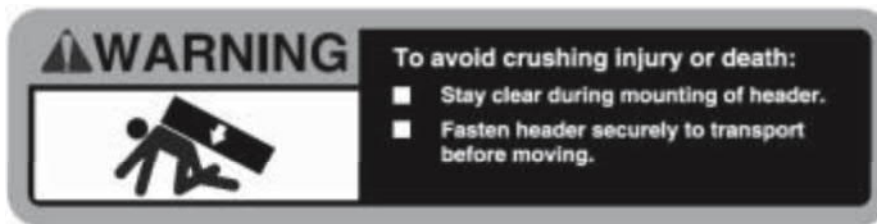

3
Neck - Driver
and
Centered - Bottom Rail

1
Tongue

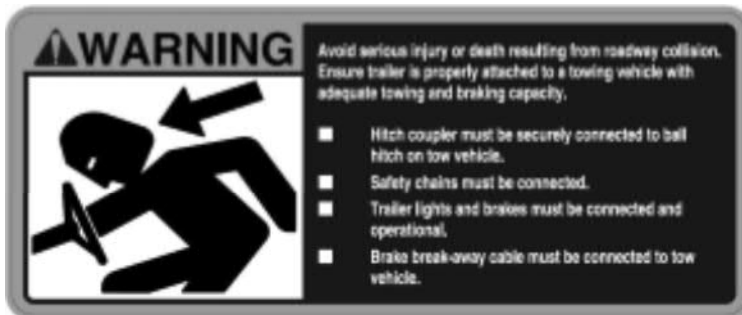
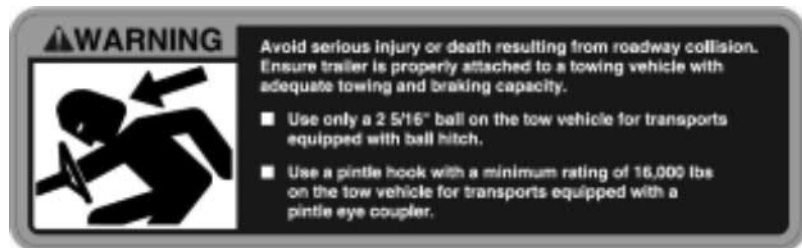

2
Top of Neck

Safety Decals 3

Thank you so much for reading.
Please click the “Buy Now!”
button below to download the
complete manual.



After you pay.

You can download the most
perfect and complete manual in
the world immediately.

Our support email:

ebooklibonline@outlook.com