

OPERATOR'S MANUAL

SNOWBLOWERS

SB1274

SB1280

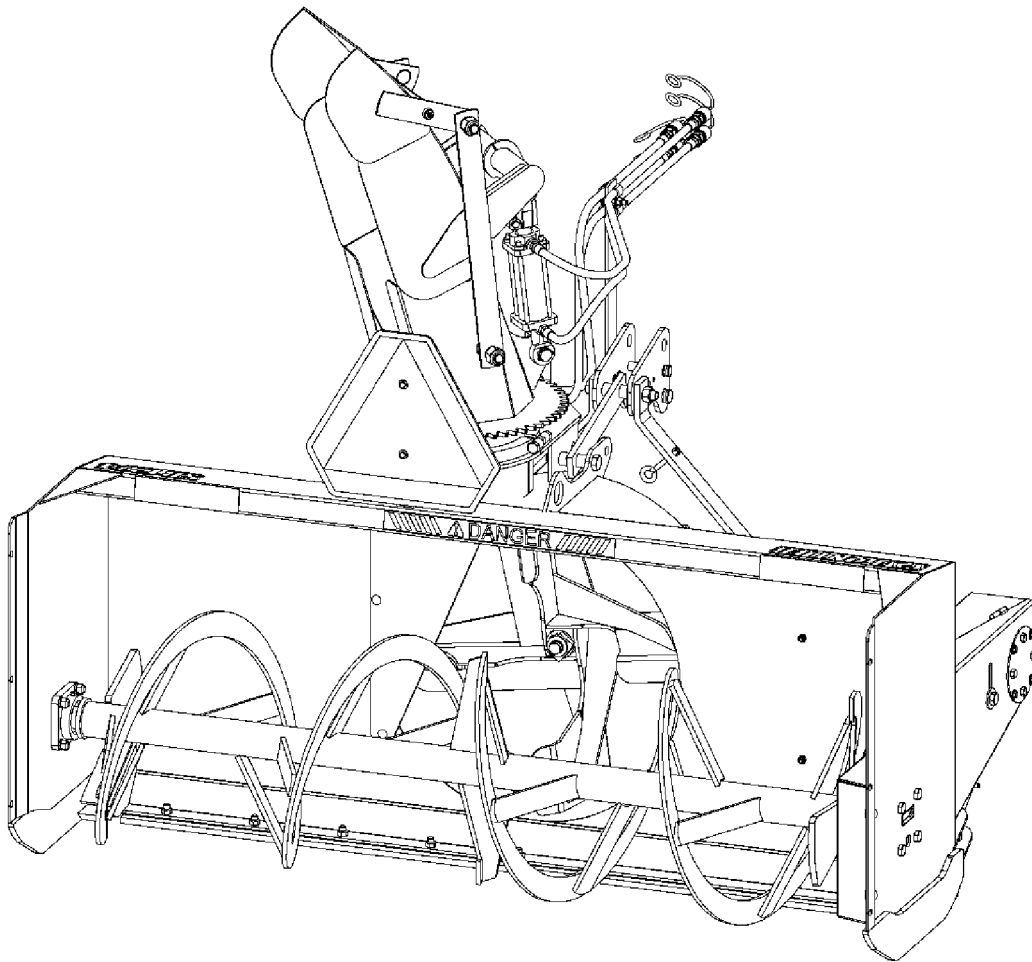

OM0391SB1274-A
03/10

TABLE OF CONTENT

SPECIFICATIONS.....	3
INTRODUCTION – TO THE PURCHASER.....	4
SAFETY PRECAUTIONS	5
General Information.....	5
Before Operation	6
Notice.....	6
The Snowblower.....	6
Before Operation.....	6
Snowblower operation.....	7
The Tractor	7
General Information	7
Maintenance	8
Transporting.....	9
Storage	9
SAFETY DECALS	10
ASSEMBLY.....	12
Snowblower Assembly	12
Installation of the Three Point Hitch	12
Installation of the Chute and the Hydraulic Rotation	14
Installation of the Snowblower with a Three Point Hitch	17
Installation of the Snowblower with Quick Hitch	19
How to Determine Driveline Angles	20
Angles at Each End of Driveline.....	21
Determining Driveline Length.....	21
Installation of the Driveline	23
Removing Snowblower from Tractor	23
OPERATION	24
General Preparation	24
Operating Controls	24
Raising and Lowering the Snowblower.....	24
Work and Travel Speed	24
Drive Shaft Operation	24
Skid Shoes Adjustment	24
Snow Removal Methods	25

TABLE OF CONTENT

MAINTENANCE	26
Maintenance	26
Shearbolts	26
Drive Shaft.....	26
Driveline.....	26
Chain Idler adjustment.....	26
Lubrication.....	27
Driveline Troubleshooting.....	28
PARTS	31
Introduction	31
Snowblowers – SB1274 & SB1280 -Part 1, serial #= XFSB12X090054 & less.....	32
Snowblowers – SB1274 & SB1280 -Part 1, serial #= XFSB12X100001 & up	34
Snowblowers – SB1274 & SB1280 -Part 2,.....	36
Three Point Hitch	38
Chain Idler	39
Three Part Chute – 5RDF0024.....	40
Hydraulic Rotation	41
Gearbox – 5RD662195	42
Driveline – 5RD662194	43
TORQUE SPECIFICATION TABLE	44

SPECIFICATIONS

Features and Specifications	SB1274	SB1280
Working Width	74"	80"
Transport Width	74 1/2"	80 1/2"
Working Height	30"	30"
Length	49" min. – 52" max.	49" min. – 52" max.
Single/Dual Auger	Single	Single
Auger Diameter	20"	20"
Second Auger Diameter (option)	3/8"	3/8"
Auger Flighting Thickness	26"	26"
Impeller Diameter	10 1/2"	10 1/2"
Impeller Width	1 9/16"	1 9/16"
Impeller Shaft Diameter	4	4
Number of Impeller blades	60	60
Roller Chain	10	10
Drive sprocket (# of teeth)	32	32
Driven sprocket (# of teeth)	20"	20"
Chain idler	Twin sprocket	Twin sprocket
Gearbox Manufacturer	Comer	Comer
Gearbox Description	Model T27D	Model T27D
Tractor RPM	540	540
Impeller RPM	540	540
Auger RPM	169	169
PTO Manufacturer	Comer	Comer
PTO Description	50	50
Skid Shoe	Adjustable & replaceable	Adjustable & replaceable
Skid Shoe Material	High Carbon steel	High Carbon steel
End Plate Thickness	.1196"	.1196"
Back Plate Thickness	3/16"	3/16"
Impeller Housing Thickness	3/16" CHT100	3/16" CHT100
Impeller Blade Thickness	5/16"	5/16"
Side Panel Bottom Thickness	1/2"	1/2"
Cutting Edge	High Carbon steel Replaceable & reversible	High Carbon steel Replaceable & reversible
Cutting Edge Dimension	1/2" x 3"	1/2" x 3"
Parking Stand	Standard	Standard
Hitch Category	Cat. 1 & 2	Cat. 1 & 2
Quick Hitch Compatibility	ASABE Compatible	ASABE Compatible
HP Requirements - min-max (hp)	30-80	30-80
Operating Weight (lbs)-hyd. rot. & defl.	1013	1051
Shipping Weight (lbs)	973	1011
Approx. Set-up Time (min.)	35	35
Chute Deflector Adjustment	Hydraulic cylinder (2" x 4") including hoses and tips	Hydraulic cylinder (2" x 4") including hoses and tips
Chute Rotation (standard)	Hydraulic with motor	Hydraulic with motor
Chute option	3 part with hydraulic deflector	3 part with hydraulic deflector

Thank you so much for reading.
Please click the “Buy Now!”
button below to download the
complete manual.



After you pay.

You can download the most
perfect and complete manual in
the world immediately.

Our support email:

ebooklibonline@outlook.com