

OPERATOR'S MANUAL

# ROTARY BROOM

SW2160 | SW2172 | SW2184

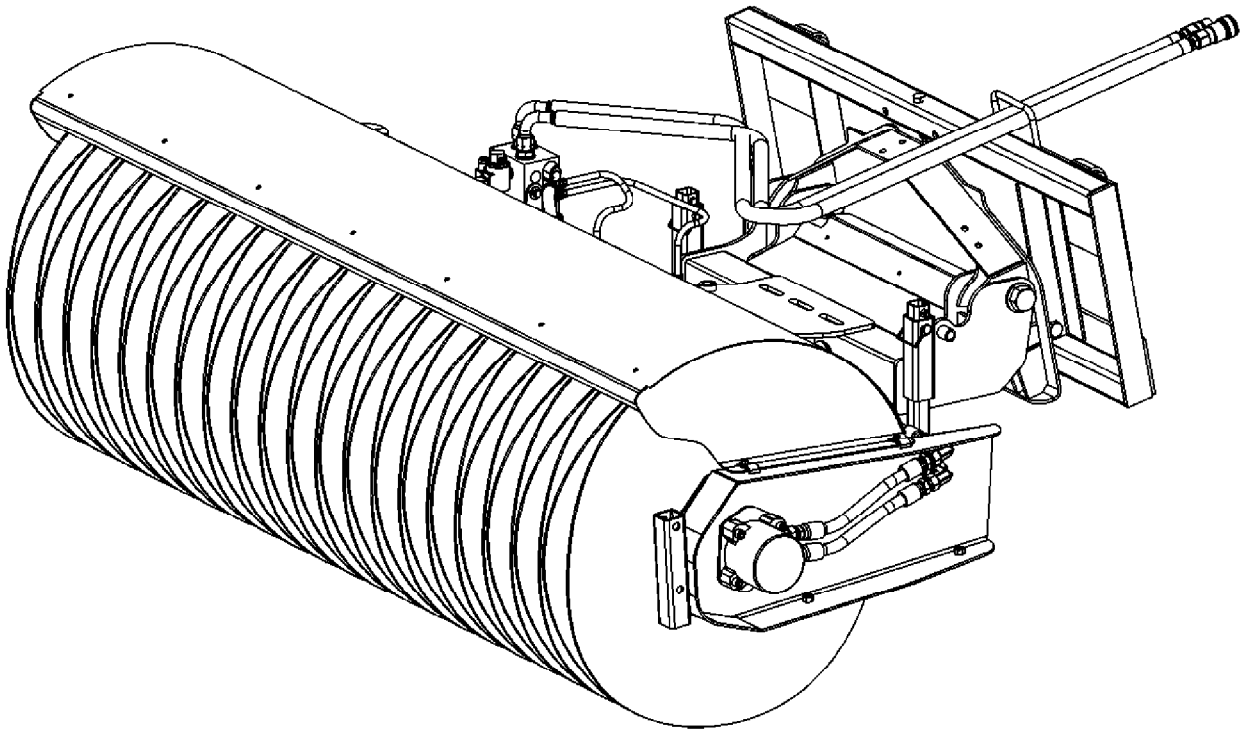

OM 0402BR-A

01/11

---

# TABLE OF CONTENT

---

SPECIFICATIONS.....	3
INTRODUCTION – TO THE PURCHASER.....	4
SAFETY PRECAUTIONS .....	5-12
Before Operation.....	5
Notice.....	6
The Rotary Broom.....	6
Before Operation .....	6
Broom Operation .....	7
The Tractor.....	8
General Information.....	8
Operating the Tractor .....	8
During Operation .....	9
Roll-Over Protective Structure (ROPS) (if equipped) .....	9
Additional Safety Equipment .....	9
Maintenance .....	10
Transport .....	11
Storage .....	11
DECALS .....	12
ASSEMBLY .....	13-33
Broom Assembly .....	13
Installation of Broom on Front Loader .....	13
Installation of the Hydraulic Hoses .....	14
Installation of Electrical Wiring – Tractor With Cab.....	15-19
Installation of Electrical Wiring – Open Station Tractor .....	20-25
Installation of the Switchbox 5RD669285 - Option .....	26
Installation of Dust Deflector – 5RDF0030-0031-0032 .....	27
Installation Lawn Dethatching Wheel Support – 5RDF0034.....	28-29
Installation Lawn Dethatching Wheel kit – 5RDF0033.....	30
Installation of the Cooling Unit – 5RDF0036.....	31-32
Removing the Broom from the Front Loader .....	33

---

# TABLE OF CONTENT

---

OPERATION.....	34-37
Optimum Performances .....	34
General Preparation.....	34
Operating Controls.....	34
Hydraulic Angling Adjustment .....	34
Ground Pressure Adjustment .....	35-36
General Sweeping.....	36
Lawn Dethatching & Lawn Raking .....	37
MAINTENANCE.....	38-46
Maintenance .....	38
Hydraulic Oil .....	38
Storage.....	38
Brush Replacement.....	41-40
Compression Springs .....	40
Lubrication .....	41
Verification .....	41
Troubleshooting .....	42-44
Hydraulic Diagram .....	45
Electric Diagram.....	46
TORQUE SPECIFICATION TABLE.....	47-49

## SPECIFICATION

Features and Specifications	SW2160	SW2172	SW2184
Width – in (cm)	72 (183)	84 (213)	96 (244)
Working width, straight – in (cm)	60 (152)	72 (183)	84 (213)
Working width at maximum angle – in (cm)	55 (140)	66 (168)	77 (196)
Working Height – in (cm)	34 (87)	34 (87)	34 (87)
Length – in (cm)	69 (175)	69 (175)	69 (175)
Recommended Flow – GPM	12 to 22	12 to 22	12 to 22
Recommended Pressure- PSI	2100 to 3600	2100 to 3600	2100 to 3600
Number of wafer	34	39	46
Type of brush	"Z"	"Z"	"Z"
100% polypropyl. Brush	Standard	Standard	Standard
Polypropyl./steel (50/50)	Option	Option	Option
Brush diameter – in (cm)	32 (81)	32 (81)	32 (81)
Brush speed with Hydraulic Pump HP series -rpm	160	160 – HP2025 200 – HP2134	200
Hydraulic Angling	Standard	Standard	Standard
Angling Range	23°-0°-23°	23°-0°-23°	23°-0°-23°
Shear Pin	Standard	Standard	Standard
Loader Compatibility	Current JD 300 Series Loader Carriers	Current JD 300 & 400 Series Loader Carriers	Current JD 400 Series Loader Carriers
Dust Deflector	Option	Option	Option
Lawn Dethatching Wheel kit	Option	Option	Option
Parking Stand	Standard	Standard	Standard
Approx. shipping weight - lbs (kg)	1177 (314)	1197 (338)	1237 (363)
Brush Cover Thickness – ga (in)	14 – 0.0747	14 – 0.0747	14 – 0.0747
Side Panel Thickness – in (mm)	3/16 (5)	3/16 (5)	3/16 (5)
Broom drive	Hydraulic Motor 375 cc/rev.	Hydraulic Motor 375 cc/rev.	Hydraulic Motor 375 cc/rev.
Relief Valve Protection	Standard	Standard	Standard
Main hydraulic Hoses – in (mm)	3/4 (76)	3/4 (76)	3/4 (76)
Cooling Unit	Option	Option	Option
Dust Suppression system	Option	Option	Option
Rear Spraying Support	Standard	Standard	Standard
Hydraulic Power Pack compatibility	HP2025	HP2025 or HP2134	HP2134

Assembly time: 2-3 hours (including the hydraulic pump).

Thank you so much for reading.  
Please click the “Buy Now!”  
button below to download the  
complete manual.



After you pay.

You can download the most  
perfect and complete manual in  
the world immediately.

Our support email:

[ebooklibonline@outlook.com](mailto:ebooklibonline@outlook.com)