

OPERATOR'S MANUAL

BOX BLADES

BB5060

BB5048L

BB5072

BB5060L

BB5084

BB5096

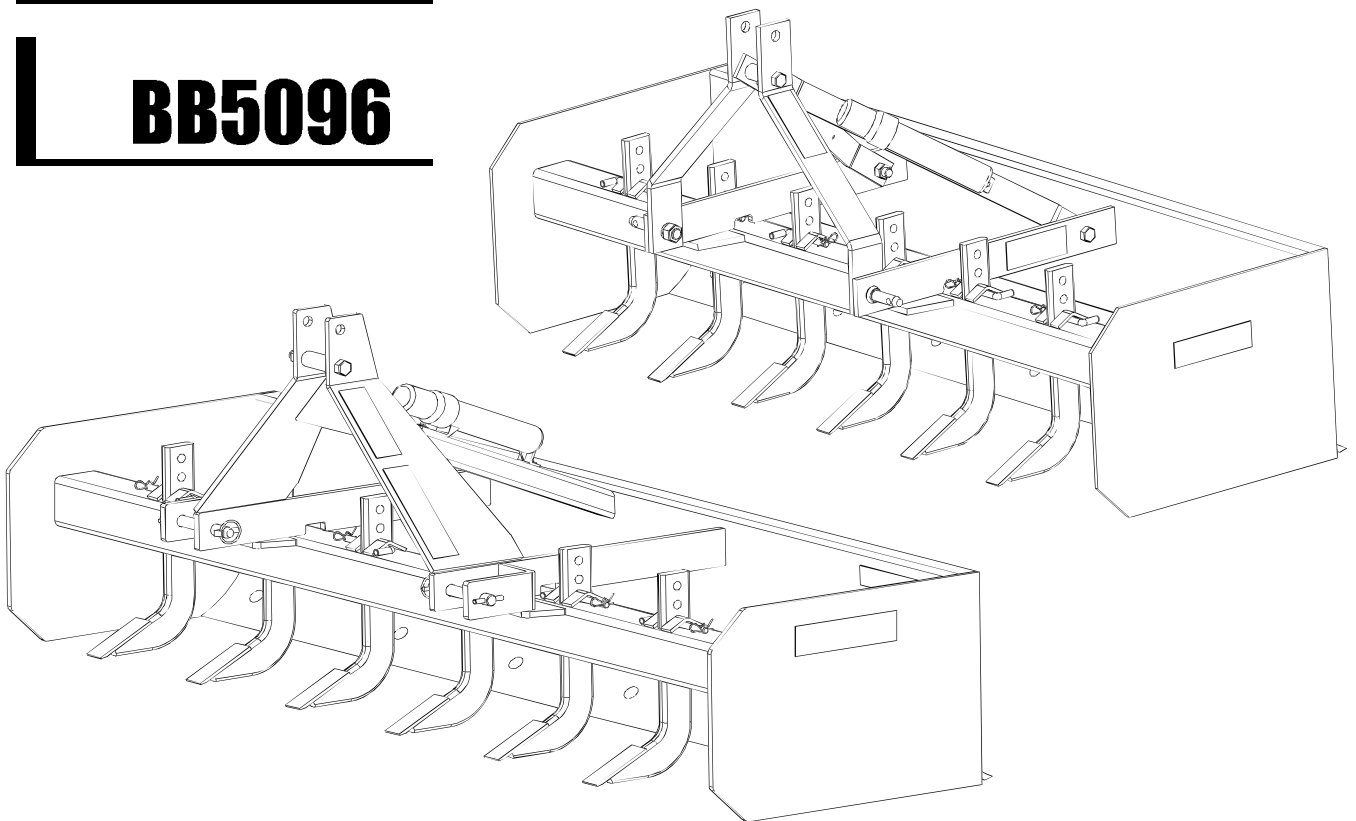

FRONTIER
EQUIPMENT™

TO THE DEALER:

Assembly and proper installation of this product is the responsibility of the Frontier dealer. Read manual instructions and safety rules. Make sure all items on the Preparation Check List in the Operator's Manual are completed before releasing equipment to the owner.

TO THE OWNER:

Read this manual before operating your Frontier equipment. Keep this manual handy for ready reference. Require all operators to read this manual carefully and become acquainted with all adjustments and operating procedures before attempting to operate the equipment. Replacement manuals can be obtained from your selling dealer.

The equipment you have purchased has been carefully engineered and manufactured to provide dependable and satisfactory use. Like all mechanical products, it will require cleaning and upkeep. Lubricate the unit as specified. Please observe all safety information in this manual and safety decals on the equipment.

For service, your authorized Frontier dealer has trained mechanics, genuine Frontier service parts, and the necessary tools and equipment to handle all of your service needs.

Use only genuine Frontier service parts. Substitute parts will void the warranty and may not meet standards required for safe and satisfactory operation. Record the model number and serial number of your equipment in the spaces provided:

Model _____ **Date of Purchase** _____

Serial Number: (see Safety Decal section for location) _____

Provide this information to your dealer to obtain correct repair parts.

Throughout this manual, the term **IMPORTANT** is used to indicate that failure to observe procedures can cause damage to equipment. The terms **CAUTION**, **WARNING** and **DANGER** are used in conjunction with the Safety-Alert Symbol, (a triangle with an exclamation mark), to indicate the degree of hazard for items of personal safety.



This is the safety alert symbol. it is used to alert you to potential personal injury hazards. Obey all safety messages that follow this symbol to avoid possible injury or death.



Indicates an imminently hazardous situation that, if not avoided, will result in death or serious injury.



Indicates a hazardous situation which, if not avoided, could result in death or serious injury.



Indicates a potentially hazardous situation that, if not avoided, may result in minor or moderate injury.

IMPORTANT Is used to address practices not related to personal injury.

NOTE Indicates helpful information.

2 Introduction

TABLE OF CONTENTS

INTRODUCTION	2
GENERAL INFORMATION	3
SPECIFICATIONS	4
SAFETY RULES	5-6
DEALER CHECK LISTS	7
SAFETY DECALS	8-9
OPERATION	10-12
OWNER SERVICE	12-13
PARTS LIST	14-15
BOLT TORQUE CHART	16
BOLT SIZE CHART & ABBREVIATIONS	17

All information, illustrations and specifications in this manual are based on the latest information available at the time of publication. The right is reserved to make changes at any time without notice.

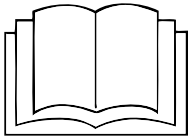

This Operator's Manual should be regarded as part of the machine. Suppliers of both new and second-hand machines must make sure that this manual is provided with the machine.

GENERAL INFORMATION

The purpose of this manual is to assist you in operating and maintaining your Box Blade. Read it carefully. It furnishes information and instructions that will help you achieve years of dependable performance.

These instructions have been compiled from extensive field experience and engineering data. Some information may be general in nature, due to unknown and varying operating conditions. However, through experience and these instructions, you should be able to develop procedures suitable to your particular situation.

The illustrations and data used in this manual were current at the time of printing. However, due to possible inline production changes, your machine may vary slightly in detail. We reserve the right to redesign and change the machines as may be necessary without notification.

Throughout this manual, references are made to right and left directions. These are determined by standing behind the tractor facing the direction of forward travel.

Thank you so much for reading.
Please click the “Buy Now!”
button below to download the
complete manual.



After you pay.

You can download the most
perfect and complete manual in
the world immediately.

Our support email:

ebooklibonline@outlook.com