

OPERATOR'S MANUAL

# DISK HARROWS

**DH1276**

**DH1280**

**DH1296**



**FRONTIER**  
EQUIPMENT

# TABLE OF CONTENTS

|  |         |
|--|---------|
| INTRODUCTION . . . . .                         | ii      |
| SPECIFICATIONS / GENERAL INFORMATION . . . . . | 1       |
| SAFETY DECALS . . . . .                        | 2 - 3   |
| SAFETY RULES . . . . .                         | 4 - 6   |
| DEALER INSTRUCTIONS . . . . .                  | 7       |
| OPERATION . . . . .                            | 8 - 9   |
| TROUBLE SHOOTING. . . . .                      | 10      |
| OWNER SERVICE . . . . .                        | 11      |
| PARTS CATALOG . . . . .                        | 12 - 14 |
| OPTIONAL EQUIPMENT . . . . .                   | 15 - 18 |
| BOLT SIZE AND BOLT TORQUE CHART . . . . .      | 19      |
| WARRANTY . . . . .                             | 20      |
| WARRANTY FOR PARTS . . . . .                   | 21      |
| NOTES . . . . .                                | 22      |

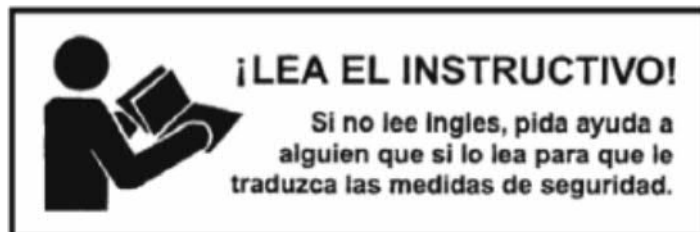

## SPECIFICATIONS

|                              | DH1276  | DH1280  | DH1280  | DH1296  | DH1296  |
|------------------------------|---|---|---|---|---|
| 3-Point Hitch                | Category 1<br>(iMatch Compatible)   | Category 1<br>(iMatch Compatible)   | Category 1<br>(iMatch Compatible)   | Category 1<br>(iMatch Compatible)   | Category 1<br>(iMatch Compatible)   |
| Working Width                | 76"   | 80"   | 80"   | 96"   | 96"   |
| Blade Spacing                | 9"  | 7.5"  | 9" Front, 7.5" Rear   | 9"  | 7.5"  |
| Tractor HP (MAX)             | 55 HP   | 55 HP   | 55 HP   | 55 HP   | 55 HP   |
| Shipping Weight              | 935 lbs.  | 978 lbs.  | 969 lbs.  | 1040 lbs.   | 1066 lbs.   |
| Approximate Operating Weight | 890 lbs.  | 942 lbs.  | 915 lbs.  | 968 lbs.  | 1038 lbs.   |
| Number of Blades             | 16  | 20  | 18  | 20  | 24  |
| Blade Size                   | 20" diameter  | 20" diameter  | 20" diameter  | 20" diameter  | 20" diameter  |
| Blade Thickness              | 3.5mm(.138)   | 3.5mm(.138)   | 3.5mm(.138)   | 3.5mm(.138)   | 3.5mm(.138)   |
| Blade Type                   | 1. Notched (front) /<br>Notched (Rear)<br>2. Smooth (Front) /<br>Smooth (Rear)<br>3. Notched (Front) /<br>Smooth (Rear) | 1. Notched (front) /<br>Notched (Rear)<br>2. Smooth (Front) /<br>Smooth (Rear)<br>3. Notched (Front) /<br>Smooth (Rear) | 1. Notched (front) /<br>Notched (Rear)<br>2. Smooth (Front) /<br>Smooth (Rear)<br>3. Notched (Front) /<br>Smooth (Rear) | 1. Notched (front) /<br>Notched (Rear)<br>2. Smooth (Front) /<br>Smooth (Rear)<br>3. Notched (Front) /<br>Smooth (Rear) | 1. Notched (front) /<br>Notched (Rear)<br>2. Smooth (Front) /<br>Smooth (Rear)<br>3. Notched (Front) /<br>Smooth (Rear) |
| Frame Tubing                 | 3" square   | 3" square   | 3" square   | 3" square   | 3" square   |
| Gang Tubing                  | 3" square   | 3" square   | 3" square   | 3" square   | 3" square   |
| Bearing Hanger               | High strength 3" channel steel hangers with 5/8" bolts and plate  | High strength 3" channel steel hangers with 5/8" bolts and plate  | High strength 3" channel steel hangers with 5/8" bolts and plate  | High strength 3" channel steel hangers with 5/8" bolts and plate  | High strength 3" channel steel hangers with 5/8" bolts and plate  |
| Bearing Type                 | Self aligning sealed ball bearing in pillow block   | Self aligning sealed ball bearing in pillow block   | Self aligning sealed ball bearing in pillow block   | Self aligning sealed ball bearing in pillow block   | Self aligning sealed ball bearing in pillow block   |
| Gang Axle                    | 1 1/8" square   | 1 1/8" square   | 1 1/8" square   | 1 1/8" square   | 1 1/8" square   |
| Front Gang Angles            | 13, 16,19,23  | 13, 16,19,23  | 13, 16,19,23  | 13, 16,19,23  | 13, 16,19,23  |
| Rear Gang Angles             | 8, 11, 19, 23   | 8, 11, 19, 23   | 8, 11, 19, 23   | 8, 11, 19, 23   | 8, 11, 19, 23   |
| Apprx.AssemblyTime           | 15 Min.   | 15 Min.   | 15 Min.   | 15 Min.   | 15 Min.   |

## GENERAL INFORMATION

The purpose of this manual is to assist you in operating and maintaining your Disc Harrow. Read it carefully. It furnishes information and instructions that will help you achieve years of dependable performance.

These instructions have been compiled from field experience and engineering data. Some information may be general in nature, due to unknown and varying operating conditions. However, through experience and these instructions, you should be able to develop procedures suitable to

your particular situation.

The illustrations and data used in this manual were current at the time of printing. However, due to possible inline production changes, your machine may vary slightly in detail. We reserve the right to redesign and change the machines as may be necessary without notification.

Throughout this manual, references are made to right and left direction. These are determined by standing behind the tractor facing the direction of forward travel.

# SAFETY & INSTRUCTIONAL DECALS

**ATTENTION! BECOME ALERT! YOUR SAFETY IS INVOLVED!**

**FAILURE TO FOLLOW THESE INSTRUCTIONS COULD RESULT IN SERIOUS INJURY OR DEATH**  
**Replace Decals Immediately If Damaged!**

|  |   |                  |
|--|---|------------------|
|   |  | <b>⚠ WARNING</b> |
|   |  |                  |
| <b>CRUSHING AND PINCHING HAZARD</b>  |   |                  |
| <ul style="list-style-type: none"> <li>• Be extremely careful handling various parts of the machine. They are extremely heavy and hands, fingers, feet and other body parts could be crushed or pinched between tractor and implement.</li> <li>• Operate tractor controls from tractor seat only.</li> <li>• Do not stand between tractor and implement when tractor is in gear.</li> <li>• Make sure parking brake is engaged before going between tractor and implement.</li> <li>• Stand clear of machine when in operation or being raised or lowered.</li> </ul> |   |                  |
| <small>15194A</small>  |   |                  |

①

5TL15194A

Check that all safety decals are installed and in good condition. Replace if decals are worn or damaged. Replacement Part numbers are listed here.

|   |                  |
|---|------------------|
|    | <b>⚠ WARNING</b> |
|    |                  |
| <b>FALLING BLADE HAZARD</b>   |                  |
| <ul style="list-style-type: none"> <li>• Can cause serious injury or death.</li> <li>• Keep hands and feet from under raised blade.</li> <li>• Always put disc in the lowered position and chock gangs to prevent rolling when disconnecting disc gangs for maintenance or repair.</li> </ul> |                  |
| <small>15194B</small>   |                  |

②

5TL15194B

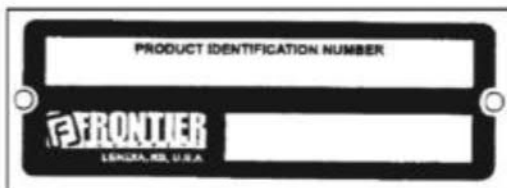
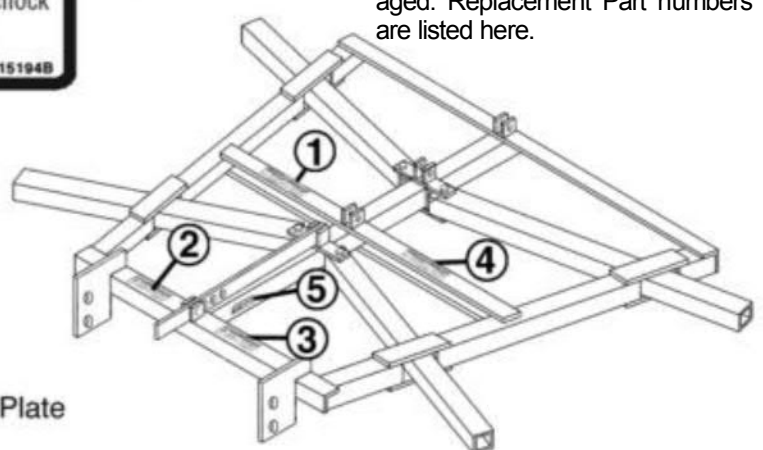

⑤

Serial Number Plate



|  |                  |
|--|------------------|
|   | <b>⚠ WARNING</b> |
|  |                  |
| <b>TO PREVENT SERIOUS INJURY OR DEATH:</b>   |                  |
| <ul style="list-style-type: none"> <li>• Avoid unsafe operation and maintenance. Do not operate or work on this machine without reading and understanding the operator's manual.</li> <li>• If manual is lost, contact your dealer.</li> </ul> |                  |
| <small>15194C</small>  |                  |

③

5TL15194C

5TL15194D

④

|   |                  |
|---|------------------|
|    | <b>⚠ WARNING</b> |
|    |                  |
| <ul style="list-style-type: none"> <li>• DO NOT allow others to ride on the machine or tractor.</li> <li>• Park or block disc so it will not roll when disconnecting from tractor drawbar.</li> <li>• Never go underneath equipment (lowered to the ground or raised) unless it is properly blocked and secured.</li> <li>• Never place any part of the body underneath equipment or between movable parts even when the engine has been turned off.</li> <li>• Be sure that everyone is standing clear before operating the machine.</li> <li>• DO NOT operate or transport at high speeds.</li> <li>• DO NOT operate or transport on steep slopes.</li> </ul> |                  |
| <small>15194D</small>   |                  |

# SAFETY REFLECTOR DECALS

**ATTENTION! BECOME ALERT! YOUR SAFETY IS INVOLVED!**

**FAILURE TO FOLLOW THESE INSTRUCTIONS COULD RESULT IN SERIOUS INJURY OR DEATH**

**Replace Decals Immediately If Damaged!**

## **DH1276 and DH1280 Reflector Decals**

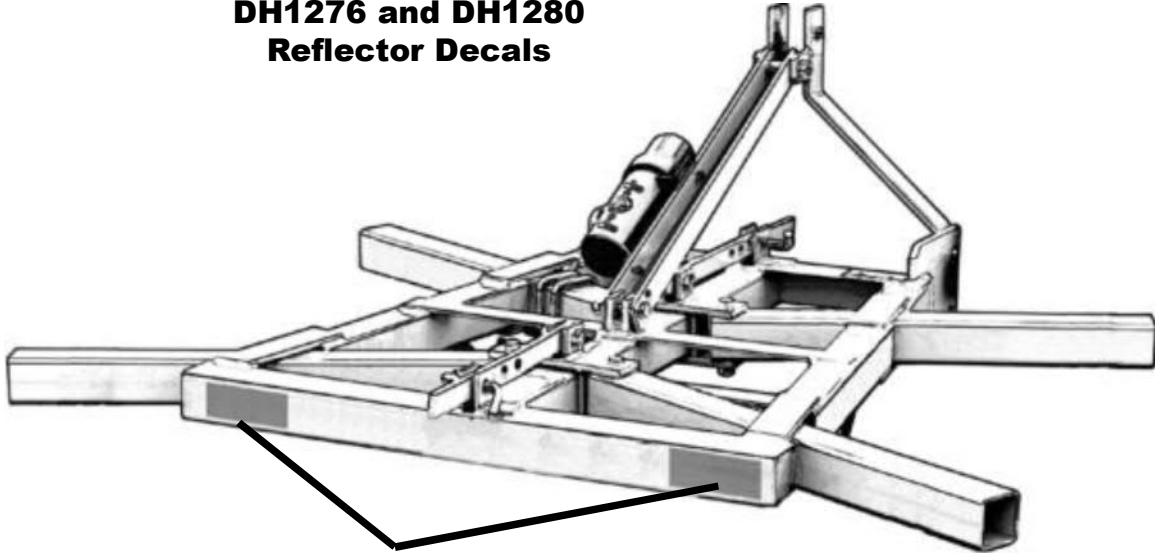

4 1/2" RED REFLECTORS

5TL15240

Check that all reflector decals are installed and in good condition. Replace if decals are worn or damaged.

## **DH1296 Reflector Decals**

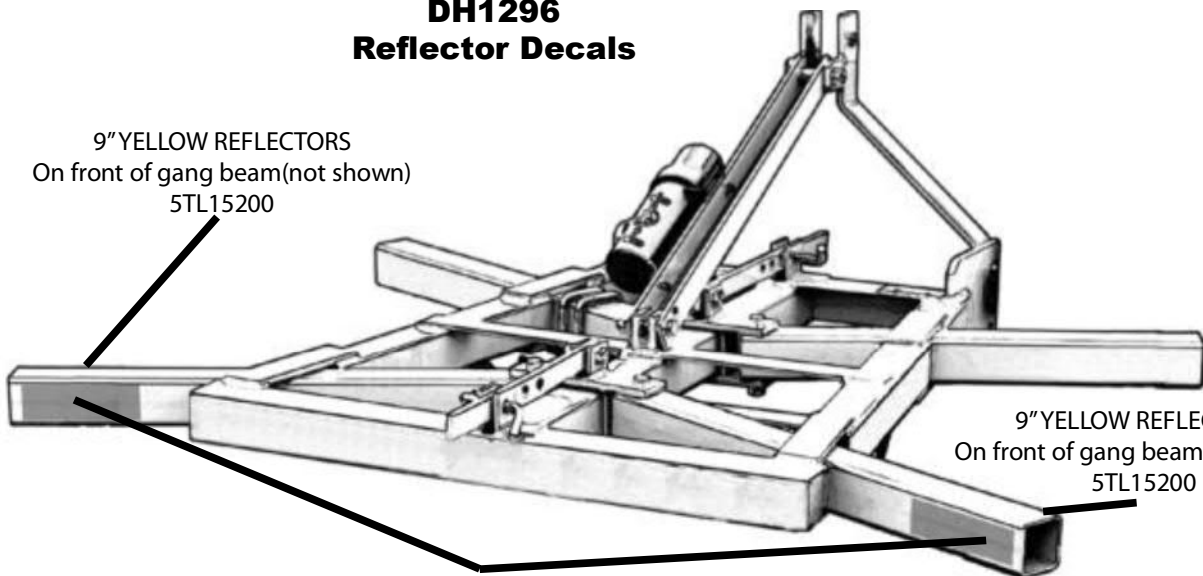

9" YELLOW REFLECTORS  
On front of gang beam(not shown)  
5TL15200

9" YELLOW REFLECTORS  
On front of gang beam(not shown)  
5TL15200

9" RED REFLECTORS

5TL15199

Check that all reflector decals are installed and in good condition. Replace if decals are worn or damaged.



# SAFETY RULES



ATTENTION! BECOME ALERT! YOUR SAFETY IS INVOLVED!

Safety is a primary concern in the design and manufacture of our products. Unfortunately, our efforts to provide safe equipment can be wiped out by an operator's single careless act.

In addition to the design and configuration of equipment, hazard control and accident prevention are dependent upon the awareness, concern, judgement, and proper training of personnel involved in the operation, transport, maintenance and storage of equipment.

It has been said "The best safety device is an informed, careful operator." We ask you to be that kind of operator.

## TRAINING

- Safety instructions are important! Read all attachment and power unit manuals; follow all safety rules and safety decal information. (Replacement manuals are available from selling dealer.) Failure to follow instructions or safety rules can result in serious injury or death.
- If you do not understand any part of this manual and need assistance, see your dealer.
- Operators must be instructed in and be capable of the safe operation of the equipment, its attachments, and all controls. Do not allow anyone to operate this equipment without proper instructions.
- Never allow children or untrained persons to operate equipment.
- Train all new personnel and review instruction's frequently with existing workers. A person who has not read and understood all operating and safety instructions is not qualified to operate the machine. An untrained operator exposes himself and bystanders to possible serious injury or death.

## PREPARATION

- Always wear relatively tight and belted clothing to

avoid getting caught in moving parts. Wear sturdy, rough-soled work shoes and protective equipment for eyes, hair, hands, hearing, and head; and respirator or filter mask where appropriate.

- Make sure attachment is properly secured, adjusted, and in good operating condition.
- Power unit must be equipped with ROPS or ROPS cab and seat belt. Keep seat belt securely fastened. Falling off power unit can result in death from being run over or crushed. Keep foldable ROPS system in "locked up" position at all times.
- A minimum 20% of tractor and equipment weight must be on the tractor front wheels when attachments are in transport position. Without this weight, tractor could tip over, causing personal injury or death. The weight may be attained with a loader, front wheel weights, ballast in tires or front tractor weights. Weigh the tractor and equipment. Do not estimate.

## TRANSPORTATION

- Always comply with all state and local laws governing highway safety and lighting and marking requirements.
- Never allow riders on power unit or attachment.
- Do not operate or transport on steep slopes.
- Use extreme care and reduce ground speed on slopes and rough terrain.
- Do not operate or transport equipment while under the influence of alcohol or drugs. Consult your doctor about operating this machine while taking prescription medications.

## OPERATION

- Never go underneath equipment (lowered to the ground or raised) unless it is properly

Thank you so much for reading.  
Please click the “Buy Now!”  
button below to download the  
complete manual.



After you pay.

You can download the most  
perfect and complete manual in  
the world immediately.

Our support email:

[ebooklibonline@outlook.com](mailto:ebooklibonline@outlook.com)