

O P E R A T O R ' S M A N U A L

GROOMING MOWERS

FM1012R

FM1015R

FM1017R

15-Digit Serial Numbers prior to WDFM10XXR239170
Revision Effective 2/2006

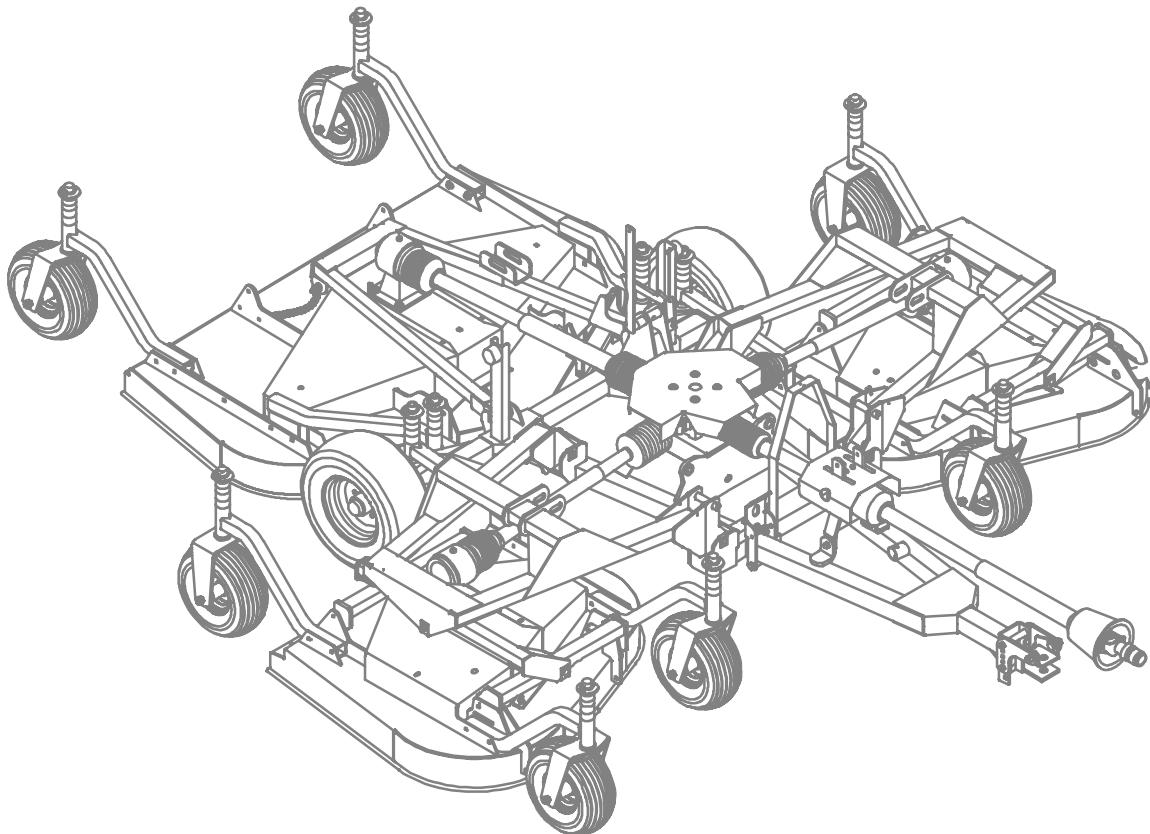

FRONTIER
EQUIPMENT™

TABLE OF CONTENTS

INTRODUCTION	ii
SPECIFICATIONS	1
GENERAL INFORMATION	2
SAFETY RULES	3-6
SAFETY DECALS	7-10
BOLT TORQUE CHART	11
BOLT SIZE CHART	12
OPERATION	13
OWNER SERVICE	18
DEALER SERVICE	23
TROUBLE SHOOTING	30-31
ASSEMBLY INSTRUCTIONS	32
INDEX TO PARTS LISTS	35
INDEX	55
REPLACEMENT PARTS WARRANTY	56
PRODUCT WARRANTY	Inside Back Cover

SPECIFICATIONS

	<u>FM1012R</u>	<u>FM1015R</u>	<u>FM1017R</u>
Cutting Width	12'	15'	17'
Cutting Height Range	1.0" - 5.0"	1.0" - 5.0"	1.0" - 5.0"
Shipping Weight (Approximate)	2,900 lbs.	3,200 lbs.	3,340 lbs.
Blade Speed (Feet per minute - Approximate)	16,950	16,950	16,950
Blades Spindles	7	9	9
Number of Blades	7	9	9
Universal Drive	---(Input: ASAE Cat 4; Wing: ASAE Cat 3)---		
Transport Wheels	20.5 x 8.0-10	20.5 x 8.0-10	20.5 x 8.0-10
Caster Wheels	15 x 6.00-6	15 x 6.00-6	15 x 6.00-6
Tractor PTO Speed RPM	540	540	540
Minimum Tractor Horsepower	30	35	40

Thank you so much for reading.
Please click the “Buy Now!”
button below to download the
complete manual.



After you pay.

You can download the most
perfect and complete manual in
the world immediately.

Our support email:

ebooklibonline@outlook.com