

**OWNER'S / OPERATOR'S MANUAL**

# **3 PT. HITCH BALE UNROLLER**

**BU1060**

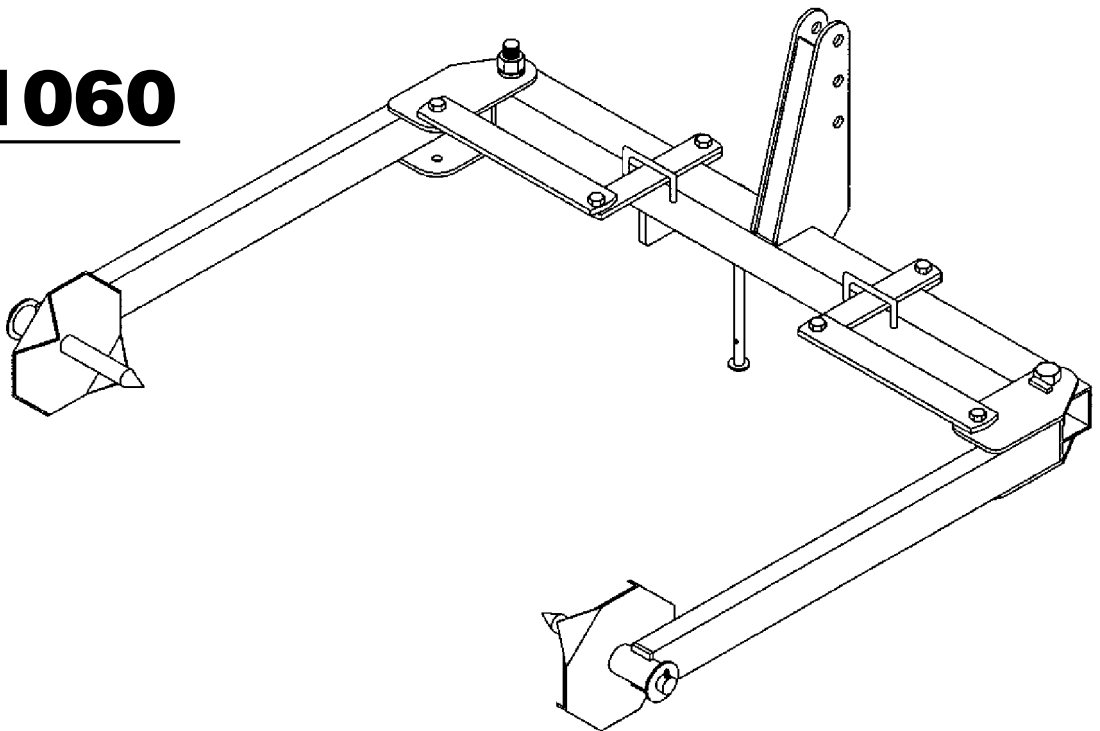

**FRONTIER**  
EQUIPMENT™

# TABLE OF CONTENTS

INTRODUCTION.....	ii - 1
SPECIFICATIONS .....	2
GENERAL INFORMATION .....	2
SAFETY RULES.....	3 - 4
SAFETY DECALS .....	5
DEALER ASSEMBLY.....	6
DEALER CHECK LISTS .....	7
OPERATION.....	8 - 11
OWNER SERVICE.....	12
STORAGE .....	12
TROUBLE-SHOOTING .....	13
PARTS LISTS.....	14 - 15
BOLT TORQUE CHART.....	16
BOLT SIZE CHART & ABBREVIATIONS.....	17
REPLACEMENT PARTS WARRANTY .....	18
PRODUCT WARRANTY.....	19

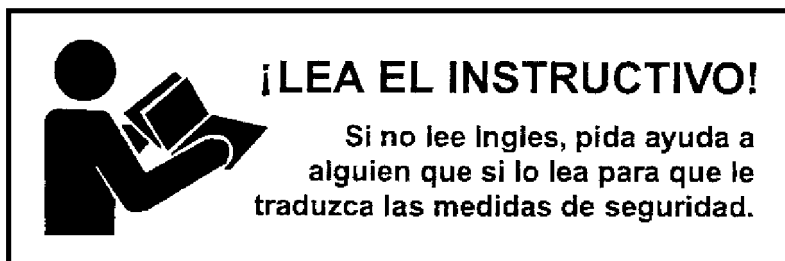

## **1** *Introduction*

Thank you so much for reading.  
Please click the “Buy Now!”  
button below to download the  
complete manual.



After you pay.

You can download the most  
perfect and complete manual in  
the world immediately.

Our support email:

[ebooklibonline@outlook.com](mailto:ebooklibonline@outlook.com)