

**RBX452-462**  
**REPAIR MANUAL**

**6-71260EN**



## SECTION 00 - GENERAL INFORMATION

### Chapter 1 - General Information

#### CONTENTS

<b>Section</b>	<b>Description</b>	<b>Page</b>
00 000	Introduction .....	2
	Precautionary Statements .....	3
	Safety .....	4
	Fluid Safety .....	6
	Safety Decals .....	7
	Information Decals .....	13
	Torques and Adjustments .....	14
	Technical Information .....	15
	Hardware Torque .....	16
	Retaining Compounds and Sealants .....	19
	Standard Torque Data for Hydraulic Tubes and Fittings .....	20
	Lubrication .....	22
	Recommended Lubricants .....	23
	Roller Chains .....	24
	Conversion Charts .....	26
	Ecology and the Environment .....	30
	Baler Components .....	31
	Power Flow – Baler with Stuffer .....	32
	Power Flow – Baler with Rotor .....	33
	Driveline Components Baler with Stuffer and Wide Pickup .....	34
	Driveline Components Baler with Rotor and Wide Pickup .....	35
	Specifications .....	36
	Storage and Seasonal Preparation .....	41

## INTRODUCTION

Appropriate service methods and correct repair procedures are essential for the safe, reliable operation of all equipment, as well as the personal safety of the individual performing the repair.

This Repair Manual provides troubleshooting, overhaul, and technical information needed to properly service the equipment. Following these instructions will ensure the safe, efficient, and timely completion of the service or repair. Use this manual in conjunction with the Operator's Manual for complete operation, adjustment and maintenance information.

There are numerous variations in procedures, techniques, tools, and parts for servicing machines, as well as in the skill of the individual doing the work. This manual cannot possibly anticipate all such variations and provide advice or cautions as to each. Accordingly, anyone who departs from the instructions provided in this manual must first establish that their personal safety, the safety of others, and the integrity of the machine will not be compromised by the choice of methods, tools or parts.

The manual is divided into sections which are subdivided into chapters. Each chapter contains information on general operating principles, detailed inspection, overhaul and, where applicable, specific troubleshooting, special tools, and specifications.

Any reference in this manual to right, left, rear, front, top, or bottom is determined by standing behind the machine and looking in the direction of travel.

All data and illustrations in this manual are subject to variations in build specification. The description and specifications were correct at the time of issue, but company policy is one of continuous improvement. The company reserves the right to change specifications, equipment, or design at any time, without notice.

**NOTE:** *Some photographs in this manual were taken of prototype or previous production models. Current production models may vary in some detail.*

# PRECAUTIONARY STATEMENTS

## PERSONAL SAFETY

Throughout this manual and on machine decals, you will find precautionary statements (“**DANGER**”, “**WARNING**”, and “**CAUTION**”) followed by specific instructions. These precautions are intended for the personal safety of you and those working with you. Please take the time to read them.

---

 **DANGER** 

---

This word “**DANGER**” indicates an immediate hazardous situation that, if not avoided, will result in death or serious injury. The color associated with Danger is **RED**.

---

---

 **WARNING** 

---

This word “**WARNING**” indicates a potentially hazardous situation that, if not avoided, could result in death or serious injury. The color associated with Warning is **ORANGE**.

---

---

 **CAUTION** 

---

This word “**CAUTION**” indicates a potentially hazardous situation that, if not avoided, may result in minor or moderate injury. It may also be used to alert against unsafe practices. The color associated with Caution is **YELLOW**.

---

**FAILURE TO FOLLOW THE “DANGER”, “WARNING”, AND “CAUTION” INSTRUCTIONS MAY RESULT IN SERIOUS BODILY INJURY OR DEATH.**

## MACHINE SAFETY

The precautionary statement (“**IMPORTANT**”) is followed by specific instructions. This statement is intended for machine safety.

**IMPORTANT:** *The word “IMPORTANT” is used to inform the reader of something he needs to know to prevent minor machine damage if a certain procedure is not followed.*

## INFORMATION

**NOTE:** *Instructions used to identify and present supplementary information.*

# SAFETY

## PRECAUTIONARY STATEMENTS

A careful operator is the best operator. Most accidents can be avoided by observing certain precautions. To help prevent accidents, read the following precautions before operating this equipment. Equipment should be operated only by those who are responsible and instructed to do so.

Carefully review the procedures given in this manual with all operators. It is important that all operators be familiar with and follow safety precautions.

### The Round Baler

1. Keep safety decals free of dirt and grime.
2. Replace all damaged, missing or illegible safety decals.
3. Install all shields before operating the round baler.
4. Keep the round baler free of dust, chaff and hay. Always have a fire extinguisher handy.
5. Never operate the round baler without the PTO shield in place. Make sure the PTO shield rotates freely. Make sure the shield chain is attached.

### Towing the Round Baler

1. Do not exceed 32 KPH (20 MPH) when towing the round baler. Do not tow the baler with a bale in the bale chamber.
2. Make sure the SMV, reflective tape and lights are clean and clearly visible.
3. Refer to local, state or provincial laws and regulations for restrictions on public roads.
4. Make sure the taillights are operating properly.
5. Raise and secure the pickup in its highest position.
6. On balers with a 2.1 meter wide pickup, move the gauge wheels to the transport position.

### Operating the Round Baler

1. Read the Operator's Manual before operating the round baler.
2. Only allow properly trained persons to operate the round baler.
3. Allow only one operator on the tractor.

4. Do not permit anyone to ride on the round baler.
5. Do not engage the PTO before you are sure everyone is clear of the round baler.
6. Do not work around the round baler in loose clothing that might catch in moving parts.
7. Do not attempt to pull crop from the round baler without turning off the PTO.
8. Keep hands away from the twine knife. Be sure all persons are clear of the baler before operating the twine tubes.
9. If the twine does not start, stop the round baler before correcting the problem.
10. Keep hands away from the net knife.
11. Do not operate above the rated PTO speed.
12. Do not back over windrows, the hay may wedge between the floor roll and pickup.
13. Do not make overweight bales. The round baler may be damaged.
14. Do not exceed the full bale size. An oversize bale will put excessive stress on the round baler components.
15. Be sure all persons are clear of the round baler before starting the round baler, activating the wrapper or opening the tailgate.
16. Do not adjust the pickup lower than necessary.
17. When operating on slopes, the bale must be ejected on the side of the slope to prevent the bale from rolling into the baler or down the hill.
18. Avoid contact with electric power lines. Be especially careful when opening the tailgate.

### **Servicing the Round Baler**

1. Do not service the round baler with the tailgate in the raised position unless the valve safety lock is in the locked position.
2. Make sure the PTO drive is disengaged, the tractor engine is shut off and the electric power supply to the baler is disconnected before doing any lubrication, maintenance, or service work on the baler.
3. Park on level ground and block the wheels to prevent the round baler from rolling.
4. Do not adjust the belts with the round baler running.
5. Do not oil the chains with the baler running.
6. Do not modify or allow anyone else to modify the round baler without consulting the dealer.
7. Escaping hydraulic fluid under pressure can penetrate the skin causing serious injury.
  - Do not use your hand to check for leaks. Use a piece of cardboard or paper.
- Stop the engine and relieve the pressure before connecting or disconnecting hydraulic lines.
- Tighten all connections before starting the engine or pressurizing the hydraulic lines.
- If hydraulic fluid penetrates the skin, obtain medical attention immediately.
- Continuous long term contact with hydraulic fluid may cause skin cancer. Avoid long term contact and wash the skin promptly with soap and water.
8. To protect the alternator and battery of the tractor, always detach the tractor from the baler before welding or working on the baler electrical components.
9. Always chock the wheels before working on the baler.
10. Hydraulic flexible hose assemblies must be inspected periodically for signs of abrasive rubbing of the cover, leakage, or impending failure and appropriate corrective action taken to help prevent unexpected assembly failures.

## FLUID SAFETY

### HANDLE FLUIDS SAFELY

When you work around fuel or other flammable material, do not smoke, work near heaters or other fire hazards.

Do not store flammable material in open containers.

Store flammable fluids away from fire hazards.

Do not incinerate or puncture pressurized containers.

Make sure machine is clean of trash, grease, oil, and debris.

Do not store oily rags; they can ignite and burn spontaneously.

Keep a first aid kit and fire extinguisher handy.

Keep emergency numbers for doctors, ambulance service, hospital, and fire department near your telephone.

### AVOID HEATING NEAR PRESSURIZED FLUID LINES

Flammable spray can be generated by heating near pressurized fluid lines, resulting in severe burns to yourself and bystanders.

Do not heat by welding, soldering, or using a torch near pressurized fluid lines.

Pressurized lines can be accidentally cut or damaged when heat goes beyond the immediate flame area.

### USE CARE AROUND HIGH-PRESSURE FLUID LINES

Escaping fluid under pressure can penetrate the skin causing serious injury.

Avoid the hazard by relieving pressure before disconnecting hydraulic or other lines.

Tighten all line connections before applying pressure.

Check for leaks with a piece of cardboard.

Protect hands and body from high pressure fluids.

If an accident occurs, see a doctor immediately. Any fluid injected into the skin must be surgically removed within a few hours or gangrene may result. Doctors unfamiliar with this type of injury should reference a knowledgeable medical source.

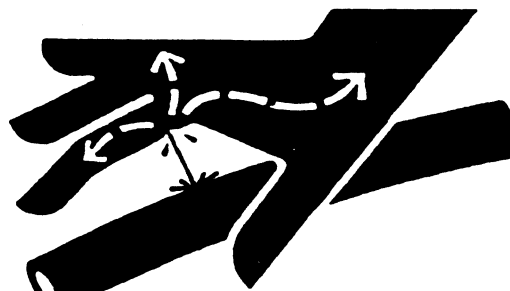

### SAFE SERVICE PROCEDURES

Wear protective clothing.

Do not wear loose clothing.

Wear close fitting clothing.

Wear safety glasses or face shield as required.

Wear other safety equipment appropriate to the job.

Wear earplugs or earmuffs as required.

Use caution when working around moving parts.

Use tools appropriate for the job.

Replace missing or damaged safety decals.

Reinstall all shielding removed for servicing.

Replace any damaged or missing shielding.

## SAFETY DECALS

The following safety decals have been placed on your machine in the areas indicated. They are intended for your personal safety and for those working with you. Please take this manual and walk around your machine to note the content and location of these warning signs. Review these warning signs

and the operating instructions detailed in this manual with your machine operators.

Keep the decals legible. If they are not, obtain replacements from your authorized dealer. The decal replacement part numbers are listed with each decal.

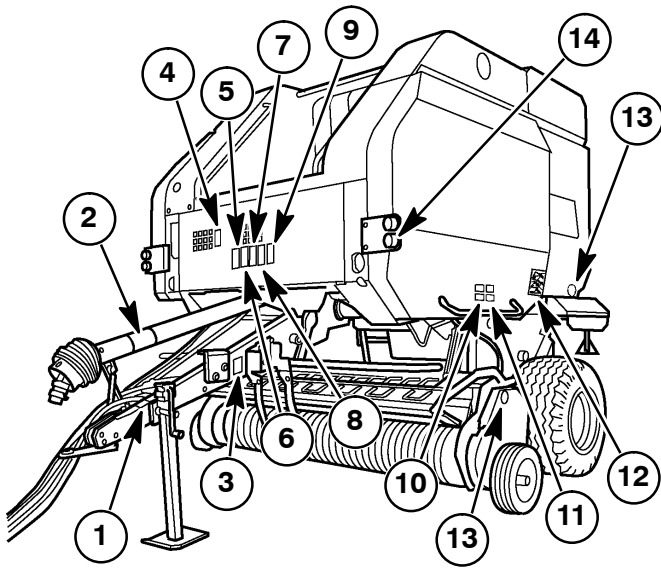

10022329

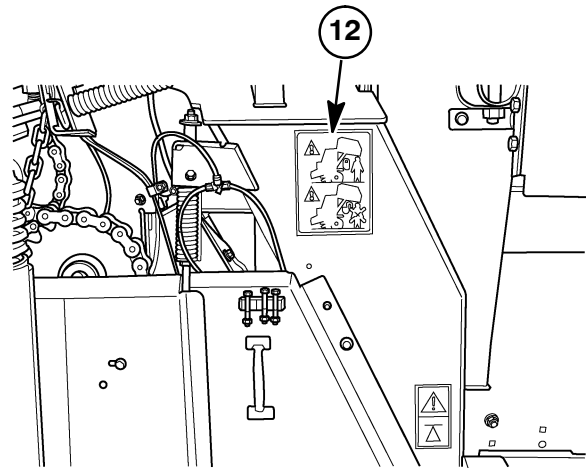

10022313

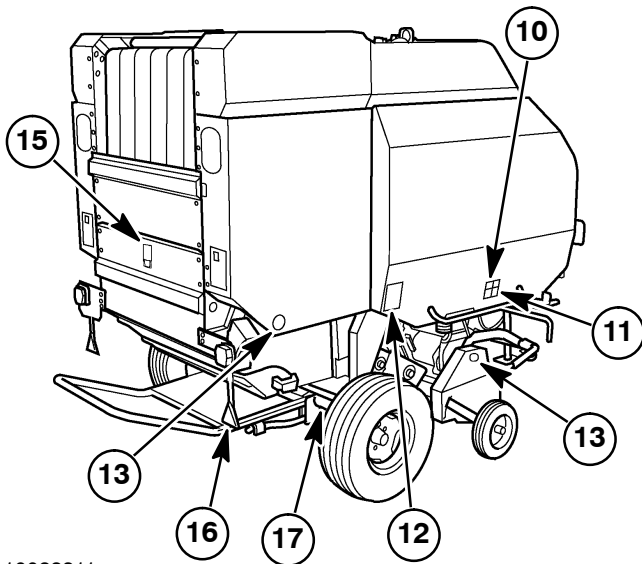

10022311

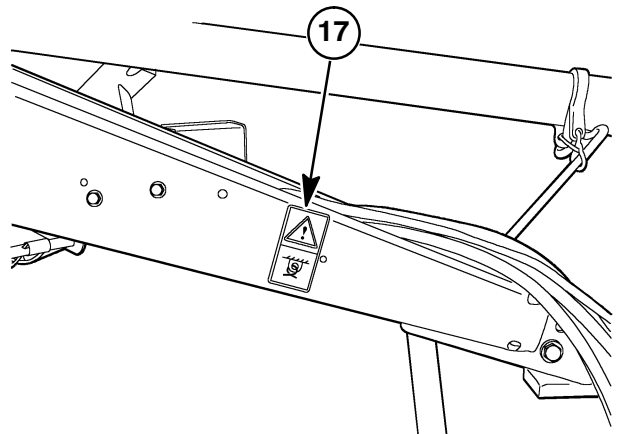

50022358



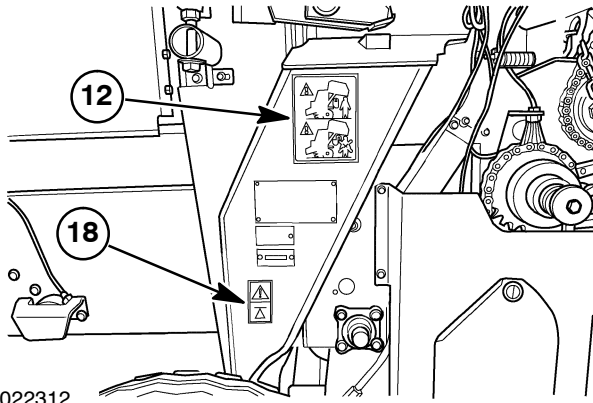

10022312

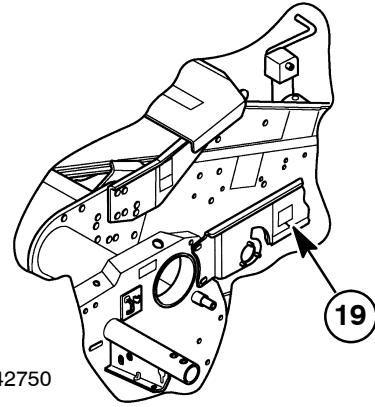

10042750

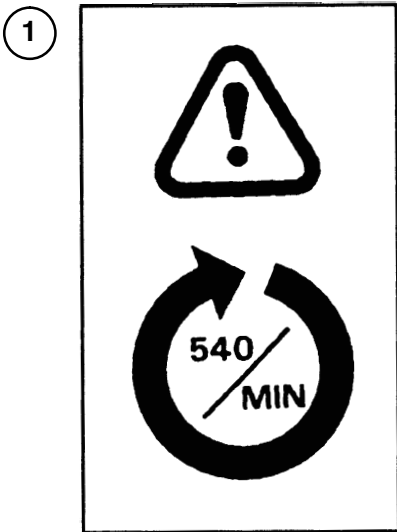

DANGER: Rotating driveline 540 RPM. Keep all PTO guards serviced and in place. Injury or death can result from wrapping or entanglement.

Part #730650

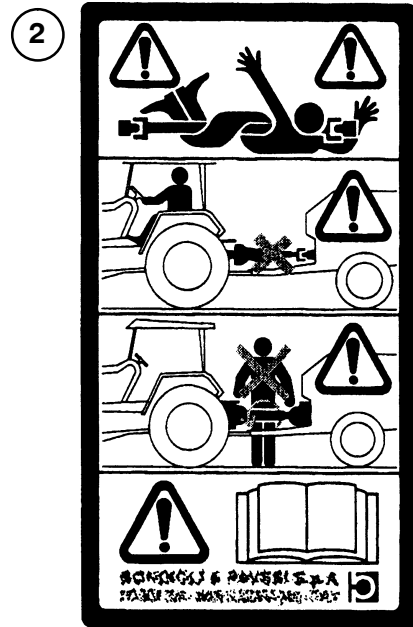

DANGER: This decal is located on the PTO telescoping shafts, outside and inside the PTO guards. The inside decal is exposed when the guard is missing.

It warns the operator not to operate the baler with the PTO shaft guard missing.

Part #86520950



ITALY ONLY

Do not park on public roads.

Part #87017104

4

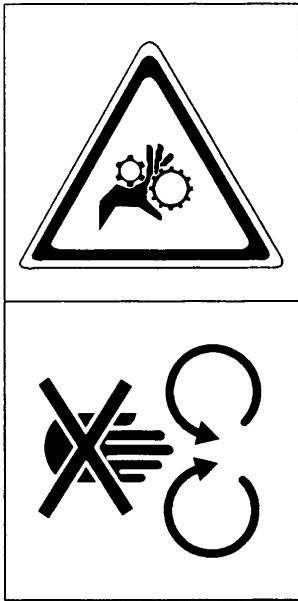

- Do not open or remove safety guards while the tractor is running.
- Do not reach through the inspection doors while the tractor is running.

Part #84014114

5

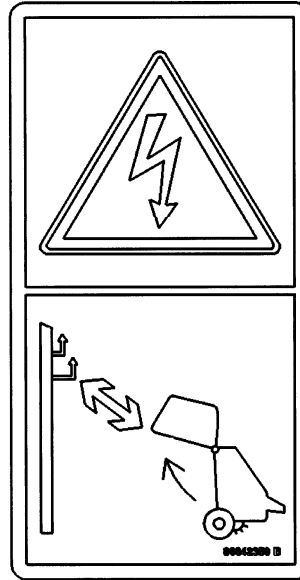

DANGER: Avoid contact with power lines.

Part #86642359

6

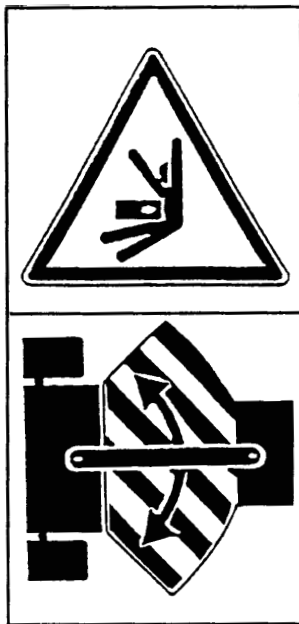

Stay clear of the baler hitch articulation area when engine is running.

Part #84014115

7



Do not ride on the PTO platform, steps or guards.

Part #84004732

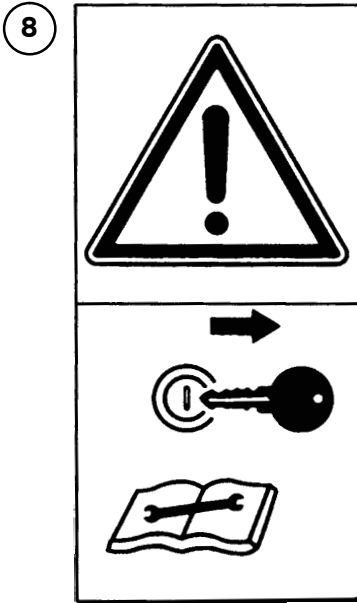

Disengage the tractor PTO, shut off the engine and remove the ignition key, apply the handbrake before performing maintenance or repair work.

Part #84004744

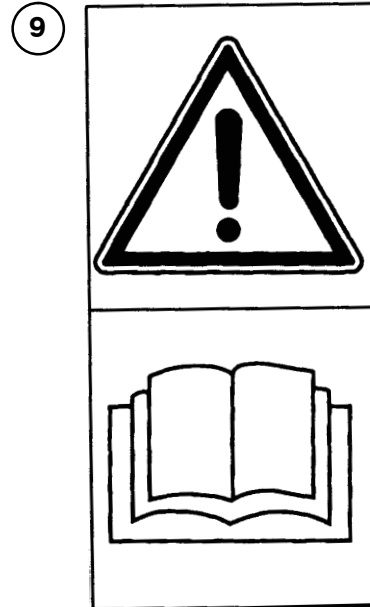

Carefully read the Operator's Manual before operating the machine. Observe instructions and safety rules when operating.

Part #84004731



- Keep all safety guards in place.
- Do not open or remove safety shield while the tractor engine is running.
- Wait until all parts have stopped before carrying out any maintenance work on the baler.
- Stand clear from all moving parts.

Part #84004734



- Never reach into the rotating auger.
- Never attempt to unplug the pick-up while the tractor engine is running. Injury or death can result from catching or entanglement.

Part #84004736

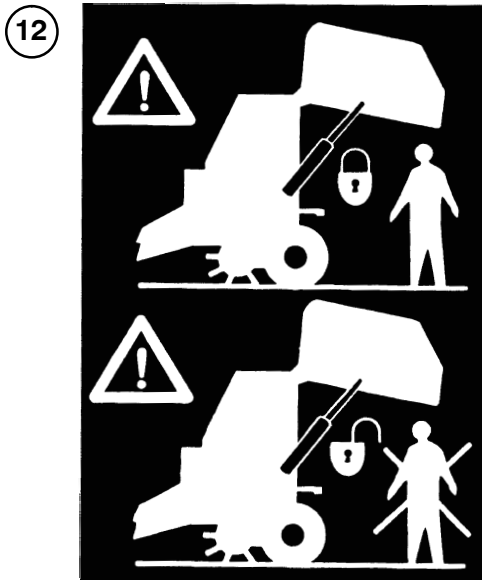

**DANGER:** Engage the tailgate lock before working under or around the tailgate in the raised position.

Stand clear before unlocking the tailgate lock.

Failure to do so may allow the tailgate to close faster than you can move away and may result in death or serious injury.

Part #9846526

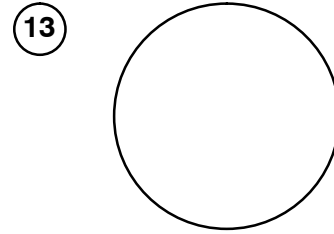

ORANGE REFLECTOR

Part #435895

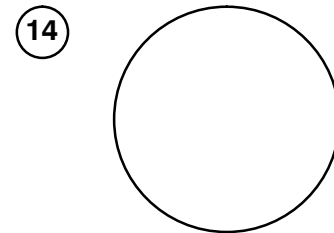

WHITE REFLECTOR

Part #336483



**DANGER:** Stand clear of sides and rear of this machine.

The tailgate opens faster than you can move away.

Failure to do so may result in death or serious injury.

Part #86516139

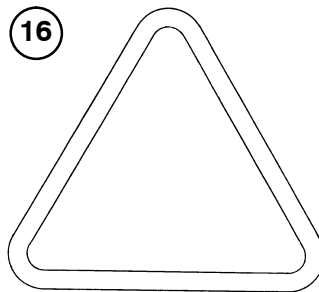

SMV RED REFLECTOR

Part #746294



Use this area to tie down the unit.

Part #84100296

18

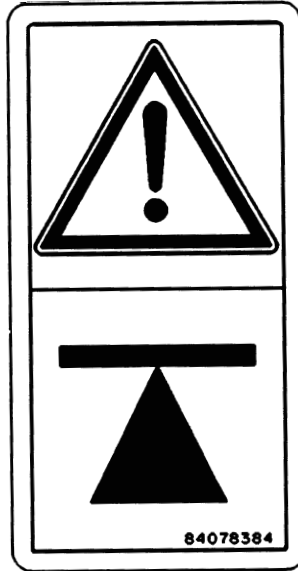

Jack the unit up in this area.  
Part #84078384

19

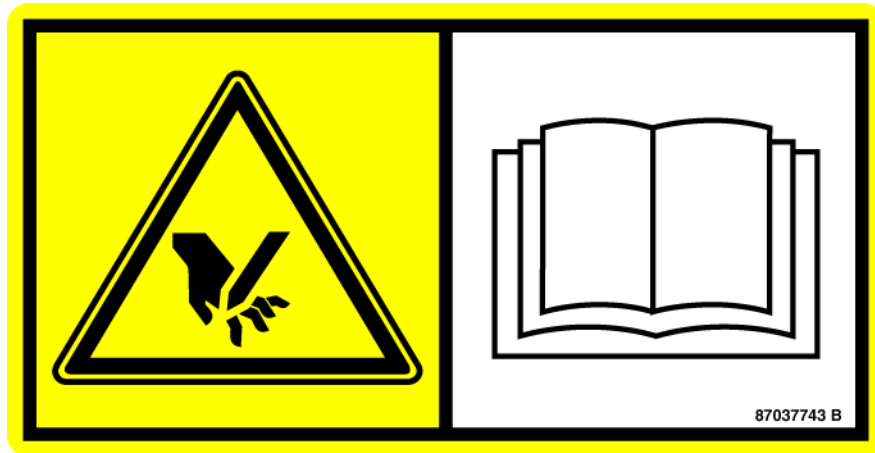

**WARNING:** Retract knife to home position  
before threading net or servicing machine.  
Part #87037743

### INFORMATION DECALS

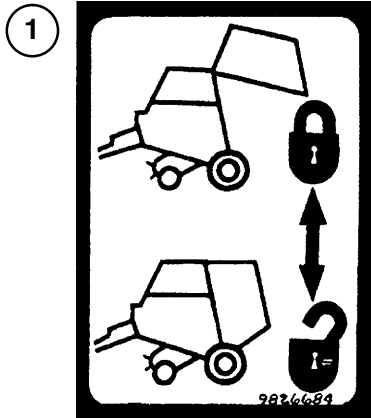

TAILGATE LOCK  
Part #9826684

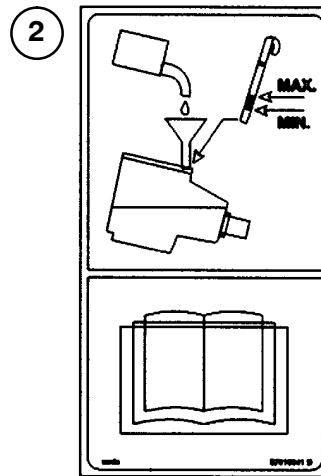

GEARBOX OIL LEVEL  
Part #87018641

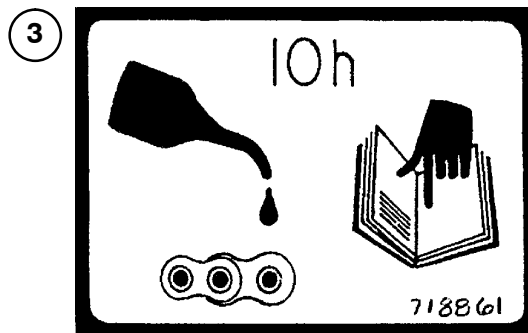

OIL CHAINS  
(Refer to Operators Manual)  
Part #718861

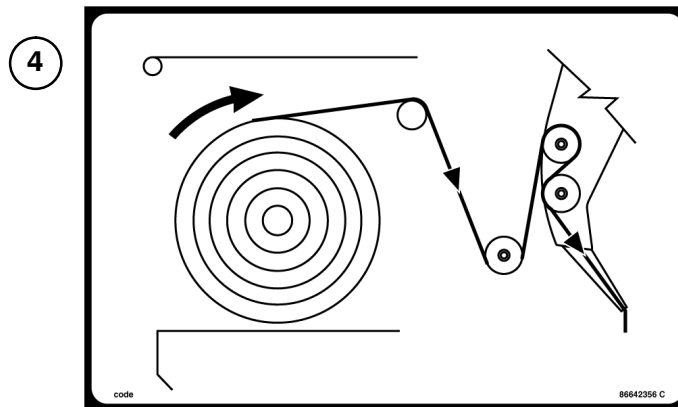

NET ROUTING  
Part #86642356

## TORQUES AND ADJUSTMENTS

### TORQUES

Wheel bolts	156 N·m (115 ft.-lbs.)
19/45-17	380 N·m (289 ft.-lbs.)
Cam follower bearing	61 N·m (45 ft.-lbs.)
Pickup finger	15 N·m (133 in.-lbs.)
PTO on gearbox	142 N·m (105 ft.-lbs.)

### ADJUSTMENTS

Tire pressure	
31-13.5x15, 8 ply	234 kPa (34 psi)
19/45-17, 10 ply	193 kPa to 220 kPa (28 psi to 32 psi)
4.8x4-8, 4 ply	104 kPa (15 psi)
16.5x6.5-8, 4 ply	204 kPa to 275 kPa (35 psi to 40 psi)
Net wrapper brake pad	2 to 4 mm (3/32 to 5/32")
Brake spring	machines built on or before 09/03: 180 to 186 mm (7-1/8 to 7-5/16") machines built after 09/03: 119 to 123 mm (4-11/16 to 4-27/32")
Duckbill spring	384 to 390 mm (15-1/8 to 15-3/8")
Knife spring	289 to 295 mm (11-3/8 to 11-5/8")
Twine wrapper	
Knife tension springs	64 mm (2-1/2")
Wide PU drive chain idler spring	130 mm (5-1/8")
Sledge slip clutch	677 to 767 N·m (500 to 567 ft.-lbs.)

## TECHNICAL INFORMATION

### HARDWARE

#### General

The round balers have been built using mostly metric hardware. However, there are some places where inch hardware is required.

**NOTE:** *Be sure to use the hardware specified when using tapped holes, as trying to install a metric bolt in an inch thread, or an inch bolt in a metric thread, will damage the thread.*

The standard metric hardware callouts are for example M8 x 16. The M indicates metric. The first number (8) is the diameter in millimeters. The second number (16) is the length in millimeters. Following the numbers there may be a letter designation such as CS (cap screw) or CB (carriage bolt).

Certain hardware must be tightened to specific torque specifications. If specific torque specifications are not noted, tighten the hardware to the standard torque chart specification listed in this manual.

#### Plating

Hardware used is plated with zinc chromate (gold color). Gold colored hardware has different torquing requirements from unplated or zinc plated (silver color) hardware because of the difference in the coefficient of friction of the plating material. The torque charts in this manual list the correct specifications for gold, silver, and unplated bolts.

#### Nut Tightening

Whenever possible, the nut should be tightened, not the head of the bolt. When tightening using the bolt head, the clamp load can be lost because some of the torque applied twists the bolt instead of tensioning (stretching) it. The tension on the bolt is what holds the joint together.

Approximately 90% of the torque applied during assembly goes to overcoming friction between the parts. The other 10% is used to tension (stretch) the bolt. After assembly, the frictional forces disappear, which is the basis for the saying “If it does not fail during assembly, it will not fail in service.” The bolt may later fail due to other factors, but not from being over tightened.

#### Locknuts

Most locknuts are coated with a special lubricant that is dry to the touch. Anytime a locknut is used, a lower than normal torque is required. Refer to the torque charts in this manual for specific values.

#### Jam Nuts

When using a jam nut to lock a regular nut, the jam nut should be installed first and tightened to one half the recommended torque, then held in place while installing a regular nut to the recommended torque.

#### Thread Lubrication

The addition of antiseize compound, Molykote, oil, graphite, or any other lubricant to a bolt decreases the friction between it and a nut. This makes it necessary to reduce the recommended torque to prevent over tensioning of the bolt. When using the torque charts in this manual, decrease the value by 20% whenever a lubricant is used.

#### Tapered Splines

In an installation where a component such as a fly-wheel, shaft, gear, etc. is attached to a shaft with tapered splines and held in place with a washer and cap screw, it must be hammer seated.

Be sure the splines in both components are clean. Install the component. Be sure the shaft does not protrude through the component; if it does, check for excessive wear in either component. Install the washer and cap screw. Tighten the cap screw to the corresponding torque for that bolt size or to the specified torque for that component.

Strike the hub of the component with a hammer or use a punch and hammer if necessary. Recheck the torque. Repeat the process until the torque of the bolt holds.

**NOTE:** *The washer must not bottom out on the shaft before the component is tight.*



# MINIMUM HARDWARE TIGHTENING TORQUES

IN NEWTON-METERS (FOOT POUNDS) FOR NORMAL ASSEMBLY APPLICATIONS

## METRIC NON-FLANGED HARDWARE AND LOCKNUTS

NOMINAL SIZE	CLASS 5.8		CLASS 8.8		CLASS 10.9		LOCKNUT CL.8 W/CL.8.8 BOLT
	UNPLATED	PLATED W/ZnCr	UNPLATED	PLATED W/ZnCr	UNPLATED	PLATED W/ZnCr	
M4	1.7 (15)*	2.2 (19)*	2.6 (23)*	3.4 (30)*	3.7 (33)*	4.8 (42)*	2.3 (20)*
M6	5.8 (51)*	7.6 (67)*	8.9 (79)*	12 (102)*	13 (115)*	17 (150)*	7.8 (69)*
M8	14 (124)*	18 (159)*	22 (195)*	28 (248)*	31 (274)*	40 (354)*	19 (169)*
M10	28 (21)	36 (27)	43 (32)	56 (41)	61 (45)	79 (58)	38 (28)
M12	49 (36)	63 (46)	75 (55)	97 (72)	107 (79)	138 (102)	66 (49)
M16	121 (89)	158 (117)	186 (137)	240 (177)	266 (196)	344 (254)	164 (121)
M20	237 (175)	307 (226)	375 (277)	485 (358)	519 (383)	671 (495)	330 (243)
M24	411 (303)	531 (392)	648 (478)	839 (619)	897 (662)	1160 (855)	572 (422)

NOTE: Torque values shown with \* are inch pounds.

### IDENTIFICATION HEX CAP SCREW AND CARRIAGE BOLTS CLASSES 5.6 AND UP

#### MANUFACTURER'S IDENTIFICATION

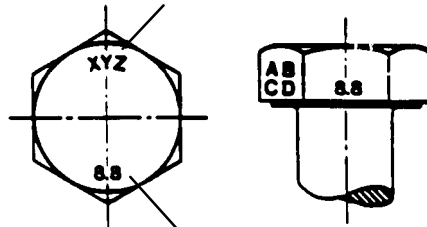

#### PROPERTY CLASS

### HEX NUTS AND LOCKNUTS CLASSES 05 AND UP

#### MANUFACTURER'S IDENTIFICATION

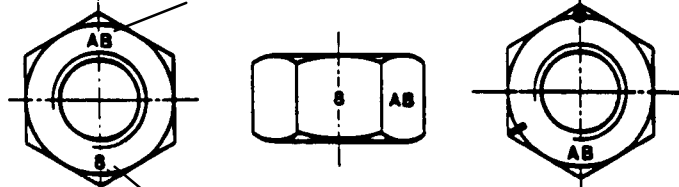

#### PROPERTY CLASS

#### CLOCK MARKING

# MINIMUM HARDWARE TIGHTENING TORQUES

IN NEWTON-METERS (FOOT POUNDS) FOR NORMAL ASSEMBLY APPLICATIONS

## INCH NON-FLANGED HARDWARE AND LOCKNUTS

NOMINAL SIZE	SAE GRADE 2		SAE GRADE 5		SAE GRADE 8		LOCKNUTS		NOMINAL SIZE
	UNPLATED or PLATED SILVER	PLATED W/ZnCr GOLD	UNPLATED or PLATED SILVER	PLATED W/ZnCr GOLD	UNPLATED or PLATED SILVER	PLATED W/ZnCr GOLD	GR.B w/GR5 BOLT	GR.C w/GR8 BOLT	
1/4	6.2 (55)*	8.1 (72)*	9.7 (86)*	13 (112)*	14 (121)*	18 (157)*	8.5 (75)*	12.2 (109)*	1/4
5/16	13 (115)*	17 (149)*	20 (178)*	26 (229)*	28 (250)*	37 (324)*	17.5 (155)*	25 (220)*	5/16
3/8	23 (17)	30 (22)	35 (26)	46 (34)	50 (37)	65 (48)	31 (23)	44 (33)	3/8
7/16	37 (27)	47 (35)	57 (42)	73 (54)	80 (59)	104 (77)	50 (37)	71 (53)	7/16
1/2	57 (42)	73 (54)	87 (64)	113 (83)	123 (91)	159 (117)	76 (56)	108 (80)	1/2
9/16	81 (60)	104 (77)	125 (92)	163 (120)	176 (130)	229 (169)	111 (82)	156 (115)	9/16
5/8	112 (83)	145 (107)	174 (128)	224 (165)	244 (180)	316 (233)	153 (113)	215 (159)	5/8
3/4	198 (146)	256 (189)	306 (226)	397 (293)	432 (319)	560 (413)	271 (200)	383 (282)	3/4
7/8	193 (142)	248 (183)	495 (365)	641 (473)	698 (515)	904 (667)	437 (323)	617 (455)	7/8
1	289 (213)	373 (275)	742 (547)	960 (708)	1048 (773)	1356 (1000)	654 (483)	924 (681)	1

NOTE: Torque values shown with \* are inch pounds.

### IDENTIFICATION CAP SCREWS AND CARRIAGE BOLTS



### LOCKNUTS

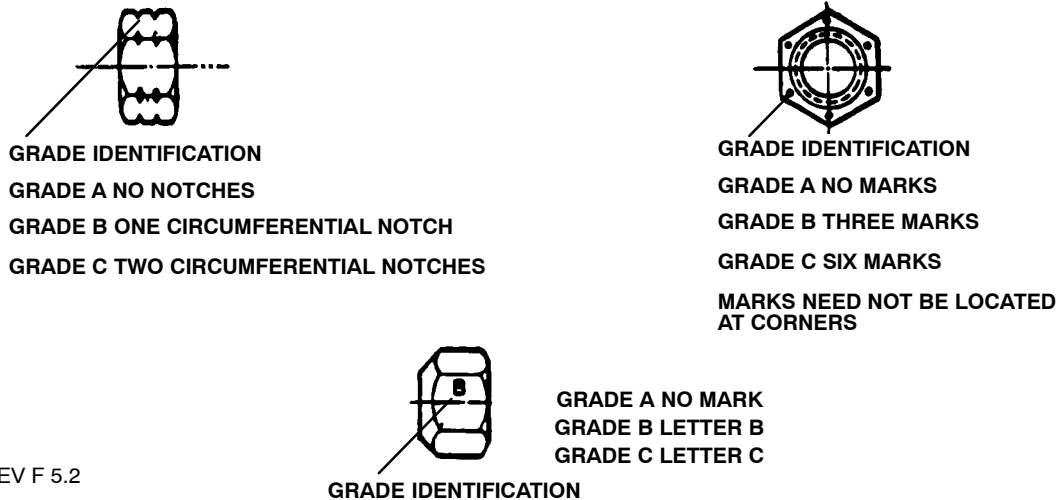

*SECTION 00 – GENERAL INFORMATION – CHAPTER 1*

<b>Socket or Wrench Size</b>	
<b>U.S. Standard (Inch)</b>	
<b>Bolt Diameter</b>	<b>Bolt Head</b>
1/4	3/8
5/16	1/2
3/8	9/16
7/16	5/8
1/2	3/4
9/16	7/8
5/8	15/16
3/4	1 1/8
7/8	1 5/16
1	1 1/2

<b>Socket or Wrench Size</b>	
<b>Metric</b>	
<b>Bolt Diameter</b>	<b>Bolt Head</b>
6 mm	10 mm
8 mm	13 mm
10 mm	17 mm
12 mm	19 mm
14 mm	22 mm
16 mm	24 mm
18 mm	27 mm
22 mm	32 mm
24 mm	36 mm

## RETAINING COMPOUNDS AND SEALANTS

### THREAD LOCKING COMPOUNDS

Grade	Color	Loctite#	Permabond#	Hernon#
Nut	blue	242	MM-115	423
Stud	red	271		
Stud	red	277		429
Wicking	green	290		

### RETAINING COMPOUNDS

Fit	Color	Loctite#
Press	green	609
Slip	green	680
Loose	green	638

### SEALANTS

Application	Color	Vendor#
Gasket eliminator	purple	Loctite #515
Gasketing		Hernon #910
Hydraulic sealer	brown	Loctite #569

## STANDARD TORQUE DATA FOR HYDRAULIC TUBES AND FITTINGS

SIZE	TUBE NUTS FOR 37 FLARED FITTINGS						O RING BOSS PLUGS ADJUSTABLE FITTING LOCKNUTS, SWIVEL JIC-37 SEATS				
	TUBING OD		THREAD SIZE	TORQUE				TORQUE			
	mm	in.		NEWTON METERS		FOOT POUNDS		NEWTON METERS		FOOT POUNDS	
			Min.	Max.	Min.	Max.	Min.	Max.	Min.	Max.	
4	6.4	1/4	7/16-20	12	16	9	12	8	14	6	10
5	7.9	5/16	1/2-20	16	20	12	15	14	20	10	15
6	9.5	3/8	9/16-18	29	33	21	24	20	27	15	20
8	12.7	1/2	3/4-18	47	54	35	40	34	41	25	30
10	15.9	5/8	7/8-14	72	79	53	53	47	54	35	40
12	19.1	3/4	1 1/8-12	104	111	77	82	81	95	60	70
14	22.2	7/8	1 3/16-12	122	136	90	100	95	109	70	80
16	25.4	1	1 5/16-12	149	163	110	120	108	122	80	90
20	31.8	1 1/4	1 5/8-12	190	204	140	150	129	158	95	115
24	38.1	1 1/2	1 7/8-12	217	237	160	175	163	190	120	140
32	50.8	2	2 1/2-12	305	325	225	240	339	407	250	300

These torques are not recommended for tubes of 12.7 mm (1/2") OD and larger with wall thickness of 0.889 mm (0.035") or less. The torque is specified for 0.889 mm (0.035") wall tubes on each application individually.

Before installing and torquing 37° flared fittings, clean the face of the flare and threads with a clean solvent or Loctite cleaner and apply hydraulic sealant Loctite #569 to the 37° flare and the threads.

Install fitting and torque to specified torque, loosen fitting and retorque to specifications.

**INSTALLATION OF ADJUSTABLE FITTINGS IN STRAIGHT THREAD O RING BOSSES**

1. Lubricate the O ring by coating it with a light oil or petroleum. Install the O ring in the groove adjacent to the metal backup washer which is assembled at the extreme end of the groove, 4.
2. Install the fitting into the SAE straight thread boss until the metal backup washer contacts the face of the boss, 5.

**NOTE:** Do not over tighten and distort the metal backup washer.

3. Position the fitting by turning out (counterclockwise) up to a maximum of one turn. Holding the pad of the fitting with a wrench, tighten the locknut and washer against the face of the boss, 6.

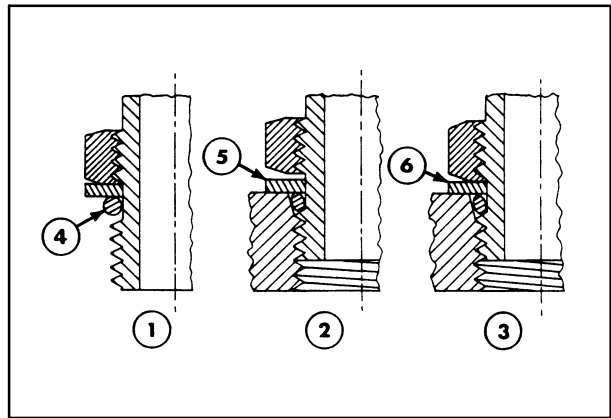

1

**PIPE THREAD FITTING TORQUE**

Before installing and tightening pipe fittings, clean the threads with a clean solvent or Loctite cleaner and apply sealant Loctite no. 567 for all fittings including stainless steel or no. 565 for most metal fittings. For high filtration/zero contamination systems use no. 545.

THREAD SIZE	TORQUE (MAXIMUM)
1/8" - 27	13 N·m (10 ft lbs)
1/4" - 18	16 N·m (12 ft lbs)
3/8" - 14	22 N·m (16 ft lbs)
1/2" - 14	41 N·m (30 ft lbs)
3/4" □ 14	54 N·m (40 ft lbs)

**INSTALLATION OF ORFS (O RING FLAT FACED) FITTINGS**

When installing ORFS fittings thoroughly clean both flat surfaces of the fitting, 1, and lubricate the O ring, 2, with light oil. Make sure both surfaces are aligned properly. Torque the fitting to specified torque listed throughout the repair manual.

**IMPORTANT:** If the fitting surfaces are not properly cleaned, the O ring will not seal properly. If the fitting surfaces are not properly aligned, the fittings may be damaged and will not seal properly.

**IMPORTANT:** Always use genuine replacement oils and filters to ensure proper lubrication and filtration of engine and hydraulic system oils.

The use of proper oils, grease, and keeping the hydraulic system clean will extend machine and component life.

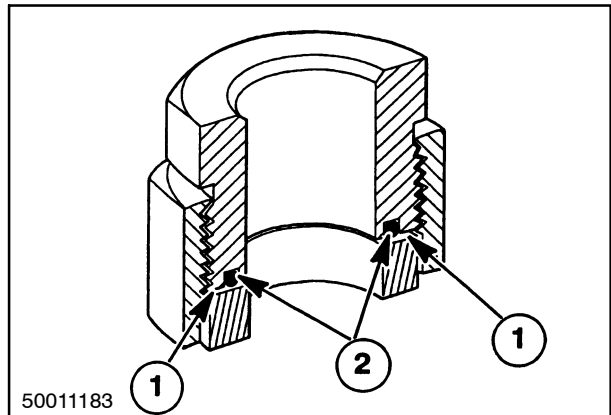

50011183

2

# LUBRICATION

Adequate lubrication and maintenance on a regular schedule is vital to maintaining your equipment. To ensure long service and efficient operation, follow the lubrication and maintenance schedules outlined in this manual. The use of proper fuels, oils, grease and filters, as well as keeping the systems clean, will also extend machine and component life.

**IMPORTANT:** Always use genuine **Case IH** replacement parts, oils and filters to ensure proper operation, filtration of engine and hydraulic systems. See your **Case IH** dealer for additional oil quantities.

## GENERAL INFORMATION

Regular lubrication is the best insurance against delays and repairs. Proper lubrication will extend machine life. Refer to the following charts for lubricants and service intervals.

**IMPORTANT:** Failure to complete the required maintenance at the recommended intervals can cause unnecessary downtime.

The intervals listed in the Lubrication Chart are guidelines to be used when operating in normal conditions. Adjust the intervals for operating in adverse environmental and working conditions. The intervals should be shortened for sandy, dusty and extremely hot operating conditions.

---

## CAUTION

---

Observe these safety precautions before performing lubrication and maintenance.

1. Shut off engine.
  2. Disengage all drives.
  3. Lower all attachments to the ground or raise and engage all locks
  4. Close all shields opened and reinstall any shields removed for lubrication and maintenance purposes.
- 

---

## CAUTION

---

Some illustrations in this manual show shields opened or removed to show areas being serviced. Replace all shields before operating this machine.

---

Always clean the area around dipsticks, fill caps, and check plugs when checking fluid levels. Failure to clean these areas may allow contamination to enter the system. Drain, flush and refill the system anytime you suspect it is contaminated.

### Grease Fittings

Wipe dirt from fittings before greasing.

Pump fresh grease into fitting to adequately lubricate the component and force out any contamination from the grease passage.

Wipe off excess grease.

Use a grease gun containing clean high grade of multipurpose grease.

### Chains

Stop all drives before lubricating chains.

**RECOMMENDED LUBRICANTS**

<b>Lubricant</b>	<b>Type and Description</b>
<b>Engine Oil</b>	AKCELA NO. 1 SSL OIL SAE 0W-40
	AKCELA NO. 1 OIL SAE 10W
	AKCELA NO. 1 OIL SAE 10W-30
	AKCELA NO. 1 OIL SAE 30
	AKCELA NO. 1 OIL SAE 15W-40
	AKCELA NO. 1 OIL SAE 20W-50
	AKCELA AUTO SUPREME SAE 5W-30
	AKCELA AUTO SUPREME SAE 10W-30
	AKCELA LOW ASH OIL SAE 10W
AKCELA LOW ASH OIL SAE 30	
<b>Transmission Oil</b>	AKCELA HY-TRAN ULTRA
	AKCELA HY-TRAN ULTRA SSL
	AKCELA TSM BIO
<b>Hydraulic Oil</b>	AKCELA AW46 HYD FLUID
	AKCELA AW68 HYD FLUID
	AKCELA AW100 HYD FLUID
	AKCELA HYDRAULIC EXCAVATOR FLUID
	AKCELA TCH FLUID
<b>ATF Oil</b>	TRANS. XHD
<b>Gear Oil</b>	AKCELA 135H EP GEAR LUBE SAE 80W-90
	AKCELA 135H EP GEAR LUBE SAE 85W-140
	AKCELA TRANSAXLE FLUID
	AKCELA GEAR LUBE SSL
<b>Grease</b>	AKCELA 251H EP MULTI-PURPOSE GREASE
	AKCELA PREMIUM GREASE EP-2
	AKCELA EP-0 GREASE
	AKCELA CORN HEAD GREASE
	AKCELA MOLY GREASE
	AKCELA SSL SYNTHETIC GREASE
	AKCELA HTO ADDITIVE
	AKCELA HTO PREMIX
	AKCELA LIMITED SLIP ADDITIVE
AKCELA AXLE OIL ADDITIVE	
<b>Brake Oil</b>	AKCELA CRAWLER BRAKE OIL
<b>Special Lubricants</b>	AKCELA AG LUBRICANT
	AKCELA DURAFIT SPINDLE GREASE
	AKCELA COTTON PICKER BAR LUBE
	AKCELA HI-SPEED SPINDLE CLEANER



## ROLLER CHAINS

### Chain Wear

The individual joints in a roller chain articulate as they enter and leave the sprockets. This articulation results in wear on the pins and bushings. As material is worn away from these surfaces the chain will gradually elongate.

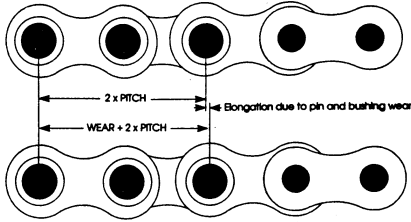

CHAIN DOES NOT "STRETCH" – MATERIAL IS REMOVED FROM PIN AND BUSHING

Elongation is normal and may be minimized by proper lubrication and drive maintenance. The rate of wear is dependent upon: the relationship between the load and the amount of bearing area between pin and bushing, the material and surface condition of the bearing surfaces, the adequacy of lubrication, and the frequency and degree of articulation between pins and bushings. The latter is determined by the quantity of sprockets in the drive, their speeds, the number of teeth and the length of the chain in pitches.

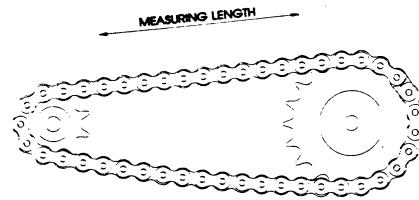

MEASUREMENT OF CHAIN FOR WEAR ELONGATION

Relatively accurate wear measurements can be made by using the above illustration. Measure as closely as possible from the center of one pin to the center of another. The more pitches (pins) contained within the measurement increase the accuracy. If the measured value exceeds the nominal by more than the allowable percentage the chain should be replaced. The maximum allowable wear elongation is approximately 3% for most industrial applications, based upon sprocket design. The allowable chain wear in percent can be calculated using the relationship:  $200/N$ , where  $N$  is the number of teeth in the large sprocket. This relationship is often useful since the normal maximum allowable chain wear elongation of 3% is valid only up to 67 teeth in the large sprocket. In drives having fixed center distances, chains running in parallel or where smoother operation is required, wear should be limited to approximately 1.5%.

For example, if 12 pitches (12 pins) of a #80 chain were measured and the result was 12.360 or greater (using 3% as the maximum allowable wear), the chain should be replaced. Anything less than 12.360 would still be acceptable by most industrial standards.

**SECTION 00 – GENERAL INFORMATION – CHAPTER 1**

<b>WEAR LIMITS ON ROLLER CHAINS</b>								
<b>Strand Length In Pitches</b>	<b>Chain Length in Millimeters (Inches)</b>							
	<b>No. 40 Chain (08A)</b>		<b>No. 50 Chain (10A)</b>		<b>No. 60 Chain (12A)</b>		<b>No. 80 Chain (16A)</b>	
	<b>New</b>	<b>Old (Replace)</b>	<b>New</b>	<b>Old (Replace)</b>	<b>New</b>	<b>Old (Replace)</b>	<b>New</b>	<b>Old (Replace)</b>
40P	508 (20)	523 (20 5/8)	635 (25)	654 (25 3/4)	762 (30)	787 (31)	1016 (40)	1047 (41 1/4)
50P	635 (25)	654 (25 3/4)	793 (31 1/4)	817 (32 3/16)	952 (37 1/2)	981 (38 5/8)	1270 (50)	1308 (51 1/2)
60P	762 (30)	784 (30 7/8)	952 (37 1/2)	981 (38 5/8)	1143 (45)	1177 (46 3/8)	1524 (60)	1568 (61 3/4)
70P	889 (35)	914 (36)	1111 (43 3/4)	1144 (45 1/16)	1333 (52 1/2)	1371 (54)	1778 (70)	1828 (72)
80P	1016 (40)	1047 (41 1/4)	1270 (50)	1308 (51 1/2)	1524 (60)	1568 (61 3/4)	2032 (80)	2095 (82 1/2)
90P	1143 (45)	1177 (46 3/8)	1428 (56 1/4)	1473 (58)	1714 (67 1/2)	1765 (69 1/2)	2286 (90)	2355 (92 3/4)
100P	1270 (50)	1308 (51 1/2)	1578 (62 1/2)	1635 (64 3/8)	1905 (75)	1962 (77 1/4)	2540 (100)	2616 (103)

<b>STANDARD ROLLER CHAIN SIZES (NEW CHAINS)</b>				
<b>Chain No.</b>	<b>150 Chain No.</b>	<b>Pitch mm (inches)</b>	<b>Width mm (inches)</b>	<b>Roller Diameter mm (inches)</b>
40	08A	12.7 (1/2)	7.9 (5/16)	7.9 (5/16)
50	10A	15.8 (5/8)	9.5 (3/8)	10.1 (.400)
60	12A	19 (3/4)	12.7 (1/2)	11.9 (15/32)
80	16A	25.4 (1)	15.8 (5/8)	15.8 (5/8)
100	20A	31.7 (1 1/4)	19 (3/4)	19 (3/4)
120	24A	38.1 (1 1/2)	25.4 (1)	22.2 (7/8)
140	28A	44.4 (1 3/4)	25.4 (1)	25.4 (1)
160	32A	50.8 (2)	31.7 (1 1/4)	28.5 (1 1/8)
180	*	57.1 (2 1/4)	35.7 (1 13/32)	35.7 (1 13/32)
200	40A	63.4 (2 1/2)	38.1 (1 1/2)	39.6 (1 9/16)

\*There is no No. 150 number.

**CONVERSION CHARTS**

	<b>foot</b>	<b>yard</b>	<b>mile</b>	<b>inch</b>	<b>meter</b>
<b>1 foot</b>	1	0.333	–	12	0.3048
<b>1 yard</b>	3	1	–	36	0.9144
<b>1 mile</b>	5280	1760	1	63360	1609.35
<b>1 inch</b>	0.0833	0.0277	–	1	0.0254
<b>1 meter</b>	3.281	1.0936	–	39.37	1

1 US bushel = 35.2391 liters

1 liter = 0.028 US bushel

1 US quart = 0.9464 liters

1 liter = 1.056 US quart

1 UK bushel = 36.3687 liters

1 liter = 0.027 UK bushel

1 UK quart = 1.1365 liters

1 liter = 0.879 UK quart

1 US gallon = 3.785 liters

1 liter = 0.264 US gallon

1 UK gallon = 4.5461 liters

1 liter = 0.22 UK gallon

1 barrel = 158.987 liters

1 liter = 0.0063 barrel

1 acre = 0.4047 ha

1 ha = 2.471 acres

1 pound = 0.4536 kg

1 kg = 2.204 pounds

1 hp = 0.736 kW

1 kW = 1.358 hp

1 lb/sq. in. = 0.0689 bar

1 bar = 14.5 lbs./sq. in.

**METRIC CUSTOMARY UNIT - EQUIVALENTS**

	<b>Multiply by:</b>	<b>To get:</b>	<b>Multiply by:</b>	<b>To get:</b>
<b>LINEAR</b>				
inches	X 25.40	= millimeters (mm)	X 0.03937	= inches
feet	X 0.3048	= meters (m)	X 3.281	= feet
yards	X 0.9144	= meters (m)	X 1.0936	= yards
miles	X 1.6093	= kilometers (km)	X 0.6214	= miles
inches	X 2.540	= centimeters (cm)	X 0.3937	= inches
microinches	X 0.0254	= micrometers (1µm)	X 39.37	= microinches

<b>AREA</b>				
inches <sup>2</sup>	X 645.16	= millimeters <sup>2</sup> (mm <sup>2</sup> )	X 0.00155	= inches <sup>2</sup>
inches <sup>2</sup>	X 6.452	= centimeters <sup>2</sup> (cm <sup>2</sup> )	X 0.155	= inches <sup>2</sup>
feet <sup>2</sup>	X 0.0929	= meters <sup>2</sup> (m <sup>2</sup> )	X 10.764	= feet <sup>2</sup>
yards <sup>2</sup>	X 0.8361	= meters <sup>2</sup> (m <sup>2</sup> )	X 1.196	= yards <sup>2</sup>
acres	X 0.4047	= hectares (10 <sup>4</sup> m <sup>2</sup> ) (ha)	X 2.471	= acres
miles <sup>2</sup>	X 2.590	= kilometers <sup>2</sup> (km <sup>2</sup> )	X 0.3861	= miles <sup>2</sup>

<b>VOLUME</b>				
inches <sup>3</sup>	X 16387	= millimeters <sup>3</sup> (mm <sup>3</sup> )	X 0.000061	= inches <sup>3</sup>
inches <sup>3</sup>	X 16.387	= centimeters <sup>3</sup> (cm <sup>3</sup> )	X 0.06102	= inches <sup>3</sup>
inches <sup>3</sup>	X 0.01639	= liters (L)	X 61.024	= inches <sup>3</sup>
quarts	X 0.94635	= liters (L)	X 1.0567	= quarts
gallons	X 3.7854	= liters (L)	X 0.2642	= gallons
feet <sup>3</sup>	X 28.317	= liters (L)	X 0.03531	= feet <sup>3</sup>
feet <sup>3</sup>	X 0.02832	= meters <sup>3</sup> (m <sup>3</sup> )	X 35.315	= feet <sup>3</sup>
fluid oz	X 29.57	= milliliters (mL)	X 0.03381	= fluid oz
yards <sup>3</sup>	X 0.7646	= meters <sup>3</sup> (m <sup>3</sup> )	X 1.3080	= yards <sup>3</sup>
teaspoons	X 4.929	= milliliters (mL)	X 0.2029	= teaspoon
cups	X 0.2366	= liters (L)	X 4.227	= cups

<b>MASS</b>				
ounces (av)	X 28.35	= grams (g)	X0.03527	= ounces (av)
pounds (av)	X 0.4536	= kilograms (kg)	X 2.2046	= pounds (av)
tons (2000 lb)	X 907.18	= kilograms (kg)	X 0.001102	= tons (2000)
tons (2000 lb)	X 0.90718	= metric tons (t)	X 1.1023	= tons (2000)

<b>FORCE</b>				
ounces-f	X 0.278	= newtons (N)	X 3.597	= ounces-f
pounds-f	X 4.448	= newtons (N)	X 0.2248	= pounds-f
kilograms-f	X 9.807	= newtons (N)	X 0.10197	= kilograms-f

**TEMPERATURE**

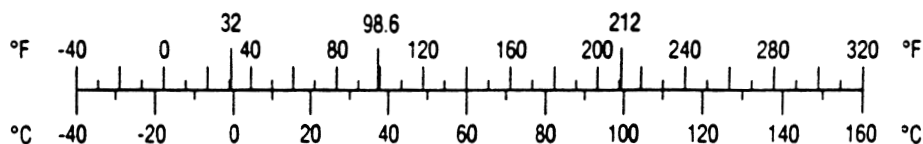

**SECTION 00 – GENERAL INFORMATION – CHAPTER 1**

---

<b>Multiply by: To get:</b>			<b>Multiply by: To get:</b>		
<b>ACCELERATION</b> (Standard gravity = 9.807 m/s <sup>2</sup> )					
feet/sec <sup>2</sup>	X 0.3048	= meters/sec <sup>2</sup> (m/s <sup>2</sup> )	X 3.281	= feet/sec <sup>2</sup>	
inches/sec <sup>2</sup>	X 0.0254	= meters/sec <sup>2</sup> (m/s <sup>2</sup> )	X 39.37	= inches/sec <sup>2</sup>	
<b>ENERGY OR WORK</b> (watt-second = joule = newton-meter)					
foot-pounds	X 1.3558	= joules (J)	X 0.7376	= foot-pounds	
calories (heat)	X 4.187	= joules (J)	X 0.2388	= calories (Int'l)	
Btu (Int'l)	X 1055	= joules (J)	X 0.000948	= Btu (Int'l)	
watt-hours	X 3600	= joules (J)	X 0.0002778	= watt-hours	
kilowatt-hrs	X 3.600	= megajoules (MJ)	X 0.2778	= kilowatt-hrs	
<b>FUEL ECONOMY AND FUEL CONSUMPTION</b>					
miles/gal	X 0.42514	= kilometers/liter(km/L)	X 2.3522	= miles/gal	
Note: 235.2 (mi/gai) = L/100 km and 235.2/(L/100 km) = mi/gal					
<b>LIGHT</b>					
footcandles	X 10.76	= lumens/meter <sup>2</sup> (lm/m <sup>2</sup> )	X 0.0929	= footcandles	
<b>PRESSURE OR STRESS</b> (newton/sq meter=pascal)					
inches Hg(60°F)	X 3.377	= kilopascal (kPa)	X 0.2961	= inches Hg	
pounds/sq in	X 6.895	= kilopascal (kPa)	X 0.145	= pounds/sq in.	
inches H <sub>2</sub> O (60°F)	X 0.2488	= kilopascal (kPa)	X 4.0193	= inches H <sup>2</sup> O	
bars	X 100	= kilopascal (kPa)	X 0.01	= bars	
pounds/sq ft	X 47.88	= pascals (Pa)	X 0.02088	= pounds/sq ft	
kgf/cm <sup>2</sup>	X 98.07	= kilopascals (kPa)	X 0.010197	= kgf/cm <sup>2</sup>	
<b>POWER</b>					
horsepower	X 0.746	= kilowatts (KW)	X 1.34	= horsepower	
ft-lbf/min	X 0.0226	= watts (W)	X 44.25	=ft-lbf/min	
<b>TORQUE</b>					
pound-inches	X 0.11298	= newton meters (N·m)	X 8.851	= pound-inches	
pound-feet	X 1.3558	= newton meters (N·m)	X 0.7376	= pound-feet	
kgf-cm	X 0.09807	= newton meters (N·m)	X 10.197	= kgf-cm	
kgf-m	X 9.807	= newton meters (N·m)	X 0.10197	= kgf-m	
<b>VELOCITY</b>					
miles/hour	X 1.6093	= kilometers/hour (km/h)	X 0.6214	= miles/hour	
feet/second	X 0.3048	= meters/sec (m/s)	X 3.281	= feet/sec	
kilometers/hr	X 0.27778	= meters/sec (m/s)	X 3.600	= kilometers/hr	
miles/hour	X 0.4470	= meters/sec (m/s)	X 2.237	= miles/hour	

Thank you so much for reading.  
Please click the “Buy Now!”  
button below to download the  
complete manual.



After you pay.

You can download the most  
perfect and complete manual in  
the world immediately.

Our support email:

[ebooklibonline@outlook.com](mailto:ebooklibonline@outlook.com)