

L103

L104

L105

L106

L107

L108

L795

Farm Loader

SERVICE MANUAL

Part number 60034449

1st edition English

March 2018

CASE II
AGRICULTURE

TABLE OF CONTENTS

1. INTRODUCTION..... 3

1.1. Necessary additional documentation.....	3
1.2. Identification.....	4
1.2.1. Model and serial number.....	4
1.3. Alignment reference.....	5
1.4. Setting joystick position.....	5
1.5. Subframe identification.....	6
1.6. Subframe identification DM/DL/DLM/DXL.....	7

2. DESCRIPTION AND DEFINITIONS..... 8

2.1. Description.....	8
2.2. Definitions.....	9
2.2.1. Third/fourth hydraulic function.....	9
2.2.2. Live3 (active third hydraulic function).....	9
2.2.3. Implement lock.....	9
2.2.3.1. Mechanical implement lock type Click-on.....	10
2.2.3.2. Hydraulic implement locking.....	10
2.2.4. Hydro Quick / Multi-coupler MC4.....	10
2.2.5. Single couplers.....	11
2.2.6. Multicoupler 2 (MC2).....	11
2.2.7. Lock & Go.....	11
2.2.8. Position indicator.....	12
2.2.9. Compact Valve Unit (CVU).....	12
2.2.10. Hydraulic implement connection, Multi-coupler.....	13
2.2.11. Hose kit.....	13
2.2.12. Soft Ride, Load Damping System.....	13
2.2.12.1. Electric shut-off, boom suspension.....	13
2.2.13. Material buckets.....	14
2.2.14. Heavy Duty Material Buckets.....	14
2.2.15. Construction Tooth Buckets.....	14
2.2.16. Light Material/ Snow Buckets.....	14
2.2.17. Fork Lifts.....	15
2.2.18. Log Grab Attachment for Fork Lifts.....	15
2.2.19. Bale spike.....	16
2.2.20. Big Bale Fork / with Backstop.....	16
2.2.21. Grapple with optional backscreen.....	17
2.2.22. Flexigrip 160, 200.....	17
2.2.23. Quadrogrip 200.....	18
2.2.24. Weld on Hook Set.....	18
2.2.25. Systems DM, DL and DXL.....	19
2.2.26. Mechanical Self Levelling loader, MSL.....	19
2.2.27. Non-Self Levelling loader, NSL.....	19
2.2.28. Tool carrier.....	20
2.2.29. Implement.....	20
2.2.30. Implement hooks.....	20
2.2.30.1. Identification, Skidsteer implement.....	20
2.2.30.2. Identification, Euro implement.....	21

3. SAFETY INSTRUCTIONS.....22

3.1. General information.....	22
3.1.1. Guards.....	22
3.1.2. Warning, prohibition and information decals.....	22
3.2. Explanation of warning levels.....	22
3.2.1. Symbol explanation.....	23
3.2.2. Responsibility.....	24
3.3. Installing the loader.....	24
3.4. Joystick operation.....	26
3.5. Protection equipment.....	26
3.5.1. Service.....	26

3.5.2. Welding.....	26
3.5.3. Safety belt.....	27
3.5.4. ROPS, Rollover protection structure.....	27
3.6. Operation.....	27
3.6.1. Before work.....	27
3.6.2. Operator/driver location.....	28
3.6.3. Connecting implement.....	28
3.6.3.1. Manual implement lock.....	28
3.6.3.2. Hydraulic implement lock.....	29
3.6.4. Workplace.....	29
3.6.5. Stability.....	31
3.6.5.1. Load stability.....	31
3.6.6. Tractor stability.....	31
3.7. Risk factors.....	32
3.7.1. During transport and work.....	32
3.7.2. During service.....	34
3.7.3. After work.....	35
3.8. Replacement parts.....	36
3.9. Location of warning, prohibition and information decals (EU).....	37
3.10. Location of warning, prohibition and information decals (NAFTA).....	38
3.11. Location of safety signs on implements.....	39

4. INSTALLATION - SUBFRAME..... 41

4.1. Installation preparation - subframe.....	41
4.2. Installation – subframe on tractor.....	42
4.3. Installation checks – subframe installation.....	42

5. INSTALLATION – FRONT LOADERS..... 43

5.1. Installation Preparation, Front Loaders.....	43
5.1.1. Lock & Go.....	43
5.1.2. Position indicator.....	43
5.1.2.1. Position indicator setting.....	43
5.2. Connection – Front loader with subframe.....	44
5.2.1. Connecting the loader using lifting equipment.....	44
5.2.2. Coupling a parked loader.....	47
5.3. Checking front loader installation.....	49
5.4. Disconnecting-Front loader with subframe.....	51
5.4.1. Unhitching the loader using lifting equipment.....	51
5.4.2. Disconnecting the loader.....	53

6. INSTALLATION – CONTROL SYSTEM..... 55

6.1. Hose kit.....	55
6.2. Compact Valve Unit, CVU.....	55
6.2.1. CVU equipped with: Basic NSL (no extra functions).....	55
6.2.2. CVU equipped with: Soft Ride + shock valves (tilt).....	56
6.2.3. CVU equipped with: Third hydraulic function.....	56
6.2.4. CVU equipped with: Third function + Soft Ride.....	56
6.2.5. CVU equipped with: Third function + hydraulic implement lock.....	57
6.2.6. CVU equipped with: Third function + Soft Ride + hydraulic implement lock.....	57

6.2.7. CVU equipped with: Third and fourth hydraulic functions.....	58	11.1.9. Installing the top nut, piston and bottom guide on the piston rod.....	87
6.2.8. CVU equipped with: Live3.....	58	11.1.10. Final assembly - tilt cylinder.....	87
6.2.9. CVU equipped with: Live3 + Soft Ride + shock valves (tilt).....	59	11.2. Tilt cylinder - Non-Self Levelling loader (NSL).....	90
6.2.10. CVU equipped with: Live3 + hydraulic implement lock.....	59	11.2.1. Tilt cylinder disassembly.....	90
6.2.11. CVU equipped with: Live3 + Soft Ride + hydraulic implement lock.....	60	11.2.2. Removing the piston.....	92
7. SERVICE - GENERAL.....	61	11.2.3. Remove the piston seals.....	93
7.0.12. The tractor's own joystick.....	61	11.2.4. Remove the top nut seals.....	93
8. SERVICE - SUBFRAME.....	62	11.2.5. Installing new sealing components on the piston.....	93
9. SERVICE - FRONT LOADERS.....	63	11.2.6. Installing new sealing components on the top nut.....	93
9.1. Lubrication.....	63	11.2.7. Installing the bearing and the piston on the piston rod.....	94
9.2. Tool carrier.....	63	11.2.8. Final assembly - tilt cylinder.....	95
9.3. Loaders.....	64	11.3. Lift cylinder.....	97
9.3.1. Pins and bushings.....	64	11.3.1. Tilt cylinder disassembly.....	97
9.3.1.1. Bushing.....	64	11.3.2. Removing the piston.....	99
9.3.2. Tool carrier, replacing pins and bushings.....	64	11.3.3. Remove the piston seals.....	100
9.3.3. Replacing the pins and bushings, triangular link.....	66	11.3.4. Remove the top nut seals.....	100
9.3.4. Replacing pins and bushings, lift cylinder and bearing box.....	66	11.3.5. Installing new sealing components on the piston.....	100
9.4. Bearing box.....	68	11.3.6. Installing new sealing components on the top nut.....	100
10. SERVICE - LOADER HYDRAULICS.....	69	11.3.7. Installing the bearing and the piston on the piston rod.....	101
10.1. Hydraulic system.....	69	11.3.8. Final assembly - lift cylinder.....	102
10.2. Hoses and connectors.....	69	12. TROUBLESHOOTING.....	104
10.2.1. Replacing hoses or connectors.....	70	12.1. Troubleshooting table - loaders.....	104
10.3. Main hose kit.....	70	12.1.1. CVU.....	107
10.4. Boom suspension.....	72	13. TIGHTENING TORQUES.....	109
10.4.1. Replacing accumulators.....	72	13.1. Tightening torques.....	109
10.5. Compact Valve Unit (CVU) with associated function modules.....	75	13.1.1. Table - Tightening torque.....	109
10.5.1. Module CB01 connecting block "Basic".....	76	14. STORAGE.....	110
10.5.2. Module CB03 connecting block "Soft Ride".....	77	15. SPECIFICATIONS.....	111
10.5.3. Module CB04 connecting block "Tilt".....	77	15.1. Mechanical self levelling, MSL.....	112
10.5.4. Module SV01 selector valve Third hydraulic function.....	78	15.2. Non self levelling, NSL.....	115
10.5.5. Module SV02 selector valve fourth hydraulic function.....	79	16. WIRING DIAGRAM.....	117
10.5.6. Module IL01 Hydraulic lock valve.....	80	16.1. Wiring diagram - Loader.....	117
11. SERVICE - CYLINDERS.....	81	16.2. Wiring diagram -Loader with Live3.....	118
11.1. Tilt cylinder - Mechanical Self Levelling loader, (MSL).....	81	16.3. Wiring diagram - Loader with all hydraulic functions.....	119
11.1.1. Tilt cylinder disassembly.....	81		
11.1.2. Removing the piston.....	84		
11.1.3. Remove the piston seals.....	84		
11.1.4. Remove the top nut seals.....	85		
11.1.5. Remove the bottom guide seals.....	85		
11.1.6. Installing new sealing components on the piston.....	85		
11.1.7. Installing new sealing components on the top nut.....	85		
11.1.8. Installing new sealing components on the bottom guide.....	86		

1. INTRODUCTION

WARNING:

Careless or incorrect use of the loader/implement may result in serious injury or death for the driver or others. Observe the safety instructions.

This service manual describes commissioning, servicing, repairs and troubleshooting on agricultural loaders used in combination with front loaders manufactured by Ålö AB. The information in the service manual was correct when the manual went to press. Contact Ålö AB if there is anything in the manual you do not understand.

Read and study the text in the **service manual** before commissioning, servicing or repairing the front loader. If you are not an experienced service technician, study the service manual and ask experienced service technicians to explain things to you. Keep this **service manual** within easy reach. Replace the service manual if the old one is damaged or lost.

Read and study the text in the user manuals for the loader, the control system and the tractor thoroughly before using the equipment. If you are not an experienced operator, study the user manual and ask experienced operators to explain things to you.

This machine is designed with simple service in mind, and it can be maintained with regular hand tools.

WARNING:

Read through the entire service manual before you begin using the product.

We reserve the right to introduce changes to the design and specification, or improvements at any time, without prior notice or commitment.

IMPORTANT: The loader and loader subframe combination is designed for a specific tractor model. Do not install a subframe on another model of tractor without permission from the manufacturer.

No Installation Instructions, operating instructions or service instructions for implements are included in this service manual. Use the publications supplied with each implement.

1.1. Necessary additional documentation

To perform the work described in this service manual properly, the following documentation is required:

- User manual, front loader
- User manual, tractor
- Service and repair manual, tractor
- Technical specifications, tractor

IMPORTANT: Some, but NOT all, information in this service manual is taken from the above mentioned manuals. Read all manuals and technical specifications carefully to ensure proper start-up, maintenance and/or repair of the loader and control system.

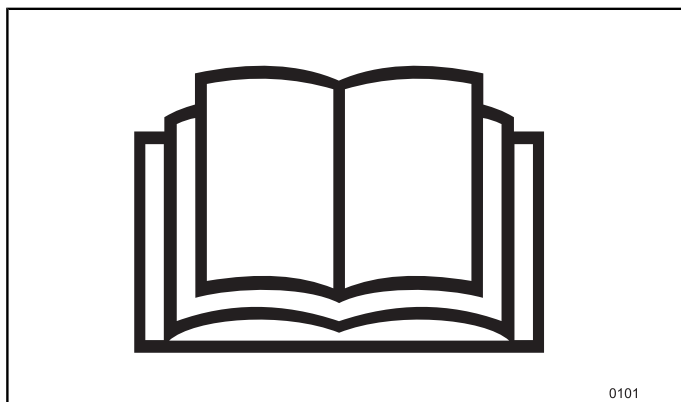

Fig. 1 Read through the entire service manual before you begin using the product.

1.2. Identification

1.2.1. Model and serial number

Each loader has an identification plate (A) with an identification number. The plate is located on the inside of the left arm.

The plate specifies:

- Product: Machine name
- Type: Type/model
- Made by: Complete address of manufacturer and country of manufacture.
- Ref. No.: Reference number for loader
- Serial No.: Serial number for loader
- Date: Date of manufacture
- Weight: Loader weight without implements, according to the factory delivery specification.

The type (A), serial number (B) and date of manufacture (C) must always be quoted during service questions or when spare parts are needed.

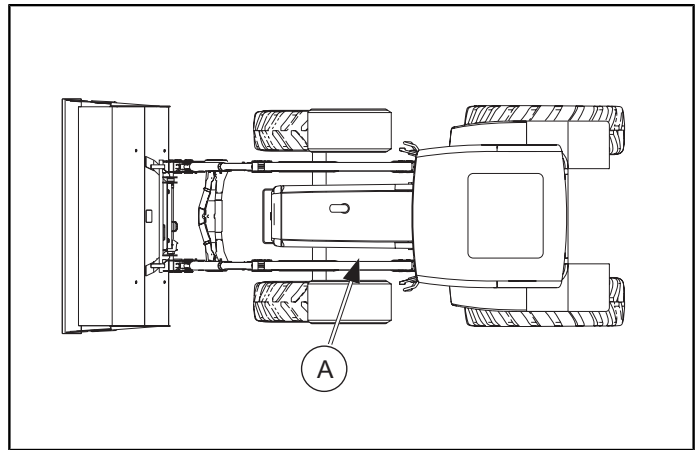

Fig. 2 Location of identification plate.

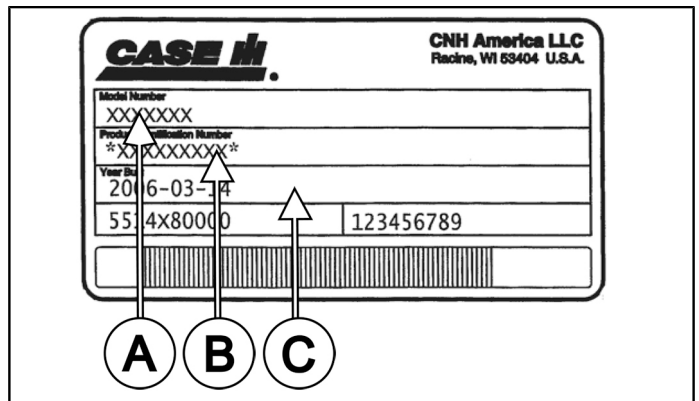

Fig. 3 Machine sign.

The subframe, accessories, cylinder, valve, control cables and hoses are fitted with type plates or stamped/printed part number.

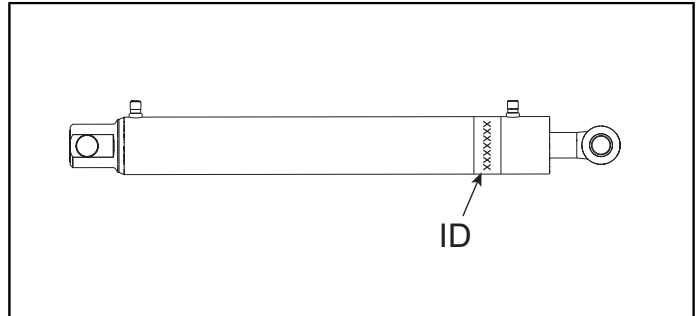

Fig. 4 Marking of components, e.g., cylinder.

When ordering control cables, specify the length (L) and ID.

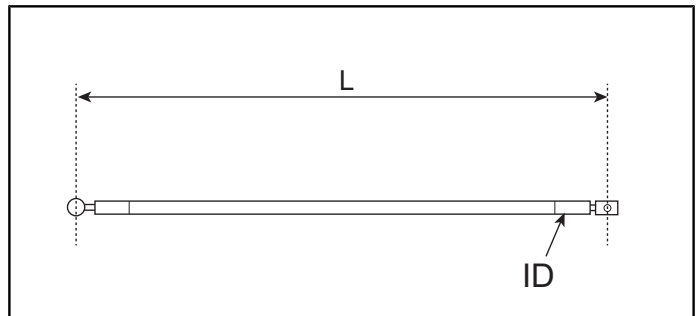

Fig. 5 Indicate length when ordering control cable.

1.3. Alignment reference

Throughout this service manual, reference is made to the left (A) and right (B) as seen from the operator's seat looking forward with the operating levers to the right of the operator.

NOTE: Some illustrations in this service manual may show a different model of tractor or loader, compared with your loader. The same information applies to your equipment unless otherwise specified.

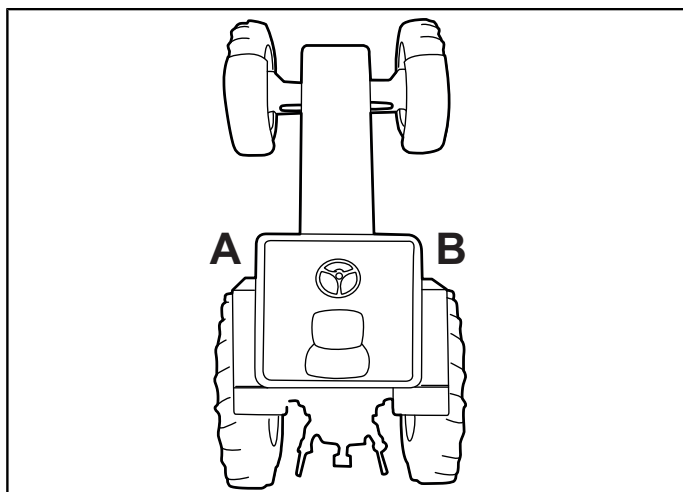
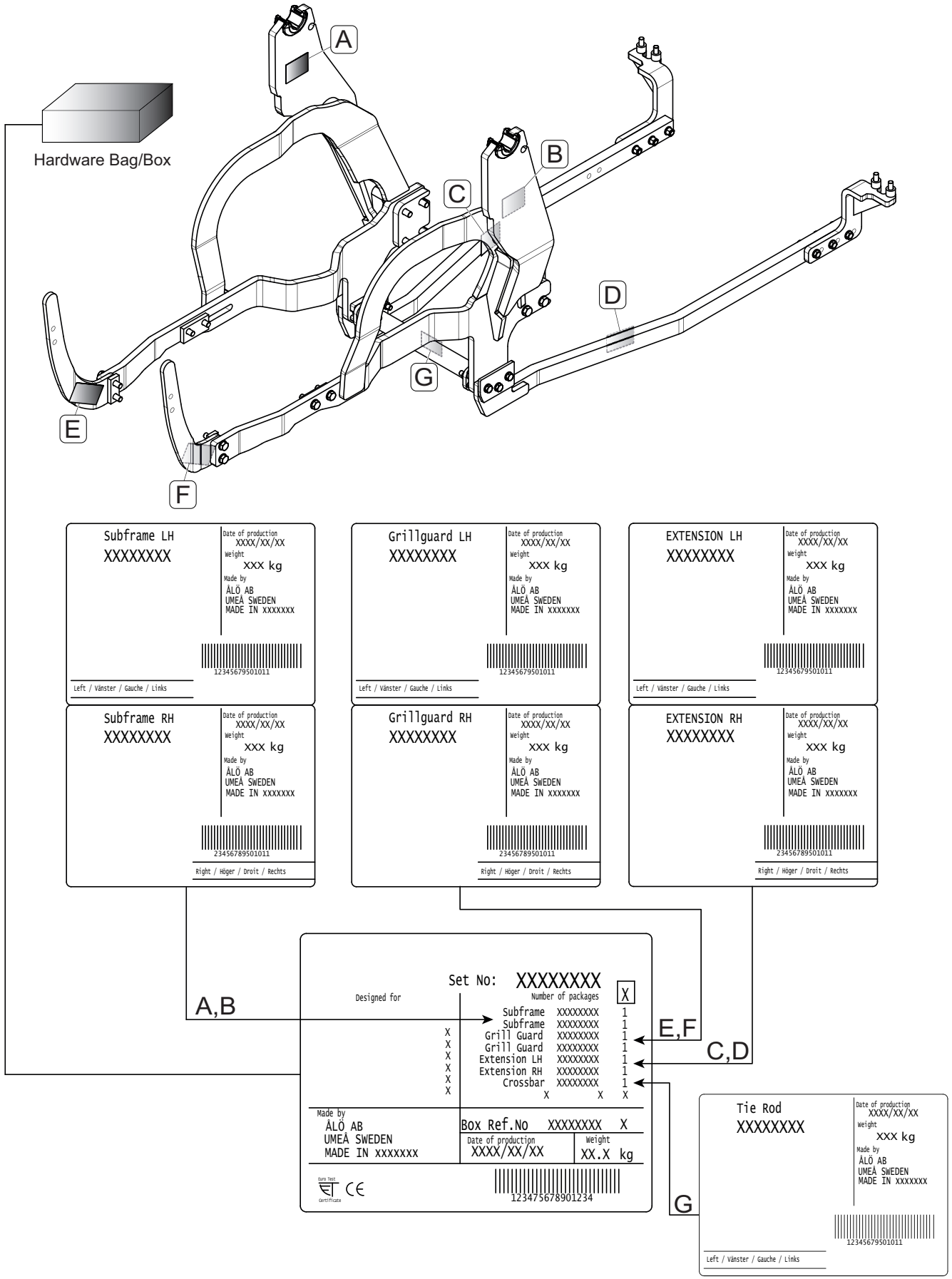

Fig. 6 Alignment reference

1.4. Setting joystick position

IMPORTANT: Adjust the joystick to achieve an ergonomic position.

1.5. Subframe identification



1.6. Subframe identification DM/DL/DLM/DXL

C/C = distance between loader arms. Available in the following widths:

DM - c/c distance = 1040 mm.

DL/DLM - c/c distance = 1200 mm.

DXL - c/c distance = 1420 mm.

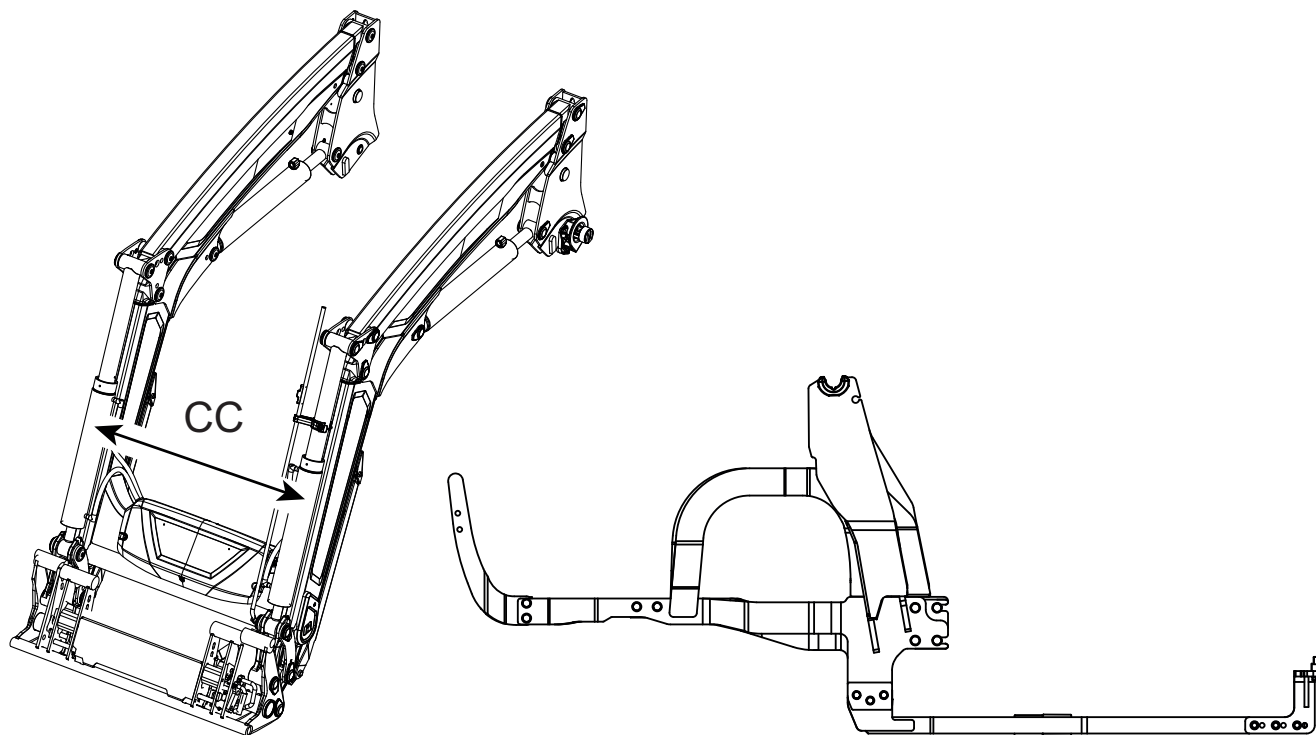
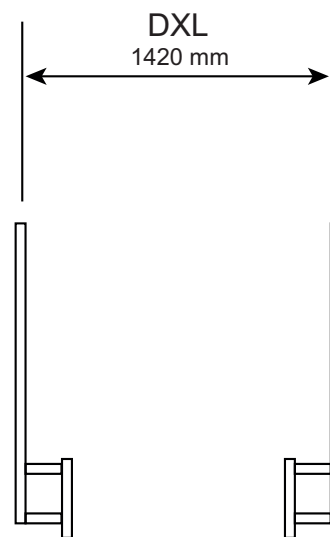
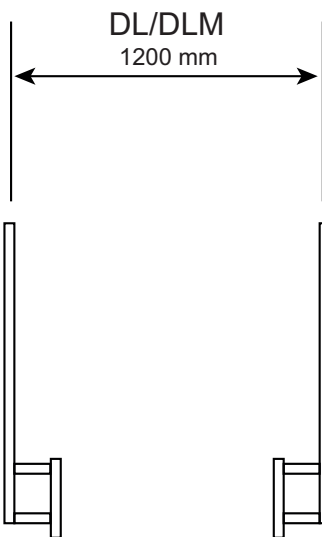
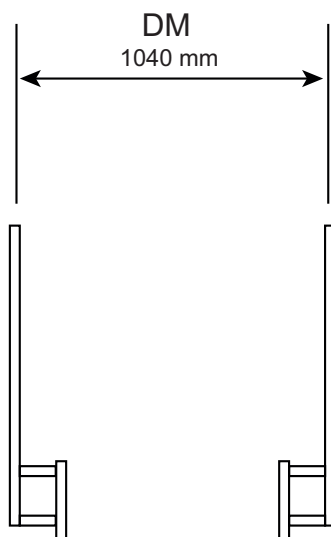

2. DESCRIPTION AND DEFINITIONS

Not all accessories fit all loaders. Please contact your dealer for information on compatibility with your loader.

Not all accessories are available in all markets.

2.1. Description

The front loader is adjusted to:

- be installed on wheel-bound agricultural and forestry tractors.
- Handle various certified implements for lifting, carrying, cutting, scraping, grading, sweeping and plowing.



WARNING:

Risk of overturning; risk of crush and pinch injuries. Should any loader hose rupture, the loader, implement or load may drop uncontrollably. If a hose ruptures, correct the error immediately as per section 7. *Service - general*. When replacing parts, only use original spare parts to restore the machine to its original specifications. Decontaminate the soil in accordance with standards/laws applicable in the country or region you are in.

IMPORTANT: Faults in the power supply to the loader's electrical and/or hydraulic systems may mean that certain functions cannot be activated. For example: Raising the loader, opening the implement, third and fourth hydraulic functions etc.

2.2. Definitions

2.2.1. Third/fourth hydraulic function

The loader can be equipped with a third hydraulic function (1) and a fourth hydraulic function (2) for operating hydraulic implements.

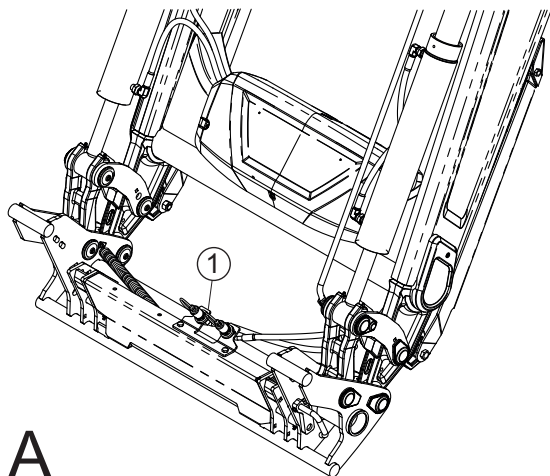

A

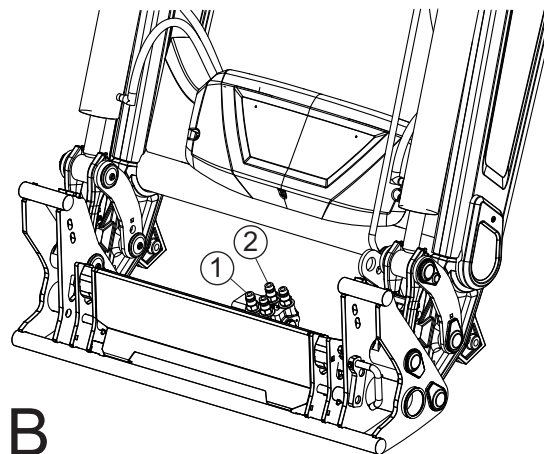

B

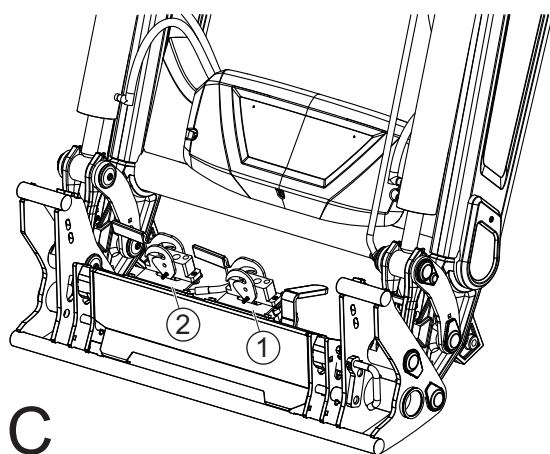

C

A Example: Third hydraulic function

B Example: Third and fourth hydraulic function

C Example: Third and fourth hydraulic functions with Selectofix

2.2.2. Live3 (active third hydraulic function)

The loader can be equipped with Live3.

Live3 is an active third hydraulic function that allows operation of the loader and the hydraulic implement simultaneously.

NOTE: Live3 will be supplied by the tractor if equipped.

2.2.3. Implement lock

The loader is equipped with a mechanical or hydraulic implement lock.

2.2.3.1. Mechanical implement lock type Click-on

Automatic implement locking upon connection.
Manual implement unlocking upon disconnection.

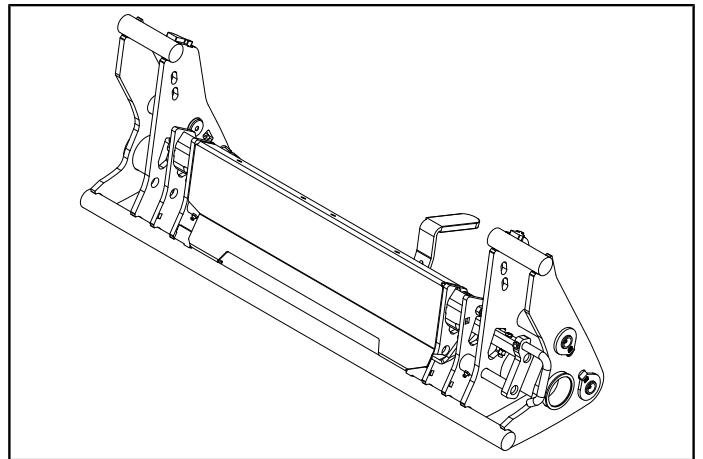

Fig. 7 Mechanical implement lock type Click-on

2.2.3.2. Hydraulic implement locking

Hydraulic implement locking upon connection.
Hydraulic implement unlocking upon disconnection.

Locking and unlocking via a joystick in the operator's position.

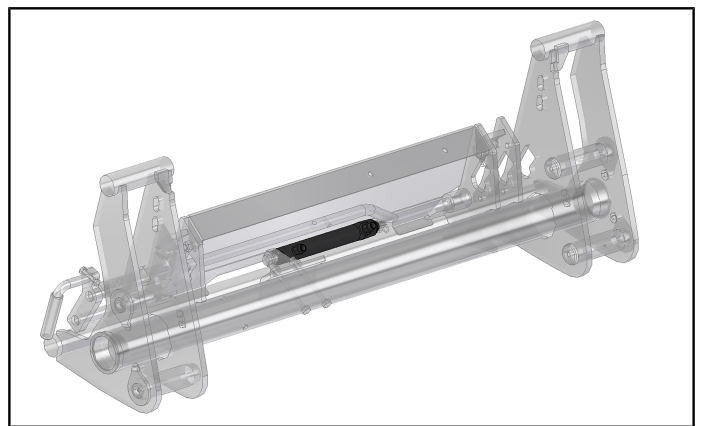

Fig. 8 Illustrations: Hydraulic implement locking

2.2.4. Hydro Quick / Multi-coupler MC4

Multi-couplers facilitate connection and disconnection of the loader hydraulics to the control valve. The risk of incorrect connection and oil spills is eliminated.

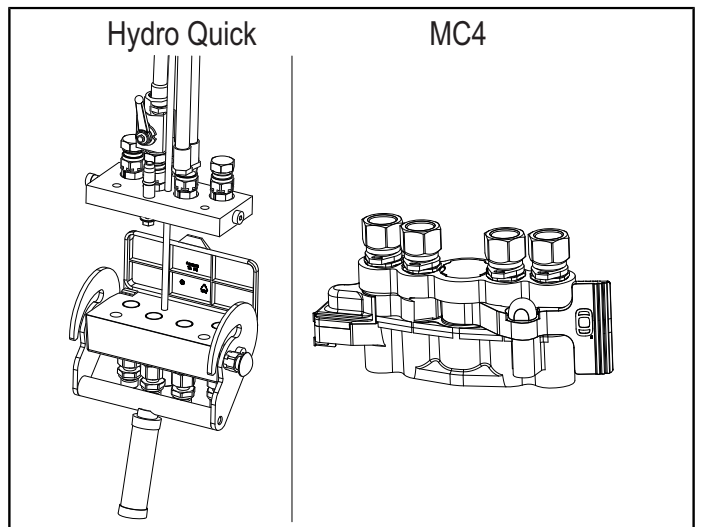

Fig. 9 Multi coupling: Hydro Quick / Multi coupling MC4

2.2.5. Single couplers

Connection and disconnection of the loader's hydraulics to the control valve using single ISO-A couplers (ISO7241 1/2") or flat face couplers (ISO16028 3/8").

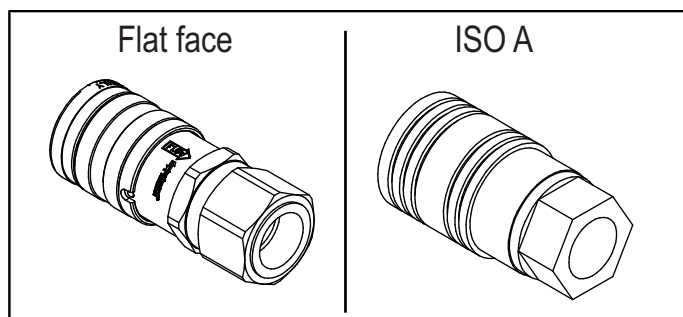

Fig. 10 Single couplers: Flat face / ISO A

2.2.6. Multicoupler 2 (MC2)

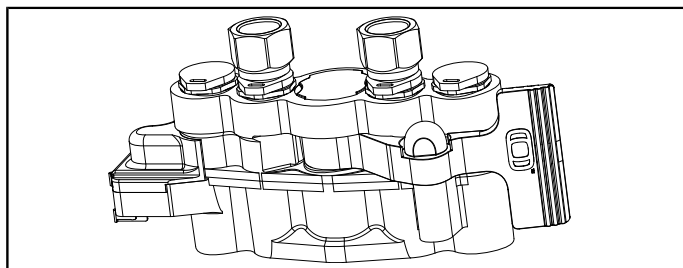

Fig. 11 Multicoupler 2 (MC2)

2.2.7. Lock & Go

Automatic coupling between loader and subframe.

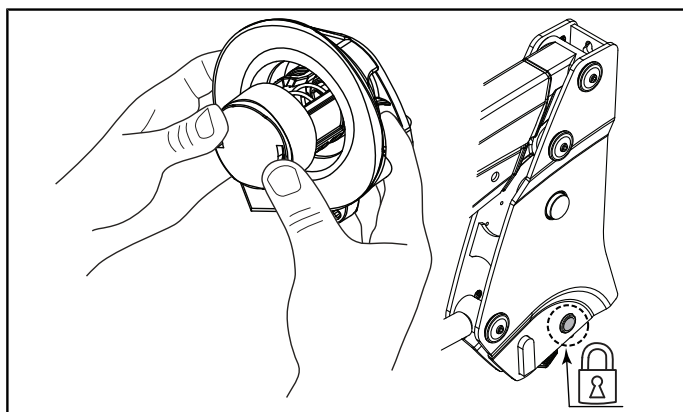

Fig. 12 Lock & Go, green indicator shows loader is locked to subframe.

2.2.8. Position indicator

The indicator shows the implement angle relative at the ground level.

The indicator can be adjusted as necessary, depending on the implement in use or the desired indication angle.

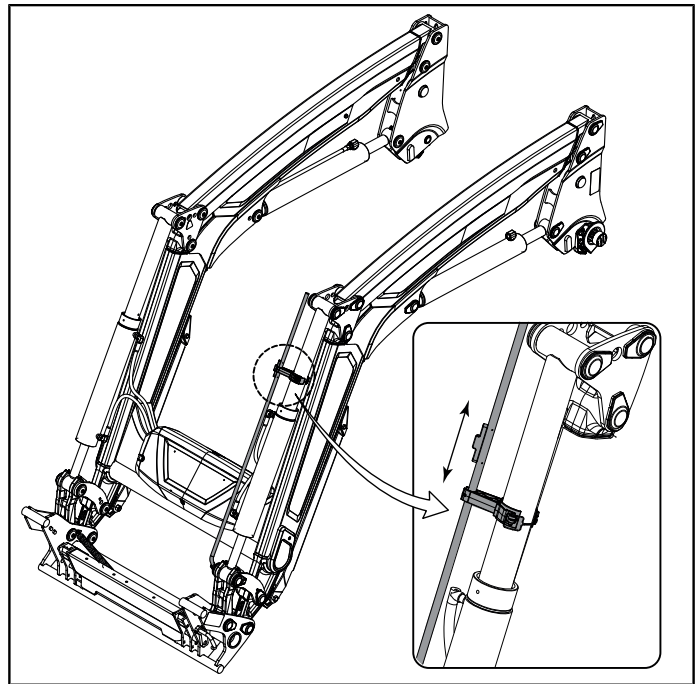

Fig. 13 Position indicator

2.2.9. Compact Valve Unit (CVU)

Loader diverting valve. The valve distributes hydraulic fluid for raising/lowering, opening/emptying, 3rd/4th hydraulic functions, boom suspension and the hydraulic implement lock.

Compact Valve Unit (CVU):

- Integrated shock valve to protect the implement cylinder (tilt).
- Third hydraulic service module.
- Fourth hydraulic service module.

3rd service must be installed to be able to use the 4th service.

- Hydraulic lock module

3rd service or Live3 must be installed to be able to use the hydraulic lock

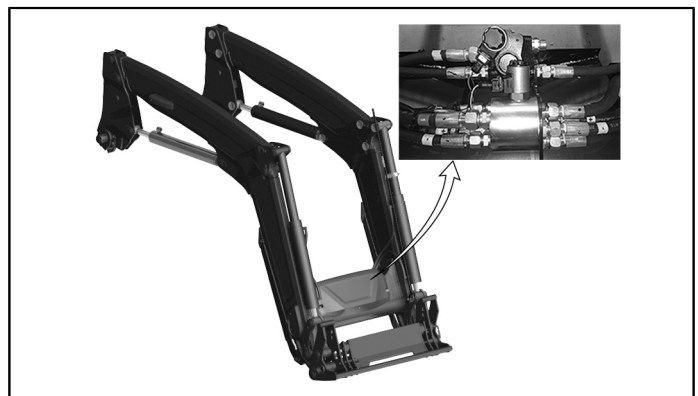

Fig. 14 Diverting valve, Compact Valve Unit (CVU)

2.2.10. Hydraulic implement connection, Multi-coupler

Facilitates connection and disconnection of implement hydraulics to the third and fourth hydraulic functions. The Multi-coupler eliminates the risk of incorrect connection and oil spillage.

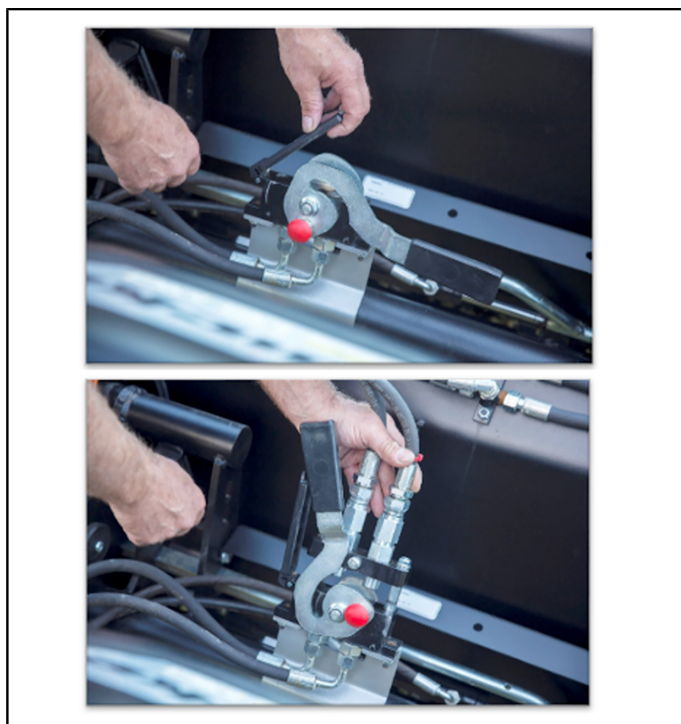

Fig. 15 Hydraulic implement connection

2.2.11. Hose kit

Hoses and hydraulic components for connecting the loader to the tractor's own control valve.

2.2.12. Soft Ride, Load Damping System

Improves operator comfort.

Secures the load; reduces the risk of the load falling from the implement.

Reduces stress on the tractor and loader when driving on rough surfaces.

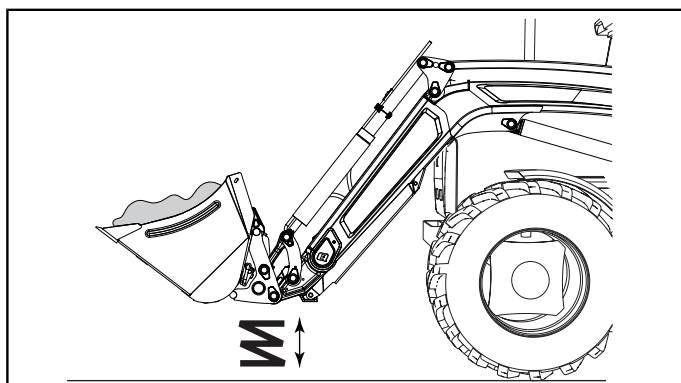

Fig. 16 Load Damping System

2.2.12.1. Electric shut-off, boom suspension

Joystick button to activate or deactivate the loader's boom suspension function.

If the loader is controlled using the tractor's own joystick, there may be a separate button that activates/deactivates the boom suspension function.

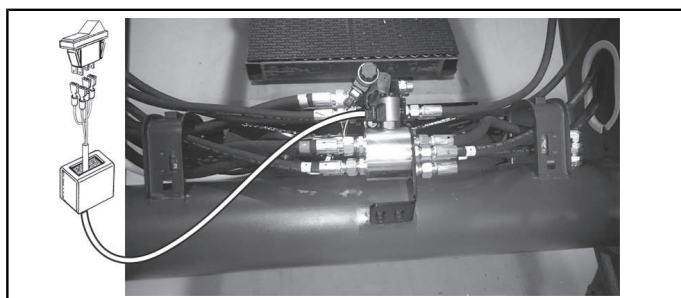

Fig. 17 Electric shut-off, load damping function.

2.2.13. Material buckets

63" (160 cm), 73" (185 cm), 83" (210 cm), 95" (240 cm)



Fig. 18 Material buckets

2.2.14. Heavy Duty Material Buckets

73" (185 cm), 83" (210 cm), 95" (240 cm), 102" (260 cm)



Fig. 19 Heavy Duty Material Buckets

2.2.15. Construction Tooth Buckets

63" (160 cm), 73" (185 cm), 83" (210 cm)

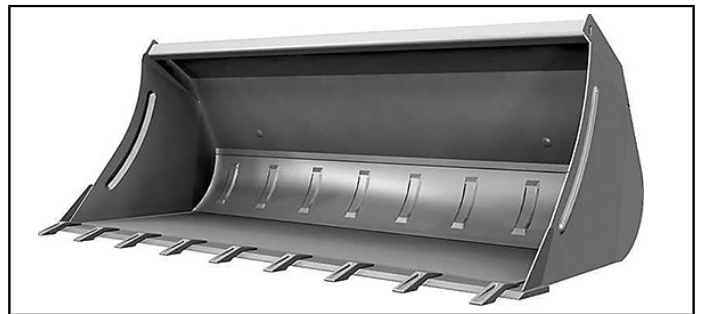

Fig. 20 Construction Tooth Buckets

2.2.16. Light Material/ Snow Buckets

79" (200 cm), 83" (210 cm), 87" (220 cm), 95" (240 cm), 102" (260 cm)

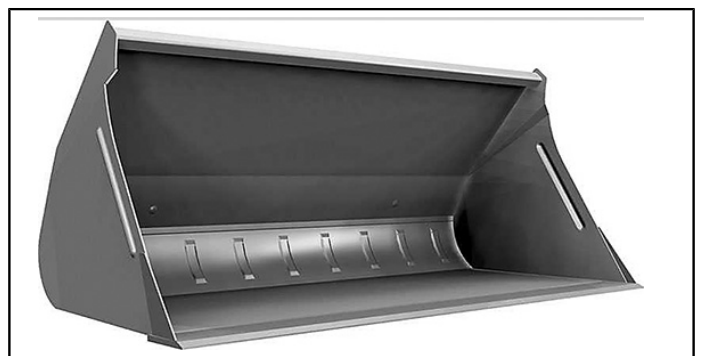

Fig. 21 Light Material/ Snow Buckets

Thank you so much for reading.
Please click the “Buy Now!”
button below to download the
complete manual.



After you pay.

You can download the most
perfect and complete manual in
the world immediately.

Our support email:

ebooklibonline@outlook.com