

# Workshop Service Manual

# Technician Service Book -

# MF 5600

GBA25  
GBA50  
GPA50

Electrical and hydraulics diagrams

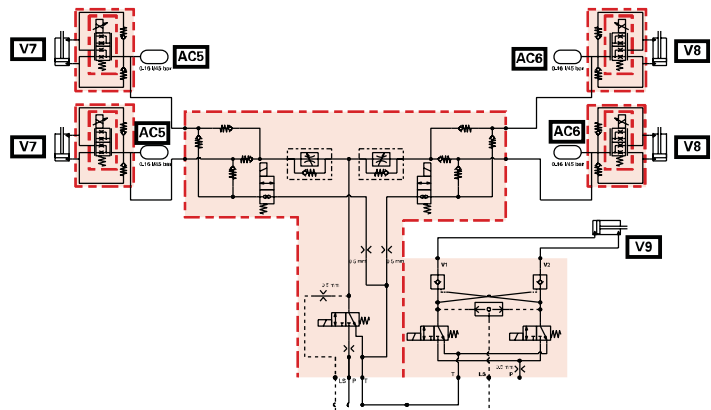
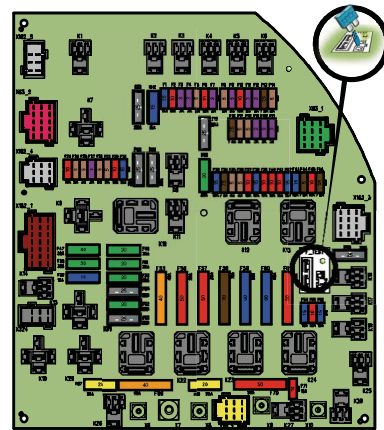

# Technician Service Book - MF 5600

- 1 General
  - A General specifications
  - B Forward speeds
  - C GTA5050 transmission dimensions and attachment points
  - D GTA2550 transmission dimensions and attachment points
  - E GTA5050 transmission capacities
  - G Tightening torques, retaining compounds and sealing products
- 2 Error codes
  - A Indicator light panel
  - B Error codes
- 3 Fuse box, electrical diagrams, harnesses, hydraulics diagrams and pneumatic diagrams
  - A Fuse box, electrical diagrams and harnesses
  - B Hydraulics diagrams
  - C Pneumatic diagrams
- 4 Adjustments, bleeding and calibrations
  - A Bleeding
  - B Calibrations



# 1 - General

A	General specifications .....	3
B	Forward speeds .....	29
C	GTA5050 transmission dimensions and attachment points.....	37
D	GTA2550 transmission dimensions and attachment points.....	43
E	GTA5050 transmission capacities.....	51
G	Tightening torques, retaining compounds and sealing products .....	55



## A - General specifications

1	MF 5608 model .....	5
2	Model MF 5609 .....	9
3	Model MF 5610 .....	13
4	MF 5611 model .....	17
5	MF 5612 model .....	21
6	MF 5613 model .....	25



# 1 MF 5608 model

Engine	
Brand	AGCO Power
Type	33 AWI
Maximum power hp (kW) (ISO TR14396) at 2000 rpm	86.3 (63.5)
Maximum torque (ISO TR14396)	363 Nm (268 lbf ft)
Maximum PTO power hp (kW) (OECD) at PTO 1000 rpm	-
Idle speed	720/850 rpm
Maximum speed	2260 rpm
Engine weight	350 kg (772 lb)
Number of cylinders	3
Engine cubic capacity	3,3 l (0.9 gal (US))
Piston travel	120 mm (4.7 in)
Piston diameter	108 mm (4.3 in)
Compression ratio	17.4:1
Compression pressure	-
Injection pump brand	Bosch
Injection pump type	Common rail CP4.1
Firing order	1-2-3
Fuel prefilter filtration capacity	10 μ
Main fuel filter filtration capacity	5 μ
Recommended oil:	CJ-4 or ACEA-E9
Lubrication system	By gear pump
Oil cooling system	Oil/water heat exchanger
Oil pressure at minimum speed	1 bar (15 psi)
Oil pressure at maximum speed	2,5 bar (36 psi) at 5 bar (73 psi) depending on the temperature
Relief valve adjustment pressure	5 bar (73 psi) (spring pressure)
Air suction type	Turbo air/air
Air preheating type	Grid Heater
Number of valves	4 per cylinder = 12
Inlet valve clearance value	0,35 mm (0.01 in) ± 0,05 mm (0.002 in)
Exhaust valve clearance value	0,35 mm (0.01 in) ± 0,05 mm (0.002 in)
Engine cooling system	Coolant
Fan type	Viscostatic
Thermostat begins to open at	83 °C (181 °F)
Liquid temperature from - to +	-35 °C (-31 °F) to 106 °C (223 °F)
Block preheater	110 or 220 volts
Fuel preheater	Not available

Rear axle transmission	
Gearbox type	GBA50
Transmission type	Dyna-4
Number of gears	16 gears



Rear axle transmission	
Maximum speed	40 km/h (25 mile/h)
Number of super creeper gears	32
Rear axle type	GPA52
Final drive type	GPA52
Main brake type	Multidisc ball ramp
Parking brake type	Hand brake on main brakes
Trailer brake type	Hydraulics
Hydraulic trailer braking pressure	0 to 150 bar (2176 psi)
Maximum operating tilt - pitch (front/rear)	25°
Maximum operating tilt - roll (right/left)	22°
Maximum operating tilt - combined	22°
Transmission preheater	Accessory kit available

Four-wheel drive front axle	
Front axle brand	DANA
Axle type	Fixed
Supplier reference - fixed front axle	725/154
Supplier reference - suspended front axle	-
Rotational direction	Anti-clockwise
Recommended oil type (beam and final drive)	SAE85W90 (API GL4-MIL L-2105)
Total ratio for front axle	12.462
Oscillation angle	± 9°
Type of oscillation stop	Mechanical
Steering ram diameter	36 mm (1.4 in) x 65 mm (2.6 in)
Steering ram stroke	2 x 105 mm (4.1 in)
Factor K	1.382

Two-wheel drive front axle	
Front axle brand	LODI 140 CP

Electrohydraulic	
System type	Open centre
Flow rate	57 l/min (15.1 gal/min (US)) or 100 l/min (26.4 gal/min (US))
High-pressure pump type	Gear pump(s)
Maximum pump pressure	200 bar (2901 psi)
Maximum quantity of oil to add for heavy implements	25 l (6.6 gal (US))
Maximum exportable oil quantity (without adding oil)	16 l (4.2 gal (US)) with a droop of 10%
Maximum exportable oil quantity (adding oil)	41 l (10.8 gal (US)) with a droop of 10%
Number of spool valves (maximum)	4
Spool valve control type	Mechanical
Recommended oil:	According to MF CMS M1145 specification

Steering	
Steering type	Hydrostatic
Type of control	Steering wheel
2-wheel drive Orbitrol displacement	80 cm <sup>3</sup> (4.88 in <sup>3</sup> )
4-wheel drive Orbitrol displacement	125 cm <sup>3</sup> (7.63 in <sup>3</sup> )
Steering ram diameter	36 mm (1.4 in) x 65 mm (2.6 in)
Steering ram stroke	2 x 105 mm (4.1 in)
Working pressure	175 bar (2538 psi) ± 5 bar (73 psi)
Pressure relief valve adjustment pressure	175 bar (2538 psi) ± 5 bar (73 psi)
Shock valve adjustment pressure	225 bar (3263 psi) to 245 bar (3553 psi)
Oil recommended for steering	According to MF CMS M1145 specification

Rear linkage	
Lift ram diameter	75 mm (3.0 in)
Maximum lifting capacity at ball joints	3330 kg (7341 lb)
Working pressure	180 bar (2611 psi)
3-point linkage category	2

Front linkage	
Lift ram diameter	80 mm (3.2 in) / 40 mm (1.6 in)
Maximum lifting capacity at ball joints	2236 kg (4929 lb)
Working pressure	190 bar (2756 psi)
3-point linkage category	2

Rear power take-off (PTO)	
Number of selections possible for rear PTO	540 540/540ECO 540/540ECO/1000
Rotational direction	Clockwise
Clutch type	Multidisc hydraulic
Control pressure	21 bar (305 psi)
Splined shaft type	6 or 21 x 1 <sup>3</sup> / <sub>8</sub> (diameter 35 mm (1.4 in)) splines or 20 x 1 <sup>3</sup> / <sub>4</sub> (diameter 45 mm (1.8 in)) splines

Front power take-off	
Number of selections possible for front PTO	1000 rpm
Rotational direction	Anti-clockwise
Clutch type	Multidisc hydraulic
Splined shaft type	6 or 21 x 1 <sup>3</sup> / <sub>8</sub> (diameter 35 mm (1.4 in)) splines

Electric	
Battery brand	TAB
Battery specifications	12 V - 105 A/H
Starter type	12 Volts
Alternator type	14 V/120 A

Electronics	
Function of each controller	
Autotronic 5	Transmission
Autotronic 5	Cab
Autotronic 5	Linkage

Cab and fittings	
Type of cab suspension available	Fixed low Fixed high Mechanical suspended high
Type of rear-view mirror control available	Manual
Type of air conditioning control available	Manual
Type and brand of air conditioning compressor	SANDEN with axial pistons
Compressor displacement	154.9 cm <sup>3</sup> /rev
Refrigerant	R134a
Cab noise level	71 DBA
Roof type	Standard High-visibility Slimline

## 2 Model MF 5609

Engine	
Brand	AGCO Power
Type	33 AWI
Maximum power hp (kW) (ISO TR14396) at 2000 rpm	96.5 (71.0)
Maximum torque (ISO TR14396)	413 Nm (305 lbf ft)
Maximum PTO power hp (kW) (OECD) at PTO 1000 rpm	-
Idle speed	720/850 rpm
Maximum speed	2260 rpm
Engine weight	350 kg (772 lb)
Number of cylinders	3
Engine cubic capacity	3,3 l (0.9 gal (US))
Piston travel	120 mm (4.7 in)
Piston diameter	108 mm (4.3 in)
Compression ratio	17.4:1
Compression pressure	-
Injection pump brand	Bosch
Injection pump type	Common rail CP4.1
Firing order	1-2-3
Fuel prefilter filtration capacity	10 µ
Main fuel filter filtration capacity	5 µ
Recommended oil:	CJ-4 or ACEA-E9
Lubrication system	By gear pump
Oil cooling system	Oil/water heat exchanger
Oil pressure at minimum speed	1 bar (15 psi)
Oil pressure at maximum speed	2,5 bar (36 psi) at 5 bar (73 psi) depending on the temperature
Relief valve adjustment pressure	5 bar (73 psi) (spring pressure)
Air suction type	Turbo air/air
Air preheating type	Grid Heater
Number of valves	4 per cylinder = 12
Inlet valve clearance value	0,35 mm (0.01 in) ± 0,05 mm (0.002 in)
Exhaust valve clearance value	0,35 mm (0.01 in) ± 0,05 mm (0.002 in)
Engine cooling system	Coolant
Fan type	Viscostatic
Thermostat begins to open at	83 °C (181 °F)
Liquid temperature from - to +	-35 °C (-31 °F) to 106 °C (223 °F)
Block preheater	110 or 220 volts
Fuel preheater	Not available

Rear axle transmission	
Gearbox type	GBA50
Transmission type	Dyna-4
Number of gears	16 gears

Rear axle transmission	
Maximum speed	40 km/h (25 mile/h)
Number of super creeper gears	32
Rear axle type	GPA52
Final drive type	GPA52
Main brake type	Multidisc ball ramp
Parking brake type	Hand brake on main brakes
Trailer brake type	Hydraulics
Hydraulic trailer braking pressure	0 to 150 bar (2176 psi)
Maximum operating tilt - pitch (front/rear)	25°
Maximum operating tilt - roll (right/left)	22°
Maximum operating tilt - combined	22°
Transmission preheater	Accessory kit available

Four-wheel drive front axle	
Front axle brand	DANA
Axle type	Fixed
Supplier reference - fixed front axle	725/154
Supplier reference - suspended front axle	-
Rotational direction	Anti-clockwise
Recommended oil type (beam and final drive)	SAE85W90 (API GL4-MIL L-2105)
Total ratio for front axle	12.462
Oscillation angle	± 9°
Type of oscillation stop	Mechanical
Steering ram diameter	36 mm (1.4 in) x 65 mm (2.6 in)
Steering ram stroke	2 x 105 mm (4.1 in)
Factor K	1.382

Two-wheel drive front axle	
Front axle brand	LODI 140 CP

Electrohydraulic	
System type	Open centre
Flow rate	57 l/min (15.1 gal/min (US)) or 100 l/min (26.4 gal/min (US))
High-pressure pump type	Gear pump(s)
Maximum pump pressure	200 bar (2901 psi)
Maximum quantity of oil to add for heavy implements	25 l (6.6 gal (US))
Maximum exportable oil quantity (without adding oil)	16 l (4.2 gal (US)) with a droop of 10%
Maximum exportable oil quantity (adding oil)	41 l (10.8 gal (US)) with a droop of 10%
Number of spool valves (maximum)	4
Spool valve control type	Mechanical
Recommended oil:	According to MF CMS M1145 specification

Steering	
Steering type	Hydrostatic
Type of control	Steering wheel
2-wheel drive Orbitrol displacement	80 cm <sup>3</sup> (4.88 in <sup>3</sup> )
4-wheel drive Orbitrol displacement	125 cm <sup>3</sup> (7.63 in <sup>3</sup> )
Steering ram diameter	36 mm (1.4 in) x 65 mm (2.6 in)
Steering ram stroke	2 x 105 mm (4.1 in)
Working pressure	175 bar (2538 psi) ± 5 bar (73 psi)
Pressure relief valve adjustment pressure	175 bar (2538 psi) ± 5 bar (73 psi)
Shock valve adjustment pressure	225 bar (3263 psi) to 245 bar (3553 psi)
Oil recommended for steering	According to MF CMS M1145 specification

Rear linkage	
Lift ram diameter	75 mm (3.0 in)
Maximum lifting capacity at ball joints	3330 kg (7341 lb)
Working pressure	180 bar (2611 psi)
3-point linkage category	2

Front linkage	
Lift ram diameter	80 mm (3.2 in) / 40 mm (1.6 in)
Maximum lifting capacity at ball joints	2236 kg (4929 lb)
Working pressure	190 bar (2756 psi)
3-point linkage category	2

Rear power take-off (PTO)	
Number of selections possible for rear PTO	540 540/540ECO 540/540ECO/1000
Rotational direction	Clockwise
Clutch type	Multidisc hydraulic
Control pressure	21 bar (305 psi)
Splined shaft type	6 or 21 x 1 <sup>3</sup> / <sub>8</sub> (diameter 35 mm (1.4 in)) splines or 20 x 1 <sup>3</sup> / <sub>4</sub> (diameter 45 mm (1.8 in)) splines

Front power take-off	
Number of selections possible for front PTO	1000 rpm
Rotational direction	Anti-clockwise
Clutch type	Multidisc hydraulic
Splined shaft type	6 or 21 x 1 <sup>3</sup> / <sub>8</sub> (diameter 35 mm (1.4 in)) splines

Electric	
Battery brand	TAB
Battery specifications	12 V - 105 A/H
Starter type	12 Volts
Alternator type	14 V/120 A

Electronics	
Function of each controller	
Autotronic 5	Transmission
Autotronic 5	Cab
Autotronic 5	Linkage

Cab and fittings	
Type of cab suspension available	Fixed low Fixed high Mechanical suspended high
Type of rear-view mirror control available	Manual
Type of air conditioning control available	Manual
Type and brand of air conditioning compressor	SANDEN with axial pistons
Compressor displacement	154.9 cm <sup>3</sup> /rev
Refrigerant	R134a
Cab noise level	71 DBA
Roof type	Standard High-visibility Slimline

### 3 Model MF 5610

Engine	
Brand	AGCO Power
Type	33 AWI
Maximum power hp (kW) (ISO TR14396) at 2000 rpm	106.08 (78.0)
Maximum torque (ISO TR14396)	413 Nm (305 lbf ft)
Maximum PTO power hp (kW) (OECD) at PTO 1000 rpm	-
Idle speed	710/850 rpm
Maximum speed	2260 rpm
Engine weight	350 kg (772 lb)
Number of cylinders	3
Engine cubic capacity	3,3 l (0.9 gal (US))
Piston travel	120 mm (4.7 in)
Piston diameter	108 mm (4.3 in)
Compression ratio	17.4:1
Compression pressure	-
Injection pump brand	Bosch
Injection pump type	Common rail CP4.1
Firing order	1-2-3
Fuel prefilter filtration capacity	10 $\mu$
Main fuel filter filtration capacity	5 $\mu$
Recommended oil:	CJ-4 or ACEA-E9
Lubrication system	By gear pump
Oil cooling system	Oil/water heat exchanger
Oil pressure at minimum speed	1 bar (15 psi)
Oil pressure at maximum speed	2,5 bar (36 psi) at 5 bar (73 psi) depending on the temperature
Relief valve adjustment pressure	5 bar (73 psi) (spring pressure)
Air suction type	Turbo air/air
Air preheating type	Grid Heater
Number of valves	4 per cylinder = 12
Inlet valve clearance value	0,35 mm (0.01 in) $\pm$ 0,05 mm (0.002 in)
Exhaust valve clearance value	0,35 mm (0.01 in) $\pm$ 0,05 mm (0.002 in)
Engine cooling system	Coolant
Fan type	Viscostatic
Thermostat begins to open at	83 °C (181 °F)
Liquid temperature from - to +	-35 °C (-31 °F) to 106 °C (223 °F)
Block preheater	110 or 220 volts
Fuel preheater	Not available

Rear axle transmission	
Gearbox type	GBA50
Transmission type	Dyna-4
Number of gears	16 gears



Rear axle transmission	
Maximum speed	40 km/h (25 mile/h)
Number of super creeper gears	32
Rear axle type	GPA54
Final drive type	GPA54
Main brake type	Multidisc ball ramp
Parking brake type	Hand brake on main brakes
Trailer brake type	Hydraulics
Hydraulic trailer braking pressure	0 to 150 bar (2176 psi)
Maximum operating tilt - pitch (front/rear)	25°
Maximum operating tilt - roll (right/left)	22°
Maximum operating tilt - combined	22°
Transmission preheater	Accessory kit available

Four-wheel drive front axle	
Front axle brand	DANA
Axle type	Fixed
Supplier reference - fixed front axle	725/155
Supplier reference - suspended front axle	-
Rotational direction	Anti-clockwise
Recommended oil type (beam and final drive)	SAE85W90 (API GL4-MIL L-2105)
Total ratio for front axle	14.571
Oscillation angle	± 9°
Type of oscillation stop	Mechanical
Steering ram diameter	36 mm (1.4 in) x 65 mm (2.6 in)
Steering ram stroke	2 x 105 mm (4.1 in)
Factor K	1.344

Two-wheel drive front axle	
Front axle brand	LODI 140 CP

Electrohydraulic	
System type	Open centre
Flow rate	57 l/min (15.1 gal/min (US)) or 100 l/min (26.4 gal/min (US))
High-pressure pump type	Gear pump(s)
Maximum pump pressure	200 bar (2901 psi)
Maximum quantity of oil to add for heavy implements	25 l (6.6 gal (US))
Maximum exportable oil quantity (without adding oil)	16 l (4.2 gal (US)) with a droop of 10%
Maximum exportable oil quantity (adding oil)	41 l (10.8 gal (US)) with a droop of 10%
Number of spool valves (maximum)	4
Spool valve control type	Mechanical
Recommended oil:	According to MF CMS M1145 specification

Steering	
Steering type	Hydrostatic
Type of control	Steering wheel
2-wheel drive Orbitrol displacement	80 cm <sup>3</sup> (4.88 in <sup>3</sup> )
4-wheel drive Orbitrol displacement	125 cm <sup>3</sup> (7.63 in <sup>3</sup> )
Steering ram diameter	36 mm (1.4 in) x 65 mm (2.6 in)
Steering ram stroke	2 x 105 mm (4.1 in)
Working pressure	175 bar (2538 psi) ± 5 bar (73 psi)
Pressure relief valve adjustment pressure	175 bar (2538 psi) ± 5 bar (73 psi)
Shock valve adjustment pressure	225 bar (3263 psi) to 245 bar (3553 psi)
Oil recommended for steering	According to MF CMS M1145 specification

Rear linkage	
Lift ram diameter	75 mm (3.0 in)
Maximum lifting capacity at ball joints	3330 kg (7341 lb)
Working pressure	180 bar (2611 psi)
3-point linkage category	2

Front linkage	
Lift ram diameter	80 mm (3.2 in) / 40 mm (1.6 in)
Maximum lifting capacity at ball joints	2236 kg (4929 lb)
Working pressure	190 bar (2756 psi)
3-point linkage category	2

Rear power take-off (PTO)	
Number of selections possible for rear PTO	540 540/540ECO 540/540ECO/1000
Rotational direction	Clockwise
Clutch type	Multidisc hydraulic
Control pressure	21 bar (305 psi)
Splined shaft type	6 or 21 x 1"3/8 (diameter 35 mm (1.4 in)) splines or 20 x 1"3/4 (diameter 45 mm (1.8 in)) splines

Front power take-off	
Number of selections possible for front PTO	1000 rpm
Rotational direction	Anti-clockwise
Clutch type	Multidisc hydraulic
Splined shaft type	6 or 21 x 1"3/8 (diameter 35 mm (1.4 in)) splines

Electric	
Battery brand	TAB
Battery specifications	12 V - 105 A/H
Starter type	12 Volts
Alternator type	14 V/120 A

Electronics	
Function of each controller	
Autotronic 5	Transmission
Autotronic 5	Cab
Autotronic 5	Linkage

Cab and fittings	
Type of cab suspension available	Fixed low Fixed high Mechanical suspended high
Type of rear-view mirror control available	Manual
Type of air conditioning control available	Manual
Type and brand of air conditioning compressor	SANDEN with axial pistons
Compressor displacement	154.9 cm <sup>3</sup> /rev
Refrigerant	R134a
Cab noise level	71 DBA
Roof type	Standard High-visibility Slimline

Thank you so much for reading.  
Please click the “Buy Now!”  
button below to download the  
complete manual.



After you pay.

You can download the most  
perfect and complete manual in  
the world immediately.

Our support email:

[ebooklibonline@outlook.com](mailto:ebooklibonline@outlook.com)