

3309
Mower Conditioner

Service Manual

8-96760

Reprinted

CASE III

3309 Mower Conditioner Service Manual

Table of Contents

Description	Section No.	Form No.
General	Tab 1	
Safety Rules, Servicing, Transporting	1001	8-96760
Torque Specifications	1001	8-96760
General Machine Specifications	1001	8-96760
Maintenance and Lubrication	1001	8-96760
Electrical	Tab 4	
Checking Light Electrical Circuit	4001	8-96760
Hydraulics	Tab 8	
Tongue Positioning Hydraulic Cylinder	8001	8-96760
Header Lift Hydraulic Cylinder	8001	8-96760
Conditioning Roll Hydraulic Cylinder	8001	8-96760
Chassis	Tab 9	
Frame and Header Float Wheel and Hub	9001	8-96760
PTO Shaft	9002	8-96760
Gear Case	9003	8-96760
Cutterbar	9004	8-96760
Disc Drive Unit	9005	8-96760
Lower Conditioning Roll	9006	8-96760
Upper Conditioning Roll	9007	8-96760

Section

1001

SAFETY
GENERAL INFORMATION
MACHINE SPECIFICATIONS
TORQUE SPECIFICATIONS
MAINTENANCE AND LUBRICATION

TABLE OF CONTENTS

Safety Rules, Servicing, Transporting	3
Safety Warning Decals	4
General Service Manual Introduction, General Servicing Information	10
Torque Specifications, General Machine Specifications	11
Maintenance and Lubrication	14

SAFETY RULES



THIS SAFETY ALERT SYMBOL INDICATES IMPORTANT SAFETY MESSAGES IN THIS MANUAL. WHEN YOU SEE THIS SYMBOL, CAREFULLY READ THE MESSAGE THAT FOLLOWS AND BE ALERT TO THE POSSIBILITY OF PERSONAL INJURY OR DEATH. M171A

SAFETY IS A MUST!

Develop and follow good safety practices for yourself and those around you.

Always operate farm machinery in a careful, safe manner.

Never attempt to clean, adjust or lubricate a machine while it is running.

Always shut off P.T.O. and engine before leaving tractor seat. Remember "Safety is no accident."

SERVICING

READ THIS MANUAL THOROUGHLY BEFORE SERVICING THE EQUIPMENT.

Do not wear loose fitting clothing. It may catch in moving parts.

Install the mower on a tractor with an operator enclosure.

See that all safety shields, including the shield for the tractor power take-off parts, are installed and properly secured.

Do not stand on the curtain guard.

Make sure that there is no one near the machine before starting it.

Be sure the tractor power take-off is disengaged before starting the tractor engine.

TRANSPORTING

Always place the machine in the transport position, and install header safety straps.

Make sure the tractor or truck pulling the disc mower conditioner is in safe operating condition with adequate braking capabilities.

Avoid heavily traveled roads and drive at a safe speed, not more than 20 m.p.h. (32 km/h) to maintain complete control of the machine at all times.

Use warning devices (i.e. flags, S.M.V. emblem, lamps, etc.) which are approved for use by your local government agencies, when moving equipment on public roads. Keep these devices clean and in good working condition.

Your machine is equipped with two red reflectors located on the rear of the machine, on the right and left sides (an S.M.V. sign is also provided). These reflectors and the S.M.V. sign must be kept clean.

When transporting on the highway, it is recommended that a safety chain package with a 10,500 pounds (4767 kg.) gross load capacity be used with the towing vehicle and the implement. The gross weight of the trailed equipment without brakes, should not exceed the weight of the towing vehicle.

Comply with your state and local laws and with regulations governing highway safety, when moving machinery on a highway.



Develop and practice safe operating procedures for yourself and insist that your family, employees and visitors to your farm do the same. Be careful! Safety is your concern.

SAFETY WARNING DECALS

The following warning decals are installed to alert operators to dangers in specific machine areas. The decals are for personal safety; **OBSERVE THEM!**

Keep decals clean. Wipe off regularly or use cleaning solution.

Replace decals if missing, damaged or painted over.

Clean machine surface thoroughly with cleaning solution when replacing decals.

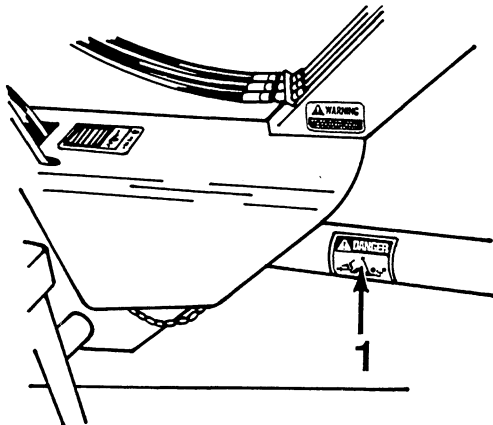
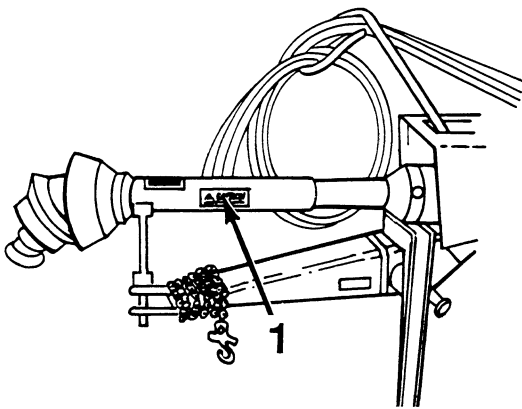

"1"
P/N 96335C1
BLACK & YELLOW

SAFETY WARNING DECALS

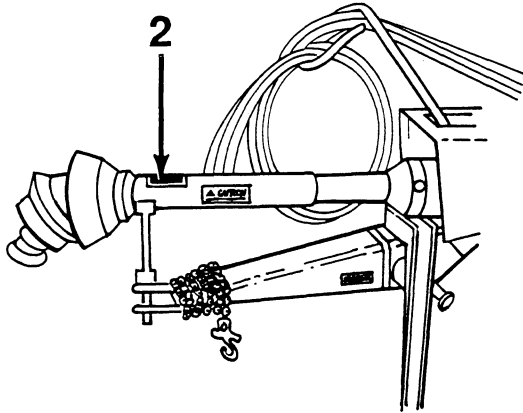

"2"
P/N 96319C1
RED & WHITE

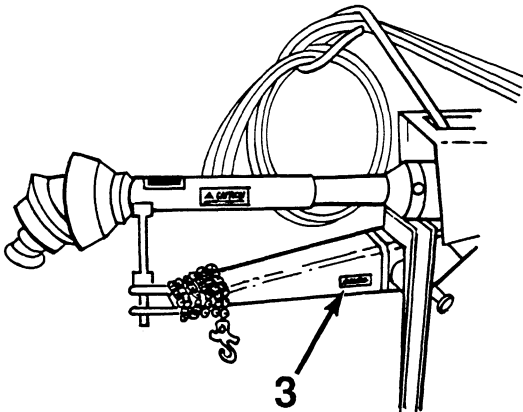

"3"
P/N 1326528C1
BLACK & YELLOW

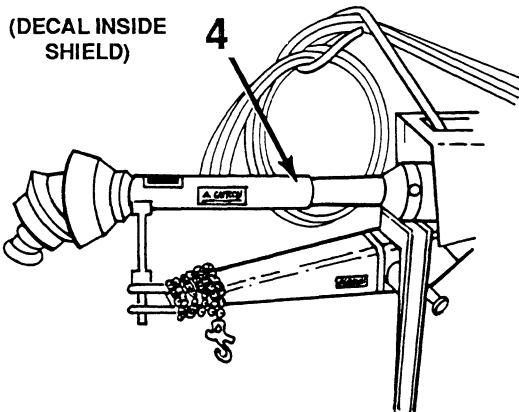

"4"
P/N 96332C1
BLACK & YELLOW

SAFETY WARNING DECALS

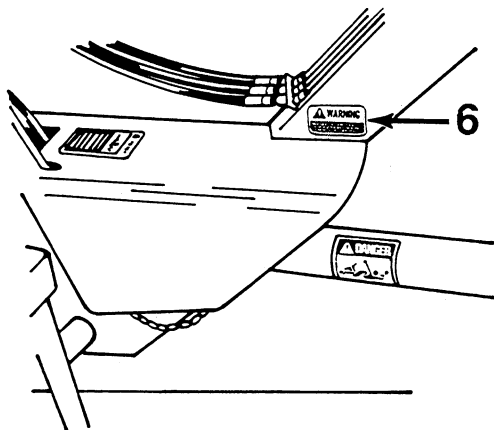
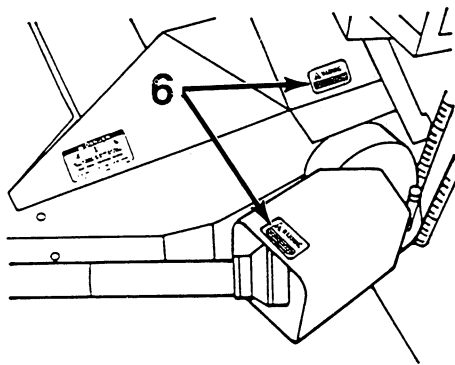
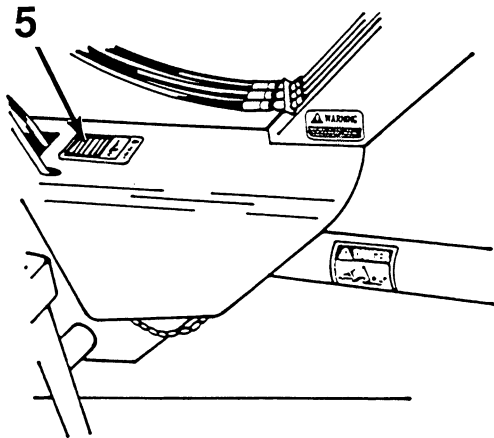

"5"
P/N 56156C2
RED & WHITE



"6"
P/N ZA740950
BLACK & YELLOW

SAFETY WARNING DECALS

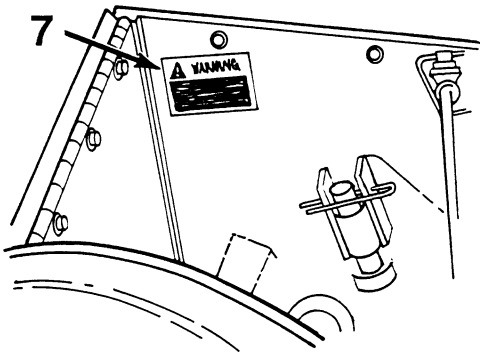
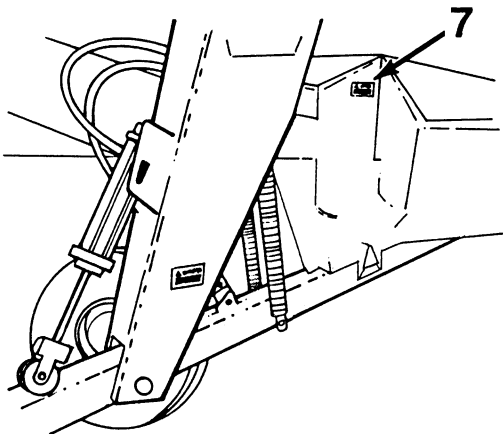
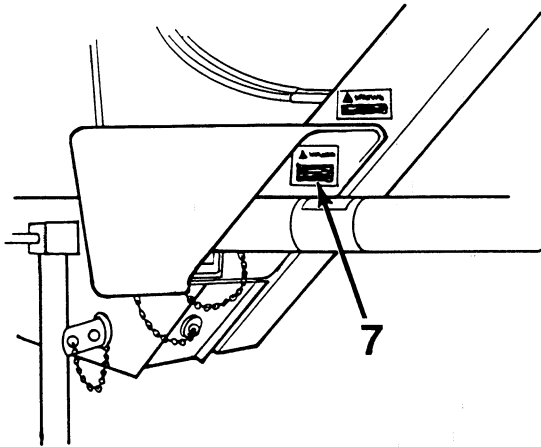

Shields are provided to guard these moving parts.

AVOID INJURY—
Keep them in place.

"7"

P/N 96327C1
BLACK & YELLOW

SAFETY WARNING DECALS

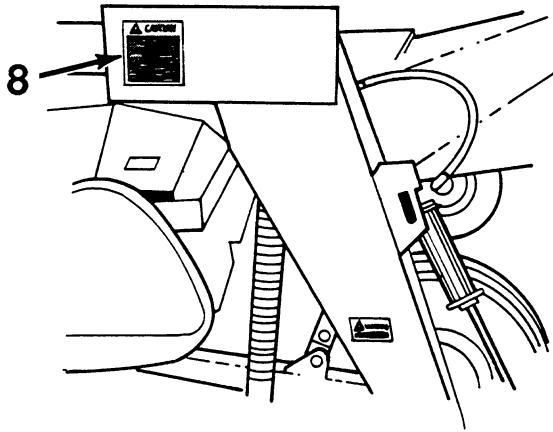

CAUTION

- 1 Read and understand the Operator's Manual
- 2 Stop the tractor engine before leaving the operator's platform
- 3 Keep riders off the machine
- 4 Make certain everyone is clear of the machine before starting the tractor engine and operating
- 5 Keep all shields in place
- 6 Never lubricate, adjust, unplug or service the machine with tractor engine running
- 7 Wait for all movement to stop before servicing
- 8 Keep hands, feet and clothing away from moving parts
- 9 Use flashing warning lights when operating on highways except when prohibited by law

"8"

P/N ZA527080
BLACK & YELLOW

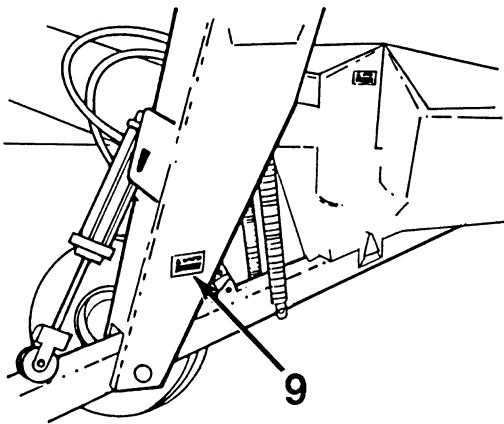

WARNING

TO AVOID INJURY . .

Insert pin through safety strap to lock header in up position whenever working under header.

"9"

P/N ZA527078

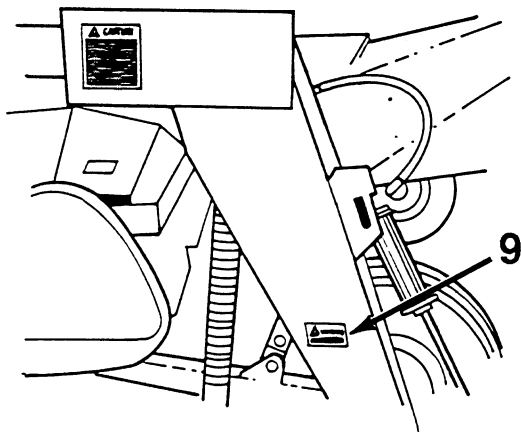

SAFETY WARNING DECALS

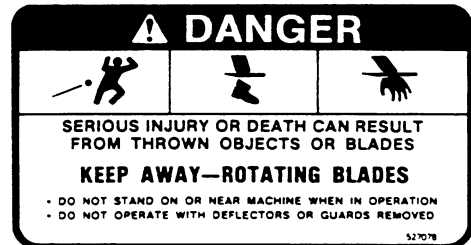
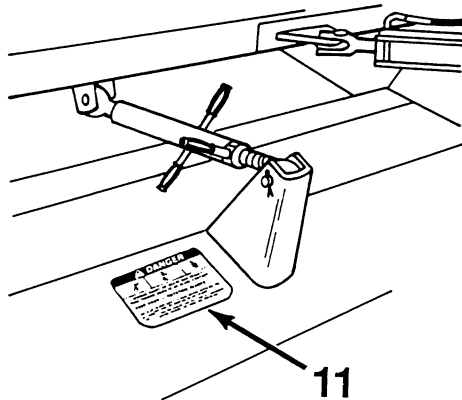
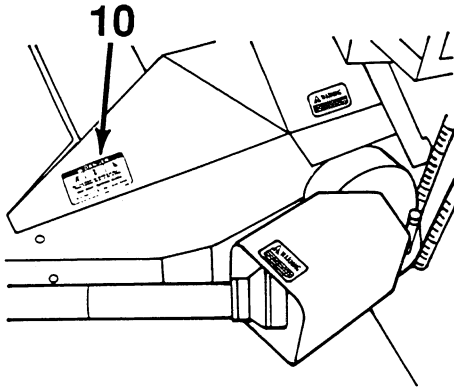
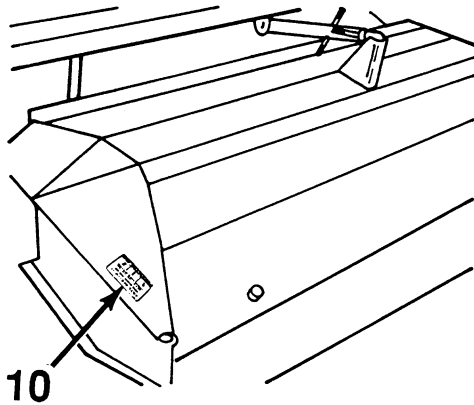

“10”
P/N ZA527079

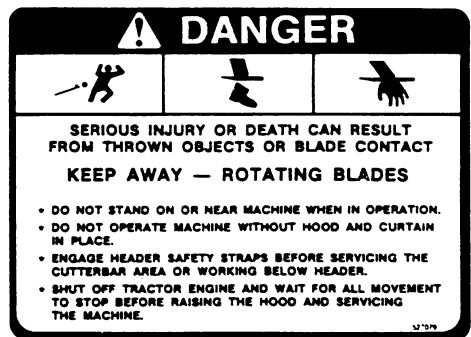

“11”
P/N ZA527079

GENERAL SERVICE MANUAL INTRODUCTION

Know the Equipment

Study this Service Manual carefully. It has been specially designed to provide concise procedures for properly servicing the equipment. Always check the manual first.

Right and Left-Hand Side of Machine

Stand behind the machine and face the direction of travel to determine right and left-hand machine sides.

Serial Numbers

The serial number is located on the left side of the main frame.

ATTENTION! PICTURES IN THIS MANUAL MAY SHOW PROTECTIVE SHIELDS AND GUARDS OPENED OR REMOVED FOR ILLUSTRATION PURPOSES. BE CERTAIN ALL SHIELDS AND GUARDS ARE IN PLACE DURING OPERATION.

GENERAL SERVICING INFORMATION

CLEANING - Before any service work is done, clean the complete outside surface. Clean all internal metal parts in cleaning solvent or by steam cleaning. Do not use caustic soda for steam cleaning. After cleaning, dry and lubricate all parts. Clean oil passages with compressed air.

INSPECTION - Visually inspect all parts when disassembled. Replace all parts that have wear or damage. The replacement of parts as necessary will prevent early failure.

GEARS - Check all gears for wear and damage. Replace worn or damaged gears.

OIL SEALS, O-RINGS AND GASKETS - Always install new oil seals, O-rings and gaskets. Put oil or petroleum jelly on seals and O-rings.

BEARINGS - Check bearings for smooth action. If a bearing has a loose fit or rough action, replace the bearing. If necessary, wash bearings with clean solvent and permit to air dry. **DO NOT DRY WITH COMPRESSED AIR.** Lubricate bearings after cleaning to prevent rust.



Bearings can be heated in a bearing oven for assembly. Do not use a torch to heat bearings. Do not heat the bearing beyond a temperature of 300°F (150°C). Heating will temporarily increase the clearance between the shaft and inner bearing race so that a hydraulic press is not needed when installing a bearing on a shaft.









Use only metric tools on metric fasteners.

After servicing, be sure all tools, parts, and servicing equipment are removed from the machine.

TORQUE SPECIFICATIONS

METRIC FASTENER (ISO) TORQUE CHART												
NOTE: Use these torques, unless special torques are specified. Values are for coarse thread fasteners, plated or unplated, as received from supplier. Fasteners can be dry or lubricated with normal engine oil. Values do not apply if graphite, moly-disulphide or other extreme pressure lubricant is used.												
ISO Class No.	8.8				10.9				12.9			
Bolt head identification (See Note 1)												
Bolt Size	Nm		LB FT		Nm		LB FT		Nm		LB FT	
	Min.	Max.	Min.	Max.	Min.	Max.	Min.	Max.	Min.	Max.	Min.	Max.
M4	3	4	2	3	4	5	3	4	Because of the low ductility of these fasteners, the torque range is to be determined individually for each application. As a general rule, the torque ranges specified for grade 10.9 fasteners can be used satisfactorily on 12.9 fasteners. *M14 is not a preferred size.			
M5	6.5	8	5	6	9.5	11	7	8				
M6	10.5	12	8	9	15	17.5	11	13				
M8	26	31	19	23	37	43	27	32				
M10	52	61	38	45	73	87	54	64				
M12	90	107	66	79	125	150	93	112				
*M14	144	172	106	127	200	245	149	179				
M16	217	271	160	200	310	380	230	280				
M20	434	515	320	380	610	730	450	540				
M24	675	815	500	600	1050	1275	780	940				
M30	1250	1500	920	1100	2000	2400	1470	1770				
M36	2175	2600	1600	1950	3500	4200	2580	3090				

NOTE 1: Bolt head identification marks as per grade. Manufacturing marks will vary.

SAE FASTENERS TORQUE CHART												
NOTE: Use these torques, unless special torques are specified. Values are for UNC and UNF fasteners, plated or unplated, as received from supplier. Fasteners can be dry or lubricated with normal engine oil. Values do not apply if graphite, moly-disulphide or other extreme pressure lubricant is used.												
SAE Grade No.	2				5				8*			
Bolt head identification (See Note 1)					  				  			
Bolt Size	LB FT		Nm		LB FT		Nm		LB FT		Nm	
	Min.	Max.	Min.	Max.	Min.	Max.	Min.	Max.	Min.	Max.	Min.	Max.
1/4	5	6	7	8	9	11	12	15	12	15	16	20
5/16	10	12	14	16	17	20.5	23	28	24	29	33	39
3/8	20	23	27	31	35	42	48	57	45	54	61	73
7/16	30	35	41	47	54	64	73	87	70	84	95	114
1/2	45	52	61	70	80	96	109	130	110	132	149	179
9/16	65	75	88	102	110	132	149	179	160	192	217	260
5/8	95	105	129	142	150	180	203	244	220	264	298	358
3/4	150	185	203	251	270	324	366	439	380	456	515	618
7/8	160	200	217	271	400	480	542	651	600	720	814	976
1	250	300	339	406	580	696	787	944	900	1080	1220	1464
1-1/8					800	880	1085	1193	1280	1440	1736	1953
1-1/4					1120	1240	1519	1681	1820	2000	2468	2712
1-3/8					1460	1680	1980	2278	2380	2720	3227	3688
1-1/2					1940	2200	2631	2983	3160	3560	4285	4827

NOTE 1: Bolt head identification marks as per grade. Manufacturing marks will vary. *Thick nuts must be used with Grade 8 bolts.

Thank you so much for reading.
Please click the “Buy Now!”
button below to download the
complete manual.



After you pay.

You can download the most
perfect and complete manual in
the world immediately.

Our support email:

ebooklibonline@outlook.com