

**JX60
JX70
JX80
JX90
JX95
Tractors**

Service Manual

Print No. 84176554B

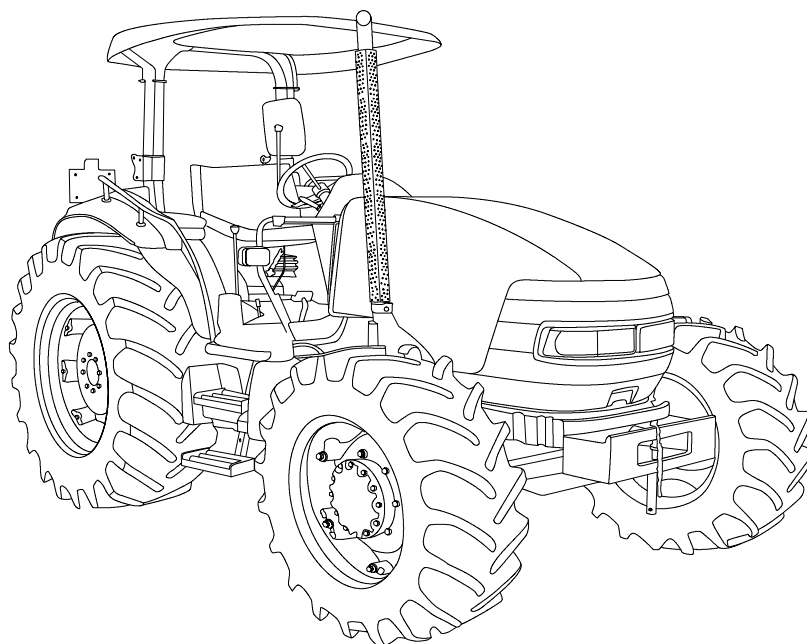



JX60 - JX70 - JX80 - JX90 - JX95 MODEL TRACTORS SERVICE MANUAL

SECTIONS	
GENERAL	00
ENGINE	10
CLUTCH	18
GEARBOX	21
TRANSMISSION OF MOTION	23
FRONT MECHANICAL TRANSMISSION	25
REAR MECHANICAL TRANSMISSION	27
POWER TAKE-OFF	31
BRAKES	33
HYDRAULIC SYSTEMS	35
STEERING	41
AXLE AND WHEELS	44
AUXILIARY EQUIPMENT	50
ELECTRICAL SYSTEM	55
CAB	90

S E R V I C E

Repair Manual - JX Series Tractors

CONTENTS

GENERAL

SECTION 00

General Instructions and Health and Safety

Chapter 1

Section	Description	Page
00 000	General instructions	1
	Notes for spare parts	2
	Notes for equipment	2
	Safety rules	3
	Consumables	6

ENGINE

SECTION 10

Engine System (F5C)

Chapter 1

Section	Description	Page
	Tools	2
	Engine Troubleshooting	3
10 001 10	Engine R.I.	7

Engine System(NEF)

Chapter 1

Section	Description	Page
	General specifications	2
	Data	5
	Tightening torques	11
	Tools	2
	Engine views	14
	Lubrication diagram	15
	Cooling system diagram	16
	Fault diagnosis	3
10 001 10	Engine R.I.	7
10 001 53	Engine D.A. Checks, measurements and repairs	37
10 102 70	Crankshaft front seal - Replacement	89
10 102 74	Crankshaft rear seal - Replacement	92
10 106 12	Valve tappet and rocker arm clearance - Adjustment	95
10 218 30	Engine injector R.I.	98
10 246 14	Bosch injection pump R.I. Timing. Air bleed	100
10 402 10	Coolant pump R.I.	108
10 402 30	Thermostat valve R.I.	110
10 406 10	Radiator R.I.	112

10 414 10	Coolant pump and generator drive belts. Tension adjustment	116
-----------	--	-----

CLUTCH

SECTION 18

Clutches

Chapter 1

Section	Description	Page
18 000	General specifications	1
	Tightening torques	4
	Tools	5
	Cross-sectional views	6
	Clutch Troubleshooting	8
18 110 10	Removal - Installation	9
	Overhaul	18
	Minimum permissible dimensions after refacing	22
	Adjustments	23
18 100 40	Adjustment of the main and PTO clutch control linkage	25

GEARBOX

SECTION 21

Mechanical Transmission (12x4)

Chapter 1

Section	Description	Page
21 000	Main data	1
	Tightening torques	2
	Tools	3
	Section views	3&5
	Description and operation	8
	Fault diagnosis	8
21 110	Removal - Refitting	see sect 27

Reverser (12x12)

Chapter 2

Section	Description	Page
21 000	Main data	1
	Tightening torques	2
	Tools	3
	Section views	3
	Description and operation	5
	Fault diagnosis	5
21 110	Removal-Refitting	6

Reverser and Creeper (20x12)

Chapter 3

Section	Description	Page
21 000	Main data	1
	Tightening torques	2
	Tools	3
	Section views	4
	Description and operation	6
	Fault diagnosis	6
21 110	Removal-Refitting	7

DRIVE LINES

SECTION 23

Drive Lines

Chapter 1

Section	Description	Page
23 000	Main specification	1
	Torque settings and Tools	2
	Cross-Sectional views	3
23 101 26	Transmission shafts and guard (Disassembly - Assembly)	4
23 101 40	Drive gear housing (Removal - Installation)	5
23 101 42	Drive gear housing removed (Disassembly - Assembly)	7

FRONT AXLE MECHANICAL TRANSMISSION

SECTION 25

Front Axle Mechanical Transmission

Chapter 1

Section	Description	Page
25 000	Main data	1
	Tightening torques	4
	Tools	6
	Cross-sectional views	7
	Description and operation	9
25 100 30	Complete front axle. Removal - Installation	10
25 100 38	Front axle. Removal - Installation	14
25 108 46-47	Steering knuckle bearing pins. Replacement	24
	Stub axle adjustment	25
	Wheel hub bearing adjustment	27
	Bevel drive adjustment	29
25 102 24	Front axle differential. Overhaul	36
25 100 27	Front axle differential with LIM-SLIP. Overhaul	37
	Front axle differential with NO SPIN. Overhaul	39
44 511 80	Leading drive wheels toe-in check	42

REAR AXLE AND TRANSMISSION

SECTION 27

Rear Axle And Transmission

Chapter 1

Section	Description	Page
27 000	Main data	1
	Tightening torques	3
	Special tools	5
	Cross-sectional views	7
	Description and operation and troubleshooting	9
21.118.10 - 12	Transmission-gearbox casing Removal-Installation	10
21.118.85	Transmission-gearbox casing Disassembly-Overhaul	34
	Gearbox driven shaft end float adjustment	42
	Differential lock engagement sleeve adjustment	43
	Determining the bevel pinion positioning adjustment ring	44
	Adjusting the taper roller bearings for the bevel pinion shaft	46
	Adjusting the bearings and checking the backlash	47

POWER TAKE-OFF

SECTION 31

Mechanical Power Take - Off

Chapter 1

Section	Description	Page
31 000	Main specification	1
	Tools	3
	Torque settings	4
	Sectional drawings	5
	Description and operation	10
	Troubleshooting	12
	Removal - Refitting	13
31 101	Bench overhaul	16

BRAKING SYSTEM

SECTION 33

Braking System

Chapter 1

Section	Description	Page
33 000	Main data	1
	Tightening torques	2
	Cross-sectional views	2
	Description & Operation	9
	Tools - Troubleshooting	10
33.206	Front brake assembly mod. JX60 and JX70 removal and refitting - overhauling on the bench	11
33.202.60	Service brake removal and refitting	14
33.202.50	Removal-Refitting of front brake pumps	19
33.202.40	Bleeding air from the front braking system	23
33.120.08	Adjusting service brake pedals travel	24
33.110.08	Parking brake travel adjustment	24

HYDRAULIC SYSTEM

SECTION 35

Rear Mechanical Hydraulic Lift

Chapter 1

Section	Description	Page
35 000	Main specification	1
	Tightening torques	3
	Tools	6
	Cross-sectional views	7
	Description & Operation	9
	Hydraulic circuit	9
	Description and operation of lift phases	10
35 110.30	Fault diagnosis	13
	Hydraulic lift - disassembly reassembly	15

35.110.40-42-46	Hydraulic lift – bench overhaul	21
	Adjusting the lift	26
35.110.08	Linkage adjustment	32
35.110.30	Pressure relief valve – disassembly reassembly	34
35.110.32	Pressure relief valve – setting	34
35.110.14	Lift control valve – disassembly assembly and overhaul on bench	36
35.0101.10	Lift pump	41

Open Centre System Auxiliary Control Valves

Chapter 2

Section	Description	Page
35 000	Main data – Tools	1
	Auxiliary control valves – sectional views	2
	Description and operation	3
	Fault diagnosis	see chapter 1
35 204 46	Auxiliary control valves – Assembly-Disassembly	7
	Spool binding test	15
	Spool leakage test	16
	Adjustment of the automatic detent release pressure	17

Trailer Brake Auxiliary Control Valve

Chapter 3

Section	Description	Page
35 000	Section views	1
	Description and operation	1
	Hydraulic diagram	2
	Description and operation of valve phases	3
	Trailer brake auxiliary control valve linkage adjustment	6

STEERING

SECTION 41

Steering

Chapter 1

Section	Description	Page
41 000	Principal data	1
	Tightening torques	3
	Section views	4
	Hydraulic diagram	6
	Operation	7
	Fault diagnosis	9
	Tools	6
41 204 30	Hydrostatic steering control valve – Removal-Installation	11
41 204 34	Hydrostatic steering control valve – Disassembly-Assembly	14
41 204 38	Hydrostatic steering control valve – Bench testing	28
	Hydrostatic steering oil pump – Disassembly-Assembly	30
41 216 20	Steering cylinder (two-wheel drive axle) – Removal-Refitting	32
	Steering cylinder (four wheel drive axle) – Removal-Refitting	33

FRONT AXLE AND WHEELS

SECTION 44

Front Axle And Wheels

Chapter 1

Section	Description	Page
44 000	Principal data	1

	Sectional views	3
	Torque settings	3
	Equipment - Fault diagnosis	5
44 101 30	Removal-Refitting-Overhaul	6
44 101 22	Wheel hub disassembly-assembly	9
44 101 46	Stub axle overhaul	16
44 101 80	Checking wheel alignment	20

AUXILIARY UNITS

SECTION 50

Auxiliary Units

Chapter 1

Section	Description	Page
50 000	Safety instructions	2
	General characteristics	3
	Equipment	4
	Operating principles	5
	Fault diagnosis	7
	Cab controls	11
	Use	14
	Main components of the cab air conditioning system	15
	Refrigerant recovery-recycling and evacuation-charging stations	20
50 200 04	Drying recharging and checking cooling	22
50 200 03	Functional testing of air conditioning system	27
	Summary of the cab air-conditioning system charging operations	28
	Checking for refrigerant leaks using an electronic leak detector	30
	Summary of fault diagnosis and maintenance	31
	Air conditioning and heating pipes - Replacement	33
50 200 04-74	Receiver-drier - Replacement	36
50 200 04-72	Condenser - Replacement	38
50 200 04-26	Compressor - Removal-Refitting	39
50 200 10	Compressor drive belt tension adjustment	41

ELECTRICAL SYSTEM

SECTION 55

Instruments

Chapter 1

Section	Description	Page
55 418	Analogue instruments and introduction	1
	Transmitter and switches	4

Components

Chapter 2

Section	Description	Page
---------	-------------	------

55 500	Introduction	1
	Component description	1

Starting System

Chapter 3

Section	Description	Page
55 000	Technical information	1
	Tightening torques	1
	Description and operation	2
	Starting circuit	3
	System tests	5
55 201	Removal and re-installation of starter motor	8
	Servicing	9
	Bench tests	10

Charging System

Chapter 4

Section	Description	Page
55 000	Technical information	1
	Tightening torques	1
	Description and operation	2
	System testing and trouble-shooting	4
55 301	Removal, re-installation and servicing	10

Battery

Chapter 5

Section	Description	Page
55 000	Technical information	1
	Description and operation	1
55.301.040	Removal and re-installation	2
	Battery checking and maintenance	3
	Charging the battery	4
	Battery problems - Frequent causes	7

Electrical Circuits

Chapter 6

Section	Description	Page
55 100	Contents	1
	Fuses (all versions)	2
	Symbols used in electrical circuits	4
	Electrical wire colour coding	5
	Ground locations	5
	Electrical diagrams	
	- General diagrams (W/Cab)	9
	- General diagrams (W/Out Cab)	15

- Analogue instrument circuit and connector overview 19
- Start-up circuit and connector overview 21
- Direction indicator & hazard warning light circuit and connector overview 25
- Windscreen and rear window wiper/washer circuit and connector overview ... 31
- Brake light circuit and connector overview 35
- Heating and air-conditioning system circuit and connector overview 41
- Work lamp (without cab circuit and connector overview) 45
- Work lamp (without cab circuit and connector overview) 49
- Side lights,main and dipped headlights, parking light circuit and connector
overview 53

BODYWORK AND DRIVER POSITION

SECTION 90

Bodywork And Driver Position

Chapter 1

Section	Description	Page
90 000	Disassembly-Assembly	1

GENERAL INSTRUCTIONS

IMPORTANT NOTICE

All maintenance and repair operations described in this manual should be carried out exclusively by the CASE IH authorised workshops. All instructions detailed should be carefully observed and special equipment indicated should be used if necessary.

Everyone who carries out service operations described without carefully observing these prescriptions will be directly responsible of deriving damages.

SHIMMING

At each adjustment, select adjusting shims, measure them individually using a micrometer and then sum up recorded values. Do not rely on measuring the whole shimming set, which may be incorrect, or on rated value indicated for each shim.

ROTATING SHAFT SEALS

To correctly install rotating shaft seals, observe the following instructions:

- Let the seal soak into the same oil as it will seal for at least half an hour before mounting;
- Thoroughly clean the shaft and ensure that the shaft working surface is not damaged;
- Place the sealing lip towards the fluid. In case of a hydrodynamic lip, consider the shaft rotation direction and orient grooves in order that they deviate the fluid towards the inner side of the seal;
- Coat the sealing lip with a thin layer of lubricant (oil rather than grease) and fill with grease the gap between the sealing lip and the dust lip of double lip seals;
- Insert the seal into its seat and press it down using a flat punch. Do not tap the seal with a hammer or a drift;
- Take care to insert the seal perpendicularly to its seat while you are pressing it. Once the seal is settled, ensure that it contacts the thrust element if required.;
- To prevent damaging the sealing lip against the shaft, place a suitable protection during installation.

O RINGS

Lubricate the O rings before inserting them into their seats. This will prevent the O rings from rolling over and twine during mounting which will jeopardise sealing.

SEALERS

Apply one of the following sealers: RTV SILMATE, RHODORSIL CAF 1, or LOCTITE PLASTIC GASKET over the mating surfaces marked with an X.

Before applying the sealer, prepare the surface as follows:

- remove possible scales using a metal brush;
- thoroughly degrease the surfaces using one of the following cleaning agent: trichlorethylene, petrol or a water and soda solution.

BEARINGS

It is advisable to heat the bearings to 80 to 90°C before mounting them on their shafts and cool them down before inserting them into their seats with external tapping.

ROLL PINS

When fitting straight roll pins, ensure that the pin notch is oriented in the direction of the effort to stress the pin. Coil roll pins can be installed in any position.

NOTES FOR SPARE PARTS

Use exclusively **genuine CASE IH spare parts**.

Only genuine parts guarantee same quality, life, safety as original components as they are the same as mounted in production.

Only the **CASE IH genuine spare parts** can offer this guarantee.

All spare parts orders should be complete with the following data:

- tractor model (commercial name) and frame number;
- engine type and number;
- part number of the ordered part, which can be found on the "Microfiches" or the "Spare Parts Catalogue", which is the base for order processing.

NOTES FOR EQUIPMENT

Equipment which CASE IH proposes and shows in this manual are as follows:

- studied and designed expressly for use on CASE IH tractors;
- necessary to make a reliable repair;
- accurately built and strictly tested to offer efficient and long-lasting working means.

We also remind the Repair Personnel that having these equipment means:

- work in optimal technical conditions;
- obtain best results;
- save time and effort;
- work more safely.

NOTICES

Wear limits indicated for some details should be intended as advised, but not binding values. The words "front", "rear", "right hand", and "left hand" referred to the different parts should be intended as seen from the operator's seat oriented to the normal sense of movement of the tractor.

HOW TO MOVE THE TRACTOR WITH THE BATTERY REMOVED

Cables from the external power supply should be connected exclusively to the respective terminals of the tractor positive and negative cables using pliers in good condition which allow proper and steady contact.

Disconnect all services (lights, wind-shield wipers, etc.) before starting the tractor.

If it is necessary to check the tractor electrical system, check it only with the power supply connected. At check end, disconnect all services and switch the power supply off before disconnecting the cables.

SAFETY RULES

PAY ATTENTION TO THIS SYMBOL



This warning symbol points out important messages involving personal safety. Carefully read the safety rules contained herein and follow advised precautions to avoid potential hazards and safeguard your safety and personal integrity.

In this manual you will find this symbol together with the following key-words:

WARNING - it gives warning about improper repair operations and deriving potential consequences affecting the service technician's personal safety.

DANGER - it gives specific warning about potential dangers for personal safety of the operator or other persons directly or indirectly involved.



TO PREVENT ACCIDENTS

Most accidents and personal injuries taking place in workshops are due from non-observance of some simple and essential prudential rule and safety precautions. For this reason, **IN MOST CASES THEY CAN BE AVOIDED.** It suffices to foresee possible causes and act consequently with necessary caution and care.

The possibility that an accident might occur with any type of machines should not be disregarded, no matter how well the machine in question was designed and built.

A wise and careful service technician is the best precautions against accidents.

Careful observance of this only basic precaution would be enough to avoid many severe accidents.

DANGER: Never carry out any cleaning, lubrication or maintenance operations when the engine is running.

SAFETY RULES

GENERALITIES

- ◇ Carefully follow specified repair and maintenance procedures.
- ◇ Do not wear rings, wristwatches, jewels, unbuttoned or flapping clothing such as ties, torn clothes, scarves, open jackets or shirts with open zips which could get hold into moving parts. We advise to use approved safety clothing such as anti-slipping footwear, gloves, safety goggles, helmets, etc.
- ◇ Never carry out any repair on the machine if someone is sitting on the operator's seat, except

if they are certified operators to assist in the operation to be carried out.

- ◇ Never operate the machine or use attachments from a place other than sitting at the operator's seat.
- ◇ Never carry out any operation on the machine when the engine is running, except when specifically indicated.
- ◇ Stop the engine and ensure that all pressure is relieved from hydraulic circuits before removing caps, covers, valves, etc.
- ◇ All repair and maintenance operations should be carried out with the greatest care and attention.
- ◇ Service stairs and platforms used in a workshop or in the field should be built in compliance with the safety rules in force.
- ◇ Disconnect the batteries and label all controls to warn that the tractor is being serviced. Block the machine and all equipment which should be raised.
- ◇ Never check or fill fuel tanks and accumulator batteries, nor use starting liquid if you are smoking or near open flames as such fluids are flammable.
- ◇ Brakes are inoperative when they are manually released for maintenance purposes. In such cases, the machine should be kept constantly under control using blocks or similar devices.
- ◇ The fuel filling gun should remain always in contact with the filler neck. Maintain this contact until the fuel stops flowing into the tank to avoid possible sparks due to static electricity buildup.

- ◇ Use exclusively specified towing points for towing the tractor. Connect parts carefully. Ensure that foreseen pins and/or locks are steadily fixed before applying traction. Do not stop near towing bars, cables or chains working under load.
- ◇ To transfer a failed tractor, use a trailer or a low loading platform trolley if available.
- ◇ To load and unload the machine from the transportation mean, select a flat area providing a firm support to the trailer or truck wheels. Firmly tie the machine to the truck or trailer platform and block wheels as required by the forwarder.
- ◇ For electrical heaters, battery-chargers and similar equipment use exclusive auxiliary power supplies with a efficient ground to avoid electrical shock hazard.
- ◇ Always use lifting equipment and similar of appropriate capacity to lift or move heavy components.
- ◇ Pay special attention to bystanders.
- ◇ Never pour gasoline or diesel oil into open, wide and low containers.
- ◇ Never use gasoline, diesel oil or other flammable liquids as cleaning agents. Use non-flammable non-toxic proprietary solvents.
- ◇ Wear protection goggles with side guards when cleaning parts using compressed air.
- ◇ Do not exceed a pressure of 2.1 bar, in accordance with local regulations.
- ◇ Do not run the engine in a closed building without proper ventilation.
- ◇ Do not smoke, use open flames, cause sparks in the nearby area when filling fuel or handling highly flammable liquids.
- ◇ Do not use flames as light sources when working on a machine or checking for leaks.
- ◇ Move with caution when working under a tractor, and also on or near a tractor. Wear proper safety accessories: helmets, goggles and special footwear.
- ◇ During checks which should be carried out with the engine running, ask an assistant to seat at the operator's seat and keep the service technician under visual control at any moment.
- ◇ In case of operations outside the workshop, drive the tractor to a flat area and block it. If working on an incline cannot be avoided, first block the tractor carefully. Move it to a flat area as soon as possible with a certain extent of safety.
- ◇ Ruined or plied cables and chains are unreliable. Do not use them for lifting or trailing. Always handle them wearing gloves of proper thickness.
- ◇ Chains should always be safely fastened. Ensure that fastening device is strong enough to hold the load foreseen. No persons should stop near the fastening point, trailing chains or cables.
- ◇ The working area should be always kept CLEAN and DRY. Immediately clean any spillage of water or oil.
- ◇ Do not pile up grease or oil soaked rags, as they constitute a great fire hazard. Always place them into a metal container.
Before starting the tractor or its attachments, check, adjust and block the operator's seat. Also ensure that there are no persons within the tractor or attachment operating range.
- ◇ Do not keep into your pockets any object which might fall unobserved into the tractor's inner compartments.
- ◇ Whenever there is the possibility of being reached by ejected metal parts or similar, use protection eye mask or goggles with side guards, helmets, special footwear and heavy gloves.
- ◇ Wear suitable protection such as tinted eye protection, helmets, special clothing, gloves and footwear whenever it is necessary to carry out welding procedures. All persons standing in the vicinity of the welding process should wear tinted eye protection. NEVER LOOK AT THE WELDING ARC IF YOUR EYES ARE NOT SUITABLY PROTECTED.
- ◇ Metal cables with the use get frayed. Always wear adequate protections (heavy gloves, eye protection, etc.)
- ◇ Handle all parts with the greatest caution. Keep your hands and fingers far from gaps, moving gears and similar. Always use approved protective equipment, such as eye protection, heavy gloves and protective footwear.

START UP

- ◇ Never run the engine in confined spaces which are not equipped with adequate ventilation for exhaust gas extraction.
- ◇ Never bring your head, body, arms, legs, feet, hands, fingers near fans or rotating belts.

ENGINE

- ◇ Always loosen the radiator cap very slowly before removing it to allow pressure in the system to dissipate. Coolant should be topped up only when the engine is stopped or idle if hot.
- ◇ Do not fill up fuel tank when the engine is running, mainly if it is hot, to avoid ignition of fires in case of fuel spilling.
- ◇ Never check or adjust the fan belt tension when the engine is running.
Never adjust the fuel injection pump when the tractor is moving.
- ◇ Never lubricate the tractor when the engine is running.

ELECTRICAL SYSTEMS

- ◇ If it is necessary to use auxiliary batteries, cables must be connected at both sides as follows: (+) to (+) and (-) to (-). Avoid short-circuiting the terminals. **GAS RELEASED FROM BATTERIES IS HIGHLY FLAMMABLE.** During charging, leave the battery compartment uncovered to improve ventilation. Avoid checking the battery charge by means of "jumpers" made by placing metallic objects across the terminals. Avoid sparks or flames near the battery area. Do not smoke to prevent explosion hazards.
- ◇ Prior to any service, check for fuel or current leaks. Remove these leaks before going on with the work.
- ◇ Do not charge batteries in confined spaces. Ensure that ventilation is appropriate to prevent accidental explosion hazard due to build-up of gases released during charging.
- ◇ Always disconnect the batteries before performing any type of service on the electrical system.

HYDRAULIC SYSTEMS

- ◇ Some fluid slowly coming out from a very small port can be almost invisible and be strong enough to penetrate the skin. For this reason, **NEVER USE YOUR HANDS TO CHECK FOR LEAKS**, but use a piece of cardboard or a piece of wood to this purpose. If any fluid is injected into the skin, seek medical aid immediately. Lack of immediate medical attention, serious infections or dermatosis may result.
- ◇ Always take system pressure readings using the appropriate gauges.

WHEELS AND TYRES

- ◇ Check that the tyres are correctly inflated at the pressure specified by the manufacturer. Periodically check possible damages to the rims and tyres.
- ◇ Keep off and stay at the tyre side when correcting the inflation pressure.
- ◇ Check the pressure only when the tractor is unloaded and tyres are cold to avoid wrong readings due to over-pressure. Do not reuse parts of recovered wheels as improper welding, brazing or heating may weaken the wheel and make it fail.
- ◇ Never cut, nor weld a rim with the inflated tyre assembled.
- ◇ To remove the wheels, block both front and rear tractor wheels. Raise the tractor and install safe and stable supports under the tractor in accordance with regulations in force.
- ◇ Deflate the tyre before removing any object caught into the tyre tread.
- ◇ Never inflate tyres using flammable gases as they may originate explosions and cause injuries to bystanders.

REMOVAL AND INSTALLATION

- ◇ Lift and handle all heavy components using lifting equipment of adequate capacity. Ensure that parts are supported by appropriate slings and hooks. Use lifting eyes provided to this purpose. Take care of the persons near the loads to be lifted.
- ◇ Handle all parts with great care. Do not place your hands or fingers between two parts. Wear approved protective clothing such as safety goggles, gloves and footwear.
- ◇ Do not twine chains or metal cables. Always wear protection gloves to handle cables or chains.

CONSUMABLES

COMPONENT TO BE FILLED OR TOPPED UP	QUANTITY			RECOMMENDED PRODUCTS	INTERNATIONAL SPECIFICATION
	liters/dm ³	US gal	IMP gal		
Cooling system: without cab: JX 60, JX70	12	3.17	2.64	Water & liquid AMBRA AGRIFLU 50% + 50% (NH 900 A)	-
JX 80, JX90, JX95	14	3.69	3.08		
with cab: JX 60, JX70	14	3.69	3		
JX 80, JX90, JX95	16	4.22	3.52		
Windscreen washer bottle	2	0.53	0.44	Water & cleaning liquid	-
Fuel tank	90	24.3	19.80	Decanted and filtered diesel fuel	-
Engine sump: JX 60, JX 70, JX80:	8.5	2.25	1.87	AMBRA MASTERGOLD SAE 15W - 40 (NH 330H)	API CH-4 ACEA E5
JX 90, JX95:	10.0	2.64	2.20		
Brake control circuit	0.4	0.1	0.09	AMBRA BRAKE LHM Oil (NH 610 A)	ISO 7308
Hydrostatic steering circuit	2.0	0.52	0.44	Oil AMBRA MULTI G (NH 410B)	API GL4 ISO 32/46 SAE 10W-30
Front axle: - axle housing	7.0	1.8	1.54		
- final drives (each):	1.25	0.3	0.28		
Rear transmission (bevel drive and brakes), gearbox, hydraulic lift and PTO	46	12.15	10.12		
Rear final drives (each)	5.3	1.40	1.17		
Front wheel hubs	-	-	-	Grease AMBRA GR9 (NH 710A)	NLGI 2
Grease fittings	-	-	-		

SECTION 10 - ENGINE**Chapter 1 - Engine****CONTENTS**

Operation	Description	Page
	Tools	2
	Engine Troubleshooting	3
10 001 10	Engine R.I.	7

TOOLS

Warning - The operations described in this section can only be carried out with **ESSENTIAL** tools indicated by an **(X)**.

To work safely and efficiently and obtain the best results, it is also necessary to use the recommended specific tools listed below and certain other tools, which are to be made according to the drawings included in this manual.

List of specific tools required for the various operations described in this Section.

380000569 Movable tool for dismantling tractors with bracket **380000500** and adapter plate **380000844**.

ENGINE TROUBLESHOOTING

Problems	Possible Causes	Solutions
Engine does not start.	1. Batteries partially discharged.	Check and recharge batteries. Replace if necessary.
	2. Battery terminal connections corroded or loose.	Clean, inspect and tighten terminal nuts. Replace terminals and nuts if excessively corroded.
	3. Injection pump timing incorrect.	Adjust injection pump timing.
	4. Impurities or water in fuel lines.	Disconnect fuel lines from injection pump and clean thoroughly. If necessary clean and dry the fuel tank.
	5. No fuel in tank.	Fill tank.
	6. Fuel supply pump malfunction.	Check and replace pump if necessary.
	7. Air in fuel system.	Check fuel lines, unions, supply pump, filters and injection pump for air; then bleed the air from the circuit.
	8. Starter motor faulty.	Repair or replace starter motor.
	9. Thermostarter faulty.	Check and replace thermostarter if necessary.
Engine stalls.	1. Idle speed too low.	Adjust idle speed.
	2. Injection pump delivery irregular.	Check injection pump delivery on test bench.
	3. Impurities or water in fuel lines.	Disconnect fuel lines from injection pump and clean thoroughly. If necessary clean and dry the fuel tank.
	4. Fuel filters clogged.	Replace the filter cartridges.
	5. Incorrect valve - rocker arm clearances.	Adjust the clearance between the rocker arms and the valves.
	6. Burnt or cracked valves.	Replace the valves.
	7. Air in fuel system.	Check fuel lines, unions, supply pump, filters and injection pump for air; then bleed the air from the circuit.
	8. Injection pump drive mechanism damaged.	Replace damaged parts.

(continued)

ENGINE TROUBLESHOOTING

(cont)

Problems	Possible Causes	Solutions
Engine overheating.	1. Coolant pump malfunction.	Overhaul pump and replace if necessary.
	2. Thermostat faulty.	Replace the thermostat.
	3. Radiator inefficient.	Remove internal deposits by flushing. Check for leaks and repair.
	4. Deposits in cylinder head and crankcase coolant passages.	Flush out coolant system.
	5. Coolant pump and fan drive belt slack.	Check and adjust belt tension.
	6. Coolant level low.	Top up expansion tank with specified coolant mixture.
	7. Incorrect engine timing.	Check and adjust engine timing.
	8. Injection pump calibration incorrect - delivering too much or too little fuel.	Calibrate pump on test bench to values specified in calibration tables.
	9. Air filter clogged.	Clean filter unit and replace filter element if necessary.
Engine lacks power and runs unevenly.	1. Injection pump timing incorrect.	Adjust injection pump timing.
	2. Auto advance regulator in injection pump damaged.	Overhaul injection pump and adjust on test bench to values specified in calibration table.
	3. Control valve journal worn.	Overhaul injection pump and adjust on test bench to values specified in calibration table.
	4. Injection pump delivery irregular.	Overhaul injection pump and adjust on test bench to values specified in calibration table.
	5. All-speed governor damaged.	Overhaul injection pump and adjust on test bench to values specified in calibration table.
	6. Injectors partially obstructed or damaged.	Clean and overhaul injectors and adjust pressure setting.
	7. Impurities or water in fuel lines.	Disconnect fuel lines from injection pump and clean thoroughly. If necessary clean and dry the fuel tank.

(continued)

ENGINE TROUBLESHOOTING

(cont)

Problems	Possible Causes	Solutions
Engine produces abnormal knocking noises.	8. Fuel supply pump damaged.	Replace fuel supply pump.
	9. Incorrect valve - rocker arm clearances.	Adjust the clearance between the rocker arms and the valves.
	10. Cylinder compression low.	Test compression and overhaul engine if necessary.
	11. Air filter clogged.	Clean filter unit and replace filter element if necessary.
	12. Tie-rod in linkage between accelerator and injection pump incorrectly adjusted.	Adjust to correct length.
	13. Fast idling speed screw on injection pump incorrectly adjusted.	Adjust fast idling speed screw.
	1. Injectors partially obstructed or damaged.	Clean and overhaul injectors and adjust pressure setting.
	2. Impurities accumulating in fuel lines.	Clean fuel lines and replace severely dented pipes; clean injection pump if necessary.
	3. Injection pump timing incorrect.	Adjust injection pump timing.
	4. Crankshaft knocking due to excessive play in one or more main or big-end bearings or excessive endfloat.	Re-grind crankshaft journals and crankpins. Fit oversize shell bearings and thrust washers.
5. Crankshaft out of balance.	Check crankshaft alignment and balance; replace if necessary.	
6. Flywheel bolts loose.	Replace any bolts that have worked loose and tighten all bolts to the specified preliminary and angular torque values.	
7. Connecting rod axes not parallel.	Straighten connecting rods, check axes parallelism; replace con rods if necessary.	
8. Pistons knock due to excessive wear.	Rebore cylinder liners and fit oversize pistons.	
9. Noise caused by excessive play of gudgeon pins in small-end and piston bushings. Loose fit of small-end bushing.	Fit oversize gudgeon pin, rebore piston seats and small-end bushings. Replace with new bushings.	
10. Excessive tappet / valve noise.	Check for broken springs or excessive play between valve stems and guides, cam followers and bores; adjust valve clearances.	

(continued)

ENGINE TROUBLESHOOTING

(cont)

Problems	Possible Causes	Solutions
Engine produces excessive black or dark grey smoke.	1. Maximum delivery of injection pump too high.	Calibrate pump on test bench to values specified in calibration tables.
	2. Injection pump delivery excessively retarded or automatic advance regulator damaged.	Adjust injection pump timing or check automatic advance regulator.
	3. Injection pump delivery excessively advanced.	Adjust injection pump timing.
	4. Injectors partially or totally obstructed or incorrectly adjusted.	Clean and overhaul injectors and adjust pressure setting; replace if necessary.
	5. Air filter clogged.	Clean filter unit and replace filter element if necessary.
	6. Loss of engine compression due to: <ul style="list-style-type: none"> - piston rings sticking; - cylinder liner wear; - worn or incorrectly adjusted valves. 	Replace damaged parts or, if necessary, overhaul the engine.
	7. High-pressure fuel lines damaged.	Inspect and replace if necessary.
Blue, grey-blue or grey-white smoke.	1. Injection pump delivery excessively retarded or automatic advance regulator damaged.	Adjust injection pump timing or check automatic advance regulator.
	2. Injectors obstructed or damaged.	Clean, overhaul and calibrate injectors, replace if necessary.
	3. Oil leaking past piston rings due to sticking rings or cylinder liner wear.	Replace damaged parts or, if necessary, overhaul the engine.
	4. Oil leaking through the inlet valve guides due to guide or valve stem wear.	Overhaul cylinder head.
	5. Engine does not reach correct operating temperature (thermostat faulty).	Replace the thermostat.
Engine runs on after switching off.	1. Engine stop electromagnet damaged.	Replace electromagnet.
	2. All-speed governor damaged.	Overhaul injection pump and adjust on test bench to values specified in calibration table.

Op. 10 001 10
ENGINE R.I.**DANGER**

Lift and handle all heavy parts using suitable lifting equipment.

Make sure that assemblies or parts are supported by means of suitable slings and hooks. Check that no one is in the vicinity of the load to be lifted.

**CAUTION**

Always use appropriate tools to align fixing holes. NEVER USE FINGERS OR HANDS.

1. Disconnect the battery negative lead (1).
2. Drain the oil from the transmission-gearbox housing.
3. Drain the cooling system.

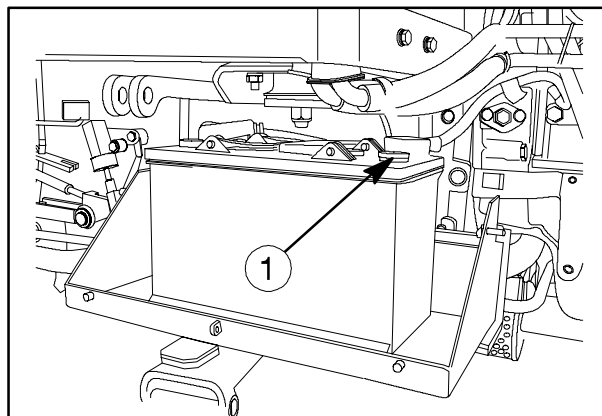

1

4. Remove the exhaust pipe, attach lifting chains (2) to the bonnet (1) and attach the chain to the hoist.

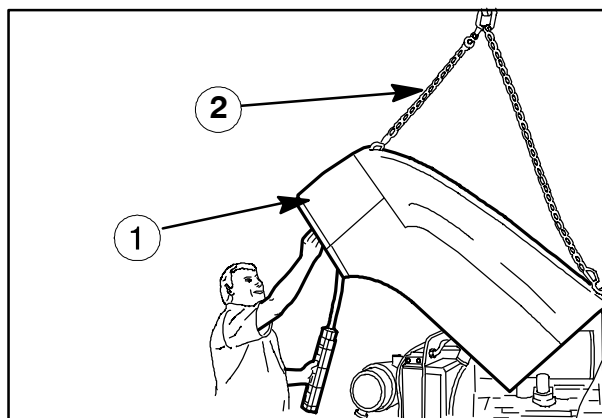

2

5. Disconnect the electrical connection (1) of bonnet.

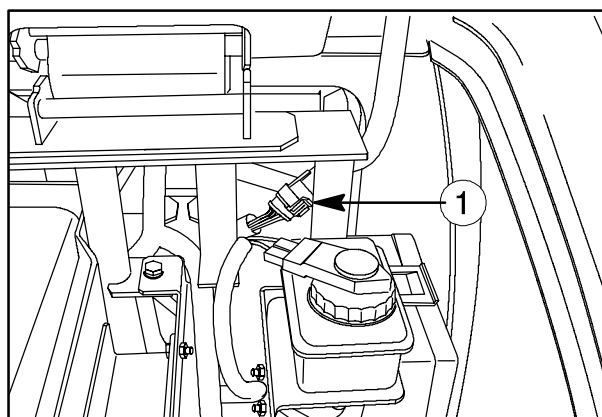

3

6. Detach the gas struts (1) from the bonnet.

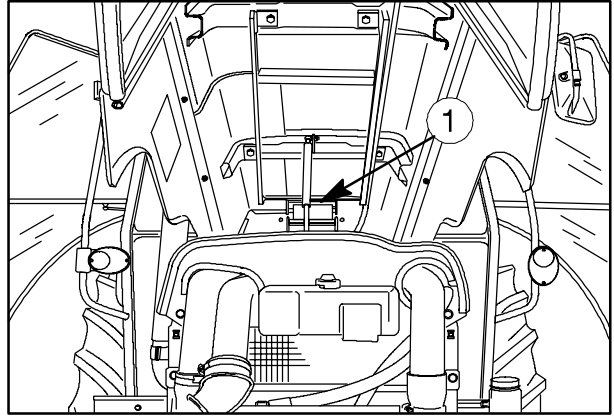

4

7. Remove the four bonnet hinge bolts (1) and lift the bonnet clear.

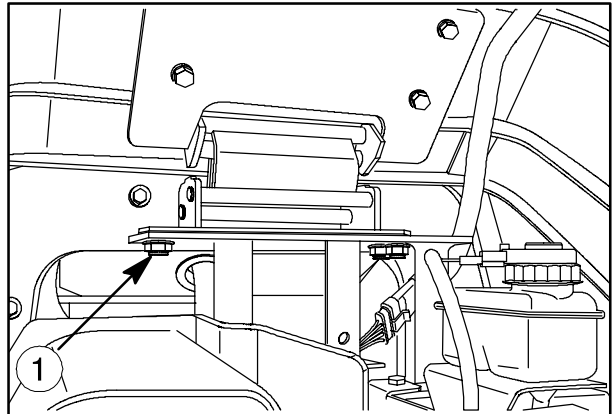

5

8. Remove the three retaining bolts (1) and the guard (2) on the right-left hand side of the fan.

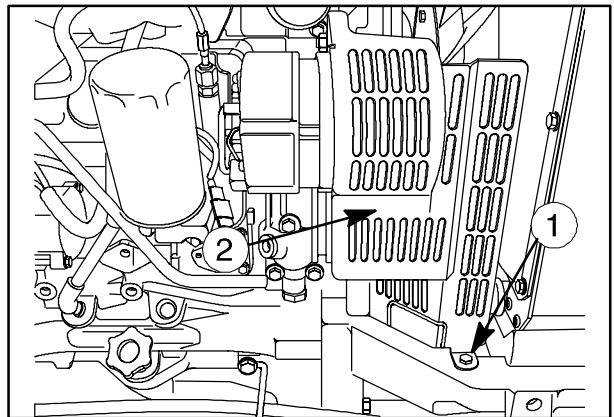

6

9. Unscrew the nut (1) from the weight retaining pin. Remove the weights from the front support.

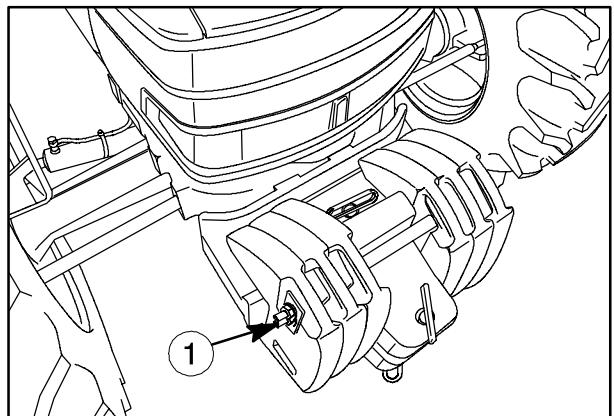

7

10. Unscrew the front central and rear retaining bolts on the front axle shaft guard, then remove the guard (1).

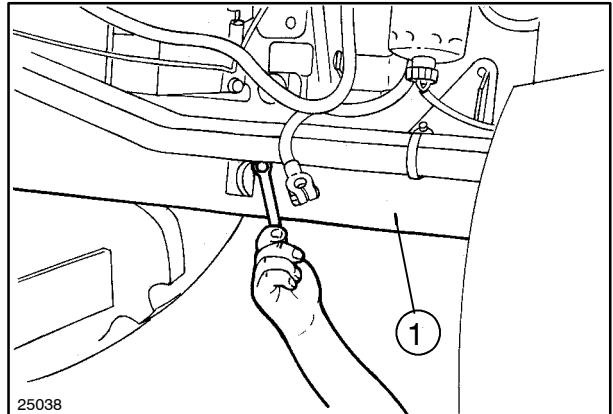

8

11. Remove the circlip (2) and move the front sleeve (1) in the direction indicated by the arrow until it is released from the groove on the front axle.

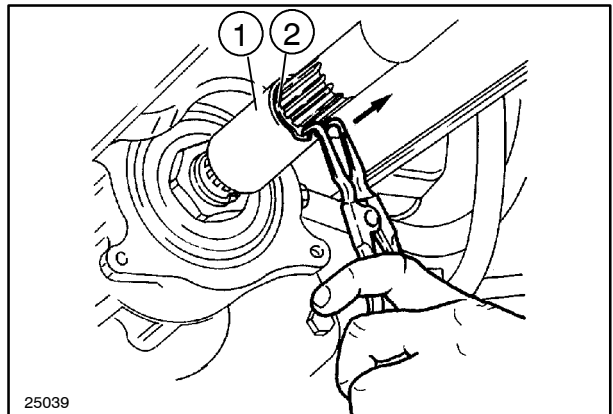

9

12. Remove the circlip (2) and move the rear sleeve (1) in the direction indicated by the arrow until it is released from the groove on the drive.

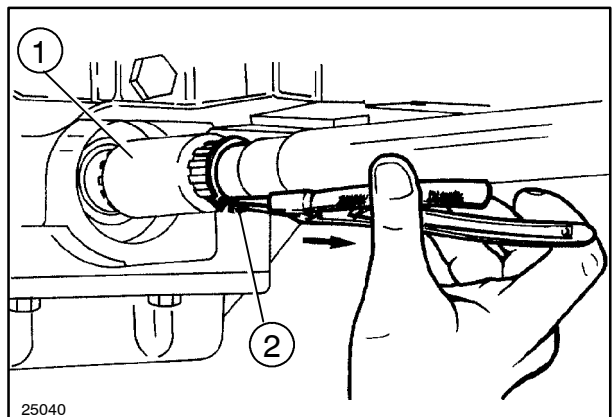

10

13. Remove the propeller shaft central support (1) retaining bolts and extract the shaft together with the support.

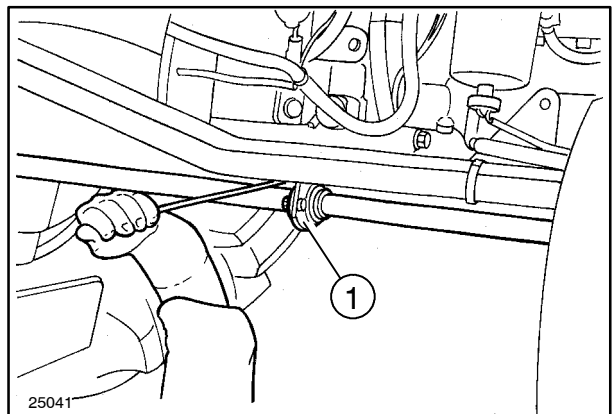

11

14. Disconnect the pressure pipe connection (1) of the lift pump.

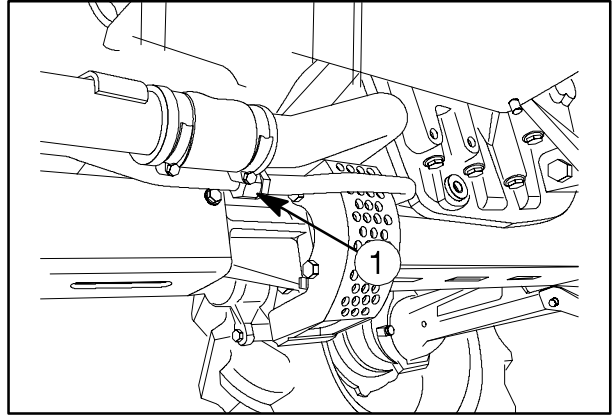

12

15. Disconnect the delivery lines of both hydraulic lift pump (1) and hydrostatic steering pump (2).

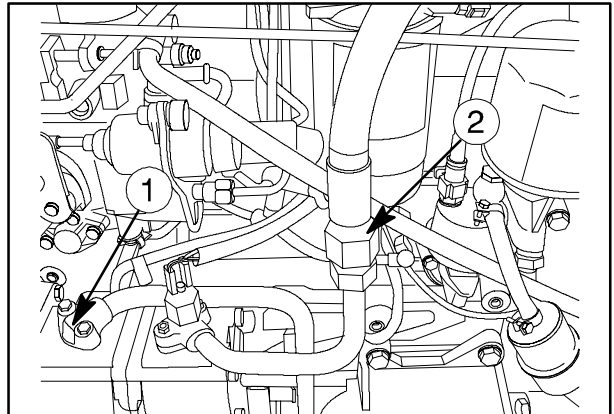

13

16. Detach the cab heating pipes (1) and (2).

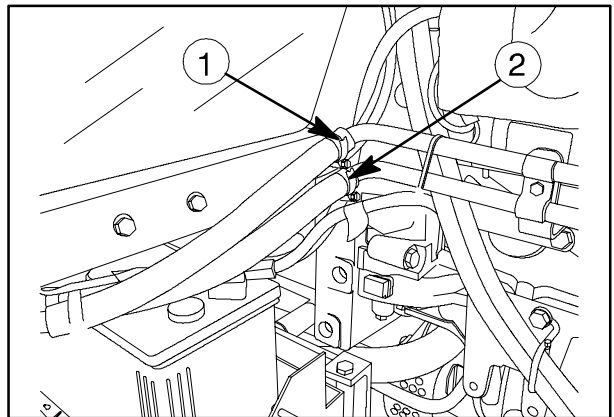

14

17. Detach the cab air-conditioning pipes (1) and (2).

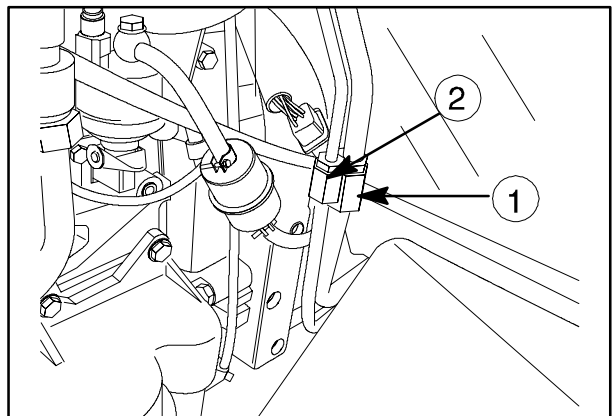

15

18. Extract the plastic fasteners (2) and detach the diesel recovery pipe (3) and delivery pipe (4) to the diesel pump (1).

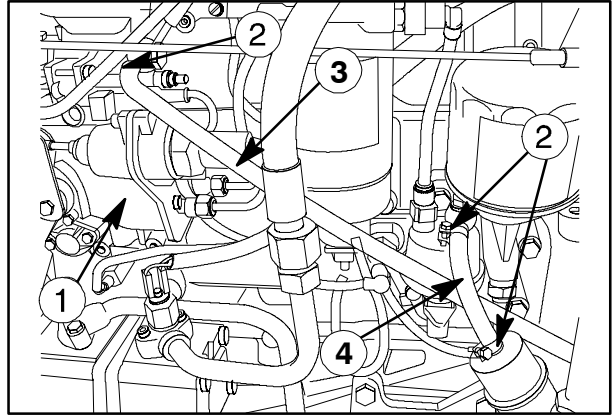

16

19. Remove two metal clamps (1) and the rigid pipe of drawing oil from the transmission housing via lift pump.

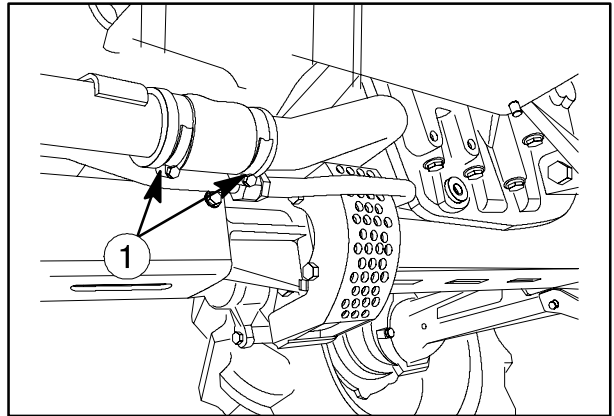

17

20. Remove the electrical connection from the brake fluid reservoir and take the brake fluid reservoir (1) from the bracket.

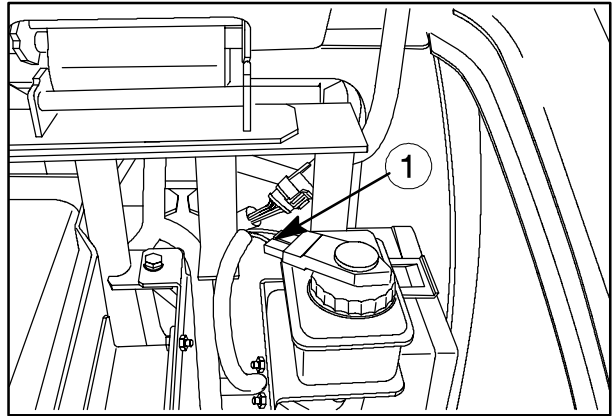

18

21. Disconnect the steering oil delivery and return hoses (1) and (2). Disconnect the steering cylinder lines (3) and (4).

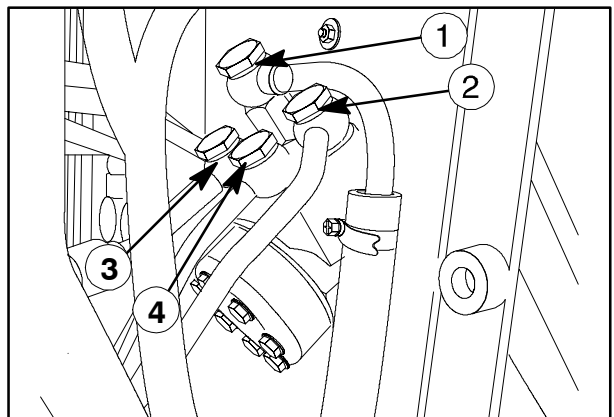

19

Thank you so much for reading.
Please click the “Buy Now!”
button below to download the
complete manual.



After you pay.

You can download the most
perfect and complete manual in
the world immediately.

Our support email:

ebooklibonline@outlook.com