

# MD72, MD82, MD92 Disc Mowers

## Service Manual

84207378 5/09  
1st Printing



# **MD72, MD82, MD92 SERVICE MANUAL CONTENTS**

**SECTION 00 - GENERAL INFORMATION**

**SECTION 35 - HYDRAULICS**

**SECTION 58 - DRIVELINES**

**SECTION 88 - OPTIONAL EQUIPMENT**

**SECTION 90 - DECALS**

The sections used through out all Case IH product Service manuals may not be used for each product. Each Service manual will be made up of one or several books. Each book will be labeled as to which sections are in the overall Service manual and which sections are in each book.

The sections listed above are the sections utilized for the MD72, MD82, MD92.

**SECTION 00 - GENERAL INFORMATION**

**Chapter 1 - General Information**

**CONTENTS**

<b>Section</b>	<b>Description</b>	<b>Page</b>
	Precautionary Statements .....	2
	General Information .....	3
	Before Using the New Machine .....	3
	After 8 Hours of Operation .....	3
	Tractor Requirements .....	4
	Attaching the Mower to the Tractor .....	5
	Model MD72 .....	5
	Attaching the Mower to the Tractor .....	9
	Model MD82 and MD92 .....	9
	Lowering the Cutter Bar for Field Operation .....	15
	Transporting the Mower .....	16
	Removing the Mower from the Tractor .....	16
	Storing the Mower .....	18
	Specifications .....	19

# PRECAUTIONARY STATEMENTS

## PERSONAL SAFETY

Throughout this manual and on machine decals, you will find precautionary statements (“**DANGER**”, “**WARNING**”, and “**CAUTION**”) followed by specific instructions. These precautions are intended for the personal safety of you and those working with you. Please take the time to read them.



**DANGER**



This word “**DANGER**” indicates an immediate hazardous situation that, if not avoided, will result in death or serious injury. The color associated with Danger is RED.

M1169



**WARNING**



This word “**WARNING**” indicates a potentially hazardous situation that, if not avoided, could result in death or serious injury. The color associated with Warning is ORANGE.

M1170



**CAUTION**



This word “**CAUTION**” indicates a potentially hazardous situation that, if not avoided, may result in minor or moderate injury. It may also be used to alert against unsafe practices. The color associated with Caution is YELLOW.

M1171

---

**FAILURE TO FOLLOW THE “DANGER”, “WARNING”, AND “CAUTION” INSTRUCTIONS MAY RESULT IN DEATH OR SERIOUS BODILY INJURY.**

## MACHINE SAFETY

The precautionary statement (“**NOTICE**”) is followed by specific instructions. This statement is intended for machine safety.

**NOTICE:** The word “**NOTICE**” is used to inform the reader of something he needs to know to prevent minor machine damage if a certain procedure is not followed.

## INFORMATION

**NOTICE:** Instructions used to identify and present supplementary information.

## GENERAL INFORMATION



**To prevent injury to bystanders, this mower is not intended for roadside or municipal mowing. This mower is intended for agricultural use only. Failure to comply will result in death or serious injury.**

M1215

On Case IH equipment, left and right are determined by standing behind the unit, looking in the direction of travel.

The serial number plate, 1, for the Models MD72, MD82, and MD92 is located on the left side of the main frame. Record this serial number in the space listed below.

Serial Number: \_\_\_\_\_

Give your dealer the model and serial number of your disc mower when ordering parts. Always order genuine Case IH parts from your Case IH dealer.

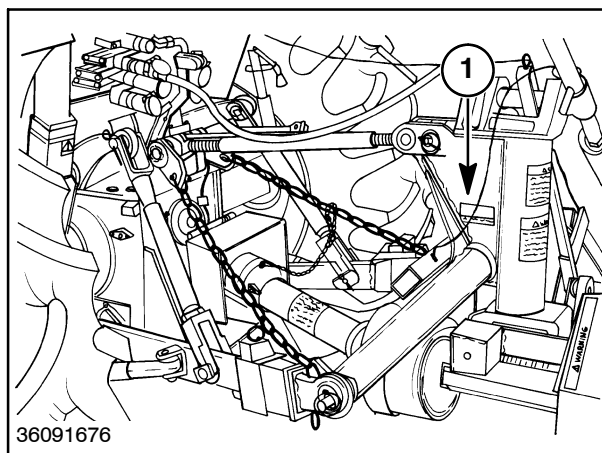

1

### BEFORE USING THE NEW MACHINE

1. Thoroughly read and understand this manual. Pay particular attention to all safety precautions.
2. Check all grease fittings and the gearbox oil levels to insure the machine has been lubricated as recommended in this manual.
3. Check all adjustments to insure they have been made as detailed in the "Maintenance" section of this manual.

### After 8 Hours Of Operation

1. Check for loose hardware and tighten any loose bolts.
2. Visually check the entire cutter bar for leakage and correct any leakage before operation.
3. Check mower drive belts for correct tension, and readjust as required.

## Tractor Requirements

The Model MD72 disc mower is designed to fit tractors with 540 rpm PTOs with standard ASAE Category I three-point hitches.

The tractor must also have adjustable sway bars or a means of locking the lower lift arms from moving sideways.

For the MD72 disc mower, the tractor front axle weight should be 782 kg (1725 lbs) or greater prior to attaching the disc mower. This is for tractors with a wheel base range of 78 inch to 84 inch. Add additional weight if required to achieve 782 kg (1725 lbs) or greater.

The tractor must also be equipped with one remote hydraulic circuit with a minimum of 104 bar (1500 psi) and a maximum of 193 bar (2800 psi).

The tractor should be 45-horsepower minimum for the Model MD72, 55-horsepower minimum for the Model MD82, and 60-horsepower for the Model MD92. Insufficient tractor horsepower may cause stripping and poor cutting.

The tractor must have adequate ballasting, wheel spacing, and tire spacing to be stable on hillsides. Too small a tractor may create a stability concern when mowing in hilly conditions.

—————  **WARNING**  —————

**A tractor with an enclosed cab is recommended when operating a rotary disc cutting machine. Failure to comply could result in death or serious injury.**

M1183

---

## ATTACHING THE MOWER TO THE TRACTOR

### Model MD72

1. Clean all paint or rust from the hitch pins.
2. Attach the plate on the end of the check chains to the outer end of frame hitch pins, 1, as required to clear obstructions on the tractor. Install the check chain plates before attaching the tractor lower links.
3. Back the tractor to the mower and attach the lower links, 2, to the outer end of the frame hitch pins. Secure the links with linchpins. Install the linchpins from the top down.

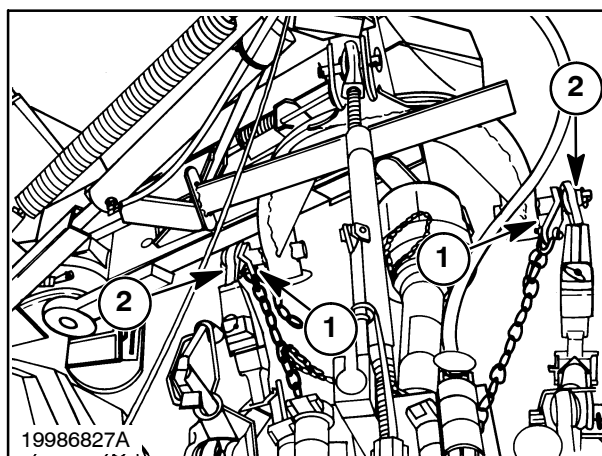

2

4. Attach the top link to the tractor, 1, using the pin provided with the tractor top link.
5. Attach the top link to the mower, 2, in the front hole using the pin provided with the mower.

**NOTICE:** If necessary, the top link may be mounted in the rear hole on the mower to allow greater top link length range.

6. Attach the check chain plates to the tractor at a top link mounting position, 3, with the pin provided.

**NOTICE:** If the check chains interfere with or could damage the tractor PTO shield, relocate the check chain plates to the opposite end of the mower frame hitch pins, or attach to a different location on the tractor.

**NOTICE:** It may be necessary to position the tractor drawbar to the side or remove it to prevent interference with the check chains or PTO shaft.

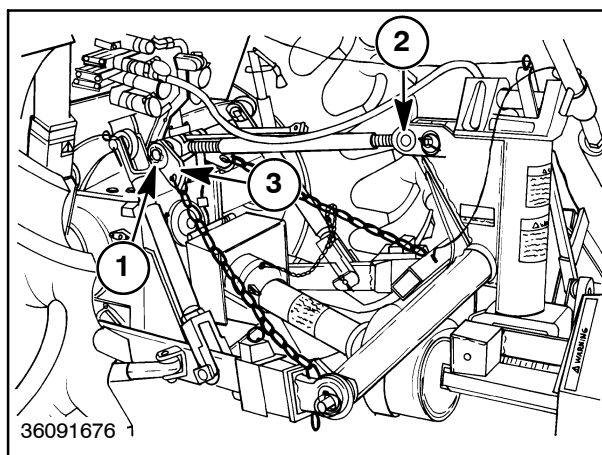

3

- The PTO assembly must be fitted to the tractor being used. The tubes must overlap at least 102 mm (4 in). At the same time, the tubes, 1 and 2, must be short enough so they do not bottom out.

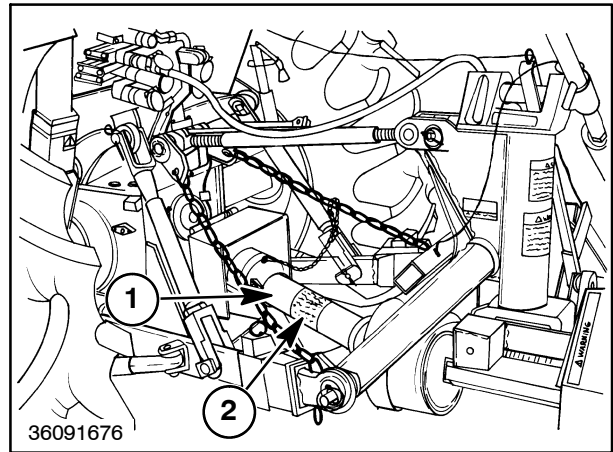

4

The assembly must also be long enough so it does not pull apart when the breakaway system, 1, operates.

**NOTICE:** Most tractors will not require the PTO to be shortened.

Separate the front and rear PTO shafts. Connect the front half to the tractor PTO and the rear half to the disc mower input shaft. Raise and lower the machine to find the position where the PTO would be the shortest. Hold the shafts side by side and mark the length to provide 10 mm (3/8 in) clearance between the end of the shafts and the yoke.

Measure how much is to be cut from your marks. Cut off an equal length from the front and rear plastic shield. Shorten the PTO telescoping shafts the same amount as the plastic shields.

**NOTICE:** Remove the grease sleeve from the rear half of the PTO shaft before shortening the tube.

Remove the burrs from the shaft ends with a file or grinder. Clean out the metal chips and filings. Apply grease to the inside of the outer telescoping tube before assembly. Reinstall the grease sleeve on the end of the rear half of the PTO shaft.

Check to be sure the shafts do not bottom out, and operate the breakaway to be sure they do not come apart.

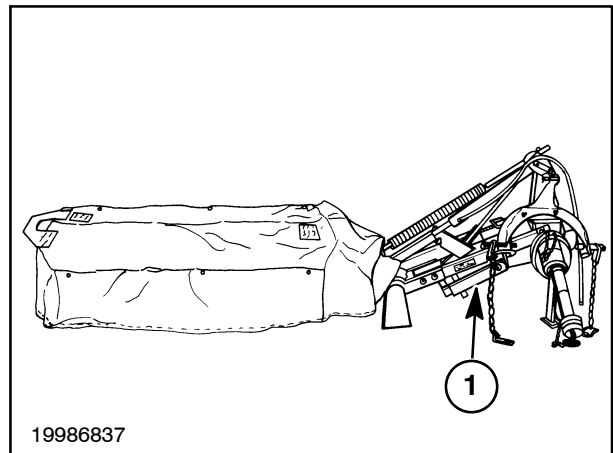

5



8. Attach the PTO assembly to the tractor.
9. Connect the hydraulic hose to the tractor, preferably to a valve section with a float position. Select the appropriate port to allow engaging the float position when lowering.

**NOTICE:** Check the tractor operator's manual for instructions on which outlet to use for single acting cylinders.

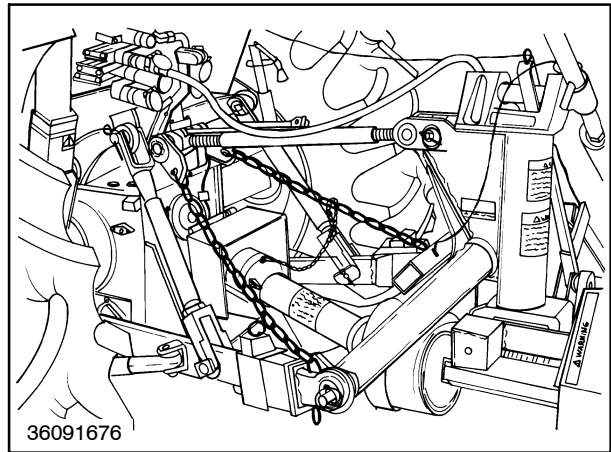

6

10. Raise the mower with the tractor three-point hitch. Remove pin, 2, and remove the jack stand, 1. Attach the jack stand to the mower frame by sliding the jack stand slots over lugs, 3, on the frame.

**NOTICE:** The pin which is attached to the jack stand with a cable will be installed in the flotation system later.

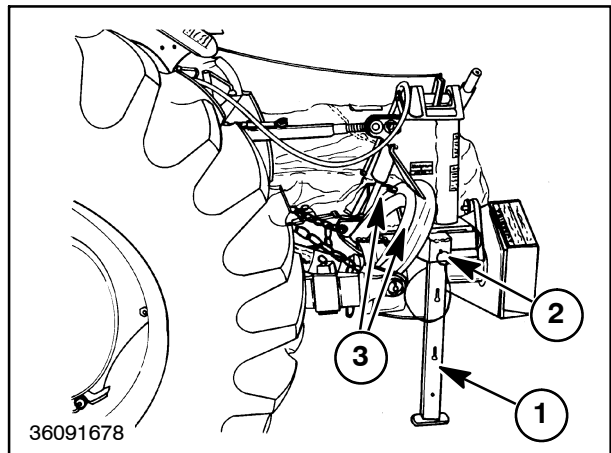

7

11. Level the tractor lower lift links from side to side. Adjust and lock the sway bars or whatever system the tractor has to remove as much side movement as possible.

**NOTICE:** The tractor lower links should be positioned straight behind the tractor, or have minimal offset. Excessive offset in either direction may cause damage to the mower PTO drive shaft due to excessive operating angles or contact with hitch pins, and will also put "lead" or "lag" into the cutter bar resulting in reduced cutting width and breakaway performance.

Adjust the limit chain length so the hitch pins, 1, are as close to (but not less than) 609 mm (24 in) as possible from the ground when the mower is supported by the limit chains.

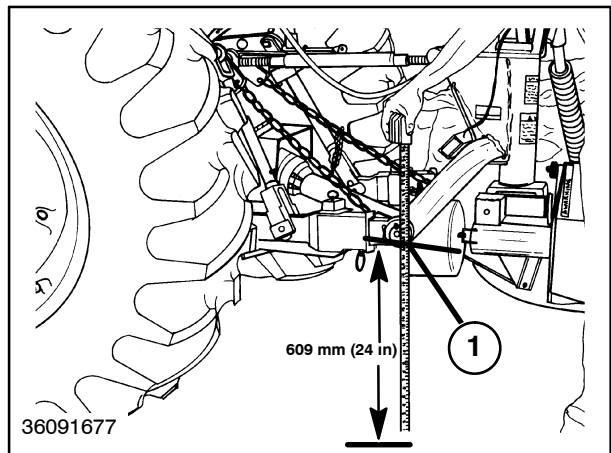

8

**NOTICE:** If the high stubble kit is installed on the mower, adjust frame height to 660 mm (26 in) from ground in order to provide adequate flotation.

12. Fold the front half of the cutter bar curtain, 1, rearward. Secure the curtain with the rubber tie strap, 2. Flip the cutter bar up-stop channel, 3, toward the cutter bar and against the brace.

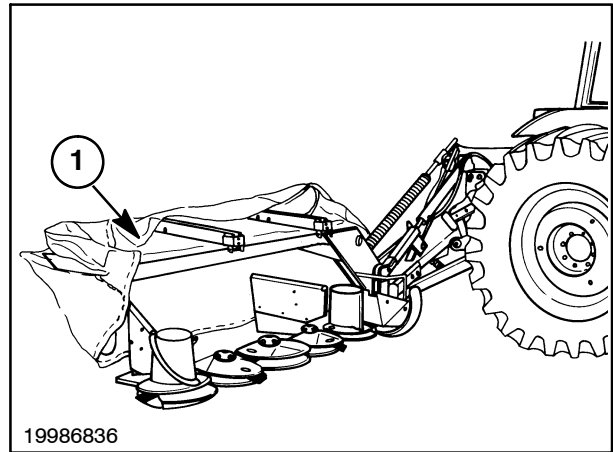

9

13. Raise the cutter bar with the tractor hydraulics. Raise it high enough to engage the transport latch, 1.

**NOTICE:** Before raising the cutter bar with the hydraulic cylinder, make sure there is adequate clearance between the machine and the tractor. The top link may have to be lengthened for the cutter bar to clear the cab.

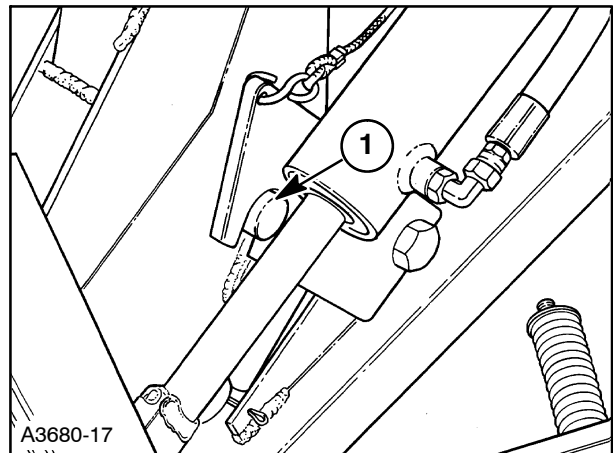

10

14. Install the pin, 1, which is attached to the jack stand, 2, in the upper flotation spring rod at 3. The pin has two detent balls and is properly installed when detents are on either side of the flotation spring rod.

**NOTICE:** If the pin is inserted too far, the retaining ring may be knocked off and the pin may be lost, causing loss of flotation.

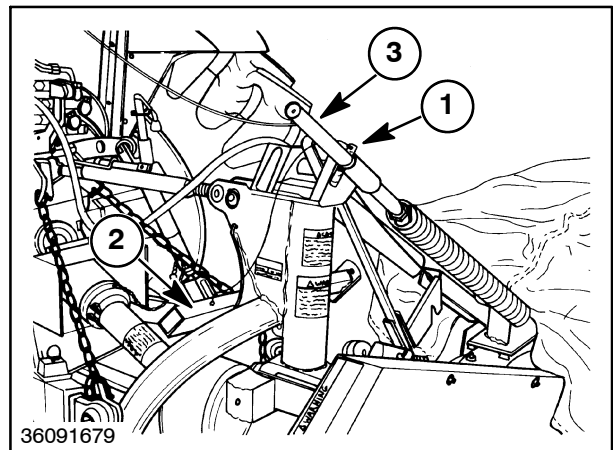

11

## ATTACHING THE MOWER TO THE TRACTOR

### Models MD82 and MD92

Prior to installing the mower onto the tractor, the mower must be adjusted to match the tractor. Depending on the size of the tractor and the wheel spacing, it may be necessary to move the hex-shaped lower lift pins, 1.

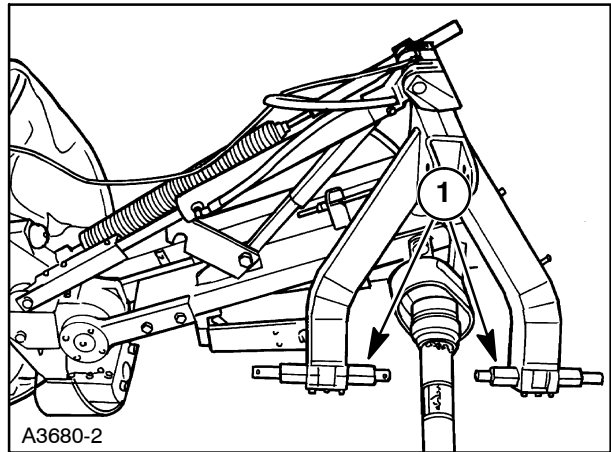

12

**NOTICE:** Ideally a 102 mm (4 in) clearance should be held between the outside edge of the tractor tire and the mower inner shield for a full cut of the cutter bar at all times.

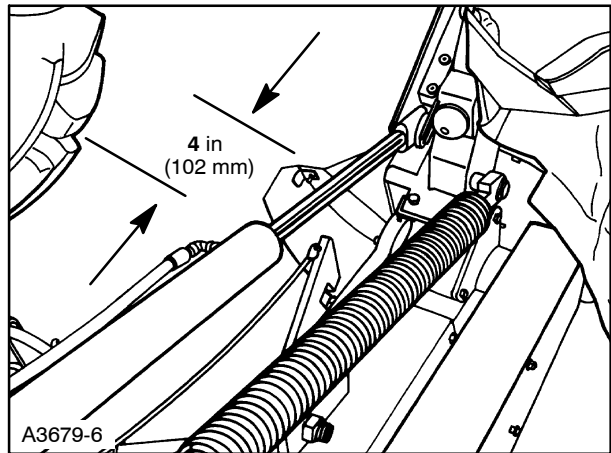

13

The hex-shaped hitch pins mounted on the bottom of the main frame arms can be moved to position the mower behind the tractor for different tread widths. To do this, loosen the four clamp bolts, 1, on each main frame arm until the hitch pins can be moved. Retighten the clamp bolts evenly so that both sides of the clamp block, 2, have equal clearance to the main frame arm.

**NOTICE:** Always position the hitch pins so that the long round pin is towards the outside of the main frame. Do not position the long round pins inside the main frame, or damage to the mower PTO drive shaft could occur.

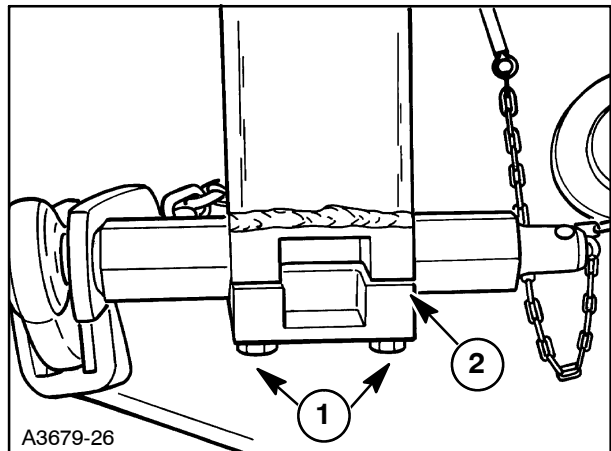

14

## SECTION 00 - GENERAL INFORMATION - CHAPTER 1

Measure from the center of the tractor to the right side of the right tire.

For tractors that measure 940 mm (37 in) or less, position both hitch pins to the right so that only the round pin protrudes on the left side of the main frame arms. This will position the mower towards the left, moving the cutter bar closer to the right side tractor tire.

**NOTICE:** The tractor lower link arms may need to be offset slightly to the left to prevent the mower PTO shaft from contacting the inner end of the left hitch pin.

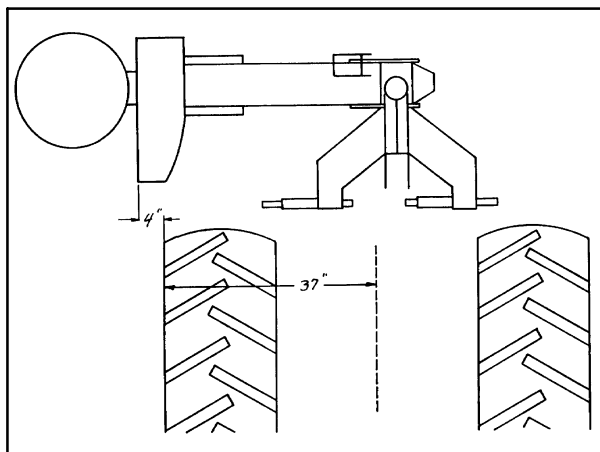

15

For tractors that measure 1016 mm (40 in), center the hitch pins in the main frame arm.

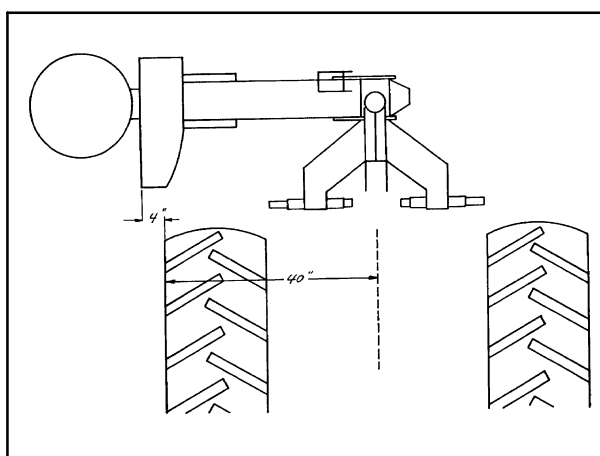

16

For tractors that measure 1092 mm (43 in), position the hitch pins to the left so that only the round pin protrudes on the right side of the main frame arms. This will position the mower towards the right, away from the right side tractor tire.

**NOTICE:** The tractor lower link arms may need to be offset slightly to the right to prevent the mower PTO shaft from contacting the inner end of the right hitch pin.

For tractors that measure more than 1092 mm (43 in), the tractor lower link arm sway bars or check chains can be adjusted to further offset the mower to the right, or the right side tire should be moved inward.

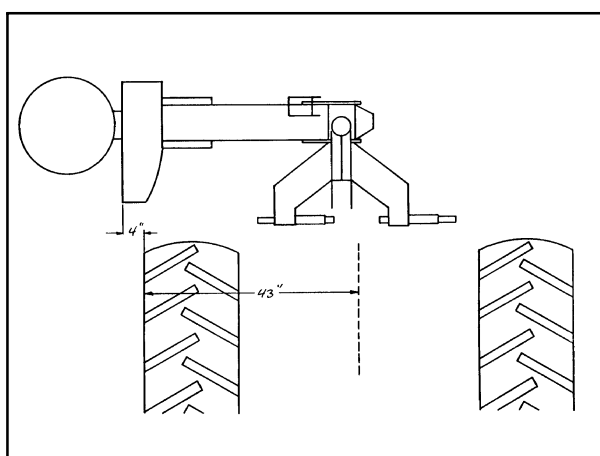

17

**NOTICE:** The tractor lower links should be positioned straight behind the tractor, or have minimal offset. Excessive offset in either direction may cause damage to the mower PTO drive shaft due to excessive operating angles or contact with hitch pins, and will also put "lead" or "lag" into the cutter bar resulting in reduced cutting width and breakaway performance.

## SECTION 00 - GENERAL INFORMATION - CHAPTER 1

1. Clean all paint or rust from the hitch pins.
2. Attach the plate on the end of the check chains to the inner or outer end of frame hitch pins, 1, as required to clear obstructions on the tractor. If installing on the outer end of the hitch pins, install the check chain plates before attaching the tractor lower links.
3. Back the tractor to the mower and attach the lower links, 2, to the outer end of the frame hitch pins. Secure the links with linchpins. Install the linchpins from the top down.

**NOTICE:** Attach the tractor lower links to the outside pins only; do not attach the lower links to the pins inside the mower frame or damage to the mower PTO drive shaft could occur.

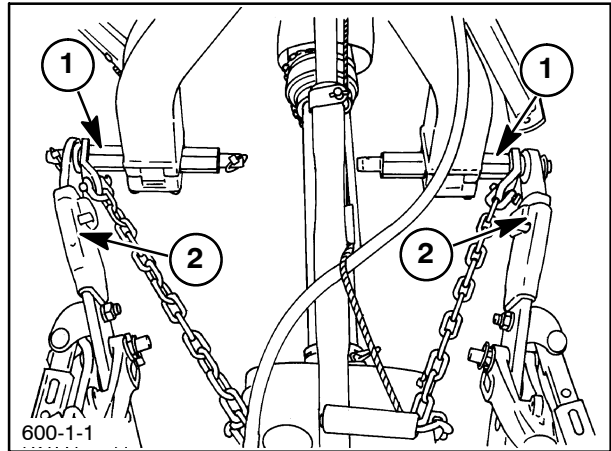

18

4. Attach the top link to the tractor, 1, using the pin provided with the tractor top link.
5. Attach the top link to the mower, 2, in the front hole using the pin provided with the mower.

**NOTICE:** If necessary, the top link may be mounted in the rear hole on the mower to allow greater top link length range.

6. Attach the check chain plates to the tractor at a top link mounting position, 3, with the pin provided.

**NOTICE:** If the check chains interfere with or could damage the tractor PTO shield, relocate the check chain plates to the opposite end of the mower frame hitch pins, or attach to a different location on the tractor.

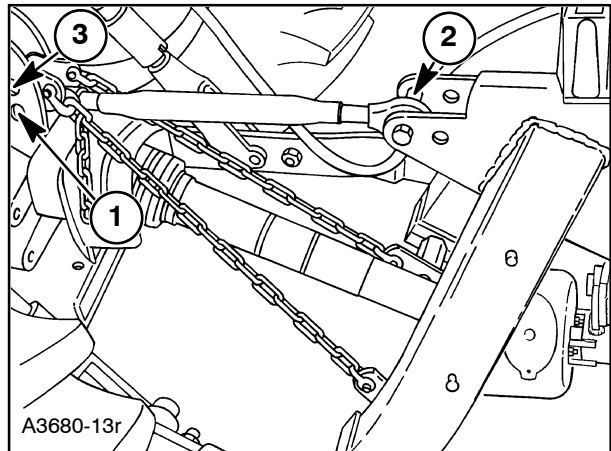

19

**NOTICE:** It may be necessary to position the tractor drawbar to the side or remove it to prevent interference with the check chains or PTO shaft.

7. The PTO assembly must be fitted to the tractor being used. The tubes must overlap at least 102 mm (4 in). At the same time, the tubes, 1 and 2, must be short enough so they do not bottom out.

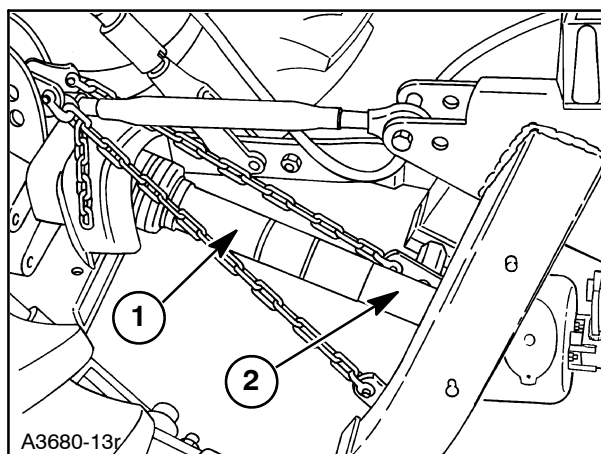

20

The assembly must also be long enough so it does not pull apart when the breakaway system, 2, operates.

**NOTICE:** Most tractors will not require the PTO to be shortened.

Separate the front and rear PTO shafts. Connect the front half to the tractor PTO and the rear half to the disc mower input shaft. Raise and lower the machine to find the position where the PTO would be the shortest. Hold the shafts side by side and mark the length to provide 10 mm (3/8 in) clearance between the end of the shafts and the yoke.

Measure how much is to be cut from your marks. Cut off an equal length from the front and rear plastic shield. Shorten the PTO telescoping shafts the same amount as the plastic shields.

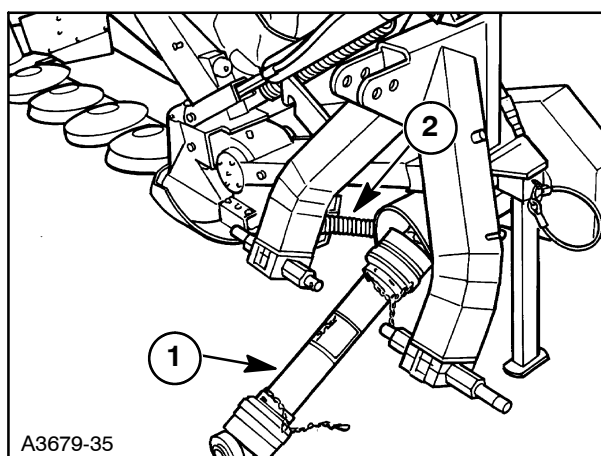

21

**NOTICE:** Remove the grease sleeve from the rear half of the PTO shaft before shortening the tube.

Remove the burrs from the shaft ends with a file or grinder. Clean out the metal chips and filings. Apply grease to the inside of the outer telescoping tube before assembly. Reinstall the grease sleeve on the end of the rear half of the PTO shaft.

Check to be sure the shafts do not bottom out, and operate the breakaway to be sure they do not come apart.

8. Attach the PTO assembly to the tractor.
9. Connect the hydraulic hose to the tractor, preferably to a valve section with a float position. Select the appropriate port to allow engaging the float position when lowering.

**NOTICE:** Check the tractor operator's manual for instructions on which outlet should be used for single acting cylinders.

10. Raise the mower with the tractor three-point hitch. Remove pin, 2, and remove the jack stand, 1. Attach the jack stand to the mower frame by sliding the jack stand slots over lugs, 3, on the frame.

**NOTICE:** The pin which is attached to the jack stand with a cable will be installed in the flotation system later.

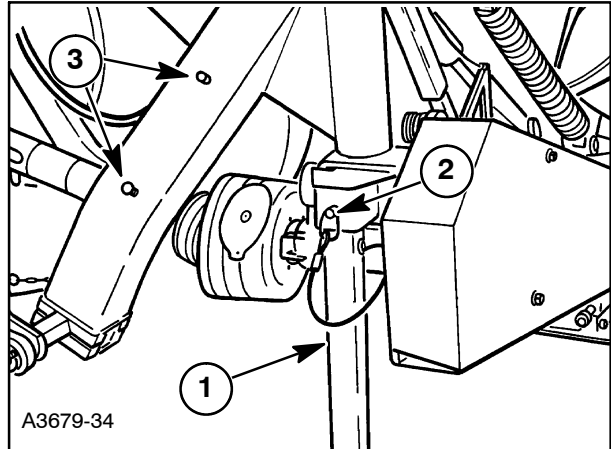

22

11. Level the tractor lower lift links from side to side. Adjust and lock the sway bars or whatever system the tractor has to remove as much side movement as possible.

**NOTICE:** The tractor lower links should be positioned straight behind the tractor, or have minimal offset. Excessive offset in either direction may cause damage to the mower PTO drive shaft due to excessive operating angles or contact with hitch pins, and will also put "lead" or "lag" into the cutter bar resulting in reduced cutting width and breakaway performance.

Adjust the limit chain length so the hitch pins, 1, are as close to (but not less than) 457 mm (18 in) as possible from the ground when the mower is supported by the limit chains.

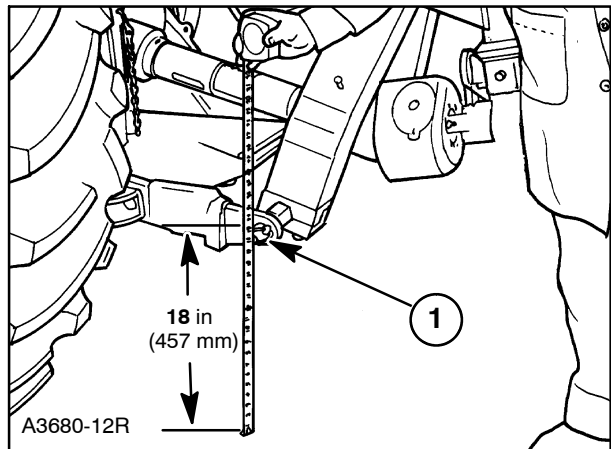

23

**NOTICE:** If the high stubble kit is installed on mower, adjust frame height to 508 mm (20 in) from ground in order to provide adequate flotation.

12. Fold the front half of the cutter bar curtain, 1, rearward. Secure the curtain with the rubber tie strap, 2. Flip the cutter bar up-stop channel, 3, toward the cutter bar and against the brace.

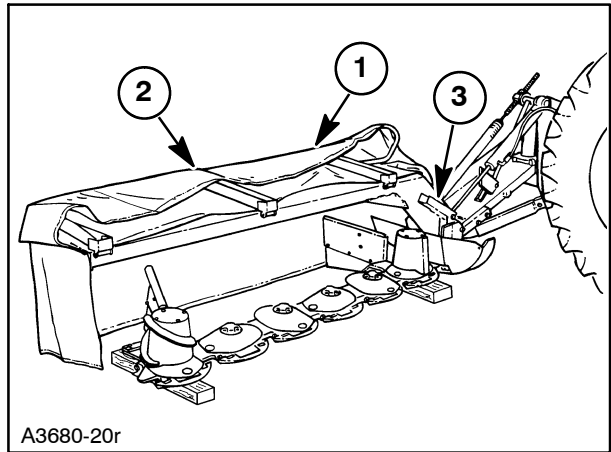

13. Raise the cutter bar with the tractor hydraulics. Raise it high enough to engage the transport latch, 1.

24

**NOTICE:** Before raising the cutter bar with the hydraulic cylinder, make sure there is adequate clearance between the machine and the tractor. The top link may have to be lengthened for the cutter bar to clear the cab.

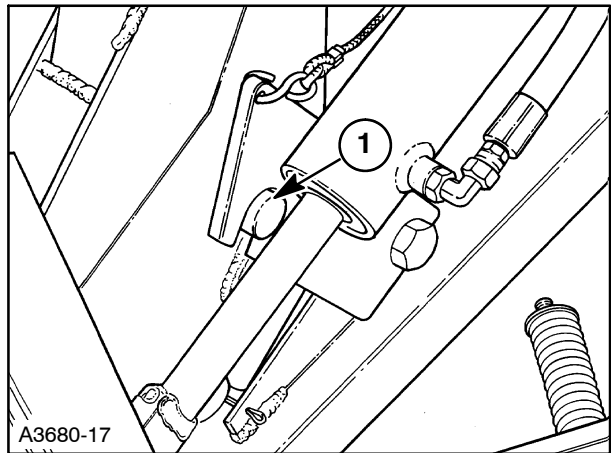

14. Install the pin which is attached to the jack stand, 2, in the upper flotation spring rod at 1. The pin has two detent balls and is properly installed when detents are on either side of the flotation spring rod.

25

**NOTICE:** If the pin is inserted too far, the retaining ring may be knocked off and the pin may be lost, causing loss of flotation.

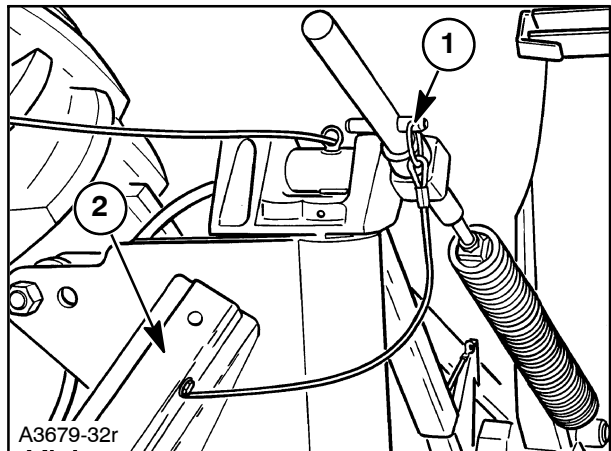

26



## LOWERING THE CUTTER BAR FOR FIELD OPERATION

**NOTICE:** Be sure the flotation pin, 1, is installed in the spring rod.

**NOTICE:** Be sure the limit chains are attached and adjusted as explained earlier.

1. Put tension on the transport latch release rope, 2. Raise or lower the lift cylinder with the tractor hydraulics until the latch can be released.

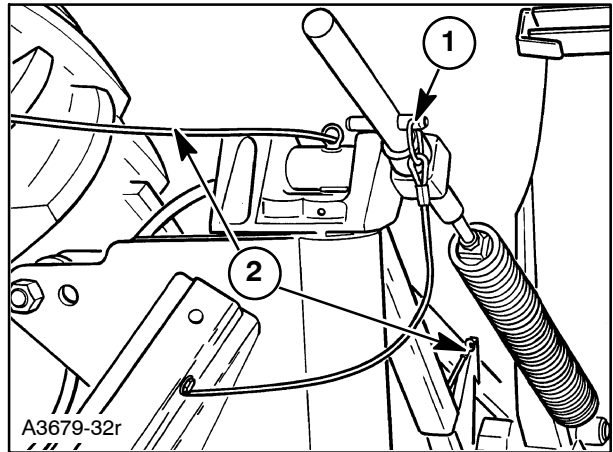

27

2. Lower the mower into the operating position and position the tractor valve in the float position. This will allow the mower to follow the ground properly. Be sure the up-stop channel, 2, is positioned over the lift cylinder rod to limit lift height while the curtain is down.
3. Unhook the curtain transport tie-down strap, 1, and fold the curtain forward into the mowing position.

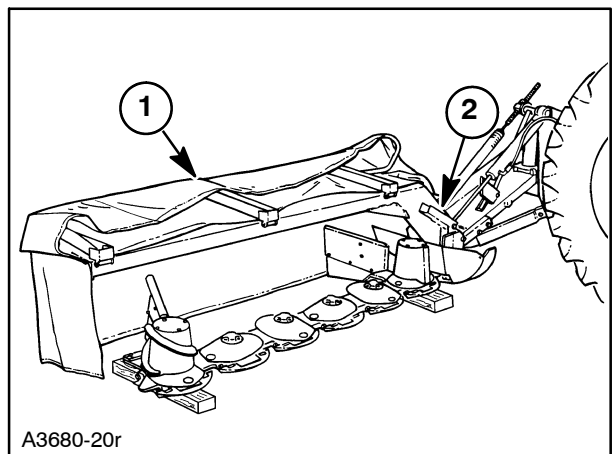

28

### ⚠ WARNING ⚠

**Never operate the mower with the curtain folded rearward in the transport position. Failure to comply could result in death or serious injury.**

M1210

### TRANSPORTING THE MOWER

1. Fold the front half of the cutter bar curtain, 1, rearward. Secure the curtain with the rubber tie strap, 2. Flip the cutter bar up-stop channel, 3, toward the cutter bar and against the brace.

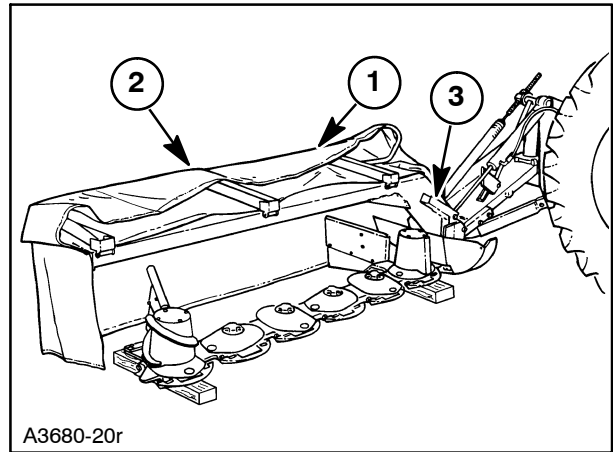

29

2. Raise the cutter bar with the tractor hydraulics. Raise it high enough to engage the transport latch, 1.

**NOTICE:** Before raising the cutter bar with the hydraulic cylinder, make sure there is adequate clearance between the machine and the tractor. The top link may have to be lengthened for the cutter bar to clear the cab.

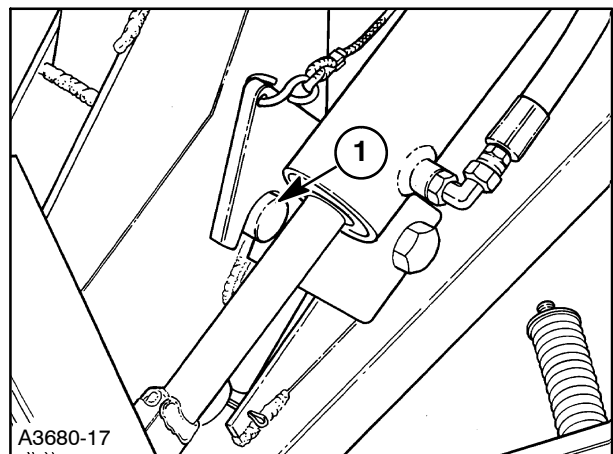

30

### REMOVING THE MOWER FROM THE TRACTOR

1. Fold the front half of the cutter bar curtain, 1, rearward. Secure the curtain with the rubber tie strap, 2. Flip the cutter bar up-stop channel, 3, toward the cutter bar and against the brace.

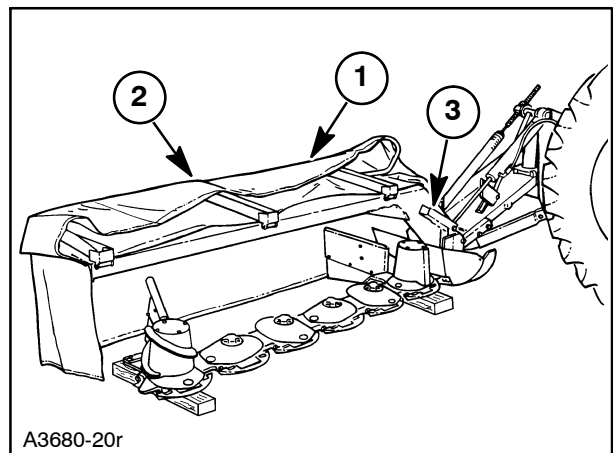

31

2. Raise the cutter bar with the tractor hydraulics. Raise it high enough to engage the transport latch, 1.

**NOTICE:** Before raising the cutter bar with the hydraulic cylinder, make sure there is adequate clearance between the machine and the tractor. The top link may have to be lengthened for the cutter bar to clear the cab.

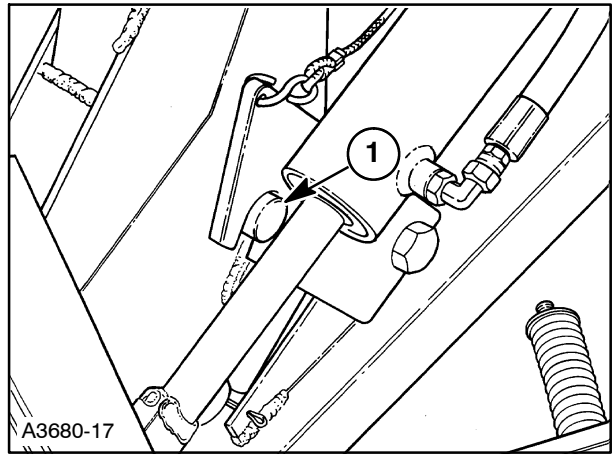

32

3. Remove the flotation spring pin, 1, from the spring rod.

**⚠ WARNING ⚠**

Disconnect the flotation system before attempting to remove the implement from the tractor. Failure to disconnect the flotation system could result in sudden movement, causing bodily injury. Failure to comply could result in death or serious injury.

M1496

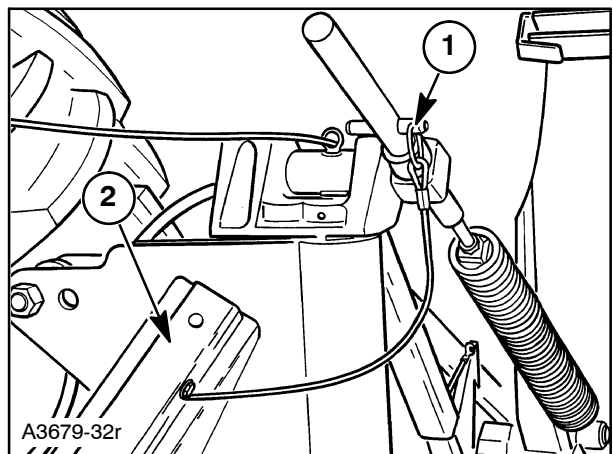

33

4. Remove the jack stand, 2, from the storage position.
5. Raise the tractor three-point hitch high enough to install the jack, 1, in the lift frame mount and install the pin, 2, to secure it.
6. Disconnect the limit chains, 3, from the rear of the tractor.
7. Lower the cutter bar to the ground in the mowing position and lower the tractor three-point hitch so the mower frame is sitting on the jack as shown.
8. Loosen, unlock, or remove the tractor sway bars or equivalent.
9. Disconnect the three-point hitch arms from the lift links, 4, and top link, 5, from the mower.
10. Disconnect the hydraulic hose, transport latch rope, and PTO from the tractor.

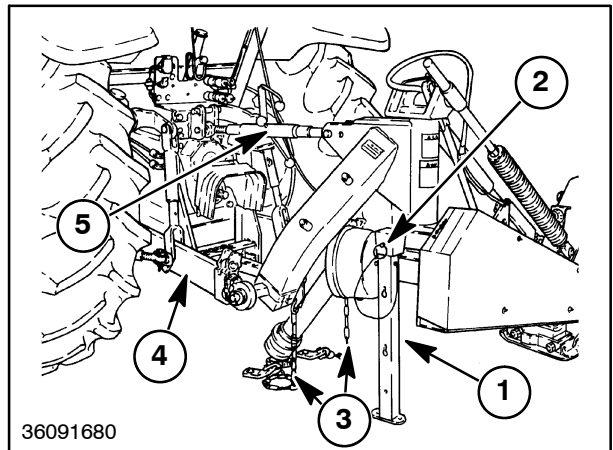

34

Thank you so much for reading.  
Please click the “Buy Now!”  
button below to download the  
complete manual.



After you pay.

You can download the most  
perfect and complete manual in  
the world immediately.

Our support email:

[ebooklibonline@outlook.com](mailto:ebooklibonline@outlook.com)