

Please Cut where indicated and place the label on the spine of the binder.

**5088, 6088,
7088 COMBINE**

Service Manual

84242798

Replaces 87719025

**5088, 6088,
7088 COMBINE**

Service Manual

84242798

Replaces 87719025

**5088, 6088,
7088 COMBINE**

Service Manual

84242798

Replaces 87719025

**5088, 6088,
7088 COMBINE**

Service Manual

84242798

Replaces 87719025

AXIAL-FLOW® 5088, 6088 AND 7088 COMBINE MASTER TABLE OF CONTENTS

NOTE: Engine repair information is not contained within this Service Manual. Refer to the Service Manuals for the 8.3 9L 6-Cylinder 24 Valve CNH Engine (5088 and 6088 Combines) and 9.0L Engine (7088 Combine).

BOOK 1 - 87719028

ELECTRICAL SCHEMATIC POSTER - PRIOR TO PIN Y8G000101.....87719035

ELECTRICAL SCHEMATIC POSTER - PIN Y8G000101 AND AFTER.....87474621

HYDRAULIC SCHEMATIC POSTER - PRIOR TO PIN Y8G00010187719034

HYDRAULIC SCHEMATIC POSTER - PIN Y8G000101 AND AFTER87474623

STANDARD TORQUE SPECIFICATIONSSECTION 1001

 TORQUE SPECIFICATIONS - DECIMAL HARDWARE 1001-2

 TORQUE SPECIFICATIONS - METRIC HARDWARE 1001-3

 TORQUE SPECIFICATIONS - STEEL HYDRAULIC FITTINGS 1001-4

 LOCTITE CHART 1001-5

STATIONARY AIR SCREEN.....SECTION 2004

 Nozzle Drive Motor 2004-3

 Removal 2004-3

 Installation 2004-5

 Vacuum Fan and Rotating Arm 2004-7

 Removal 2004-7

 Installation 2004- 0

ENGINE REMOVALSECTION 2020

 SPECIFICATIONS2020-2

 SPECIAL TORQUES2020-2

 SPECIAL TOOLS2020-2

 ENGINE REMOVAL 2020-3

 ENGINE INSTALLATION 2020-17

ELECTRICAL SCHEMATICS.....SECTION 4001

 SCHEMATIC COLOR LEGEND 4001-2

 SUBSYSTEM INDEX 4001-4

 ACTUATORS 4001-6

 POWER DISTRIBUTION 4001-8

 STARTING AND CHARGING SYSTEM 4001-9

 CHASSIS GROUNDS 4001-10

 CHASSIS GROUNDING POINT LOCATIONS 4001-11

 CLEAN GROUNDS 4001-12

 POWER DISTRIBUTION (FUSE BLOCKS) 4001-13

 UNLOADER CONTROL 4001-16

 GRAIN TANK COVERS CONTROL 4001-17

 CHAFFER SPREADER CONTROL 4001-18

 BACKUP ALARM.....4001-19

 FEEDER AND SEPARATOR CONTROL 4001-20

 SPREADER PATTERN CONTROL 4001-22

 HEADER SELECTOR VALVE/DECK PLATE CONTROL 4001-23

 CONCAVE CONTROL WITH PRESET MACHINES 4001-24

 FAN CONTROL WITH PRESET MACHINES 4001-26

 ROTOR CONTROL WITH PRESET MACHINES 4001-28

AXIAL-FLOW® 5088, 6088 AND 7088 COMBINE MASTER TABLE OF CONTENTS

SIEVE CONTROL	4001-30
MULTIFUNCTION PROPULSION HANDLE	4001-34
SIDE KNIVES (CAB).....	4001-35
HEADER REEL CONTROL	4001-36
HEADER HEIGHT/TILT CONTROL CAB	4001-38
HEADER HEIGHT/TILT CONTROL CHASSIS.....	4001-40
SPEED MONITOR	4001-44
A-POST INSTRUMENTATION	4001-46
GRAIN SCAN MONITOR	4001-48
RADIO	4001-49
WIPERS.....	4001-49
AUXILIARY POWER / HORN / DOME LIGHTS	4001-50
POWER GUIDE AXLE / VARIABLE PROPULSION	4001-51
LUBE SYSTEM	4001-52
RIDE CONTROL.....	4001-52
ENGINE AND THROTTLE CONTROL/GRID HEATER	4001-53
ENGINE CONTROL.....	4001-54
HVAC / CAB PRESSURE / AIR SEAT	4001-56
AUTO GUIDANCE	4001-58
PRECISION FARMING	4001-61
BACKLIGHTING / POWER	4001-62
BACKLIGHTING / GROUNDS	4001-63
SIEVE LIGHT & UNDERPANEL LIGHT	4001-64
TURN SIGNALS, TAIL/POSITION, AND BRAKE LIGHTS	4001-66
PARKING BRAKE CONTROL	4001-71
BEACON LIGHTS	4001-72
EUROPEAN HEADLIGHTS/BEACON LIGHTS	4001-73
FRONT ROOF WORK LIGHTS	4001-74
REAR, SIDE AND HEADER WORK LIGHTS	4001-76
CAN BUS AND RS232 SYSTEM	4001-78
ELECTRICAL SYSTEM.....	SECTION 4003
SPECIAL TOOLS	4003-3
INSTRUMENTATION AND CONTROLS	4003-4
FUSE AND RELAY IDENTIFICATION	4003-8
CAB CONNECTOR AND COMPONENT LOCATIONS	4003-12
GRAIN MOISTURE/BYPASS UNIT CONNECTOR LOCATIONS	4003-20
ROTOR SPEED CONTROL CONNECTOR LOCATIONS	4003-21
ENGINE COMPARTMENT CONNECTOR LOCATIONS	4003-22
BRAKE SWITCH CONNECTOR LOCATIONS	4003-24
MACHINE GROUND LOCATIONS	4003-25
GROUND POINT LOCATIONS	4003-26
COMBINE SENSOR LOCATIONS	4003-33
COMBINE SENSOR TESTING	4003-44
ELECTRICAL CONNECTORS PINOUT INFORMATION	4003-51
CAN TERMINATOR LOCATIONS	4003-93
STARTING SYSTEM CHECKLIST	4003-95
STARTING SYSTEM POWER DISTRIBUTION	4003-95
STARTER SYSTEM TROUBLESHOOTING	4003-96

BOOK 2 - 87719029

STEERING CYLINDER	SECTION 5030
SPECIAL TORQUES	5030-2
STEERING CYLINDER	5030-3
Removal	5030-3
Installation	5030-5
STEERING AXLE	SECTION 5040
Wheel Bearings	5040-3
Disassembly	5040-3
Assembly	5040-5
Servicing the Steering Tie Rod End	5040-6
Removal	5040-6
Installation	5040-8
Toe in Adjustment	5040-9
Steering Axle Assembly	5040-11
Axle Extension Positions	5040-12
Height Positions	5040-12
Width Positions	5040-13
Center Section	5040-14
Removal	5040-14
Installation	5040-18
Steering Knuckle	5040-22
Disassembly	5040-23
Assembly	5040-23
Bushing Replacement	5040-24
Removal	5040-24
Installation	5040-25
POWER GUIDE AXLE	SECTION 5054
Motor Removal	5054-3
Power Guide Axle - Exploded View	5054-4
Motor Installation	5054-5
HYDROSTATIC DRIVE PUMP	SECTION 6017
Removal	6017-3
Inspection	6017-7
Installation	6017-7
PROPULSION SYSTEM AIR REMOVAL	6017-11
Combines without Power Guide Wheels	6017-11
Combines with Power Guide Wheels	6017-12
HYDROSTATIC MOTOR	SECTION 6035
Removal	6035-3
Illustration of One Speed and Two Speed Hydrostatic Motors	6035-4
Installation	6035-5
TRANSMISSION REMOVAL AND INSTALLATION	6035-7
ILLUSTRATION OF TRANSMISSION REMOVAL	6035-9
Installation	6035-10
GEAR SHIFT CONTROL CABLE ADJUSTMENT	6035-12
PROPULSION SYSTEM AIR REMOVAL	6035-13
Combines without Power Guide Wheels	6035-13
Combines with Power Guide Wheels	6035-14

AXIAL-FLOW® 5088, 6088 AND 7088 COMBINE MASTER TABLE OF CONTENTS

BRAKE ASSEMBLY AND TRANSMISSION COVER REMOVAL.....	SECTION 6040
SPECIFICATIONS	6040-3
SPECIAL TORQUES	6040-3
SPECIAL TOOLS	6040-3
BRAKE ASSEMBLY AND TRANSMISSION COVER REMOVAL	6040-5
SHIFTER RAILS AND SHIFT FORK REMOVAL	6040-7
INPUT HOUSING AND SHAFT REMOVAL	6040-10
CHANGE GEAR SHAFT REMOVAL AND DISASSEMBLY	6040-13
DIFFERENTIAL REMOVAL AND DISASSEMBLY	6040-16
DIFFERENTIAL PINION SHAFT REMOVAL AND DISASSEMBLY	6040-21
DIFFERENTIAL PINION SHAFT ASSEMBLY AND INSTALLATION	6040-27
Setting The Differential Pinion Shaft End Play	6040-34
DIFFERENTIAL ASSEMBLY AND INSTALLATION	6040-36
Measuring the Shim Thickness for Differential Bearing Cap	6040-40
CHANGE GEAR SHAFT ASSEMBLY	6040-43
INPUT HOUSING AND SHAFT ASSEMBLY	6040-45
CHANGE GEAR SHAFT AND INPUT HOUSING INSTALLATION	6040-47
Setting the Change Gear Shaft End Play	6040-49
Measuring the Internal Spline Shaft Wear	6040-51
SHIFTER RAILS AND SHIFT FORK ASSEMBLY	6040-53
TRANSMISSION COVER AND BRAKE INSTALLATION	6040-57
CROSS-SECTIONAL DRAWING OF TRANSMISSION	6040-60
FINAL DRIVE SERVICE.....	SECTION 6060
SPECIFICATIONS	6060-2
SPECIAL TOOLS	6060-2
FINAL DRIVE SERVICE	6060-3
CROSS-SECTIONAL DRAWING OF FINAL DRIVE	6060-23
PTO GEARBOX	SECTION 6065
Section 6065 is in Book 4 of this Service Manual. It was issued with the first revision of this manual.	
PTO HOUSING SERVICE.....	SECTION 6071
SPECIFICATIONS	6071-2
SPECIAL TORQUES	6071-2
SPECIAL TOOLS	6071-2
PTO HOUSING SERVICE	6071-3
PTO Input Shaft Disassembly	6071-3
Separator Shaft Disassembly	6071-5
PTO Input Shaft Assembly	6071-5
Separator Shaft Assembly	6071-6
Shimming the Bevel Pinion Gear	6071-7
Separator Housing Installation and Bevel Gear Setting	6071-10
Bevel Gear Pattern Check	6071-11
BRAKE ASSEMBLIES SERVICE.....	SECTION 7010
SPECIFICATIONS	7010-2
BRAKE ASSEMBLIES SERVICE	7010-3
Disassembly	7010-3
Inspection	7010-8
Assembly	7010-10

BOOK 3 - 87719030

HYDRAULIC SYSTEM - HOW IT WORKS	SECTION 8001
GENERAL INTRODUCTION	8001-3
BASIC PRINCIPLES OF THE HYDRAULIC SYSTEM	8001-3
LOAD SENSE SIGNAL TO PFC PUMP COMPENSATOR	8001-4
HYDRAULIC SYSTEM COMPONENT LOCATION	8001-5
HYDRAULIC SYSTEM RESERVOIR	8001-6
HYDRAULIC SYSTEM PRESSURE SCREEN	8001-7
HYDRAULIC SYSTEM FILTRATION	8001-8
PISTON PUMP AND COMPENSATOR VALVE	8001-9
PFC PUMP SYSTEM SCHEMATIC	8001-10
PFC PUMP SYSTEM	8001-14
PFC PUMP EXPLODED VIEW	8001-15
AUXILIARY PUMP SYSTEM	8001-16
FEEDER DRIVE HYDRAULICS	8001-22
CHAFF SPREADER (OPTIONAL)	8001-24
CHAFF SPREADER HYDRAULICS	8001-25
MAIN VALVE COMPONENT LOCATIONS	8001-26
STATIONARY AIR SCREEN (SAS) SYSTEM	8001-31
STATIONARY AIR SCREEN (SAS) HYDRAULIC SYSTEM	8001-32
FEEDER REVERSER SYSTEM	8001-34
FEEDER REVERSER HYDRAULICS	8001-35
STEERING SYSTEM	8001-36
HYDRAULIC SYSTEM COMPONENT LOCATION	8001-37
STEERING RELIEF SETTING AND ADJUSTMENT	8001-40
HIGH PRESSURE STANDBY CHECK AND ADJUSTMENT	8001-41
LOW PRESSURE STANDBY CHECK AND ADJUSTMENT	8001-42
PRESSURE REGULATOR VALVE PRESSURE CHECK (400 PSI)	8001-43
REGULATED PRESSURE CHECK (290 to 320 PSI) AND ADJUSTMENT	8001-44
REEL DRIVE RELIEF PRESSURE CHECK AND ADJUSTMENT	8001-45
PRESSURE REGULATOR VALVE.....	SECTION 8015
Removal	8015-3
Disassembly and Inspection	8015-4
Assembly	8015-5
REMOVING AIR FROM THE HYDRAULIC SYSTEM	8015-6
AIR-CONDITIONING TROUBLESHOOTING.....	SECTION 9010
SAFETY PROCEDURES	9010-4
SPECIAL TOOLS	9010-5
ACCESSING THE EVAPORATOR/HEATER ASSEMBLY	9010-6
THEORY OF OPERATION	9010-7
Serviceable Components - Automatic Temperature Control (ATC)	9010-7
ATC Systems	9010-9
Temperature Range	9010-9
Smart Pressure Switch Cycling System	9010-10
A/C OPERATION	9010-10
ATC WIRING SCHEMATIC	9010-12
ATC TROUBLESHOOTING	9010-13
ATC Electrical Troubleshooting	9010-13

AXIAL-FLOW® 5088, 6088 AND 7088 COMBINE MASTER TABLE OF CONTENTS

ATC Fault Codes	9010-17
1 - High Pressure Switch and Circuit Test	9010-20
2 - Low Pressure Switch and Circuit Test	9010-20
3 - Blower Potentiometer and Circuit Test	9010-22
4 - Temperature Potentiometer and Circuit Test	9010-23
5 - Cab Temperature Sensor and Circuit Test	9010-24
6 - Evaporator Temperature Sensor and Circuit Test	9010-24
7 - ATC Controller Power Supply and Ground Test	9010-25
8 - Blower Motor Power Supply and Ground Test	9010-26
9 - Clutch Relay Power Supply and Ground Test	9010-27
10 - Heater Control Valve Power Supply and Ground Test	9010-27
11 - ATC Switch and Circuit Test	9010-28
12 - PWM Module Power Supply and Circuit Test	9010-28
13 - LCD Display and Circuit Test	9010-29
14 - Cab Pressurizer Blower Motor and Circuit Test	9010-29
EXTERNAL COMPRESSOR CHECK	9010-30
Compressor and Fan Belts	9010-30
Compressor Mounting Brackets	9010-30
Compressor Clutch	9010-31
Pulley and Belt Alignment	9010-32
OPERATIONAL MODES	9010-33
Keyed Power - Automatic Mode	9010-33
Defog/Defrost Mode	9010-34
BLOWER AND TEMPERATURE CONTROL	9010-35
Blower Motor	9010-35
Blower Speed Control - Temperature Control - ATC Switch - LCD Display	9010-35
Controller Initialization	9010-36
Blower Motor	9010-37
ATC Switch	9010-37
ATC CONTROLLER	9010-38
ATC Controller	9010-38
Low and High Pressure Switches	9010-39
Compressor Clutch	9010-40
CAB TEMPERATURE CHECK	9010-41
Air Louvers	9010-41
Air Conditioner Hose Check	9010-41
Lower Louver Temperature	9010-42
Compressor Hoses	9010-43
Leak Finding Check	9010-43
Heater Hoses	9010-43
Heater Control Valve	9010-44
EVAPORATOR AND PLENUM CHECK	9010-45
Evaporator Core	9010-45
Plenum Sealing	9010-45
Filters	9010-45
CAB AND EVAPORATOR TEMPERATURE SENSORS	9010-46
CAB PRESSURIZER BLOWER	9010-47
ATC COMPONENT LOCATIONS	9010-48

AXIAL-FLOW® 5088, 6088 AND 7088 COMBINE MASTER TABLE OF CONTENTS

HVAC SYSTEM SERVICE	SECTION 9020
SPECIFICATIONS	9020-2
SPECIAL TORQUES	9020-2
SPECIAL TOOLS	9020-3
SAFETY PROCEDURES	9020-4
AIR CONDITIONER SYSTEM REFRIGERANT RECOVERY	9020-5
A/C Compressor	9020-9
Oil Level Check or Adjustment	9020-9
Injection Method	9020-9
Dipstick Method	9020-10
Removal	9020-13
Installation	9020-15
Compressor Belt Adjustment	9020-17
AIR CONDITIONER SYSTEM EVACUATION AND RECHARGING	9020-18
AXIAL FLOW AIR CONDITIONING TEMPERATURE/PRESSURE CHART	9020-22
COMPRESSOR CLUTCH	9020-23
Removal	9020-23
Assembly	9020-27
THERMAL EXPANSION VALVE TESTING	9020-33
THERMAL EXPANSION VALVE REPLACEMENT	9020-35
ATC COMPONENTS	9020-38
CONDENSER, RECEIVER-DRIER AND TUBES	9020-40
INSTALLATION OF EVAPORATOR TEMPERATURE SENSOR	9020-41
HEATER AND EVAPORATOR CORE	9020-42
Accessing the A/C Unit	9020-42
Heater And Evaporator Core Removal	9020-43
Heater and Evaporator Core Installation	9020-47
AUTOMATIC TEMPERATURE CONTROL MODULE REPLACEMENT	9020-53
CAB RECIRCULATION AIR FILTER SERVICE	9020-54
CAB AIR INTAKE FILTER SERVICE	9020-54
CAB PRESSURIZATION TEST	9020-55
THREE SPEED ROTOR GEARBOX (Detent in Cover)	SECTION 9102
Section 9102 is in Book 4 of this Service Manual. It was issued with the first revision of this manual.	
THREE SPEED ROTOR GEARBOX (Detent in Housing).....	SECTION 9103
Section 9103 is in Book 4 of this Service Manual. It was issued with the first revision of this manual.	
FEEDER HOUSING AND ROTOR REMOVAL	SECTION 9104
SPECIFICATIONS	9104-2
SPECIAL TORQUES	9104-2
SPECIAL TOOLS	9104-2
FEEDER HOUSING	9104-3
Removal	9104-3
Installation	9104-10
ROTOR	9104-17
Removal	9104-17
Inspection And Repair	9104-23
Installation	9104-23
REPLACING THE ROTOR FRONT BEARING	9104-28
WITHOUT REMOVING THE ROTOR	9104-28
Rotor Impeller Blade Clearance Check	9104-36
FEEDER AND CLEANING FAN GEARBOX	SECTION 9106
SPECIFICATIONS	9106-2
SPECIAL TORQUES	9106-2
FEEDER AND CLEANING FAN GEARBOX	9106-3

AXIAL-FLOW® 5088, 6088 AND 7088 COMBINE MASTER TABLE OF CONTENTS

ELEVATOR DRIVE JACKSHAFT	SECTION 9109
SPECIAL TORQUES	9109-2
SPECIFICATIONS	9109-2
ELEVATOR DRIVE JACKSHAFT REMOVAL	9109-3
SERVICING THE ELEVATOR DRIVE JACKSHAFT	9109-4
Disassembly	9109-4
Assembly	9109-14
ELEVATOR DRIVE JACKSHAFT INSTALLATION	9109-23
POWER GRAIN BIN DOORS	SECTION 9118
Replacement of Actuator when able to power open covers	9118-3
Adjustments	9118-7
Replacement of Actuator when NOT able to power open covers	9118-8
STRAW CHOPPER GEARBOX	SECTION 9125
SPECIAL TORQUES	9125-2
SPECIFICATIONS	9125-2
STRAW CHOPPER GEARBOX	9125-3
Removal	9125-3
Disassembly	9125-4
Assembly	9125-14
Cross-Sectional Drawing of Straw Chopper Gearbox	9125-22
Installation	9125-23

BOOK 4 - 84242802

PTO GEARBOX	SECTION 6065
GENERAL SAFETY INFORMATION	6065-3
Removal	6065-4
Installation	6065-7
THREE-SPEED ROTOR GEARBOX (with Detent in Gearcase Cover)	SECTION 9102
GEARBOX REMOVAL PROCEDURE	9102-3
GEARBOX DISASSEMBLY	9102-8
GEARBOX ASSEMBLY	9102-26
GEARBOX INSTALLATION PROCEDURE	9102-33
THREE-SPEED ROTOR GEARBOX (with Detent in Gearcase Housing)	SECTION 9103
GEARBOX REMOVAL PROCEDURE	9103-3
GEARBOX DISASSEMBLY	9103-8
GEARBOX ASSEMBLY	9103-26
GEARBOX INSTALLATION PROCEDURE	9103-33
SHAKER SYSTEM ALIGNMENT	SECTION 9135
GENERAL INFORMATION	9135-3
GENERAL SAFETY INFORMATION	9135-3
SPECIAL TOOLS, LOCTITE® AND CLEANING SOLVENT	9135-4
ALIGNMENT PROCEDURE	9135-5

Section 1001

STANDARD TORQUE SPECIFICATIONS AND LOCTITE CHART

TABLE OF CONTENTS

TORQUE SPECIFICATIONS - DECIMAL HARDWARE 2

TORQUE SPECIFICATIONS - METRIC HARDWARE 3

TORQUE SPECIFICATIONS - STEEL HYDRAULIC FITTINGS 4

TORQUE SPECIFICATIONS - STEEL HYDRAULIC FITTINGS 5

TORQUE SPECIFICATIONS - DECIMAL HARDWARE

Use the torques in this chart when special torques are not given. These torques apply to fasteners with both UNC and UNF threads as received from suppliers dry, or when lubricated with engine oil. Not applicable if special graphities, Molydisulfide greases, or other extreme pressure lubricants are used.

Grade 5 Bolts, Nuts, and Studs		
		
Size	Pound-Inches	Newton metres
1/4 inch	108 to 132	12 to 15
5/16 inch	204 to 252	23 to 28
3/8 inch	420 to 504	48 to 57
Size	Pound-Feet	Newton metres
7/16 inch	54 to 64	73 to 87
1/2 inch	80 to 96	109 to 130
9/16 inch	110 to 132	149 to 179
5/8 inch	150 to 180	203 to 244
3/4 inch	270 to 324	366 to 439
7/8 inch	400 to 480	542 to 651
1.0 inch	580 to 696	787 to 944
1-1/8 inch	800 to 880	1085 to 1193
1-1/4 inch	1120 to 1240	1519 to 1681
1-3/8 inch	1460 to 1680	1980 to 2278
1-1/2 inch	1940 to 2200	2631 to 2983

Grade 8 Bolts, Nuts, and Studs		
		
Size	Pound-Inches	Newton metres
1/4 inch	144 to 180	16 to 20
5/16 inch	288 to 348	33 to 39
3/8 inch	540 to 648	61 to 73
Size	Pound-Feet	Newton metres
7/16 inch	70 to 84	95 to 114
1/2 inch	110 to 132	149 to 179
9/16 inch	160 to 192	217 to 260
5/8 inch	220 to 264	298 to 358
3/4 inch	380 to 456	515 to 618
7/8 inch	600 to 720	814 to 976
1.0 inch	900 to 1080	1220 to 1465
1-1/8 inch	1280 to 1440	1736 to 1953
1-1/4 inch	1820 to 2000	2468 to 2712
1-3/8 inch	2380 to 2720	3227 to 3688
1-1/2 inch	3160 to 3560	4285 to 4827

NOTE: Use thick nuts with Grade 8 bolts.

TORQUE SPECIFICATIONS - METRIC HARDWARE

Use the following torques when specifications are not given.

These values apply to fasteners with coarse threads as received from supplier, plated or unplated, or when lubricated with engine oil. These values do not apply if graphite or Molydisulfide grease or oil is used.

Grade 8.8 Bolts, Nuts, and Studs		
		
Size	Pound-Inches	Newton metres
M4	24 to 36	3 to 4
M5	60 to 72	7 to 8
M6	96 to 108	11 to 12
M8	228 to 276	26 to 31
M10	456 to 540	52 to 61
Size	Pound-Feet	Newton metres
M12	66 to 79	90 to 107
M14	106 to 127	144 to 172
M16	160 to 200	217 to 271
M20	320 to 380	434 to 515
M24	500 to 600	675 to 815
M30	920 to 1100	1250 to 1500
M36	1600 to 1950	2175 to 2600

Grade 10.9 Bolts, Nuts, and Studs		
		
Size	Pound-Inches	Newton metres
M4	36 to 48	4 to 5
M5	84 to 96	9 to 11
M6	132 to 156	15 to 18
M8	324 to 384	37 to 43
Size	Pound-Feet	Newton metres
M10	54 to 64	73 to 87
M12	93 to 112	125 to 150
M14	149 to 179	200 to 245
M16	230 to 280	310 to 380
M20	450 to 540	610 to 730
M24	780 to 940	1050 to 1275
M30	1470 to 1770	2000 to 2400
M36	2580 to 3090	3500 to 4200

Grade 12.9 Bolts, Nuts, and Studs



Usually the torque values specified for grade 10.9 fasteners can be used satisfactorily on grade 12.9 fasteners.

TORQUE SPECIFICATIONS - STEEL HYDRAULIC FITTINGS

Tube OD Hose ID	Thread Size	Pound- Inches	Newton metres
37 Degree Flare Fitting			
1/4 inch 6.4 mm	7/16-20	72 to 144	8 to 16
5/16 inch 7.9 mm	1/2-20	96 to 192	11 to 22
3/8 inch 9.5 mm	9/16-18	120 to 300	14 to 34
1/2 inch 12.7 mm	3/4-16	180 to 504	20 to 57
5/8 inch 15.9 mm	7/8-14	300 to 696	34 to 79
Tube OD Hose ID	Thread Size	Pound- Foot	Newton metres
3/4 inch 19.0 mm	1-1/16-12	77 to 82	104 to 111
7/8 inch 22.2 mm	1-3/16-12	90 to 100	122 to 136
1.0 inch 25.4 mm	1-5/16-12	110 to 120	149 to 163
1-1/4 inch 31.8 mm	1-5/8-12	140 to 150	190 to 204
1-1/2 inch 38.1 mm	1-7/8-12	225 to 240	305 to 325

Tube OD Hose ID	Thread Size	Pound- Inches	Newton metres
Straight Threads with O-ring			
1/4 inch 6.4 mm	7/16-20	144 to 228	16 to 26
5/16 inch 7.9 mm	1/2-20	192 to 300	22 to 34
3/8 inch 9.5 mm	9/16-18	300 to 480	34 to 54
1/2 inch 12.7 mm	3/4-16	540 to 804	57 to 91
Tube OD Hose ID	Thread Size	Pound- Foot	Newton metres
5/8 inch 15.9 mm	7/8-14	58 to 92	79 to 124
3/4 inch 19.0 mm	1-1/16-12	80 to 128	108 to 174
7/8 inch 22.2 mm	1-3/16-12	100 to 160	136 to 216
1.0 inch 25.4 mm	1-5/16-12	117 to 187	159 to 253
1-1/4 inch 31.8 mm	1-5/8-12	165 to 264	224 to 357
1-1/2 inch 38.1 mm	1-7/8-12	250 to 400	339 to 542

Split Flange Mounting Bolts		
Size	Pound- Inches	Newton metres
5/16-18	180 to 240	20 to 27
3/8-16	240 to 300	27 to 34
7/16-14	420 to 540	47 to 61
Size	Pound- Feet	Newton metres
1/2-13	55 to 65	74 to 88
5/8-11	140 to 150	190 to 203

TORQUE SPECIFICATIONS - STEEL HYDRAULIC FITTINGS

Nom. SAE Dash Size	Tube OD	Thread Size	Pound-Inches	Newton metres	Thread Size	Pound-Inches	Newton metres
O-ring Face Seal End					O-ring Boss End Fitting or Lock Nut		
-4	1/4 inch 6.4 mm	9/16-18	120 to 144	14 to 16	7/16-20	204 to 240	23 to 27
-6	3/8 inch 9.5 mm	11/16-16	216 to 240	24 to 27	9/16-18	300 to 360	34 to 41
-8	1/2 inch 12.7 mm	13/16-16	384 to 480	43 to 54	3/4-16	540 to 600	61 to 68
					Thread Size	Pound-Foot	Newton metres
-10	5/8 inch 15.9 mm	1-14	552 to 672	62 to 76	7/8-14	35 to 40	47 to 54
Nom. SAE Dash Size	Tube OD	Thread Size	Pound-Foot	Newton metres	1-1/16-12	60 to 70	81 to 95
					1-3/16-12	70 to 80	95 to 109
-12	3/4 inch 19.0 mm	1-3/16-12	65 to 70	90 to 95	1-5/16-12	80 to 90	108 to 122
-14	7/8 inch 22.2 mm	1-3/16-12	65 to 70	90 to 95	1-5/8-12	95 to 115	129 to 156
-16	1.0 inch 25.4 mm	1-7/16-12	92 to 100	125 to 135	1-7/8-12	120 to 140	163 to 190
-20	1-1/4 inch 31.8 mm	1-11/16-12	125 to 140	170 to 190			
-24	1-1/2 inch 38.1 mm	2-12	150 to 165	200 to 225			

NOTE: CNH America LLC reserves the right to make improvements in design or changes in specifications at any time without incurring any obligation to install them on units previously sold.

Section 2004

STATIONARY AIR SCREEN

TABLE OF CONTENTS

STATIONARY AIR SCREEN (SAS)	2004 - 3
Nozzle Drive Motor	2004 - 3
Removal	2004 - 3
Installation	2004 - 5
Vacuum Fan and Rotating Arm	2004 - 7
Removal	2004 - 7
Installation	2004 - 10

STATIONARY AIR SCREEN (SAS)

Nozzle Drive Motor

Removal

STEP 1

Park the Combine on a flat level surface. Open the right rear body panel.

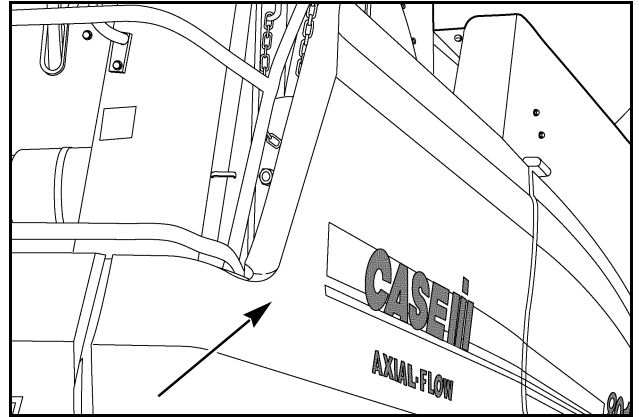

RH08B038

STEP 2

Mark the hoses for reference when reassembling. Remove the hoses from the fittings.

NOTE: *Plug and cap all disconnected hoses and fittings.*

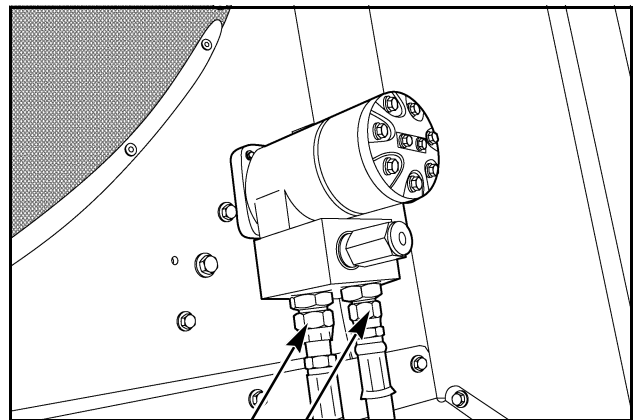

RH08B039

STEP 3

Open the stationary air screen (SAS) door for access to the mounting bolts.

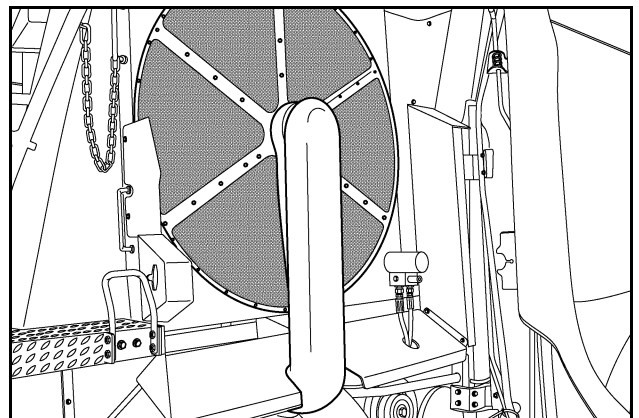

RH08B040

2004-4

STEP 4

Pry back the belt tensioner and remove the drive belt.

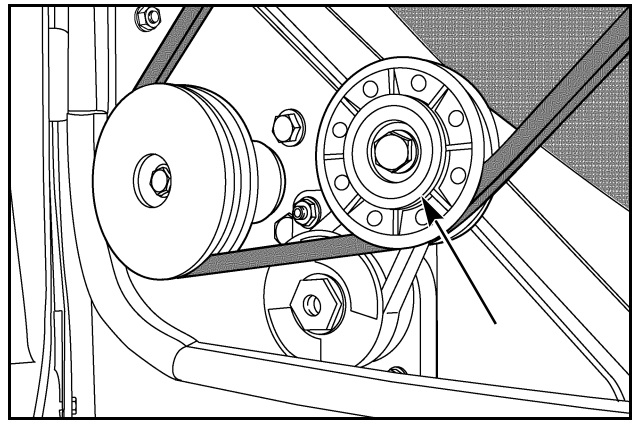

RH08B041

STEP 5

On the motor drive pulley remove the center bolt. Remove the pulley.

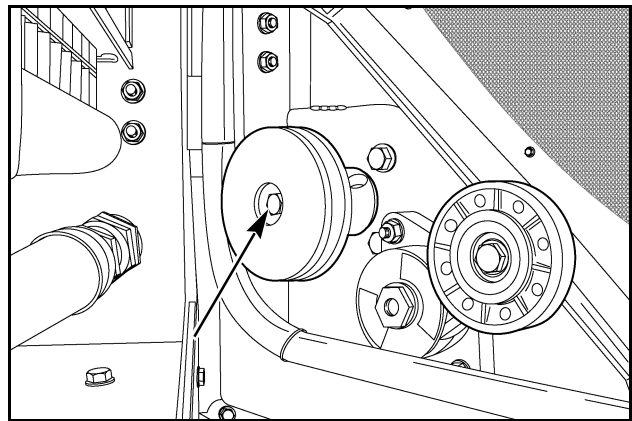

RH08B042

STEP 6

Support the nozzle motor and remove the four motor mounting bolts. Remove the nozzle motor from the machine.

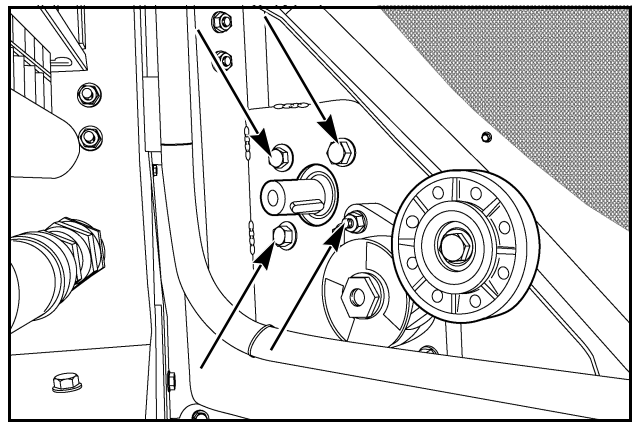

RH08B043

Installation

STEP 7

Install the nozzle motor to the machine. While supporting the nozzle motor, install the four motor mounting bolts.

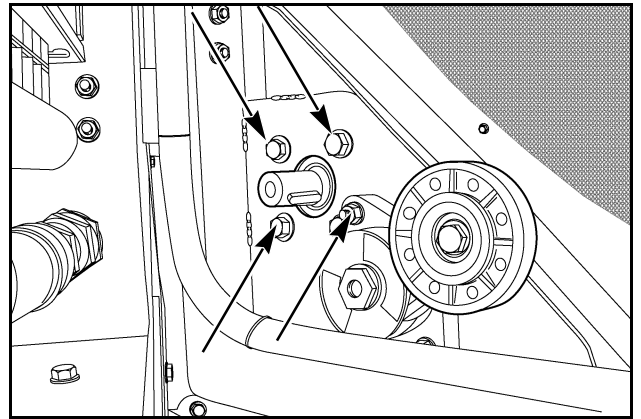

RH08B043

STEP 8

Make sure the key is installed in the keyway. Then install the motor drive pulley to the nozzle motor shaft. Secure with the center bolt.

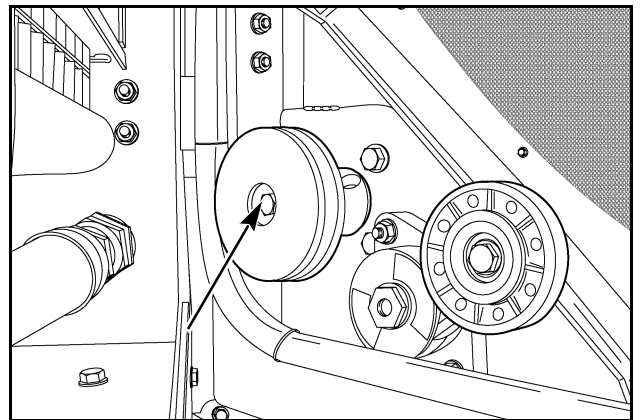

RH08B042

STEP 9

Pry back the belt tensioner and install the drive belt.

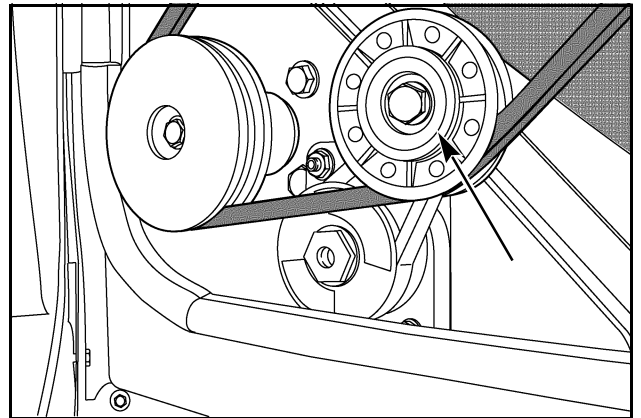

RH08B041

Thank you so much for reading.
Please click the “Buy Now!”
button below to download the
complete manual.



After you pay.

You can download the most
perfect and complete manual in
the world immediately.

Our support email:

ebooklibonline@outlook.com