



5000HD Air Drill

Repair Manual

REPAIR PARTS IDENTIFICATION

This implement has a Product Identification Number (PIN) plate. The plate looks like the sample at right. For easy reference, locate the PIN plate at the location shown on the figure below. Record the number on this sheet. When requiring repair parts, take this number into your dealer.

CNH Canada, Ltd. Toronto, ON M5X 1B8 Canada		
flexicoil		
Made In Canada		
○	Model Number	○
	Product Identification Number	

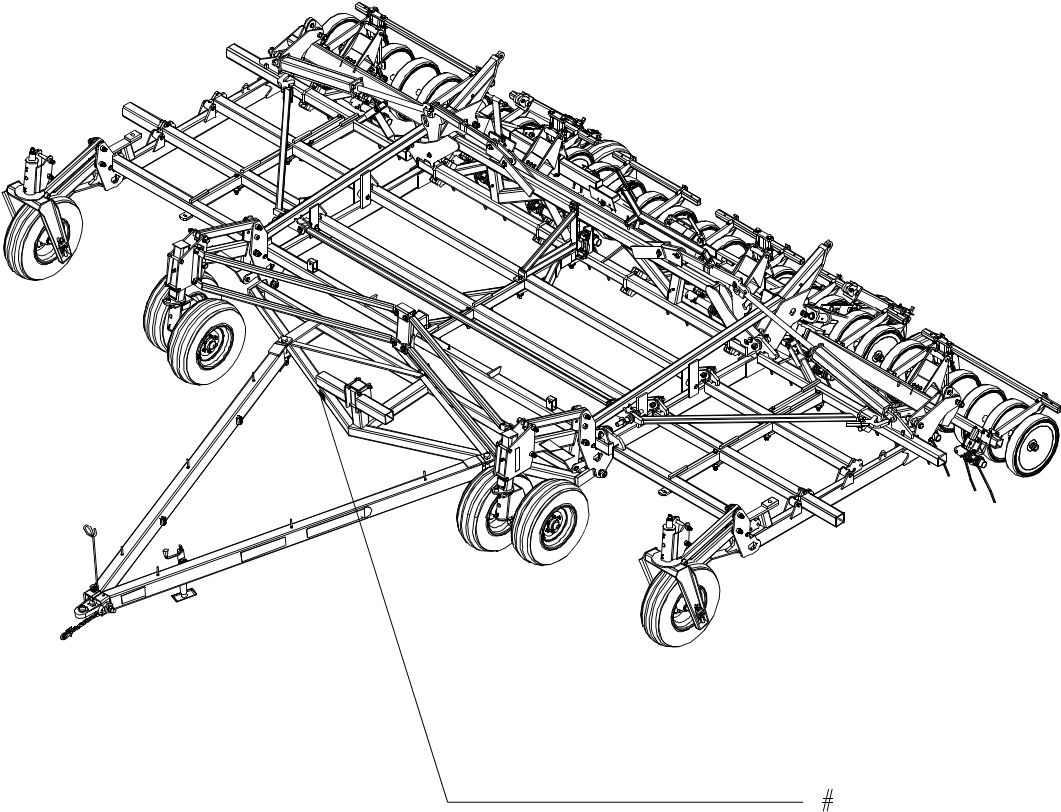

This Page is Left Blank

TABLE OF CONTENTS

Pages listed are a table of contents for that section

Section - Title	Page
1 - GENERAL INFORMATION	1-1
General Service Information	
Important Information	
Service Tools	
Safety	
Units of Measure	
Bolt Torque Information	
Machine Specifications	
Paint Touch-up Procedure	
2 - ADJUSTMENTS	2-1
Air Drill Leveling	
Floating Hoe/Shank Adjustments	
Sweep Pitch Adjustments	
Trip Torque Specifications	
Setting the Depth Gauge	
Wing Lead Adjustment	
3 - MECHANICAL SERVICE	3-1
Troubleshooting Tables	
Servicing Safety Precautions	
General Operating Information	
Grease Locations	
Maintenance	
Tires	
Caster Wheels	
Caster Hub and Spindle Maintenance	
Walking Beam Replacement	
Caster Transport Lock Installation	
Pin Guides	
Depth Control Service	
Walking Beam Carrier Spool Replacement	
Auxiliary Tow Hitch	
4 - HYDRAULICS	4-1
Hydraulics	
Replace Seals in Cylinders	
Hydraulic Cylinders	
Depth Control	
Wing Lift Hydraulics	
5 - ELECTRICAL	5-1
Connector Service Kit	
Remote Switch Installation	
6 - TRIPS, OPENERS, AND PRESS WHEEL SERVICE	6-1
Service of Openers	
Press Wheels and Shanks	
Ground Openers and Seed Boots	
Troubleshooting Tables	
Trip Compressor Tool Kit	
Tension Link Kit - 550 Pound Trip	
Adjustment of Trip Assemblies	
Trip/Shank Shim Installation	
Heavy Duty Bearing Kits	
Press Wheel Removal	
Packer Wheel Rest Assembly	
Shank Spacing and Trip Release Pressure	
Sweep Pitch Adjustment	
Trip Torque Specifications	
7 - AIR SYSTEM	7-1
Troubleshooting Tables	
Hoses	
Theory of Operation - Air System	
Determining Adequate Carrying Velocities	
Header Assemblies	
Hose Holder Brackets and Distribution Clamps	
8 - ENDMARKER SERVICE	8-1
Endmarkers	
Endmarker Replacement	
Endmarker Hydraulics	
Endmarker Operation and Adjustment	
INDEX	

This Page is Left Blank

SECTION 1

GENERAL INFORMATION

CONTENTS OF THIS SECTION

	Page
GENERAL SERVICE INFORMATION	1-3
IMPORTANT INFORMATION	1-4
SERVICE TOOLS	1-4
SAFETY	1-5
General Safety Practices	1-6
Servicing Safety Precautions	1-6
Safety During Operation	1-7
Air and Air Hoses	1-10
Hydraulics and Hydraulic Leaks	1-10
Shields	1-11
Electrical	1-11
Tires	1-11
Safety During Transport	1-12
Safety Decals	1-12
Decal Locations	1-13
Transport Lighting Assembly	1-14
UNITS OF MEASURE	1-16
Abbreviations	1-16
Conversion Chart	1-17
BOLT TORQUE INFORMATION	1-18
MACHINE SPECIFICATIONS	1-20
Air Drill Dimensions	1-20
Machine Composition	1-21
Implement Weight	1-21
Other Specifications	1-24
PAINT TOUCH-UP PROCEDURE	1-25

SECTION 1 - GENERAL INFORMATION

This Page is Left Blank

GENERAL SERVICE INFORMATION

NOTE: Read instructions carefully before you begin.

1. Be sure to read and follow all instructions to ensure proper assembly, operation, and service of the implement.
2. Service may require the use of a forklift or other suitable lifting device.
3. Implement must be serviced on a flat surface.
4. Left and right direction are determined from the rear of the implement facing the forward direction of travel.
5. Use a suitable sealant on hydraulic connections; sealant paste is recommended. Be careful to prevent sealant from entering the hydraulic system.
6. Apply a thread sealant to all female-to-male pipe thread connections.
7. Do not allow tape to enter the hydraulic system.
8. Do not use a thread sealant on ORB or swivel fitting connections.

NOTE: If you are assembling or servicing the implement inside of a building, ensure the door opening is large enough to allow the implement to be removed after assembly. Check the Specifications Tables in this section for the overall height and width in transport position.

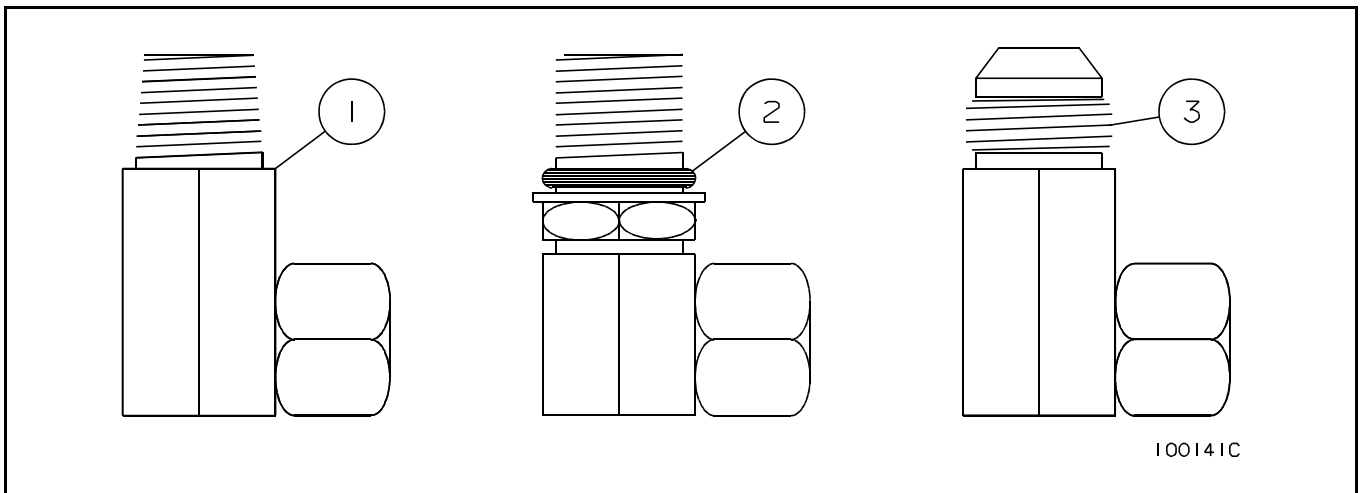

Hydraulic Fitting Identification

NOTE: Pipe thread fittings (1), O-ring boss fittings (2) and JIC fittings (3) may be the types of hydraulic fittings used.

SECTION 1 - GENERAL INFORMATION

IMPORTANT INFORMATION

All repair and maintenance work listed in this manual must be carried out only by qualified dealership personnel. Strictly comply with all instructions given. Use only the specialized tools required.

Anyone who carries out the above operations without complying with the procedures shall be responsible for the subsequent damages.

The manufacturer and all the organizations of its distribution chain, including (without limitation) national, regional, or local dealers, reject any responsibility for damages due to the anomalous behavior of parts and/or components not approved by the manufacturer itself. This includes those parts and/or components used for the servicing or repair of the product manufactured or marketed by the manufacturer.

In any case, no warranty is given or attributed on the product manufactured or marketed by the manufacturer in case of damages due to an anomalous behavior of parts and/or components not approved by the manufacturer.

The information in this manual is up to date at the date of the publication. It is the policy of the manufacturer to aim for continuous improvement. Some information could not be updated due to modifications of a technical or commercial type, as well as to suit the laws and regulations of different countries.

In case of disagreement, refer to your Sales and Service Networks.

SERVICE TOOLS

There are several service tools/update kits available through the parts department, for ease of servicing the air drill.

87446440	PIN GUIDES - (3) GUIDES FOR INSTALLING 1" AND 1.25" PINS
DS-200K	KIT, PRESS WHEEL PULLER - PULLING TOOL
DR-112K	KIT, TRANSPORT LOCK, SINGLE CASTER
DR-114K	KIT, TRANSPORT LOCK, DUAL CASTER
TP-950K	KIT, TRIP ASSEMBLY COMPRESSOR
87449833	WRENCH, ADJUSTING PACKER SET, CONTAINS DR-902 AND DR-903
DR-902	WRENCH, ADJUSTING PACKER LEFT
DR-903	WRENCH, ADJUSTING PACKER RIGHT

SAFETY

SAFETY - ALERT SYMBOL



This symbol is used to denote possible danger and care should be taken to prevent bodily injury. This symbol means **ATTENTION! BECOME ALERT! YOUR SAFETY IS INVOLVED!**

THIS SYMBOL APPEARS WITH TEXT READING “DANGER!”, “CAUTION!”, OR “WARNING!” THESE WORDS INDICATE THREE LEVELS OF POSSIBLE HAZARDS; THEY ARE DESCRIBED BELOW.

DANGER!



Indicates an imminently hazardous situation that, if not avoided, will result in death or serious injury. The color associated with Danger is RED.

WARNING!



Indicates a potentially hazardous situation that, if not avoided, could result in death or serious injury. The color associated with Warning is ORANGE.

CAUTION!



Indicates a potentially hazardous situation that, if not avoided, may result in minor or moderate injury. The color associated with Caution is YELLOW.

SECTION 1 - GENERAL INFORMATION

GENERAL SAFETY PRACTICES

REVIEW this manual and operator's manual before servicing equipment.

NEVER allow anyone unfamiliar, untrained, or complacent to operate the air drill.

ALWAYS USE the jack supplied when unhooking the air drill.

ALWAYS ensure weight of towing vehicle is heavier than implement.

NEVER transport the air drill at speeds higher than 25 km/hr (16 mph).

NEVER transport the air drill and air cart with product in tank.

MAINTAIN YOUR AIR DRILL in proper working condition. Unauthorized modifications to the machine may impair function and/or safety and affect machine life.

BE SURE the air drill is securely fastened to a large farm tractor or an air cart that is attached to a large farm tractor before operating hydraulics.

USE EXTREME CARE when making adjustments.

KEEP CHILDREN AWAY from all farm equipment.

SERVICING SAFETY PRECAUTIONS

BLOCK the wheels to prevent movement when servicing.

BE SURE the press wheels are blocked and wing lock pins are in place before servicing or adjusting opener assemblies or working on the air drill.

CAUTION!



The tractor engine should be stopped and the wheels blocked to prevent any movement during servicing.

Always be sure that the depth control safety lock is in place when servicing the air drill.

Always be sure the wings are in field position before servicing the air drill.

Escaping hydraulic fluid is a serious hazard. Escaping hydraulic fluid that is under pressure can penetrate the skin, causing serious injury. Relieve pressure before disconnecting the hydraulic lines.

Check/tighten all connections before applying pressure.

Never use your hand to search for leaks. Use a piece of cardboard or paper. If any fluid is injected into the skin, seek immediate medical attention. Gangrene may result if the wound is not treated within a few hours. Check your hydraulic fluid containers for warnings concerning the hydraulic fluids you use.

DO NOT walk within the radius of raised air drill wings.

Thank you so much for reading.
Please click the “Buy Now!”
button below to download the
complete manual.



After you pay.

You can download the most
perfect and complete manual in
the world immediately.

Our support email:

ebooklibonline@outlook.com