

Technician Service Book - MF 5700 Dyna-4 series tractors

MF 5708 Dyna-4

MF 5709 Dyna-4

MF 5710 Dyna-4

MF 5711 Dyna-4

Schémas électriques et hydrauliques

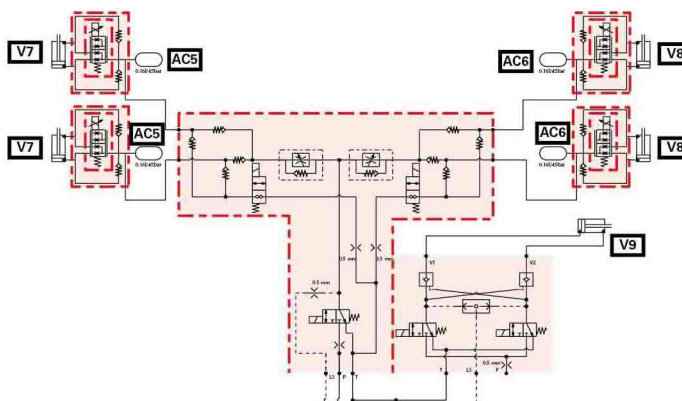
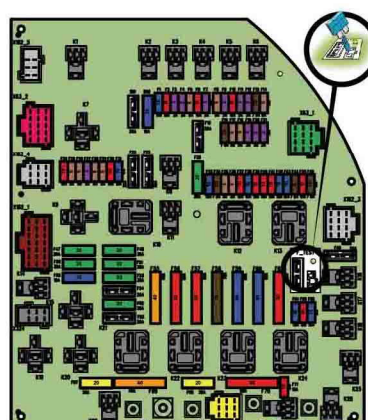

Technician Service Book - MF 5700 Dyna-4 series tractors

1 General Information	1-1
1.1 General specifications	1-3
1.1.1 MF 5708 Dyna-4 model	1-3
1.1.2 MF 5709 Dyna-4 model	1-4
1.1.3 MF 5710 Dyna-4 model	1-5
1.1.4 MF 5711 Dyna-4 model	1-6
1.2 Forward speeds	1-8
1.2.1 Forward speed at 2200 tr/min with GPA 52 gearbox and 16.9R38 tires	1-8
1.2.2 Forward speed at 2200 tr/min with GPA 54 gearbox and 16.9R38 tires	1-8
1.3 Dimensions and weights	1-10
1.3.1 Dimensions and weights	1-10
1.4 Attachment points	1-13
1.4.1 Attachment points for 3-cylinder engines	1-13
1.4.2 Attachment points for 4-cylinder engines	1-15
1.5 Capacities	1-17
1.5.1 capacities	1-17
1.6 Tightening torques, retaining compounds and sealing products	1-19
1.6.1 Retaining compounds and sealing products	1-19
1.6.2 Tightening torques for screws and nuts	1-20
1.6.3 Tightening torques for hydraulic unions	1-24
1.7 Units of measurement	1-28
1.7.1 Conversion table	1-28
2 Error codes	2-1
2.1 Error codes	2-3
2.1.1 General table of faults	2-3
2.1.2 Indicator light panel	2-5
2.1.3 Indication of faults	2-13
2.1.4 Description of error code format	2-14
2.1.5 Error codes	2-15
2.1.6 Engine error codes - AGCO Power	2-19
3 Fuse box	3-1
3.1 Fuse box	3-3
3.1.1 Description of the main fuse box	3-3
3.1.2 Description of the secondary fuse box	3-8
3.1.3 Description of additional fuses and relays	3-10
3.1.4 Battery isolator	3-13
4 Electrical diagrams	4-1
4.1 Electrical diagrams	4-3
4.1.1 Identification of electrical diagrams	4-3
4.1.2 Identification of electrical connectors from X1 to X500	4-5
4.1.3 Identification of electrical connectors from X501 to X1082	4-17
4.1.4 Identification of other electrical connectors	4-27
4.1.5 Identification table for cable colors	4-27
4.1.6 Electrical diagrams	4-29
4.1.6.1 Identification table for cable colors	4-29

4.1.6.2	EFD00100_22 - 4-wheel drive	4-29
4.1.6.3	EFD00101_22 - Differential lock	4-30
4.1.6.4	EFD00114_35 - Radio	4-31
4.1.6.5	EFD00117_44 - Additional heater	4-32
4.1.6.6	EFD00117_45 - Air conditioning	4-33
4.1.6.7	EFD00136_69 - Indicators and hazard warning lights	4-34
4.1.6.8	EFD00137_29 - Number plate lighting	4-35
4.1.6.9	EFD00138_48 - Side lights	4-36
4.1.6.10	EFD00140_62 - High beam lamps	4-37
4.1.6.11	EFD00148_16 - Horn	4-38
4.1.6.12	EFD00176_25 - Loader	4-39
5	Harnesses	5-1
5.1	Harnesses	5-3
5.1.1	Identification of harnesses	5-3
5.1.2	Identification table for cable colors	5-6
5.1.3	Harnesses	5-9
5.1.3.1	FAI200 - Engine harness 33 AWFC - ACW154879_1/1	5-9
5.1.3.2	FAI200 - Engine harness 44 AWFC - ACW220085_1/1	5-10
5.1.3.3	FAI201 - Front headlights harness - 4391617_1/1	5-11
5.1.3.4	FAI203 - Drive train harness_ACW146556_1/1	5-12
5.1.3.5	FAI210 - Cab drive train harness_ACW153845_1/1	5-13
5.1.3.6	FAI219 - Cab interior current socket harness - 4290574_1/2	5-14
5.1.3.7	FAI219 - Cab interior current socket harness - 4290574_2/2	5-15
5.1.3.8	FAI219 - Cab interior current socket harness_ACW075374_1/1	5-16
5.1.3.9	FAI253 - Hand rail harness_ACW083154_1/2	5-17
5.1.3.10	FAI253 - Hand rail harness_ACW083154_2/2	5-18
5.1.3.11	FAI253 - Hand rail harness_ACW113245_1/2	5-19
5.1.3.12	FAI253 - Hand rail harness_ACW113245_2/2	5-20
5.1.3.13	FAI253 - Hand rail harness_ACW163276_1/2	5-21
5.1.3.14	FAI253 - Hand rail harness_ACW163276_2/2	5-22
5.1.3.15	FAI253 - Hand rail harness_ACW163281_1/2	5-23
5.1.3.16	FAI253 - Hand rail harness_ACW163281_2/2	5-24
5.1.3.17	FAI275 - Trailer connector harness_ACW065138_1/2	5-25
5.1.3.18	FAI275 - Trailer connector harness_ACW065138_2/2	5-26
5.1.3.19	FAI280 - Negative battery harness_ACW005961_1/1	5-27
5.1.3.20	FAI310 - Battery/battery isolator negative cable harness_ACW004177_1/1	5-28
5.1.3.21	FAI316 - Roof harness_ACW016487_1/2	5-29
5.1.3.22	FAI316 - Roof harness_ACW016487_2/2	5-30
5.1.3.23	FAI340 - Battery/fuse box positive cable harness_ACW232117_1/2	5-31
5.1.3.24	FAI340 - Battery/fuse box positive cable harness_ACW232117_2/2	5-32
5.1.3.25	FAI379 - ABS trailer connector harness_ACW117041_1/1	5-33
5.1.3.26	FAI379 - ABS trailer connector harness_ACW141052_1/2	5-34
5.1.3.27	FAI379 - ABS trailer connector harness_ACW141052_2/2	5-35
6	Hydraulics diagrams	6-1
6.1	Hydraulics diagrams	6-3
6.1.1	Hydraulics diagrams	6-5
6.1.1.1	HFD01092 - Auxiliary hydraulics diagram: all options, Open Center, 57 L/min - 1/1	6-5
6.1.1.2	HFD01093 - Auxiliary hydraulics diagram: all options, Open Center, 98 L/min - 1/1	6-6
7	Pneumatic diagrams	7-1
7.1	Pneumatic diagrams	7-3
7.1.1	Pneumatic diagrams	7-5

7.1.1.1 PFD01026 - Trailer braking pneumatic diagram	7-5
8 Adjustments, bleeding and calibrations	8-1
8.1 Bleeding	8-3
8.1.1 Bleeding the trailer brake circuit	8-3
8.2 Calibrations	8-5
8.2.1 Access to instrument panel calibration screen	8-5
8.2.2 Dyna-4: PowerShuttle transmission calibration	8-6
8.2.3 Calibrating the rear linkage	8-9
8.2.4 Calibration of the rear linkage height/depth control	8-11
8.2.5 Calibration of the throttle pedal sensor	8-13
8.2.6 Calibration of the forward travel lever sensor	8-14
8.2.7 Calibrating the clutch pedal	8-16
8.2.8 Calibration error codes	8-18

1. General Information

1.1 General specifications	1-3
1.1.1 MF 5708 Dyna-4 model	1-3
1.1.2 MF 5709 Dyna-4 model	1-4
1.1.3 MF 5710 Dyna-4 model	1-5
1.1.4 MF 5711 Dyna-4 model	1-6
1.2 Forward speeds	1-8
1.2.1 Forward speed at 2200 tr/min with GPA 52 gearbox and 16.9R38 tires.	1-8
1.2.2 Forward speed at 2200 tr/min with GPA 54 gearbox and 16.9R38 tires.	1-8
1.3 Dimensions and weights	1-10
1.3.1 Dimensions and weights	1-10
1.4 Attachment points	1-13
1.4.1 Attachment points for 3-cylinder engines	1-13
1.4.2 Attachment points for 4-cylinder engines	1-15
1.5 Capacities	1-17
1.5.1 capacities	1-17
1.6 Tightening torques, retaining compounds and sealing products	1-19
1.6.1 Retaining compounds and sealing products	1-19
1.6.2 Tightening torques for screws and nuts	1-20
1.6.3 Tightening torques for hydraulic unions	1-24
1.7 Units of measurement	1-28
1.7.1 Conversion table	1-28

1.1 General specifications

1.1.1 MF 5708 Dyna-4 model

Engine	
Brand	AGCO Power
Type	Tier 4F/Stage IV SCR Technology engine
Model	33AWFC
Number of cylinders	3
Maximum ISO power (HP)	85
Maximum torque (Nm)	347

gearbox
GBA50 - 16X16 with 4 powershift ratios and shuttle Power Shuttle Control

Rear axle type
GPA50 - P144B

Final drive type
GPA52

Power take-off	
PTO type	Shiftable
Speeds	540/540E rpm - 540/1000 rpm - 540/540E/1000 rpm
Speed selector control	Electrohydraulic

Front axle	
Front axle type	4-wheel drive
Brand	CARRARO 20.16
Speed	40 km/h
Synchronization ratio (displayed on the name plate)	1.326

Hydraulics	
Hydraulic type	57 l or 98 l Open Center
Number of spool valves	0-1-2-3

Environment
Operator environment

1.1.2 MF 5709 Dyna-4 model

Engine	
Brand	AGCO Power
Type	Tier 4F/Stage IV SCR Technology engine
Model	33AWFC
Number of cylinders	3
Maximum ISO power (HP)	95
Maximum torque (Nm)	355

gearbox
GBA50 - 16X16 with 4 powershift ratios and shuttle Power Shuttle Control

Rear axle type
GPA50 - P144B

Final drive type
GPA52

Power take-off	
PTO type	Shiftable
Speeds	540/540E rpm - 540/1000 rpm - 540/540E/1000 rpm
Speed selector control	Electrohydraulic

Front axle	
Front axle type	4-wheel drive
Brand	CARRARO 20.16
Speed	40 km/h
Synchronization ratio (displayed on the name plate)	1.326

Hydraulics	
Hydraulic type	57 l or 98 l Open Center
Number of spool valves	0-1-2-3

Environment	
Operator environment	

1.1.3 MF 5710 Dyna-4 model

Engine	
Brand	AGCO Power
Type	Tier 4F/Stage IV SCR Technology engine
Model	44AWFC
Number of cylinders	4
Maximum ISO power (HP)	100
Maximum torque (Nm)	410

gearbox	
GBA50 - 16X16 with 4 powershift ratios and shuttle Power Shuttle Control	

Rear axle type	
GPA50 - P144B	

Final drive type	
GPA52	

Power take-off	
PTO type	Shiftable
Speeds	540/540E rpm - 540/1000 rpm - 540/540E/1000 rpm
Speed selector control	Electrohydraulic

Front axle	
Front axle type	4-wheel drive
Brand	CARRARO 20.19
Speed	40 km/h
Synchronization ratio (displayed on the name plate)	1.326

Hydraulics	
Hydraulic type	57-l or 98-l Open Center
Number of spool valves	0-1-2-3

Environment	
Operator environment	

1.1.4 MF 5711 Dyna-4 model

Engine	
Brand	AGCO Power
Type	Tier 4F/Stage IV SCR Technology engine
Model	44AWFC
Number of cylinders	4
Maximum ISO power (HP)	110
Maximum torque (Nm)	417

gearbox	
GBA50 - 16X16 with 4 powershift ratios and shuttle Power Shuttle Control	

Rear axle type	
GPA50 - P144B	

Final drive type

GPA54

Power take-off

Type of power take-off	Shiftable
Speeds	540/540E rpm - 540/1000 rpm - 540/540E/1000 rpm
Speed selector control	Electrohydraulic

Front axle

Front axle type	4-wheel drive
Brand	CARRARO 20.19
Speed	40 km/h
Synchronization ratio (displayed on the name plate)	1.326

Hydraulics

Hydraulic type	Open center
Number of spool valves	0-1-2-3

Environment

Operator environment

1.2 Forward speeds

1.2.1 Forward speed at 2200 tr/min with GPA 52 gearbox and 16.9R38 tires.

Forward and reverse travel, Dyna-4 transmission

Range	Ratio	GPA52	
		Without creeper gears engaged	With creeper gears engaged
1	A	2,07 km/h	0,15 km/h
1	B	2,54 km/h	0,19 km/h
1	C	3,14 km/h	0,23 km/h
1	D	3,85 km/h	0,28 km/h
2	A	5,09 km/h	0,37 km/h
2	B	6,24 km/h	0,46 km/h
2	C	7,71 km/h	0,56 km/h
2	D	9,45 km/h	0,69 km/h
3	A	10,64 km/h	0,78 km/h
3	B	13,05 km/h	0,95 km/h
3	C	16,14 km/h	1,18 km/h
3	D	19,78 km/h	1,45 km/h
4	A	25,21 km/h	1,84 km/h
4	B	30,91 km/h	2,26 km/h
4	C	38,23 km/h	2,79 km/h
4	D	40 km/h	3,43 km/h

1.2.2 Forward speed at 2200 tr/min with GPA 54 gearbox and 16.9R38 tires.

Forward and reverse travel, Dyna-4 transmission

Range	Ratio	GPA 54	
		Without creeper gears engaged	With creeper gears engaged
1	A	2,07 km/h	0,15 km/h
1	B	2,54 km/h	0,19 km/h
1	C	3,14 km/h	0,23 km/h
1	D	3,85 km/h	0,28 km/h
2	A	5,09 km/h	0,37 km/h
2	B	6,24 km/h	0,46 km/h
2	C	7,71 km/h	0,56 km/h
2	D	9,45 km/h	0,69 km/h
3	A	10,64 km/h	0,78 km/h
3	B	13,05 km/h	0,95 km/h
3	C	16,14 km/h	1,18 km/h

Range	Ratio	GPA 54	
		Without creeper gears engaged	With creeper gears engaged
3	D	19,78 km/h	1,45 km/h
4	A	25,21 km/h	1,84 km/h
4	B	30,91 km/h	2,26 km/h
4	C	38,23 km/h	2,79 km/h
4	D	40 km/h	3,43 km/h

1.3 Dimensions and weights

1.3.1 Dimensions and weights

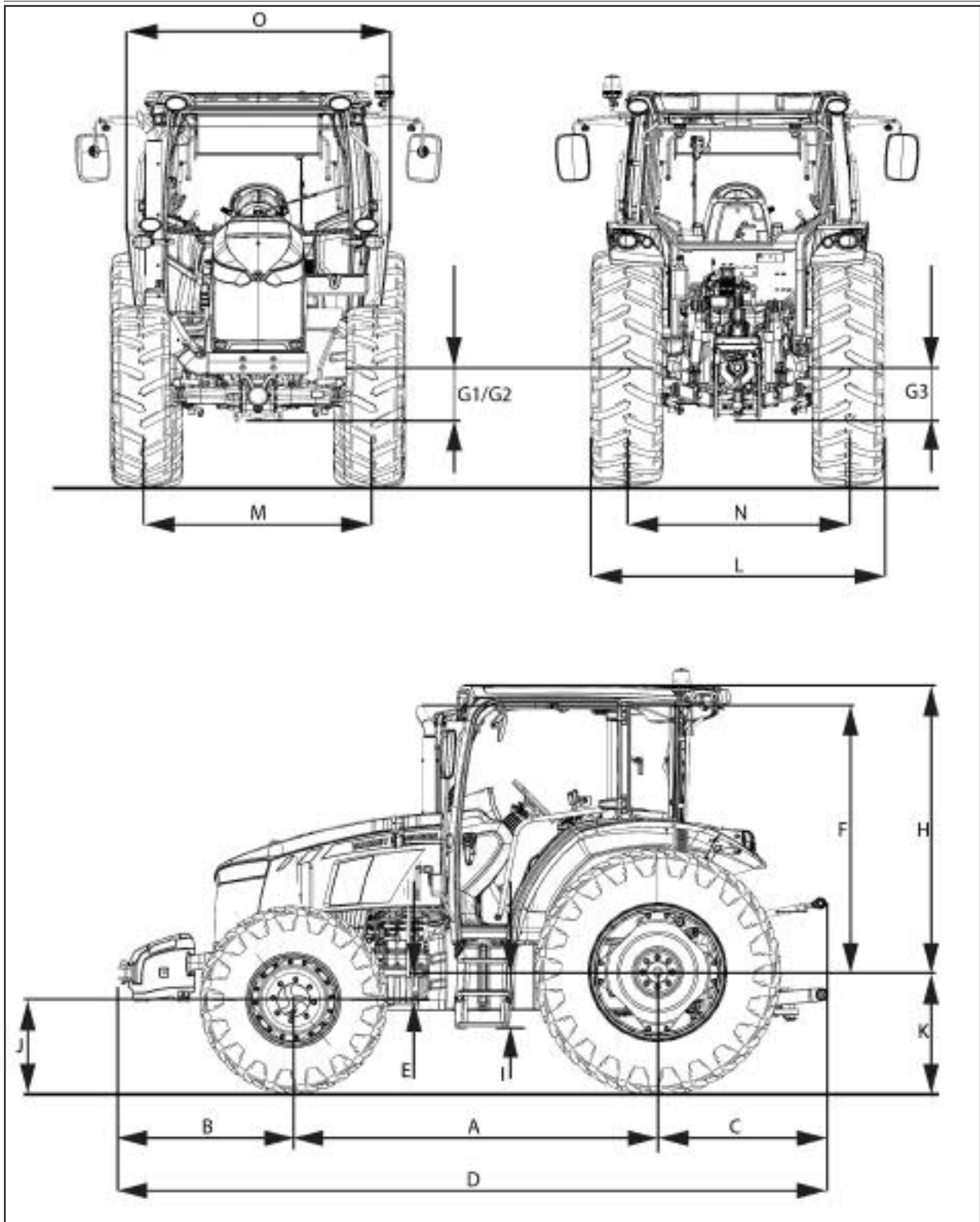

Fig. 1

Reference	Dimensional specifications	3 cylinders
(A)	Wheel base	2320 mm
(B)	Front overhang without weights	675 mm
(B)	Front overhang with weights only	1125 mm
(B)	Front overhang with hitch weights	1195 mm
(C)	Rear overhang with horizontal linkage	1200 mm
(D)	External length without weight	4305 mm
(D)	External length with weights only	4755 mm
(D)	External length with hitch weights	4825 mm
(E)	Difference in height between the front and rear wheel shafts (4-wheel drive)	185 mm
(F)	Height between rear axle shaft and end of the standard exhaust	1778 mm
(G1)	Height between rear axle shaft and low point of front axle (4-wheel drive)	320 mm
(G3)	Height between rear axle shaft and hitch at the lowest point	392 mm
(H)	Distance between rear wheel axle and top of roof - standard mounted cab tractor (with rotary beacon, add 157 mm)	1915 mm
(I)	Distance between rear wheel axle and bottom of ladder - standard mounted cab tractor	368 mm
(J)	Minimum and maximum radii of the front wheels	525 mm to 650 mm
(K)	Minimum and maximum radii of the rear wheels	700 mm to 800 mm
(L)	External width	1821 mm to 2110 mm
(M)	Front track width	4-wheel drive: 1300 mm to 1860 mm
(N)	Rear track width	1320 mm to 1800 mm
(O)	Distance between the fenders (with extension, add 250 mm)	1821 mm

Reference	Dimensional specifications	4 cylinders
(A)	Wheel base	2430 mm
(B)	Front overhang without weights	675 mm
(B)	Front overhang with weights only	1125 mm
(B)	Front overhang with hitch weights	1195 mm
(C)	Rear overhang with horizontal linkage	1200 mm

Thank you so much for reading.
Please click the “Buy Now!”
button below to download the
complete manual.



After you pay.

You can download the most
perfect and complete manual in
the world immediately.

Our support email:

ebooklibonline@outlook.com