

Operator's Manual

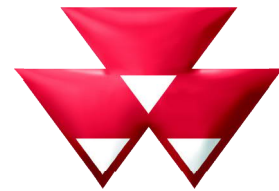

MASSEY FERGUSON

GC1700 Series Compact Tractor

GC1723E

GC1725M

North America
4205 River Green Parkway, Duluth GA 30096 USA
© AGCO 2018
Original Operator's Manual

October 2018
ACW7152790
NA
English

GC1700 Series Compact Tractor

1	Safety	7
1.1	Introduction	9
1.1.1	Safety alert symbol	9
1.1.2	Safety messages	9
1.1.3	Information messages	9
1.1.4	Safety signs	9
1.1.5	A word to the operator	10
1.1.6	This manual	11
1.2	Operation	12
1.2.1	Prepare for operation	12
1.2.2	Roll over protective structure	12
1.2.3	General information	12
1.2.4	Personal protective equipment	16
1.2.5	Seat instruction	16
1.2.6	Shield and guards	16
1.2.7	Power take-off safety	17
1.2.8	Exhaust warning	18
1.2.9	Flying debris	18
1.2.10	Agricultural chemicals	18
1.3	Travel on public roads	19
1.4	Maintenance	21
1.4.1	General maintenance information	21
1.4.2	Fire prevention and first aid	22
1.4.3	High pressure leaks	23
1.4.4	Engine safety	24
1.4.5	Fuel safety	25
1.4.6	Battery safety	26
1.4.7	Tire safety	27
1.4.8	Replacement parts	27
1.4.9	Weld on the machine precautions	28
1.5	Safety and informational signs	29
1.5.1	Safety and informational signs location	29
1.5.2	Safety signs description	30
1.5.3	Warning - state of California	30
1.5.4	Electrical hazard	30
1.5.5	Hot surface	30
1.5.6	Hot pressurized coolant	31
1.5.7	Entanglement hazard - belt	31
1.5.8	Explosion and/or fire hazard - starting fluid	31
1.5.9	Shear hazard - engine fan	31
1.5.10	Run over hazard	32
1.5.11	Fuel	32
1.5.12	Flammable fuel	32
1.5.13	Roll-over hazard	32
1.5.14	Roll-over crush hazard	33
1.5.15	Operators manual	33
1.5.16	Shut off engine	33
1.5.17	Movement hazard	33
1.5.18	Crush hazard	34
1.5.19	Roll-over crush hazard - slope	34
1.5.20	Fall off or run-over hazard	34

1.5.21	Entanglement hazard - power take off	34
1.5.22	Rear rollover hazard	35
1.5.23	Component separation flying object	35
2	Introduction	37
2.1	Introduction	39
2.1.1	Intended use	39
2.1.2	Proper disposal of waste	39
2.2	Machine identification	40
2.2.1	Serial number plate	40
2.2.2	Engine identification	41
2.2.3	Chassis number	41
2.3	Machine components	42
2.3.1	Machine components	42
2.4	California emission control warranty statement	43
2.5	United States and Canada emission control warranty statement	47
3	Operation	51
3.1	Machine operation controls	53
3.1.1	Locations of controls	53
3.2	Instrument panel and components	54
3.2.1	Instrument panel	54
3.2.1.1	Indicators and gauges	54
3.2.2	Main switch	56
3.2.3	Lamp switches	56
3.3	Brake pedal and parking brake	57
3.4	Seat	58
3.4.1	Adjust the seat	58
3.4.2	Rotate the seat for backhoe operation	58
3.4.3	Rotate the seat for tractor operation	59
3.5	Steering wheel	61
3.5.1	Adjust the steering wheel tilt	61
3.5.2	Adjust the steering wheel tilt lever	61
3.6	Electrical power outlet - 12V socket	63
3.7	Engine cover	64
3.7.1	Open the engine cover	64
3.8	Break-in the tractor	65
3.9	Start the tractor	66
3.9.1	Examine before operation	66
3.9.2	Start the tractor - normal conditions	67
3.9.3	Cold weather starting	68
3.9.4	Warm engine starting	68
3.9.5	Warm up period	69
3.9.6	General operating information	69
3.9.7	Examine the neutral start system	69
3.10	Engine speed control	71
3.11	Ground speed controls	72
3.11.1	Range gear shift lever	72
3.11.2	Hydrostatic control pedals	72
3.11.3	Ground speed chart	73
3.11.4	Set the cruise control lever	73
3.12	Stop the engine	75
3.13	Engage the differential lock	76
3.14	Four-wheel drive	77

3.15	Power take-off	78
3.15.1	Power take-off controls	78
3.15.2	Rear power take-off shaft	79
3.15.3	Mid power take-off shaft	80
3.16	3-point linkage	81
3.16.1	3-point linkage controls	81
3.16.2	3-point linkage	83
3.16.3	Connect implements	83
3.16.4	Disconnect implements	84
3.17	Joystick, if equipped	85
3.17.1	Joystick control lever	85
3.17.2	Joystick operation	85
3.17.3	Joystick control lever lockout	86
3.17.4	Hydraulic ports	87
3.18	Roll-over protective structure	88
3.19	Transport on a trailer	89
4	Maintenance	91
4.1	Lubrication and maintenance	93
4.1.1	Lubrication and maintenance chart for daily inspection	93
4.1.2	Lubrication and maintenance chart	93
4.1.3	Lubrication fill and drain locations	95
4.1.4	Lubrication fittings	95
4.2	Engine oil and filter	96
4.2.1	Examine the engine oil	96
4.2.2	Change the engine oil	97
4.2.3	Replace the engine oil filter	98
4.3	Transmission oil	100
4.3.1	Examine the transmission oil level	100
4.3.2	Change the transmission oil and filter	100
4.4	Front axle oil	103
4.4.1	Examine the front axle oil level	103
4.4.2	Change the front axle oil	103
4.5	Engine coolant	105
4.5.1	Coolant	105
4.5.2	Coolant level	105
4.5.3	Replace the engine coolant	106
4.6	Engine belt	107
4.6.1	Adjust the engine belt	107
4.7	Engine air filter	108
4.7.1	Clean the engine air filter	108
4.8	Fuel system	110
4.8.1	Fuel filter	110
4.8.2	Replace the fuel filter	110
4.8.3	Remove air from the fuel system	111
4.8.4	Fuel tank filler cap	111
4.8.5	Fuel system components	112
4.8.6	Hand throttle lever	112
4.9	Electrical system	113
4.9.1	Battery	113
4.9.2	Replace the battery	114
4.9.3	Start the engine with a booster battery	115
4.9.4	Fuses	116
4.9.4.1	Fuses locations	116
4.9.5	Neutral start switches	118

4.9.6	Spare power supply	118
4.10	Adjust the brakes	119
4.11	Hydrostatic adjustments	120
4.12	Wheels and tires	121
4.12.1	Tire inflation pressures	121
4.12.2	Wheel bolt torque	121
4.12.2.1	Wheel bolt torque chart	121
4.12.3	Adjust the front wheel alignment	122
4.12.4	Steering free play	122
4.13	Prepare tractor for storage	123
4.14	Power washing	124
5	Troubleshooting	125
5.1	Engine troubleshooting	127
5.2	Brakes troubleshooting	131
5.3	Hydraulic system troubleshooting	132
5.4	Steering system troubleshooting	133
5.5	Electrical system troubleshooting	134
5.6	Hydrostatic transmission troubleshooting	135
6	Specifications	137
6.1	Specifications	139
6.1.1	Lubrication specifications	139
6.1.2	Capacities	139
6.1.3	Engine specifications	140
6.1.4	Electrical specifications	141
6.1.5	Fuel specifications	141
6.1.6	Front axle specifications	141
6.1.7	Hydraulic specifications	141
6.1.8	Power take-off specifications	142
6.1.9	Transmission specifications	142
6.1.10	Maximum load capacity	143
6.1.11	Tire inflation pressures	143
6.2	Dimensions	144
6.2.1	Tractor dimensions	144
6.3	Bolt torque	146
6.3.1	Bolt torque chart	146
6.3.2	Wheel bolt torque chart	146
7	Accessories	147
7.1	Accessories	149
7.1.1	Canopy	149
7.1.2	Engine block heater	149
7.1.3	Implements and attachments	149
8	Assembly	151
8.1	Checklists	153
8.1.1	Pre-delivery checklist	153
8.1.2	Delivery checklist	153
9	Index	155

1 Safety

1.1	Introduction	9
1.1.1	Safety alert symbol	9
1.1.2	Safety messages	9
1.1.3	Information messages	9
1.1.4	Safety signs	9
1.1.5	A word to the operator	10
1.1.6	This manual	11
1.2	Operation	12
1.2.1	Prepare for operation	12
1.2.2	Roll over protective structure	12
1.2.3	General information	12
1.2.4	Personal protective equipment	16
1.2.5	Seat instruction	16
1.2.6	Shield and guards	16
1.2.7	Power take-off safety	17
1.2.8	Exhaust warning	18
1.2.9	Flying debris	18
1.2.10	Agricultural chemicals	18
1.3	Travel on public roads	19
1.4	Maintenance	21
1.4.1	General maintenance information	21
1.4.2	Fire prevention and first aid	22
1.4.3	High pressure leaks	23
1.4.4	Engine safety	24
1.4.5	Fuel safety	25
1.4.6	Battery safety	26
1.4.7	Tire safety	27
1.4.8	Replacement parts	27
1.4.9	Weld on the machine precautions	28
1.5	Safety and informational signs	29
1.5.1	Safety and informational signs location	29
1.5.2	Safety signs description	30
1.5.3	Warning - state of California	30
1.5.4	Electrical hazard	30
1.5.5	Hot surface	30
1.5.6	Hot pressurized coolant	31
1.5.7	Entanglement hazard - belt	31
1.5.8	Explosion and/or fire hazard - starting fluid	31
1.5.9	Shear hazard - engine fan	31
1.5.10	Run over hazard	32
1.5.11	Fuel	32
1.5.12	Flammable fuel	32
1.5.13	Roll-over hazard	32
1.5.14	Roll-over crush hazard	33
1.5.15	Operators manual	33
1.5.16	Shut off engine	33
1.5.17	Movement hazard	33
1.5.18	Crush hazard	34
1.5.19	Roll-over crush hazard - slope	34
1.5.20	Fall off or run-over hazard	34

1.5.21	Entanglement hazard - power take off	34
1.5.22	Rear rollover hazard	35
1.5.23	Component separation flying object	35

1.1 Introduction

1.1.1 Safety alert symbol

The safety alert symbol means Attention! Become Alert! Your Safety Is Involved!

Look for the safety alert symbol both in this manual and on safety signs on this machine. The safety alert symbol will direct your attention to information that involves your safety and the safety of others.



Fig. 1

1.1.2 Safety messages

The words DANGER, WARNING or CAUTION are used with the safety alert symbol. Learn to recognize these safety alerts and follow the recommended precautions and safety practices.



DANGER:
Indicates an imminently hazardous situation that, if not avoided, will result in DEATH OR VERY SERIOUS INJURY.



WARNING:
Indicates a potentially hazardous situation that, if not avoided, could result in DEATH OR SERIOUS INJURY.



CAUTION:
Indicates a potentially hazardous situation that, if not avoided, may result in MINOR INJURY.



Fig. 2

1.1.3 Information messages

The words important and note are not related to personal safety, and are used to give information about the operation and servicing of the machine.

IMPORTANT: Identifies special instructions or procedures which, if not followed, can cause damage to the machine, the process, or the area around the machine.

NOTE: Information to make procedures easier.

1.1.4 Safety signs



WARNING:
Do not remove the safety signs. Replace safety signs that you cannot read, are damaged, or are missing.

Clean the machine surface with a weak soap and water solution before you replace the safety signs. Replacement safety signs are available from your dealer.

Always make sure that safety signs are in the correct locations and that you can read the safety signs. Illustrations of safety sign locations are at in this section.

Keep the safety signs clean. If necessary, use a weak soap and water solution.

1.1.5 A word to the operator

It is your responsibility to read and understand the safety section in this manual and the manual for all implements before you operate this machine. You are responsible for your safety. Good safety procedures prevent injury to you and the persons around you.

Make the information in the safety section of this manual a part of your safety procedure. This safety section is written only for this type of machine. Safety is your responsibility. You can prevent injury and death.

This safety section gives basic safety examples that can occur during the operation and maintenance of your machine. This safety section is not a replacement for safety instruction in other sections of this manual.

Injury or death can occur if the safety instruction is not obeyed.

Learn how to operate the machine and how to use the controls correctly.

Do not operate the machine if you do not know how to operate the machine. Do not let persons operate the machine that do not know how to operate the machine.

Follow all safety instructions in the manuals and on the safety signs on the machine, the implements, and the attachments.

Use only approved attachments and implements.

Make sure that your machine has the correct equipment that is necessary by the local regulations.

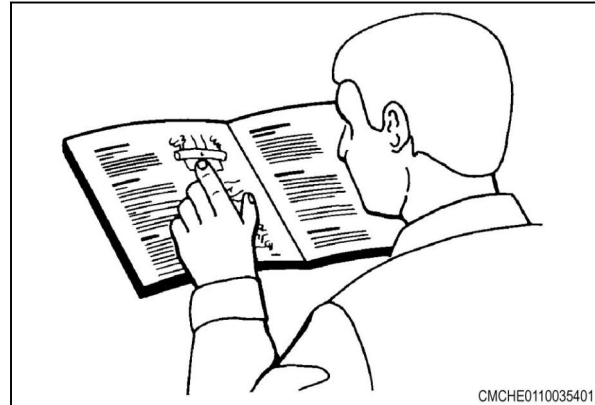

Fig. 3



WARNING:

Do not use alcohol or drugs that can have an effect on alertness or coordination. If you use prescription or 'over the counter' drugs, get medical advice about the safe operation of machines.



CAUTION:

If attachments or implements used with this machine have a different operator manual, see that operator manual for other important safety instructions.

1.1.6 This manual

This manual covers general safety instructions for this machine. Keep this manual with the machine.

Right and left, as used in this manual, are given as if you are in the operator seat.

The photos, illustrations, and data used in this manual were up to date when published, but in-line production changes can make your machine have small differences. The manufacturer reserves the right to redesign and change the machine as necessary without notification.



WARNING:

In some of the illustrations and photos used in this manual, shields or guards are removed. Operate the machine only with all shields and guards in the correct installed positions. If the removal of shields or guards is necessary to make a repair, they must be installed before operation.

1.2 Operation

1.2.1 Prepare for operation

Read and understand all operation instructions and precautions in this manual before you operate the machine or do the servicing.

Make sure that you know and understand the positions and operations of all controls. Make sure that all controls are in neutral and that the parking brake is applied before you start the machine.

Make sure that all persons are away from your area of work before you start and operate the machine. Examine and learn the controls in an area that is clear of persons and obstacles before you start work. Know the machine dimensions and make sure that you have sufficient space available to operate the machine. Do not operate the machine at high speeds in crowded areas.

It is important to know and use the correct procedures when you do work around and operate the machine. Do not let children or unqualified persons operate the machine. Keep others, especially children, away from your area of work. Do not let others to ride on the machine.

Make sure that the machine is in good condition for operation. Refer to the operator manual. Make sure that the machine has the correct equipment required by local regulations.

1.2.2 Roll over protective structure

The roll over protective structure (ROPS) is effective in reducing injuries during overturns. Overturning a tractor without ROPS or with the ROPS folded down can result in serious injury or death. Operate with ROPS folded down only when conditions make this necessary. Return ROPS to upright, locked position as soon as conditions permit.

Do not weld, drill, or alter the ROPS.

If the tractor has been rolled over or the ROPS frame has been damaged in any manner, the ROPS must be replaced. Do not attempt to repair a damaged ROPS. If damage does occur, consult your dealer and replace all damaged parts.

Before using the tractor make sure the ROPS frame is not damaged and it is securely fastened to the tractor .

Do not attach chains, ropes, or cables to the ROPS for pulling purposes - damage to the ROPS and/or overturn of the tractor may result. Always pull from the tractor drawbar.

Observe all recommendations and instructions regarding the installation of covers or roofs which are used as sunshields only, and do not afford the operator protection from falling objects.

1.2.3 General information

When parking, park the machine on a solid level surface and lower any implements to the ground. Put all controls in neutral and apply the park brake. Stop the engine and take the key with you.



WARNING:
Do not leave the machine unattended with any implement or attachment in the raised position. Lower the implement or attachment fully before leaving the machine. A sudden loss of hydraulic pressure can cause the implement or attachment to drop without warning.

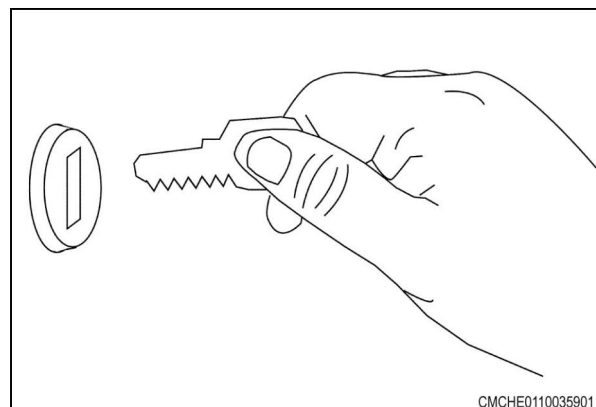

Fig. 4

Make sure the machine is in the proper operating condition according to the Operator Manual.

Do not dismount from moving machinery.

Stay off slopes too steep for operation.

Be aware of the size of the machine and have enough space available to allow for operation.

Do not operate near the edge of banks. Setback distance from the bank must equal or exceed, the overall height of the bank.

Whenever possible, travel directly up or down slopes, keeping the heavy end of the tractor on the uphill side. If necessary to cross a steep slope, avoid turning uphill. Slow down and make a wide turn.

Do not operate on steep slopes as overturn may result.

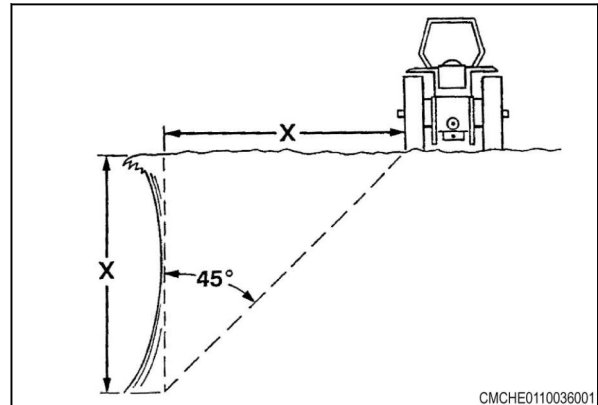

Fig. 5

On models with independent brake pedals, keep the brake pedals latched together at all times unless independent braking is required. Never use independent braking during transport.

Always drive at a proper speed relative to local conditions and ensure your speed is low enough for an emergency stop.

Reduce speed prior to turns to avoid the risk of overturning.

Keep speed to a minimum.

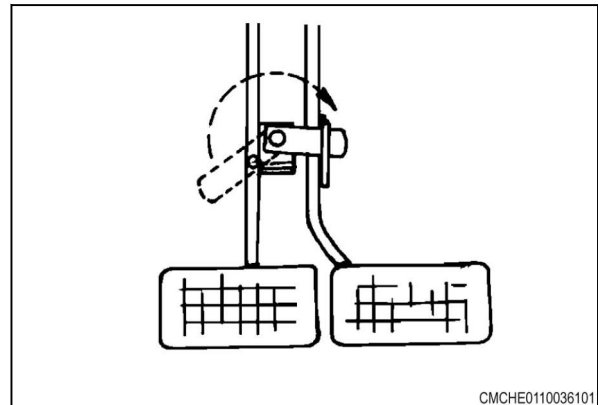

Fig. 6

Always keep the tractor in gear to provide engine braking when going downhill. Do not coast.

Avoid sudden or heavy brake applications when operating in wet, muddy, or icy ground conditions, or on loose surfaces, such as sand or gravel.

Sudden or heavy braking during turns increases the tendency to over steer. This effect is more pronounced with trailed equipment.

Keep a firm grip on the steering wheel at all times, with the thumbs clear of the spokes when driving the tractor.

Remain seated in operator's seat.

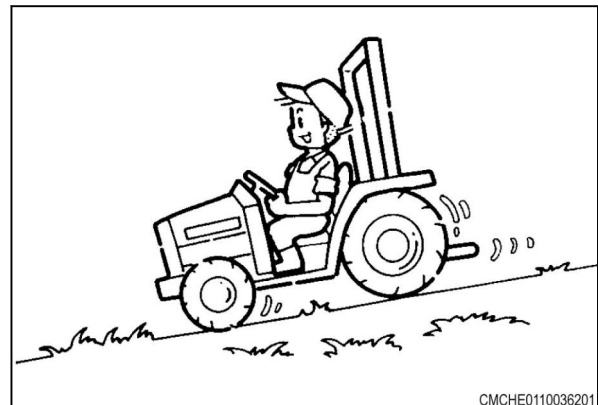

Fig. 7

1. Safety



In the event of an overturn, hold the steering wheel firmly and keep your seat belt fastened. Do not attempt to leave the seat until the tractor has come to rest.

Watch for holes, rocks, or other hidden hazards. Always inspect area prior to operation.

Be observant of the operating area and terrain.

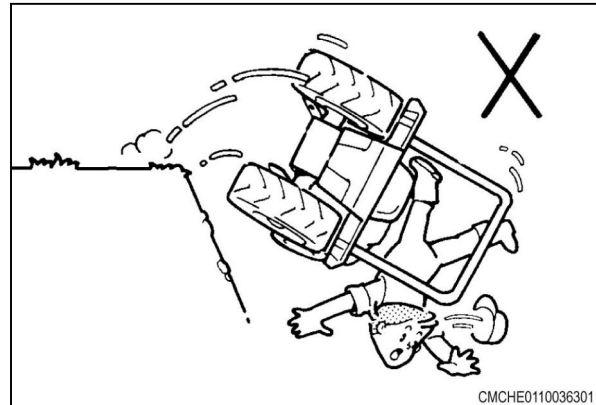

Fig. 8

Avoid contact with electrical power lines. Contact with electrical power lines can cause electrical shock, resulting in very serious injury or death.

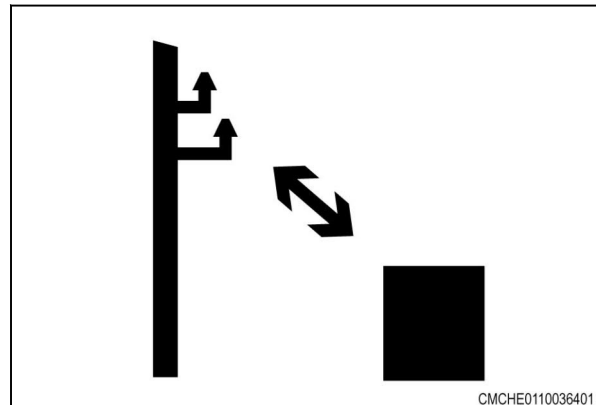

Fig. 9

Never allow anyone on any part of the tractor or attachments except in the operator's seat when the engine is running.

Do not get on or off the tractor or attachments while the tractor is moving.

Do not carry passengers.



Fig. 10

Always shut off the engine, shift the transmission to neutral, set park brake and remove the start key before leaving the operator's seat or before permitting anyone to inspect, clean, lubricate, adjust or repair any part of the tractor or attachments. Never leave the tractor unattended while the engine is operating.

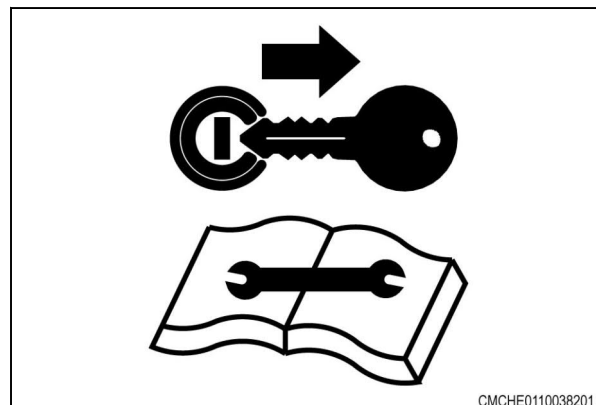

Fig. 11

Pull only from the approved drawbar.

Towing or attaching to other locations may cause the tractor to overturn.

Use a safety transport chain with towed implements. A safety transport chain connecting the tractor to the implement will help control pull-type equipment should it accidentally separate from the drawbar.

Always attach the safety transport chain to the tractor drawbar support.

Provide only enough slack in the safety transport chain to permit turning. See your dealer for a chain with strength rating equal to or greater than the gross weight of the towed machine.

For towed equipment without brakes, Do not tow equipment at speeds over 32 km/h (20 mph). Do not tow equipment that, when fully loaded, weighs more 1.5 times the weight of the towing unit.

For towed equipment with brakes, Do not tow equipment at speeds over 40 km/h (25 mph). Do not tow equipment that, when fully loaded, weighs more than 4.5 times the weight of the towing unit.

Stopping distance increases with speed and weight of towed loads, and on hills and slopes. Towed loads with or without brakes, that are too heavy for the tractor or are towed too fast, can cause loss of control. Consider the total weight of the equipment and load.

When using a loader attachment, to avoid serious injury or death due to falling loads resulting from inadvertent raising or roll-back of the loader, do not connect loader hydraulics to any tractor auxiliary valve that has detents which cannot be locked out or removed, except for the float function in the loader lower circuit. If the tractor is equipped with such a valve, a dedicated, properly configured loader valve must be installed.

Make sure the proper attachment is on the loader so the load is restrained and cannot roll down the loader arms onto the operator.

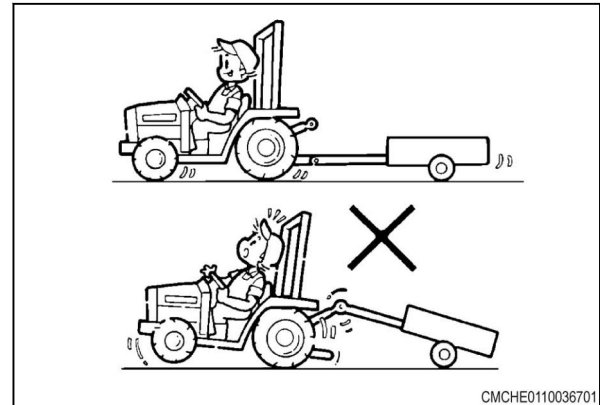

Fig. 12

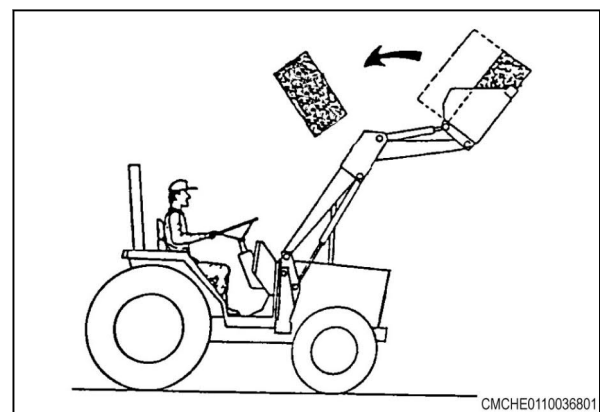

Fig. 13

Related Links

[Maximum load capacity](#) page 143

1.2.4 Personal protective equipment

Put on all personal protective equipment (PPE) and protective clothes that are supplied to you or that are necessary for the conditions and by applicable laws. PPE includes equipment to prevent injury to your eyes, lungs, ears, head, hands and feet.

Always keep hands, feet, hair, and your clothes away from parts that move. Do not put on loose clothing, jewelry, watches, or other items that can tangle in parts that move. Tie up long hair that can also tangle in moving parts.

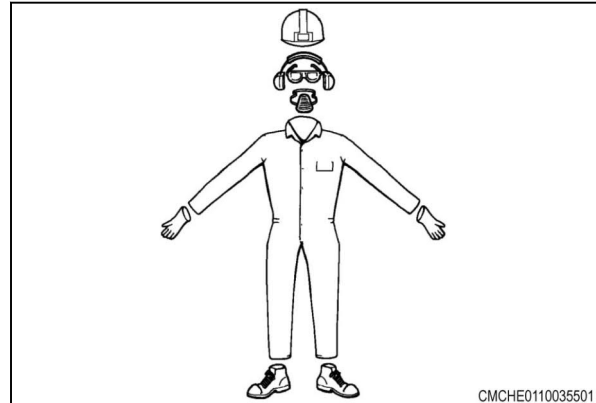

Fig. 14

1.2.5 Seat instruction

Securely fasten the seat belt before operating the machine. Always remain seated and have the seat belt fastened while operating the machine when the roll over protective structure (ROPS) is in the upright position. Replace the seat belts when they become worn or broken.

Never wear a seat belt loosely or with slack in the belt system. Never wear the seat belt in a twisted condition or pinched between the seat structural members.

Do not wear the seat belt when the ROPS is folded down.

Do not adjust the steering column or seat while driving.

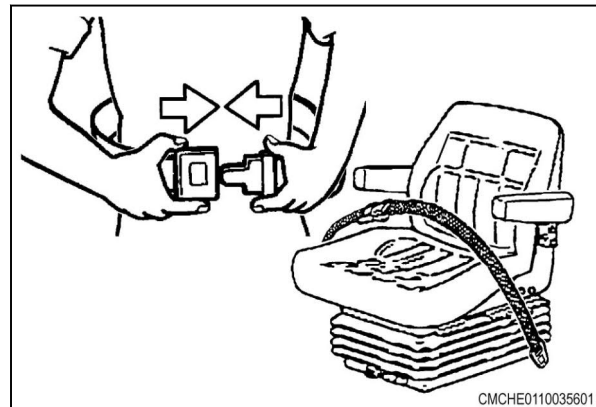

Fig. 15

1.2.6 Shield and guards



**WARNING: Entanglement hazard.
Belts and components that rotate.**

Severe personal injury or death can occur.

Do not open, remove, or put your hand behind shields if the engine is running. Stop the machine before doing service to the machine.

All shields and guards must be in the correct position and in good condition. Keep away from the components that rotate.

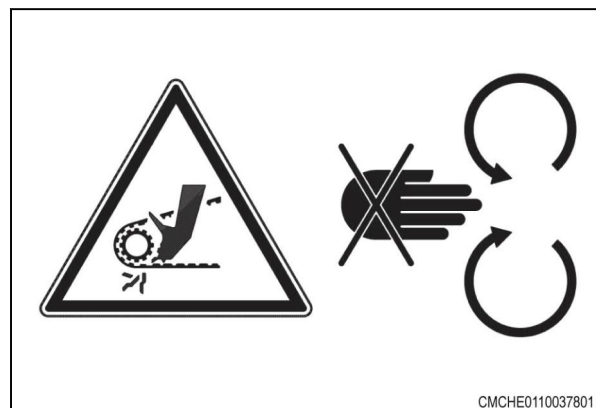

Fig. 16

Thank you so much for reading.
Please click the “Buy Now!”
button below to download the
complete manual.



After you pay.

You can download the most
perfect and complete manual in
the world immediately.

Our support email:

ebooklibonline@outlook.com