



2017

⚠ Read this manual carefully before operating this vehicle.

⚠ Il convient de lire attentivement ce manuel avant la première utilisation du véhicule.

⚠ Bitte lesen Sie diese Bedienungsanleitung sorgfältig durch, bevor Sie das Fahrzeug in Betrieb nehmen.

**OWNER'S SERVICE MANUAL**

**MANUEL D'ATELIER DU  
PROPRIETAIRE**

**FAHRER- UND  
WARTUNGSHANDBUCH**

***YZ250FX***  
***YZ250FXH***

**B29-28199-82**



**YAMAHA**

**2017**

**⚠ Read this manual carefully before operating this vehicle.**

**OWNER'S SERVICE MANUAL**

***YZ250FX***  
***YZ250FXH***

**B29-28199-82-E0**

---

# TABLE OF CONTENTS

<b>GENERAL INFORMATION</b>	<b>1</b>
<b>SPECIFICATIONS</b>	<b>2</b>
<b>PERIODIC CHECKS AND ADJUSTMENTS</b>	<b>3</b>
<b>CHASSIS</b>	<b>4</b>
<b>ENGINE</b>	<b>5</b>
<b>COOLING SYSTEM</b>	<b>6</b>
<b>FUEL SYSTEM</b>	<b>7</b>
<b>ELECTRICAL SYSTEM</b>	<b>8</b>
<b>TROUBLESHOOTING</b>	<b>9</b>
<b>TUNING</b>	<b>10</b>

---

## GENERAL INFORMATION

<b>LOCATION OF IMPORTANT LABELS</b> .....	1-1
<b>DESCRIPTION</b> .....	1-4
<b>IDENTIFICATION</b> .....	1-5
VEHICLE IDENTIFICATION NUMBER .....	1-5
ENGINE SERIAL NUMBER .....	1-5
<b>INCLUDED PARTS</b> .....	1-6
SPARK PLUG WRENCH .....	1-6
NIPPLE WRENCH.....	1-6
HANDLEBAR PROTECTOR.....	1-6
FUEL HOSE JOINT COVER.....	1-6
COUPLER FOR CONNECTING OPTIONAL PART.....	1-6
<b>IMPORTANT INFORMATION</b> .....	1-7
PREPARATION FOR REMOVAL AND DISASSEMBLY.....	1-7
REPLACEMENT PARTS.....	1-7
GASKETS, OIL SEALS AND O-RINGS .....	1-8
LOCK WASHERS/PLATES AND COTTER PINS .....	1-8
BEARINGS AND OIL SEALS .....	1-8
CIRCLIPS .....	1-8
<b>BASIC SERVICE INFORMATION</b> .....	1-9
ELECTRICAL SYSTEM.....	1-9
<b>SPECIAL TOOLS</b> .....	1-13
<b>CONTROL FUNCTIONS</b> .....	1-19
WARNING LIGHTS .....	1-19
ENGINE STOP SWITCH.....	1-19
START SWITCH.....	1-19
CLUTCH LEVER .....	1-19
SHIFT PEDAL .....	1-20
THROTTLE GRIP .....	1-20
FRONT BRAKE LEVER .....	1-20
REAR BRAKE PEDAL.....	1-20
SIDESTAND .....	1-20
STARTER KNOB/IDLE ADJUSTING SCREW.....	1-20
FUEL TANK CAP .....	1-21

---

<b>STARTING AND BREAK-IN .....</b>	<b>1-22</b>
FUEL .....	1-22
HANDLING NOTE .....	1-22
AIR FILTER MAINTENANCE .....	1-22
STARTING A COLD ENGINE .....	1-22
STARTING A WARM ENGINE .....	1-23
BREAK-IN PROCEDURES .....	1-23
<b>MAINTENANCE AFTER BREAK-IN .....</b>	<b>1-24</b>
MAJOR MAINTENANCE .....	1-24
<b>TORQUE-CHECK POINTS .....</b>	<b>1-25</b>
<b>MOTORCYCLE CARE AND STORAGE .....</b>	<b>1-27</b>
CARE .....	1-27
STORAGE .....	1-28

# LOCATION OF IMPORTANT LABELS

## LOCATION OF IMPORTANT LABELS

Please read the following important labels carefully before operating this vehicle.

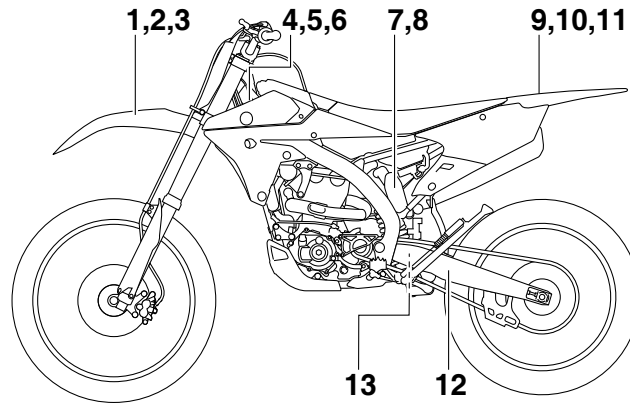

### CAN

1

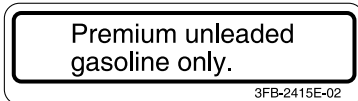

5

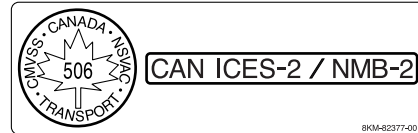

2

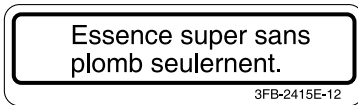

7

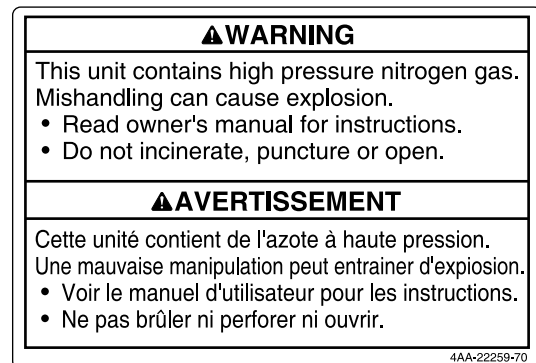

3

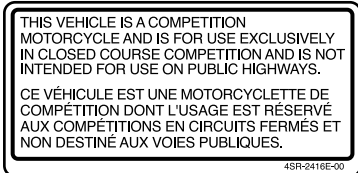

4

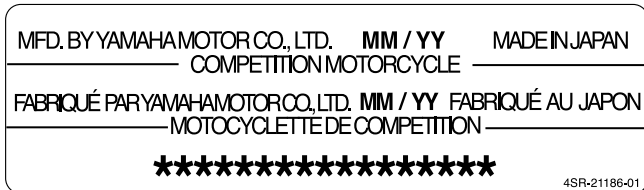

# LOCATION OF IMPORTANT LABELS

9

**⚠ WARNING**

- BEFORE YOU OPERATE THIS VEHICLE, READ THE OWNER'S MANUAL AND ALL LABELS.
- NEVER CARRY A PASSENGER. You increase your risk of losing control if you carry a passenger.
- NEVER OPERATE THIS VEHICLE ON PUBLIC ROADS. You can collide with another vehicle if you operate this vehicle on a public road.
- ALWAYS WEAR AN APPROVED MOTORCYCLE HELMET, eye protection, and protective clothing.
- EXPERIENCED RIDER ONLY.

5PA-2118K-00

12

**TIRE INFORMATION**

Cold tire normal pressure should be set as follows:  
 FRONT: 100kPa, {1.00kgf/cm<sup>2</sup>}, 15psi  
 REAR : 100kPa, {1.00kgf/cm<sup>2</sup>}, 15psi

3RV-21668-A0

10

**⚠ AVERTISSEMENT**

- LIRE LE MANUEL DU PROPRIETAIRE AINSI QUE TOUTES LES ETIQUETTES AVANT D'UTILISER CE VEHICULE.
- NE JAMAIS TRANSPORTER DE PASSAGER. La conduite avec passager augmente les risques de perte de contrôle.
- NE JAMAIS ROULER SUR DES CHEMINS PUBLICS. Vous pourriez entrer en collision avec un autre véhicule.
- TOUJOURS PORTER UN CASQUE DE MOTOCYCLISTE APPROUVE, des lunettes et des vêtements de protection.
- EXCLUSIVEMENT POUR L'USAGE D'UN CONDUCTEUR EXPERIMENTE.

5PA-2118K-10

13

**INFORMATION SUR LES PNEUS**

La pression des pneus à froid doit normalement être réglée comme suit.  
 AVANT : 100kPa, {1.00kgf/cm<sup>2</sup>}, 15psi  
 ARRIERE : 100kPa, {1.00kgf/cm<sup>2</sup>}, 15psi

3RV-21668-B0

EUR

6





**CE**

YAMAHA MOTOR CO., LTD.  
 SHIZUOKA JAPAN

YAMAHA 4GB-2155A-00

11

**⚠**

100 kPa      100 kPa  
 1.00 kgf/cm<sup>2</sup>      1.00 kgf/cm<sup>2</sup>  
 15 psi      15 psi

5PG-2816R-00

8



# LOCATION OF IMPORTANT LABELS

AUS, NZL, ZAF

8



12

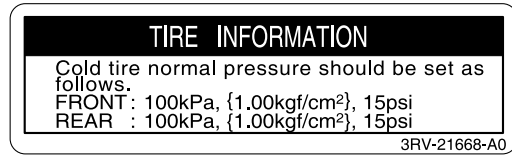



9



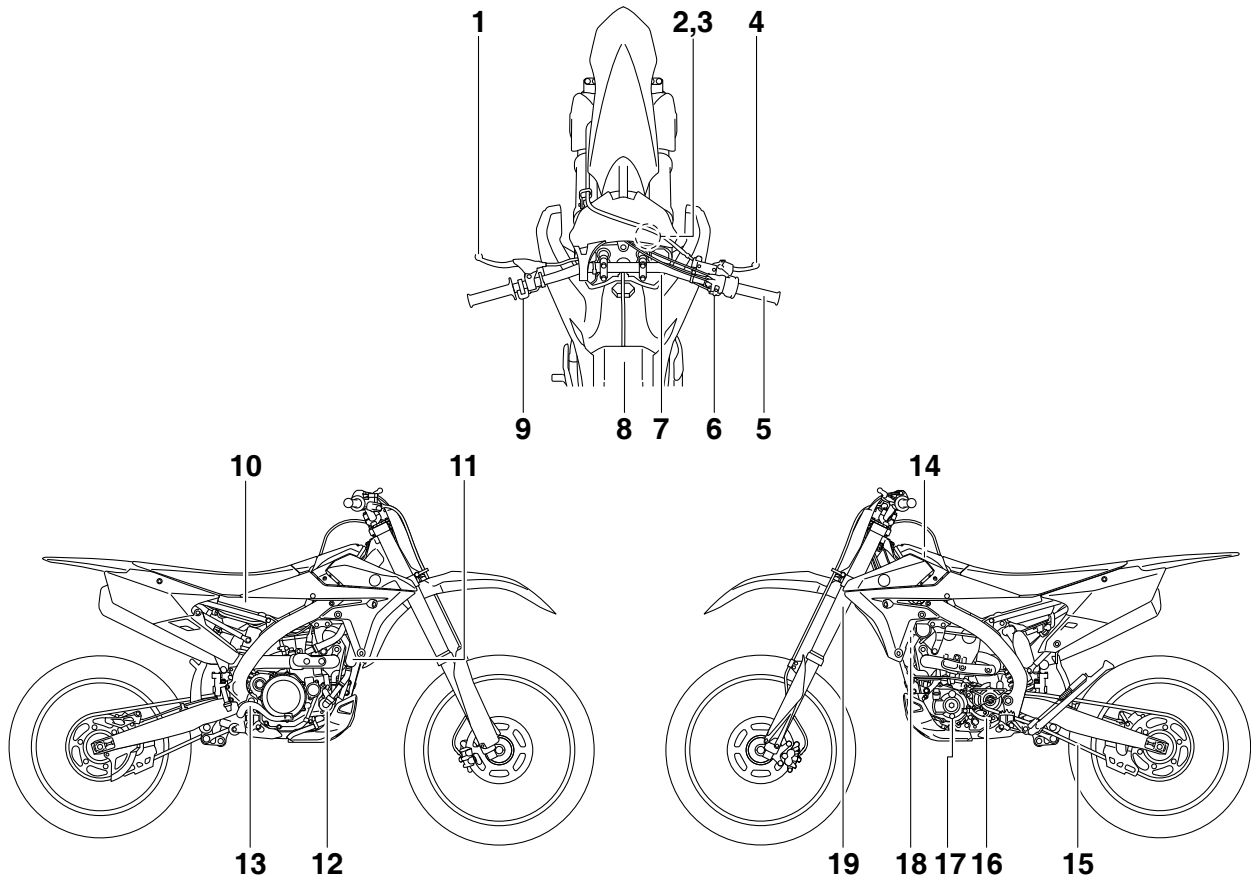

## DESCRIPTION



1. Clutch lever
2. Engine trouble warning light “”
3. Fuel level warning light “”
4. Front brake lever
5. Throttle grip
6. Start switch
7. Radiator cap
8. Fuel tank cap
9. Engine stop switch
10. Fuel tank

11. Radiator
12. Coolant drain bolt
13. Rear brake pedal
14. Air filter
15. Drive chain
16. Shift pedal
17. Oil level check window
18. Starter knob/idle screw
19. Front fork

### TIP

Designs and specifications of the vehicle are subject to change without notice. Therefore, please note that the descriptions in this manual may be different from those for the vehicle you have purchased.

## IDENTIFICATION

There are two significant reasons for knowing the serial number of your vehicle:

1. When ordering parts, you can give the number to your Yamaha dealer for positive identification of the model you own.
2. If your vehicle is stolen, the authorities will need the number to search for and identify your vehicle.

### VEHICLE IDENTIFICATION NUMBER

The vehicle identification number "1" is stamped into the right side of the frame.

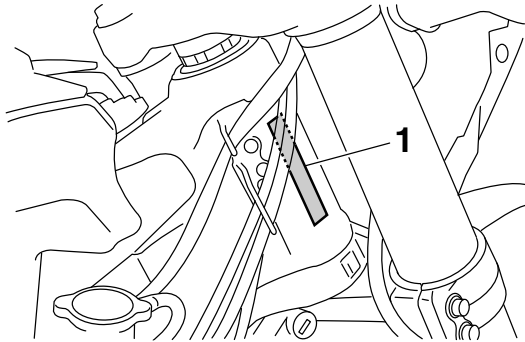

### ENGINE SERIAL NUMBER

The engine serial number "1" is stamped into the elevated part of the right-side of the engine.

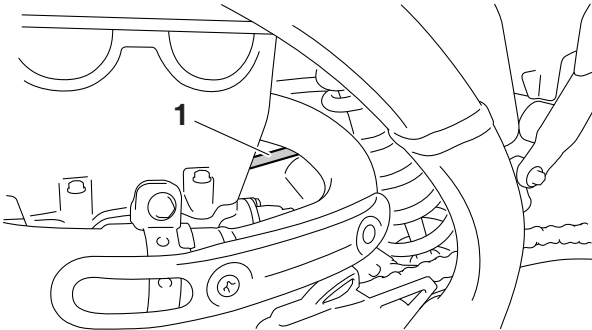

# INCLUDED PARTS

## INCLUDED PARTS

### SPARK PLUG WRENCH

The spark plug wrench "1" is used to remove or install the spark plug.

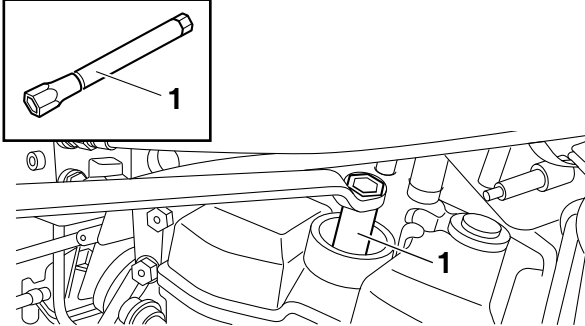

### NIPPLE WRENCH

The nipple wrench "1" is used to tighten the spoke.

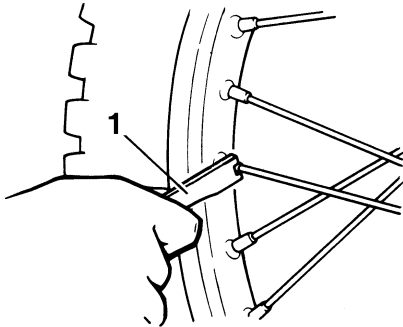

### HANDLEBAR PROTECTOR

Install the handlebar protector "1" with the mark "a" facing forward.

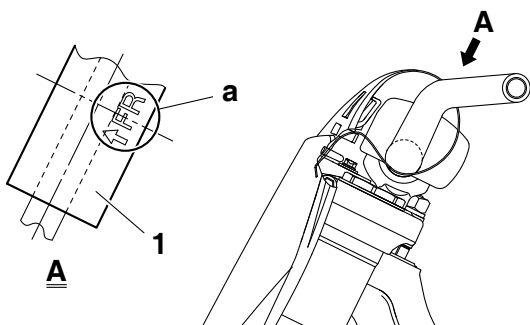

### FUEL HOSE JOINT COVER

The fuel hose joint covers "1" are used to prevent mud, dust, and other foreign materials from entering the inside when the fuel hose is disconnected.

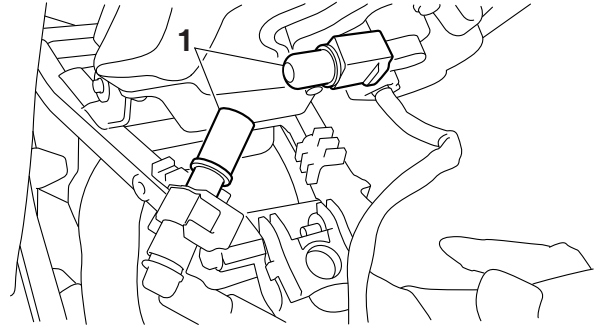

### COUPLER FOR CONNECTING OPTIONAL PART

The coupler "1" is used for connecting the optional Power Tuner and so on.

#### NOTICE

When no optional parts, etc. are connected, connect the connection terminal to the original coupler.

Before disconnecting the coupler, thoroughly wipe off any mud or water stuck to it.

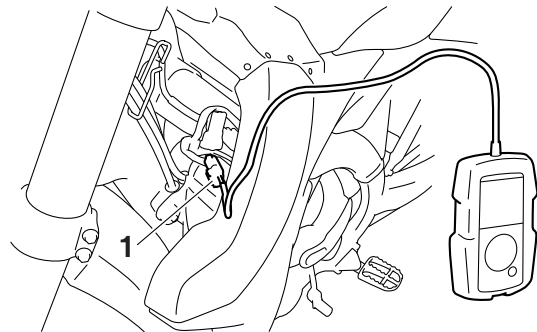

Part name	Part number
GYTR Power Tuner (For USA)	33D-H59C0-V2
YZ Power Tuner (Except for USA)	33D-859C0-11

The Power Tuner is an optional part.

## IMPORTANT INFORMATION

### PREPARATION FOR REMOVAL AND DIS-ASSEMBLY

1. Before the jobs, completely remove mud, dust, and the like in order to prevent the entry of them into the inside during the jobs.

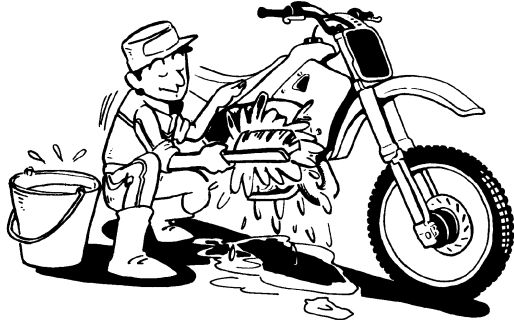

- Before cleaning with high-pressure water of washers, cover the following parts.  
Air duct  
Silencer exhaust port  
Drain hole on the cylinder head (right side)  
Hole under the water pump housing

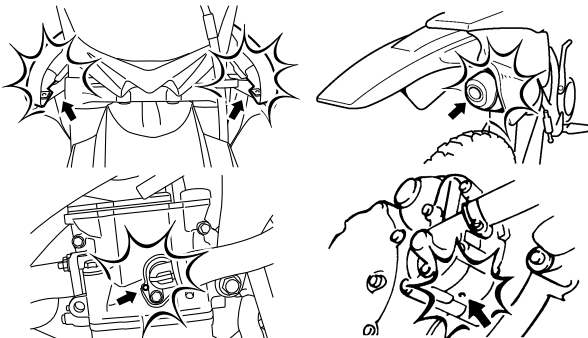

2. Use proper special tools and equipment. See "SPECIAL TOOLS".

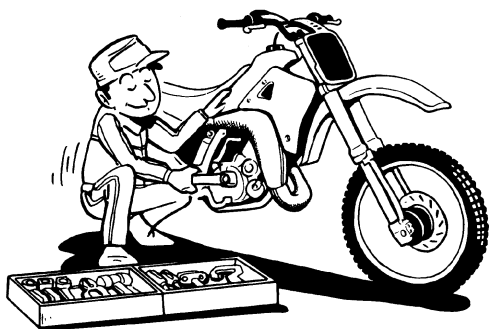

3. During disassembly, check and measure the required parts, and make a record of them so that you may refer to the record when installing them. Moreover, arrange gears, cylinders, pistons, and other parts for each section so as not to confuse or lose them.

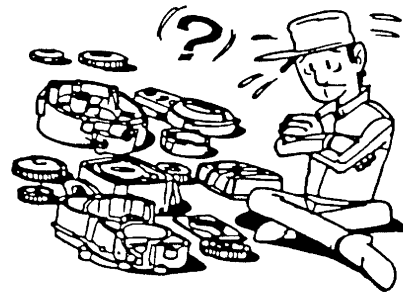

4. During disassembly, clean each of the parts, and store them in trays for each section.
5. Flammable. Keep servicing areas away from any source of fire.
6. During servicing, take special care not to receive an injury or a burn on the engine, the exhaust pipe, the silencer, or the like.
7. If coolant is left adhered to the chassis, paint and plating will be damaged. Therefore, rinse it out with water in good time.

### **⚠ WARNING**

**Coolant is potentially harmful and should be handled with special care.**

- If it enters your eyes, wash it away with water enough and then get medical attention
- If it splashes on your skin or clothes, quickly wash it away with water and then with soapy water.
- If it is swallowed, immediately induce vomiting and get medical attention.

### REPLACEMENT PARTS

Make sure that the parts and grease or oil to be used for repair of the vehicle, including periodic replacement parts, are new YAMAHA genuine parts and recommended parts.

Do not use any used parts, because these may not be genuine though they have similar appearances or because the quality may be changed by aging.

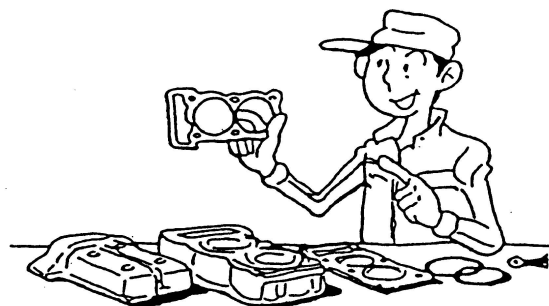

# IMPORTANT INFORMATION

## GASKETS, OIL SEALS AND O-RINGS

1. When overhauling the engine, replace all gaskets and O-rings. All gasket surfaces, oil seal lips, and O-rings must be cleaned so that there may be no dust on them.
2. During assembly, always apply proper oil to bearings and proper grease to oil seal lips before installation.

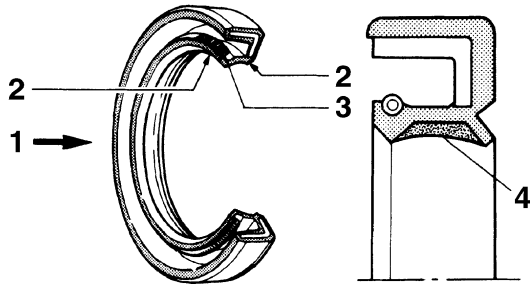

1. Oil
2. Lip
3. Spring
4. Grease

## LOCK WASHERS/PLATES AND COTTER PINS

After removal, replace lock washers/plates "1" and cotter pins with new ones. After the bolt or nut has been tightened to specification, firmly bend the lock tabs along a flat of the bolt or nut.

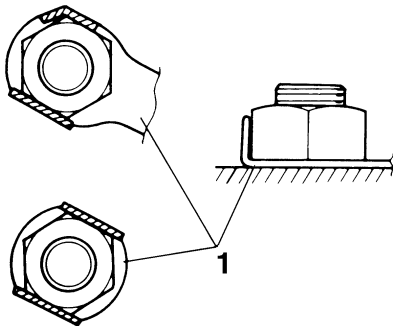

## BEARINGS AND OIL SEALS

Install bearings "1" and oil seals "2" with their manufacturer's marks or size symbols facing outward. During installation of an oil seal, make sure that its main lip faces the oil chamber (the target to be sealed). Before installation, always apply a light coat of grease to the oil seal lip.

### NOTICE

**Do not spin the bearing with compressed air because this will damage the bearing surfaces.**

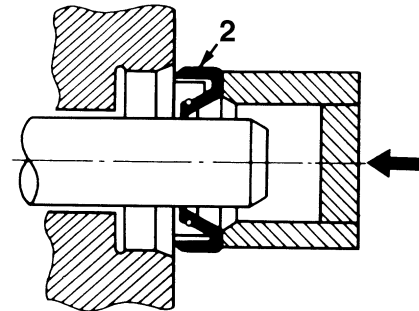
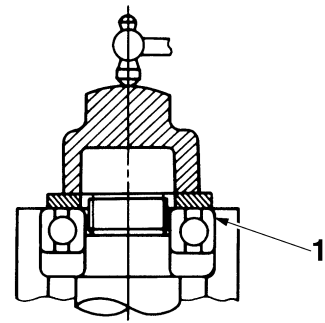

## CIRCLIPS

When assembling parts, always use new circlips. During installation of a circlip, make sure that the edge "2" of the circlip "1" is positioned opposite to the force "3" that the circlip receives. Install the circlip with its end aligned with the center of the spline, without opening the circlip more than necessary.

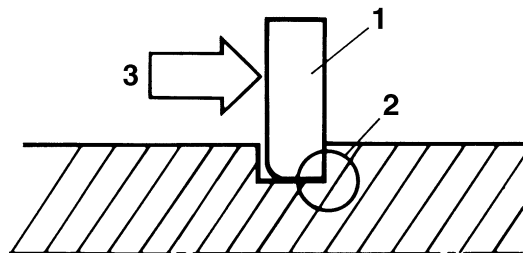

## BASIC SERVICE INFORMATION

### ELECTRICAL SYSTEM

#### Electrical parts handling

**NOTICE**

Never disconnect a battery lead while the engine is running; otherwise, the electrical components could be damaged.

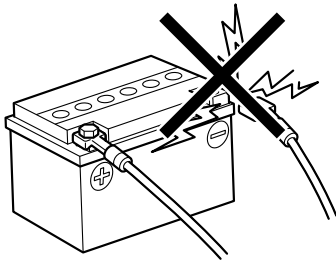
**NOTICE**

When disconnecting the battery leads from the battery, be sure to disconnect the negative battery lead first, then the positive battery lead. If the positive battery lead is disconnected first and a tool or similar item contacts the vehicle, a spark could be generated, which is extremely dangerous.

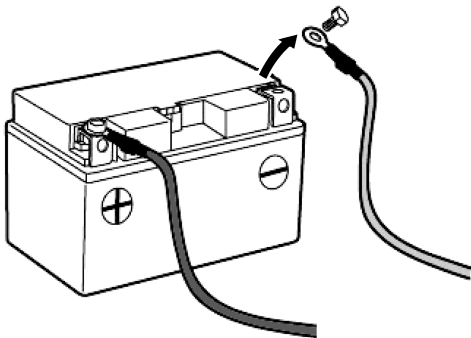
**TIP**

If a battery lead is difficult to disconnect due to rust on the battery terminal, remove the rust using hot water.

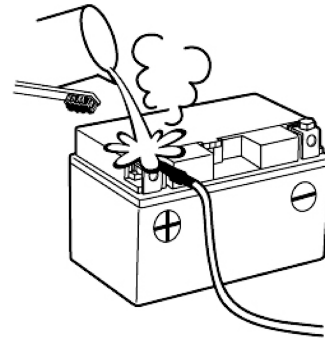
**NOTICE**

Be sure to connect the battery leads to the correct battery terminals. Reversing the battery lead connections could damage the electrical components.

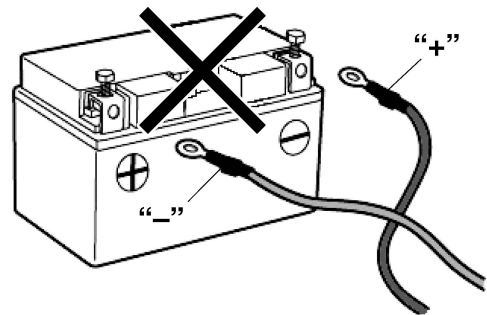
**NOTICE**

When connecting the battery leads to the battery, be sure to connect the positive battery lead first, then the negative battery lead. If the negative battery lead is connected first and a tool or similar item contacts the vehicle while the positive battery lead is being connected, a spark could be generated, which is extremely dangerous.

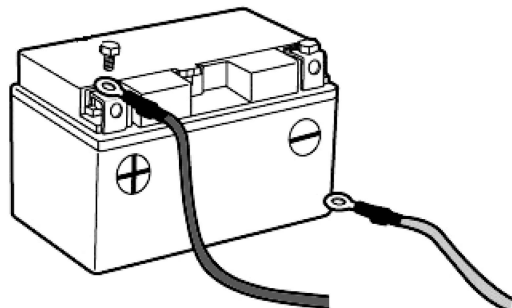
**NOTICE**

Make sure that the engine is stopped after pushing and holding the engine stop switch before disconnecting or connecting any electrical components.

## BASIC SERVICE INFORMATION

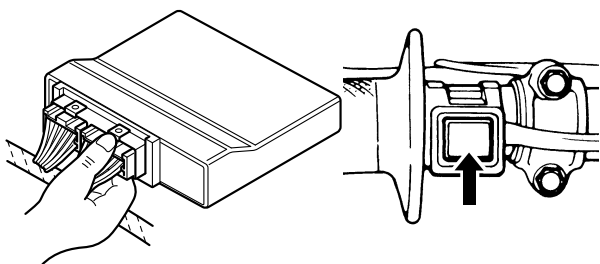

### NOTICE

Handle electrical components with special care, and do not subject them to strong shocks.

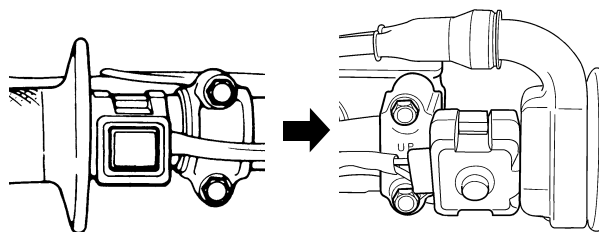

### Checking the electrical system

#### TIP

Before checking the electrical system, make sure that the battery voltage is at least 12 V.

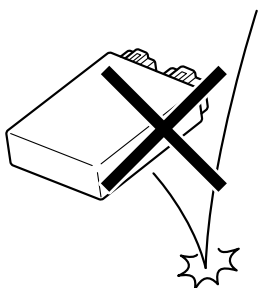

### NOTICE

Electrical components are very sensitive to and can be damaged by static electricity. Therefore, never touch the terminals and be sure to keep the contacts clean.

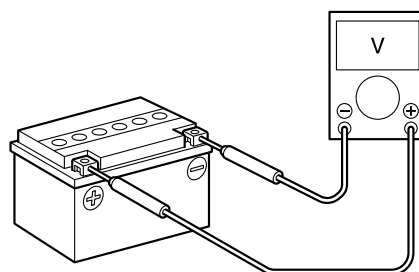

### NOTICE

Never insert the tester probes into the coupler terminal slots. Always insert the probes from the opposite end "a" of the coupler, taking care not to loosen or damage the leads.

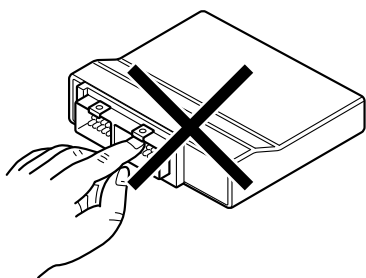

#### TIP

Push and hold the engine stop switch to turn off the engine when resetting the ECU (Electronic Control Unit). Disconnect the starter motor lead of the starter relay, and then push the starter switch. Be sure to wait for five seconds or longer before pushing the start switch after the engine is stopped.

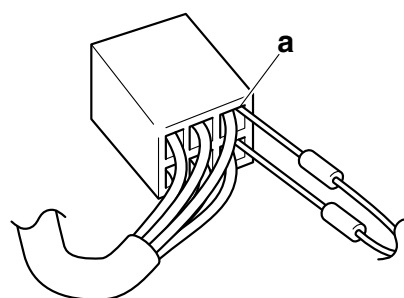

### NOTICE

For waterproof couplers, never insert the tester probes directly into the coupler. When performing any checks using a waterproof coupler, use the specified test harness or a suitable commercially available test harness.

# BASIC SERVICE INFORMATION

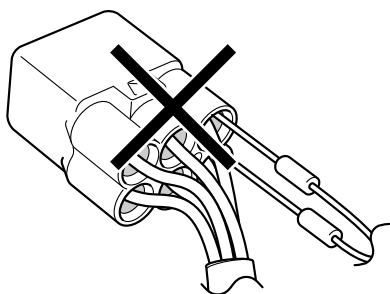

## Checking the connections

Check the leads, couplers, and connectors for stains, rust, moisture, etc.

### 1. Disconnect:

- Lead
- Coupler
- Connector

#### NOTICE

- When disconnecting a coupler, release the coupler lock, hold both sections of the coupler, and then disconnect the coupler.
- There are many types of coupler locks; therefore, be sure to check the type of coupler lock before disconnecting the coupler.

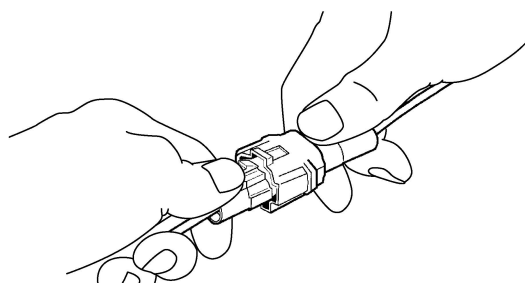

#### NOTICE

When disconnecting a connector, do not pull the leads. Hold both sections of the connector, and then disconnect the connector.

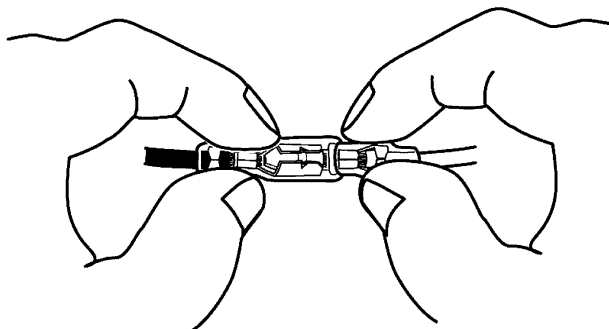

### 2. Check:

- Lead
- Coupler
- Connector

Moisture → Dry with compressed air.

Rust/stains → Connect and disconnect several times.

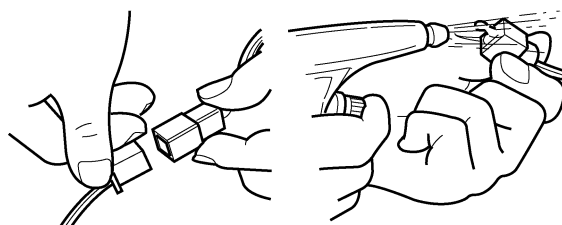

### 3. Check:

- All connections

Loose connection → Connect properly.

#### TIP

- If the pin "1" on the terminal is flattened, bend it up.
- After disassembling or assembling a coupler, pull on the leads to make sure that they are installed securely.

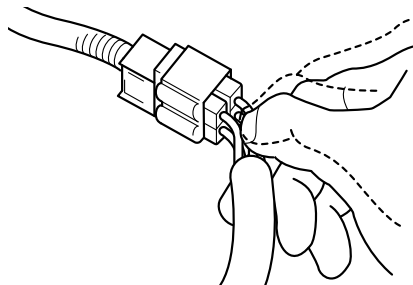
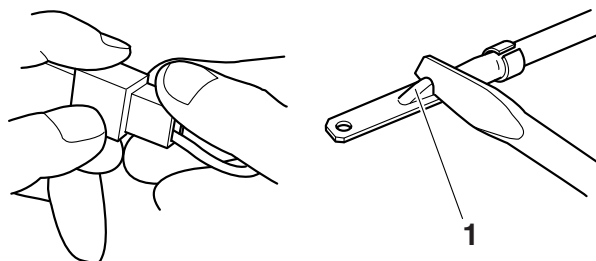



## BASIC SERVICE INFORMATION

### 4. Connect:

- Lead
- Coupler
- Connector

#### TIP

- When connecting a coupler or connector, make sure that both terminals are connected securely.
- Make sure all connections are tight.

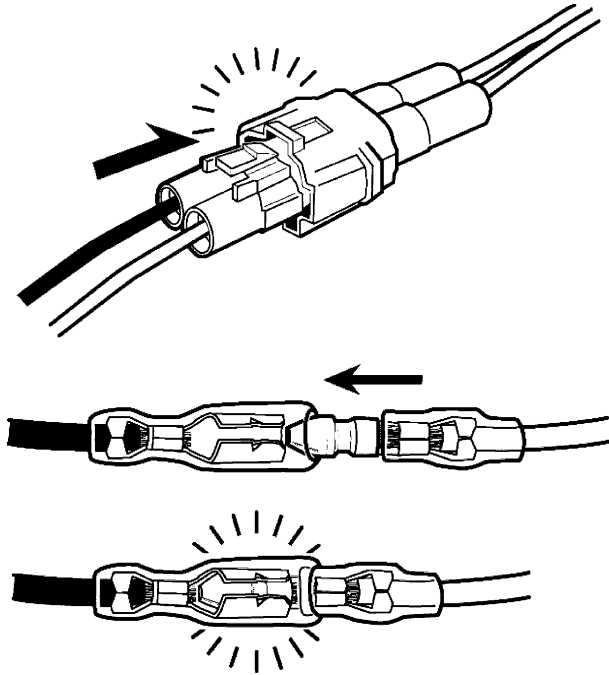
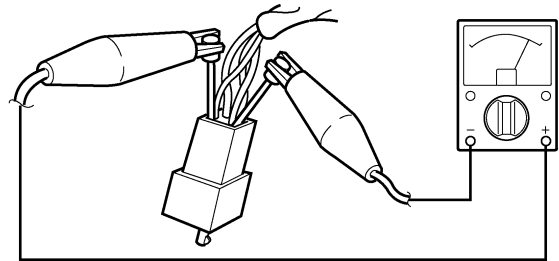
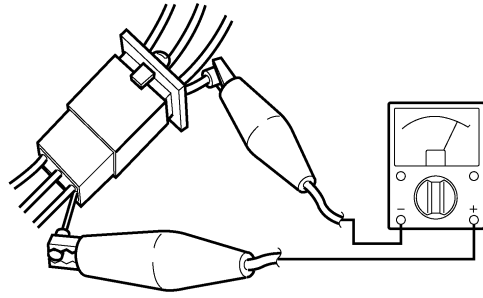

### 5. Check:

- No continuity

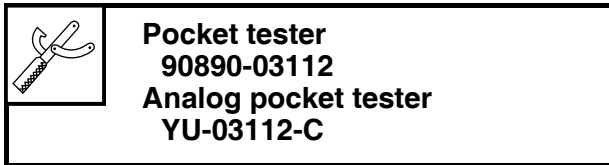

#### TIP

- If there is no continuity, clean the terminals.
- When checking the wire harness, perform steps (1) to (4).
- As a quick remedy, use a contact revitalizer available at most part stores.

## SPECIAL TOOLS



The following special tools are required for accurate and complete adjustment and assembly. Using the correct special tool will help prevent damage caused by the use of improper tools or improvised techniques. The shape and tool number used for the special tool differ by country, so two types are provided. Refer to the list provided to avoid errors when placing an order.

### TIP

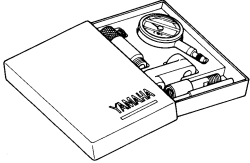
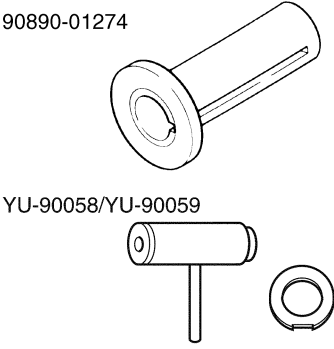
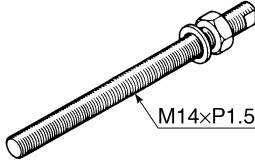
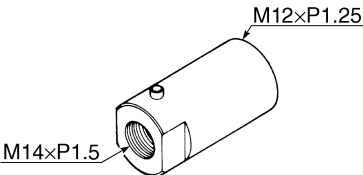
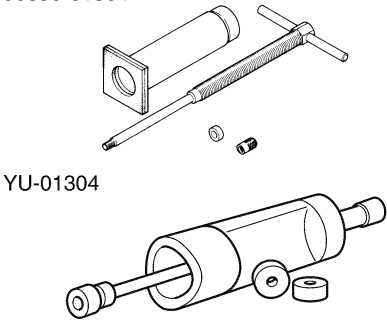

- For U.S.A. and Canada, use tool number starting with “YM-”, “YU-”, or “ACC-”.
- For others, use tool number starting with “90890-”.

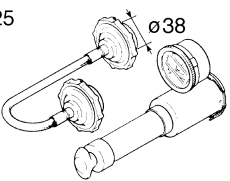
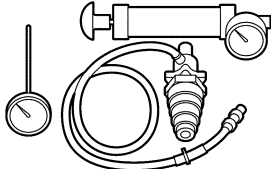
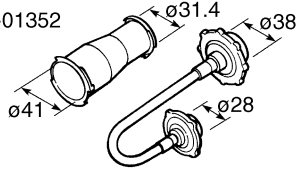
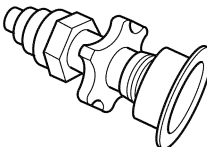
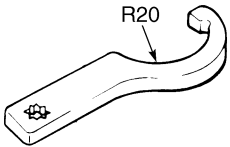
Tool name/Part number	How to use	Illustration
Dial gauge & stand set 90890-01252 Dial gauge set YU-03097-B	This tool is used to check parts for runout or bend.	
Crankshaft installer pot 90890-01274 Installing pot YU-90058	This tool is used to install the crankshaft.	90890-01274  YU-90058/YU-90059
Crankshaft installer bolt 90890-01275 Bolt YU-90060	This tool is used to install the crankshaft.	 M14xP1.5
Adapter (M12) 90890-01278 Adapter #3 YU-90063	This tool is used to install the crankshaft.	 M12xP1.25 M14xP1.5
Piston pin puller set 90890-01304 Piston pin puller YU-01304	This tool is used to remove the piston pin.	90890-01304  YU-01304

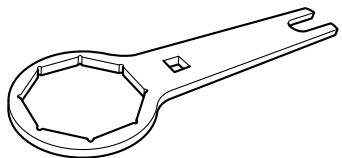
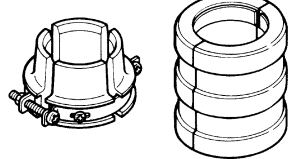
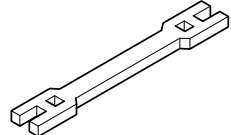
## SPECIAL TOOLS

Tool name/Part number	How to use	Illustration
Radiator cap tester 90890-01325 Mityvac cooling system tester kit YU-24460-A	This tool is used to check the radiator and the radiator cap.	90890-01325  $\phi 38$ YU-24460-A 
Radiator cap tester adapter 90890-01352 Pressure tester adapter YU-33984	This tool is used to check the radiator and the radiator cap.	90890-01352  $\phi 31.4$ $\phi 38$ $\phi 41$ $\phi 28$ YU-33984 
Steering nut wrench 90890-01403 Exhaust flange nut wrench YU-A9472	This tool is used to remove or tighten the steering nut.	 R20
Cap bolt wrench 90890-01500 Cap bolt wrench YM-01500	This tool is used to remove or tighten the base valve.	
Cap bolt ring wrench 90890-01501 Cap bolt ring wrench YM-01501	This tool is used to loosen or tighten the damper assembly.	
Fork seal driver 90890-01502 Fork seal driver (48) YM-A0948	This tool is used to install the oil seal of the front fork.	
Spoke nipple wrench (6-7) 90890-01521 Spoke nipple wrench (6-7) YM-01521	This tool is used to tighten the spoke.	

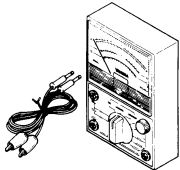
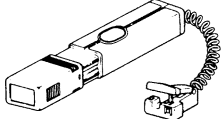
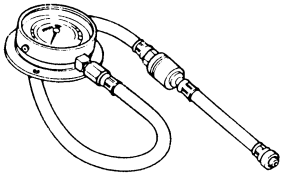
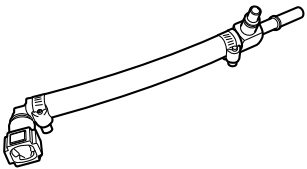
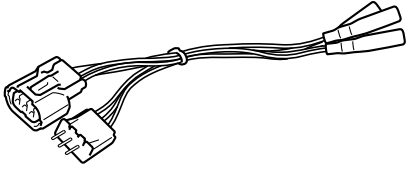
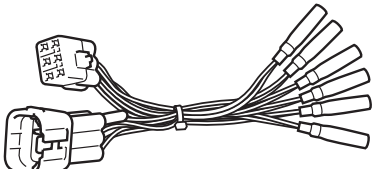
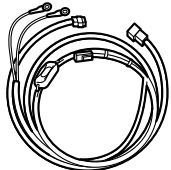
## SPECIAL TOOLS

Tool name/Part number	How to use	Illustration
Pocket tester 90890-03112 Analog pocket tester YU-03112-C	This tool is used to measure the voltage, current, and resistance of electrical components.	
Timing light 90890-03141 Timing light YU-03141	This tool is used to measure the ignition timing.	
Pressure gauge 90890-03153 Pressure gauge YU-03153	This tool is used to measure the fuel pressure.	
Fuel pressure adapter 90890-03186 Fuel pressure adapter YM-03186	This tool is used to mount the pressure gauge.	
Test harness S- pressure sensor (3P) 90890-03207 Test harness S- pressure sensor (3P) YU-03207	This tool is used to check the throttle position sensor input voltage.	
Test harness- lean angle sensor (6P) 90890-03209 Test harness- lean angle sensor (6P) YU-03209	This tool is used to check the lean angle sensor output voltage.	
FI diagnostic tool sub-lead 90890-03212 FI diagnostic tool sub-lead YU-03212	This tool is used to connect the Yamaha diagnostic tool to a battery.	
Yamaha diagnostic tool 90890-03231 Yamaha diagnostic tool (US) 90890-03234	This tool is used to check error codes or carry out self-diagnosis.	

# SPECIAL TOOLS

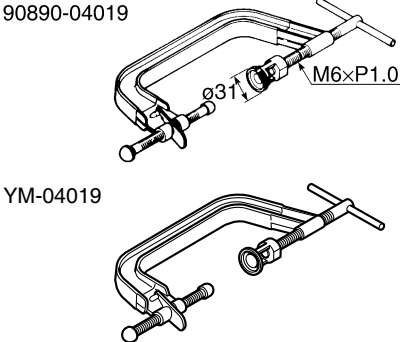
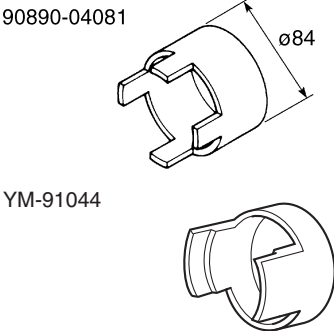
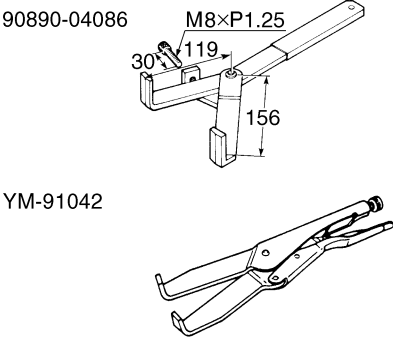
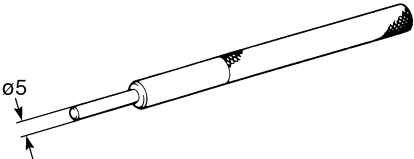
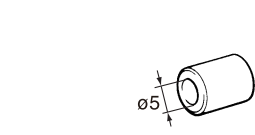
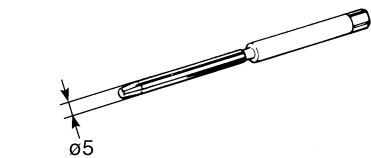
Tool name/Part number	How to use	Illustration
Valve spring compressor 90890-04019 Valve spring compressor YM-04019	This tool is used to disconnect or connect the valve and the valve spring.	
Spacer (crankshaft installer) 90890-04081 Pot spacer YM-91044	This tool is used to install the crankshaft.	
Universal clutch holder 90890-04086 Universal clutch holder YM-91042	This tool is used to hold the clutch when removing or installing the clutch boss securing nut.	
Valve guide remover (ø5) 90890-04097 Valve guide remover (5.0 mm) YM-04097	This tool is used to replace the valve guide.	
Valve guide installer (ø5) 90890-04098 Valve guide installer (5.0 mm) YM-04098	This tool is used to replace the valve guide.	
Valve guide reamer (ø5) 90890-04099 Valve guide reamer (5.0 mm) YM-04099	This tool is used to replace the valve guide.	

## SPECIAL TOOLS

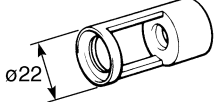
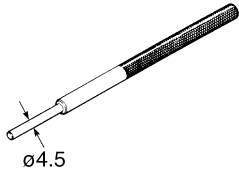
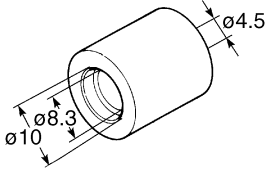
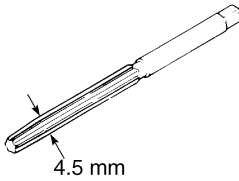
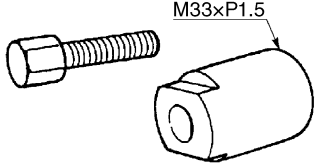
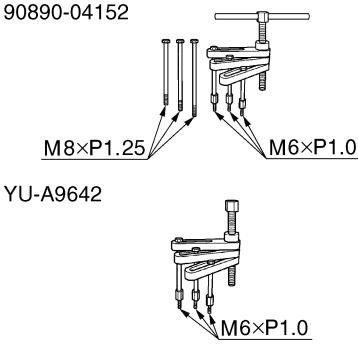
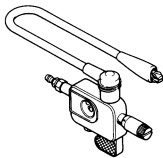
Tool name/Part number	How to use	Illustration
Valve lapper 90890-04101 Valve lapping tool YM-A8998	This tool is used to remove the valve lifter or lap the valve.	
Valve spring compressor attachment 90890-04108 Valve spring compressor adapter 22 mm YM-04108	This tool is used to disconnect or connect the valve and the valve spring.	
Valve guide remover (ø4.5) 90890-04116 Valve guide remover (4.5 mm) YM-04116	This tool is used to replace the valve guide.	
Valve guide installer (ø4.5) 90890-04117 Valve guide installer (4.5 mm) YM-04117	This tool is used to replace the valve guide.	
Valve guide reamer (ø4.5) 90890-04118 Valve guide reamer (4.5 mm) YM-04118	This tool is used to replace the valve guide.	
Rotor puller 90890-04142 Rotor puller YM-04142	This tool is used to remove the rotor.	
Crankcase separating tool 90890-04152 Crankcase separating tool YU-A9642	This tool is used to remove the crankshaft.	
Ignition checker 90890-06754 Oppama pet-4000 spark checker YM-34487	This tool is used to check the spark performance of the ignition coil.	

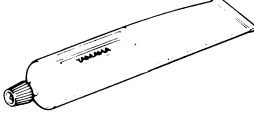

## SPECIAL TOOLS

Tool name/Part number	How to use	Illustration
Digital tachometer 90890-06760 Digital tachometer YU-39951-B	This tool is used to measure the engine speed.	
Yamaha bond No. 1215 90890-85505 (Three bond No.1215®)	This sealant (Bond) is used for crankcase mating surface, etc.	

## CONTROL FUNCTIONS

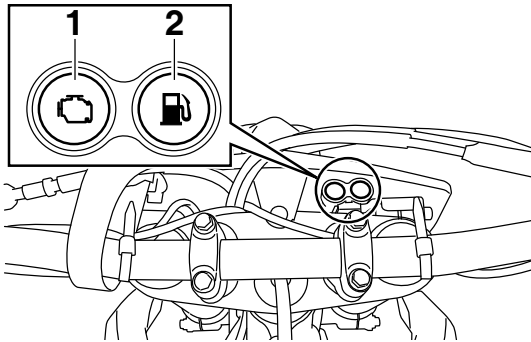
### WARNING LIGHTS



1. Engine trouble warning light “”
2. Fuel level warning light “”

#### Engine trouble warning light “”

This warning light comes on or flashes if a problem is detected in the electrical circuit monitoring the engine. If this occurs, have a Yamaha dealer check the vehicle.

The electrical circuit of the warning light can be checked by pushing the start switch. The warning light should come on for a few seconds, and then go off.

If the warning light does not come on initially when the start switch is pushed, or if the warning light remains on, have a Yamaha dealer check the electrical circuit.

#### Fuel level warning light “”

This warning light comes on when the fuel level drops below approximately 2.1 L (0.55 US gal, 0.46 Imp.gal). When this occurs, refuel as soon as possible.

The electrical circuit of the warning light can be checked by pushing the start switch. The warning light should come on for a few seconds, and then go off.

If the warning light does not come on initially when the start switch is pushed, or if the warning light remains on, have a Yamaha dealer check the electrical circuit.

### ENGINE STOP SWITCH

The engine stop switch “1” is located on the left handlebar. Continue pushing the engine stop switch till the engine comes to a stop.

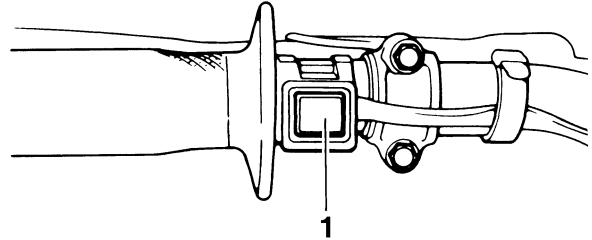

### START SWITCH

The start switch “1” is located on the right handlebar. Push this switch to crank the engine with the starter.

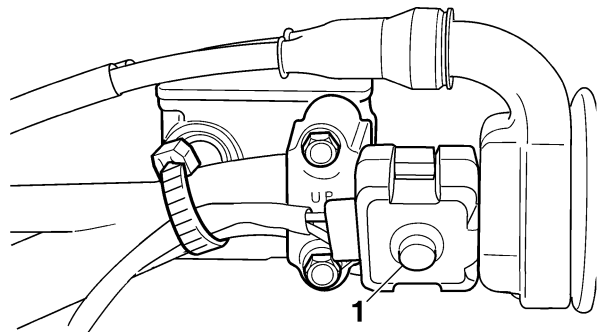

### CLUTCH LEVER

The clutch lever “1” is located on the left handlebar. The clutch lever disengages or engages the clutch.

Pull the clutch lever toward the handlebar to disengage the clutch, and release the lever to engage the clutch.

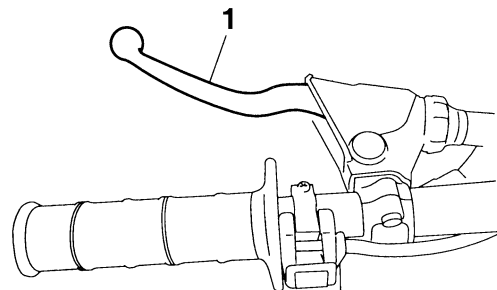



# CONTROL FUNCTIONS

## SHIFT PEDAL

The shift pedal "1" has adopted a method of 1 down & 5 ups (press-down & kick-ups). Press it down for N (neutral) to 1st, and kick it up for 2nd to 6th.

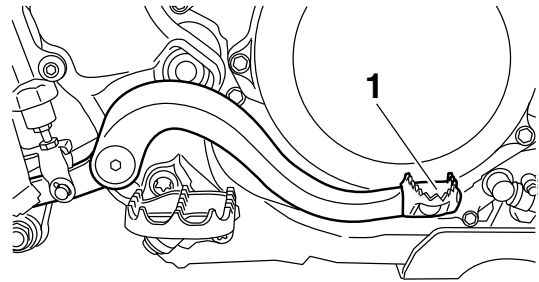
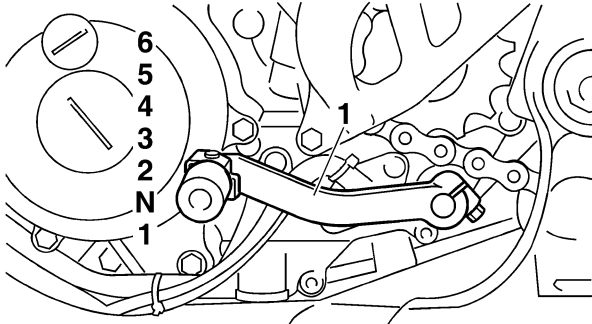

## SIDESTAND

This sidestand "1" is used to support only the machine when standing or transporting it.

### ⚠ WARNING

- Never apply additional force to the sidestand.
- Hold up the sidestand before starting out.

## THROTTLE GRIP

The throttle grip "1" is located on the right handlebar. The throttle grip accelerates or decelerates the engine. For acceleration, turn the grip toward you; for deceleration, turn it away from you.

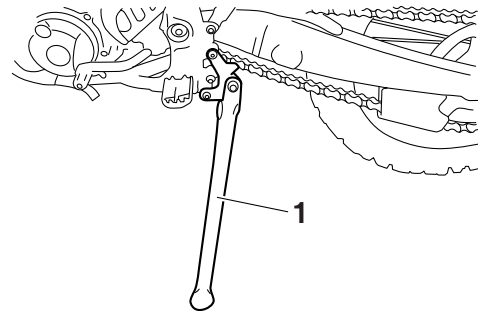
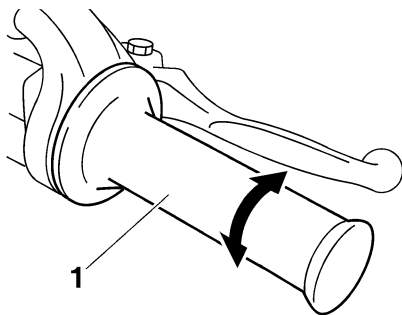

## FRONT BRAKE LEVER

The front brake lever "1" is located on the right handlebar. Pull it toward the handlebar to activate the front brake.

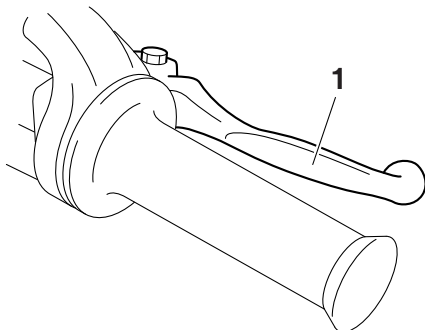

## STARTER KNOB/IDLE ADJUSTING SCREW

Starting a cold engine requires a larger amount of intake air, which is supplied by the starter knob/idle screw "1".

Pulling the knob toward "a" turns ON the starter, resulting in a larger amount of intake air. Pushing the knob toward "b" turns OFF the starter.

### ⚠ WARNING

While handling the starter knob/idle screw, take care not to burn yourself on exhaust pipes.

## REAR BRAKE PEDAL

The rear brake pedal "1" is in the right of the chassis. Press down on the brake pedal to activate the rear brake.

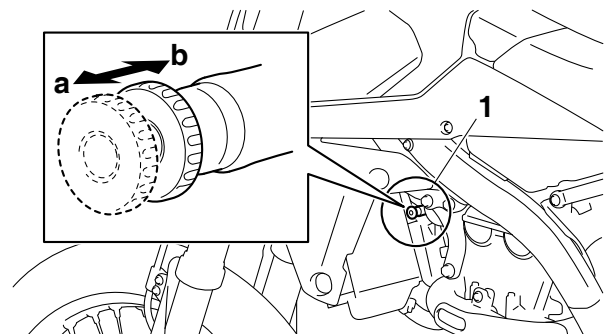

## FUEL TANK CAP

Fuel tank cap “1” is located under the fuel tank cap cover “2”.

Remove the fuel tank cap cover to open the fuel tank cap.

### TIP

- To remove the fuel tank cap cover, insert fingers under part “a”, and then use both hands to lift it up towards the rear of the vehicle.
- Install the fuel tank cap cover after placing the bands “3” all the way in under the seat.

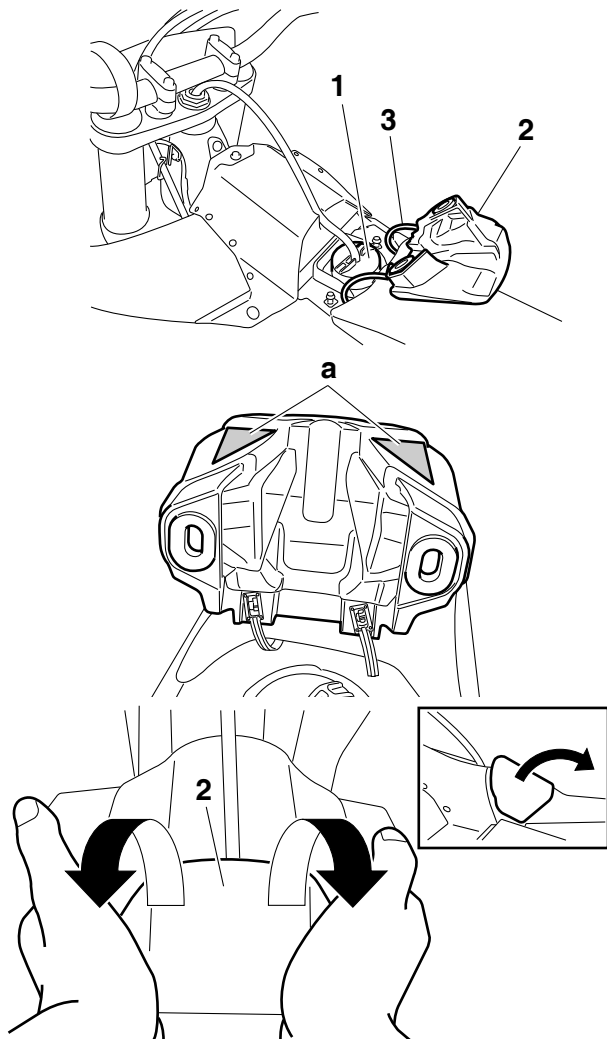

## STARTING AND BREAK-IN

### FUEL

Always use the recommended fuel as stated below. Also, be sure to use new gasoline the day of a race.



**Recommended fuel**  
**Premium unleaded gasoline**  
**Fuel tank capacity**  
7.5 L (2.0 US gal, 1.7 Imp.gal)  
**Fuel reserve amount**  
2.1 L (0.55 US gal, 0.46 Imp.gal)

### NOTICE

**Use only unleaded gasoline. The use of leaded gasoline will cause severe damage to the engine internal parts such as valves, piston rings, and exhaust system, etc.**

### TIP

Your Yamaha engine has been designed to use premium unleaded gasoline with a pump octane number  $[(R+M)/2]$  of 91 or higher, or a research octane number of 95 or higher. If knocking (or pinging) occurs, use a gasoline of a different brand.

### WARNING

- **For refueling, be sure to stop the engine and use enough care not to spill any fuel. Also be sure to avoid refueling close to a fire.**
- **Refuel after the engine, exhaust pipe, etc. have cooled off.**

### Gasohol (For USA and Canada)

There are two types of gasohol: gasohol containing ethanol and that containing methanol. Gasohol containing ethanol can be used if the ethanol content does not exceed 10 %. Gasohol containing methanol is not recommended by Yamaha because it can cause damage to the fuel system or vehicle performance problems.

### HANDLING NOTE

### WARNING

**Never start or run the engine in a closed area. The exhaust fumes are poisonous; they can cause loss of consciousness and death in a very short time. Always operate the machine in a well-ventilated area.**

### NOTICE

- **If the throttle is open the air/ fuel mixture may be too lean for the engine to start.**
- **Before starting the machine, perform the checks in the pre-operation check list.**

### AIR FILTER MAINTENANCE

According to "CLEANING THE AIR FILTER ELEMENT" section in the CHAPTER 3, apply the Yamaha foam air filter oil or other quality foam air filter oil to the element. (Excess oil in the element may adversely affect engine starting.)

### STARTING A COLD ENGINE

### NOTICE

**For maximum engine life, never accelerate hard when the engine is cold!**

In order for the ignition circuit cut-off system to enable starting, one of the following conditions must be met:

- The transmission is in the neutral position.
  - The transmission is in gear with the clutch lever pulled.
1. Pull the starter knob/idle screw "1" to its full length.

### TIP

When the ambient temperature is 15 °C (59 °F) or below, use the starter knob/idle screw.

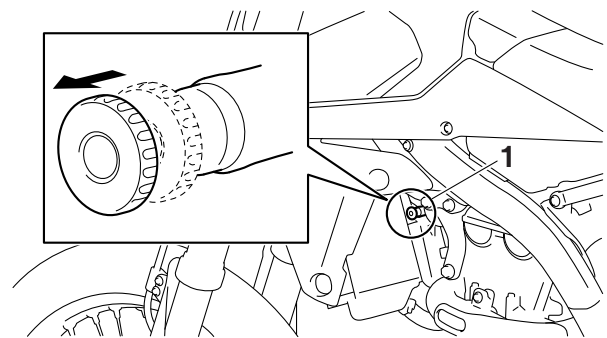

2. Completely close the throttle.
3. Start the engine by pushing the start switch. If the engine fails to start when using the start switch, release it, wait a few seconds, and then try again. Each starting attempt should be as short as possible to preserve the battery. Do not crank the engine more than 10 seconds on any one attempt.

# STARTING AND BREAK-IN

## NOTICE

If the starter motor will not turn when the start switch is pushed, stop pushing it immediately in order to avoid placing extra load on the starter motor.

## TIP

If the engine fail to start, fully open the throttle grip and push the start switch few seconds to clear the engine of the rich air-fuel mixture retained in it.

4. When the engine starts running, warm this up one or two minutes at a steady speed (of 3000 to 5000 r/min), and then return the starter knob/idle screw to its original position.

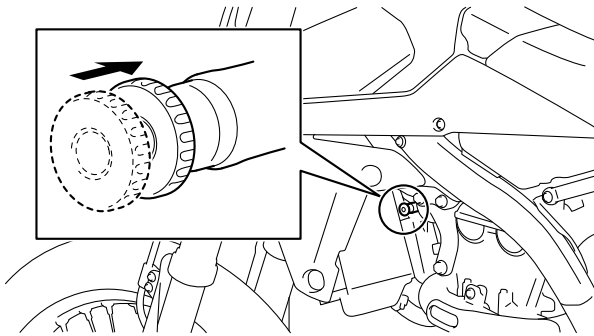

## WARNING

Since exhaust gas contains harmful ingredients, do not start or warm it up at an ill-ventilated place or a closed narrow place.

5. To stop the engine, push the engine stop switch "1".

## TIP

Continue pushing the engine stop switch till the engine comes to a full stop.

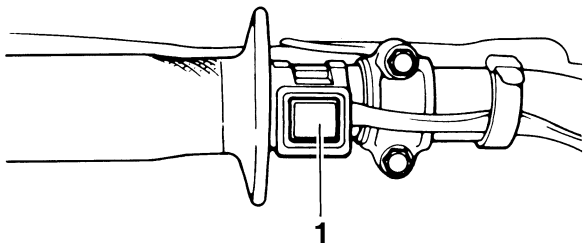

## STARTING A WARM ENGINE

Follow the same procedure as for starting a cold engine with the exception that the starter is not required when the engine is warm.

## TIP

If the engine fail to start, fully open the throttle grip and push the start switch few seconds to clear the engine of the rich air-fuel mixtare retained in it.

## BREAK-IN PROCEDURES

A break-in is important so that rotating portion, sliding surfaces, and mounted areas may fit one another, and that the rider may become accustomed to the machine.

## NOTICE

Before running, do maintenance on the air filter element.

Refer to "CLEANING THE AIR FILTER ELEMENT" on page 3-12.

1. After warming up the engine, drive it for about 20 minutes at a throttle opening of 1/2 or less.
2. Make a pit stop, and check mounted areas for looseness, oil leaks, or other problems.
3. Then, drive it for about 40 minutes at a throttle opening of 3/4 or less.
4. Make a pit stop again, and thoroughly check mounted areas for looseness, oil leaks, or other problems. Thorough checks and adjustments are required in particular for stretch of cables, free play of the brake, stretch of the drive chain, looseness of the spoke, and so on.

## NOTICE

After a break-in or after each race, always check the points shown in "TORQUE-CHECK POINTS" for tightening torques and retighten them. (Refer to "TORQUE-CHECK POINTS" on page 1-25.)

Also when the following parts are replaced, a break-in is required.

- Cylinder and Crankshaft: A break-in is required for about an hour.
  - Piston, Piston ring, Valve, Camshaft, and Gear: A break-in is required for about 30 minutes at a throttle opening of 1/2 or less.
- Observe the condition of the engine carefully during a break-in.

For checkpoints for a break-in, see "MAINTENANCE AFTER BREAK-IN". If any problem is found, immediately stop the engine and make a checkup.

## MAINTENANCE AFTER BREAK-IN

After a break-in, perform careful maintenance to get ready for the next practice or race. Refer to “PRE-OPERATION INSPECTION AND MAINTENANCE” on page 3-7.

### MAJOR MAINTENANCE

#### 1. For the engine

- Leaks around the engine  
Check for pressure leaks from the cylinder head or the cylinder, oil leaks from the crankcase or the case cover, leaks from the coolant system, and other leaks.
- Check that the valve, the cylinder head, the cylinder, the piston, and the piston ring fit one another, and that contact between the valve and the cylinder head, and that between the cylinder and the piston are correct.
- Engine oil change  
Drain the oil, and check for dirt and foreign materials such as metal chips. (If any foreign material is mixed, disassemble and check the crankcase.)  
Pour the specified amount of the recommended oil.
- AC magneto  
Check for looseness in mounted areas of the rotor and the stator.  
Check that the connector is not being disconnected.
- Silencer  
Check the main body and stay for cracks.  
Check for leaks.
- Mounting bolts and nuts  
Check for looseness in mounted areas of parts, as well as engine mounting bolts and engine brackets.

#### 2. For the chassis

- Check welds and mounted areas of the frame, the swingarm, the link, the bracket, and so on, for looseness and cracks.
- Wheel (s)  
Check the wheel for runout. Check the spoke for looseness.
- Brake(s)  
Check the brake disc mounting bolt for looseness.  
Check that the reservoir contains the specified amount of brake fluid. Check for leaks.

- Cable  
Grease and adjust cables.
- Drive chain  
Lubricate the drive chain and adjust its tension.
- Fuel tank  
Clean the inside of the fuel tank. Check for leaks.
- Suspension  
Check for oil leaks in the front fork or the rear shock absorber. Check that the mounted conditions are good.
- Sprocket  
Check for looseness in the sprocket mounted on the rear wheel.
- Mounting bolts and nuts  
Check mounted areas for looseness.

---

### NOTICE

**After a break-in or before each race, always check the points shown in “TORQUE-CHECK POINTS” for tightening torques and retighten them. (Refer to “TORQUE-CHECK POINTS” on page 1-25.)**

---

- Greasing and oiling  
Always grease or oil the specified points.

# TORQUE-CHECK POINTS

## TORQUE-CHECK POINTS

Frame construction		Frame to rear frame		
		Frame to engine protector		
		Combined seat and fuel tank	Fuel tank to frame	
Engine mounting		Frame to engine		
		Engine bracket to engine		
		Engine bracket to frame		
Seat		Seat to frame		
Steering		Steering stem to handlebar		
		Steering stem to frame		
		Steering stem to upper bracket		
		Upper bracket to handlebar		
Suspension	Front	Steering stem to front fork		
		Front fork to upper bracket		
			Front fork to lower bracket	
	Rear	Link		
		Assembly of links		
		Link to frame		
		Link to rear shock absorber		
Link to swingarm				
Mounting of rear shock absorber		Rear shock absorber and frame		
Mounting of swingarm		Tightening of pivot shaft		
Wheel (s)		Mounting of wheel		
		Front	Tightening of wheel axle	
			Tightening of axle holder	
			Tightening of spoke nipple	
		Rear	Tightening of wheel axle	
			Wheel to rear wheel sprocket	
Tightening of spoke nipple				
Brake(s)		Front	Brake caliper to front fork	
			Brake disc to wheel	
			Tightening of union bolt	
			Brake master cylinder to handlebar	
			Tightening of bleed screw	
			Tightening of brake hose holder	
		Rear	Brake pedal to frame	
			Brake disc to wheel	
			Tightening of union bolt	
			Brake master cylinder to frame	
			Tightening of bleed screw	
			Tightening of brake hose holder	
Shift pedal		Shift pedal to shift shaft		
Fuel system		Fuel pump to fuel tank		
		Fuel sender to fuel tank		

Thank you so much for reading.  
Please click the “Buy Now!”  
button below to download the  
complete manual.



After you pay.

You can download the most  
perfect and complete manual in  
the world immediately.

Our support email:

[ebooklibonline@outlook.com](mailto:ebooklibonline@outlook.com)