

# ***Workshop Manual for 9380 DELTA Combine Series***

*MF 9380 DELTA + Auto Level*



# Workshop Manual for 9380 DELTA Combine Series

<b>1</b>	<b>Introduction - Specifications</b>	13
1.1	<b>Using the manual</b>	15
1.1.1	Using the manual	15
1.2	<b>General specifications</b>	16
1.2.1	Dimensions and specifications	16
1.2.2	Specification table for tyres with equipment	25
1.3	<b>Safety precautions</b>	28
1.3.1	Safety precautions	28
1.3.2	Safety in the workshop	28
1.3.3	Safety - a word to the mechanic	28
1.3.4	Safety - danger, warning and caution	28
1.3.5	Safety decals	29
1.3.6	General	29
1.3.7	Personal safety	29
1.3.8	Considerations with regard to equipment	30
1.3.9	General considerations	31
1.3.10	Operational considerations	31
1.3.11	Maintenance techniques	32
1.4	<b>Practical advice</b>	34
1.4.1	Practical advice	34
1.5	<b>Start-up instructions</b>	38
1.5.1	General	38
1.5.2	Pre-delivery checks	38
1.5.3	Instruction of combine operator	40
1.6	<b>Conversion tables</b>	43
1.6.1	Conventional units of measurement	43
1.7	<b>Locking and sealing agents</b>	44
1.7.1	Locking and sealing agents	44
1.8	<b>Wheel nut torques</b>	45
1.8.1	Wheels	45
1.8.2	Bolts with metric threads	45
1.8.3	Nuts with metric threads	46
<b>2</b>	<b>Cutting table</b>	47
2.1	<b>General</b>	49
2.1.1	Table, general	49
2.2	<b>Knife drive - wobble box 18-30 ft</b>	50
2.2.1	Removal	50
2.2.2	Assembly	50
2.2.3	Reconditioning the wobble box	51
2.2.4	Positioning the double fingers, knife and crop lifters	57
2.3	<b>Table auger, 18-30 ft</b>	58
2.3.1	Removal	58
2.3.2	Assembly	59
2.3.3	Replacing the shaft on the left-hand side	59
2.3.4	Replacing the shaft on the right-hand side	59
2.3.5	Replacing the crankshaft	60
2.3.6	Replacing the feathering fingers, bearings and bushes	61
2.3.7	Adjusting the table auger and feathering fingers	62
2.4	<b>Table body, 18-30 ft</b>	64
2.4.1	Adjusting the cut-off strips	64
2.4.2	Adjusting and positioning the ground sensor - PowerFlow	65

<b>2.5</b>	<b>Table body, 35 ft</b> .....	67
2.5.1	Adjusting the ground sensor - 35' PowerFlow .....	67
<b>2.6</b>	<b>Friction clutch and chain drive 18-30 ft</b> .....	69
2.6.1	Removing the friction coupling .....	69
2.6.2	Assembly .....	69
2.6.3	Replacing the bearings and sprockets .....	70
<b>2.7</b>	<b>Countershaft, 18-30 ft.</b> .....	71
2.7.1	Removing the countershaft .....	71
2.7.2	Fitting the countershaft .....	72
<b>2.8</b>	<b>PowerFlow belts, 18-30 ft.</b> .....	73
2.8.1	PowerFlow belts .....	73
2.8.2	Removal, belts .....	73
2.8.3	Assembly, belts .....	76
2.8.4	Replacing the front rollers and bearings, scraper adjustment .....	77
2.8.5	Replacing the rear rollers and bearings, scraper adjustment .....	79
2.8.6	Replacing and aligning the bearing housing, rear rollers .....	80
2.8.7	Belt tensioning and running-in .....	81
<b>3</b>	<b>Reel</b> .....	85
<b>3.1</b>	<b>Reel, 18-30 ft.</b> .....	87
3.1.1	Removal .....	87
3.1.2	Assembly .....	88
3.1.3	Replacing the reel tine bar and plastic bearings .....	89
3.1.4	Replacing the guide rollers, eccentric, guide ring and bearings .....	90
3.1.5	Replacing the reel plates .....	91
3.1.6	Replacing the reel tube, bearings .....	91
<b>3.2</b>	<b>Oil motor and chain drive, 18-30 ft</b> .....	92
3.2.1	Replacing the oil motor .....	92
3.2.2	Replacing the flow divider .....	92
<b>3.3</b>	<b>Hydraulic cylinders, 18-30 ft.</b> .....	93
3.3.1	Replacing the cylinder – reel up/down .....	93
3.3.2	Replacing the cylinder – reel forward/back .....	94
3.3.3	Reconditioning of hydraulic cylinders .....	94
<b>3.4</b>	<b>Oil motor and chain drive, 35 ft</b> .....	97
3.4.1	Replacement of oil motor, 35 ft .....	97
3.4.2	Replacing the flow divider .....	97
<b>3.5</b>	<b>Hydraulic cylinders, 35 ft</b> .....	98
3.5.1	Replacing the cylinder – reel forward/back .....	98
<b>4</b>	<b>Main crop elevator</b> .....	99
<b>4.1</b>	<b>General</b> .....	101
4.1.1	Main crop elevator, general .....	101
<b>4.2</b>	<b>Main crop elevator.</b> .....	102
4.2.1	Removal of Crop Elevator .....	102
4.2.2	Fitting the crop elevator .....	103
4.2.3	Bearing block on machine frame .....	104
4.2.4	Replacing the lifting ram .....	104
4.2.5	Reconditioning the hydraulic cylinder .....	105
4.2.6	Replacing the cutting height preset sensor .....	106
<b>4.3</b>	<b>Crop elevator chain</b> .....	107
4.3.1	Crop elevator chain, general .....	107
4.3.2	Removing the crop elevator chain .....	107
4.3.3	Fitting the crop elevator chain .....	108
4.3.4	Replacement of slats .....	109
4.3.5	Replacing the slide rails in the crop elevator .....	109
4.3.6	Replacing the intermediate plate .....	110
<b>4.4</b>	<b>Elevator chain top shaft.</b> .....	111
4.4.1	Removing the elevator chain top shaft .....	111
4.4.2	Fitting the elevator chain top shaft .....	112
4.4.3	Replacing the bearings .....	112
4.4.4	Replacing the sprockets and centre bearing .....	114
4.4.5	Replacing the shaft protection tube .....	117

<b>4.5</b>	<b>Elevator chain front shaft</b> .....	118
4.5.1	Removing the elevator chain front shaft .....	118
4.5.2	Fitting the elevator chain front shaft .....	119
4.5.3	Replacing the shaft bearings .....	120
<b>4.6</b>	<b>Elevator countershaft</b> .....	121
4.6.1	Removing the elevator intermediate shaft .....	121
4.6.2	Fitting elevator intermediate shaft .....	122
<b>4.7</b>	<b>Friction clutch and belt drive</b> .....	123
4.7.1	Removal of friction clutch .....	123
4.7.2	Fitting the friction clutch .....	123
4.7.3	Reconditioning of the friction clutch .....	124
<b>4.8</b>	<b>Adapter</b> .....	125
4.8.1	Removal of adapter .....	125
4.8.2	Fitting the adapter .....	126
4.8.3	Replacing the levelling cylinder .....	126
4.8.4	Reconditioning the hydraulic cylinder .....	126
4.8.5	Replacing the angle sensor .....	127
<b>4.9</b>	<b>Hydraulic reversing</b> .....	128
4.9.1	Removal of hydraulics motor .....	128
4.9.2	Removing the hydraulic cylinder .....	129
<b>5</b>	<b>Threshing unit</b> .....	131
<b>5.1</b>	<b>General</b> .....	133
5.1.1	Threshing unit, general .....	133
<b>5.2</b>	<b>Stone trap</b> .....	134
5.2.1	Removal .....	134
5.2.2	Assembly .....	135
<b>5.3</b>	<b>Concave</b> .....	136
5.3.1	Removing the concave .....	136
5.3.2	Fitting the concave .....	137
5.3.3	Adjusting the concave laterally .....	137
5.3.4	Concave setting - initial setting .....	138
5.3.5	Replacing the lead-in plate .....	139
5.3.6	Replacing the shaft for concave setting .....	139
<b>5.4</b>	<b>Threshing cylinder</b> .....	141
5.4.1	Removing the threshing cylinder .....	141
5.4.2	Fitting the threshing cylinder .....	142
5.4.3	Replacing the bearings .....	143
5.4.4	Replacing the rasp bars and backing bars .....	144
5.4.5	Replacing the shaft and cylinder spiders .....	144
<b>5.5</b>	<b>Cylinder variator – table clutch</b> .....	146
5.5.1	Removal, hydraulic variator .....	146
5.5.2	Assembly, hydraulic variator .....	147
5.5.3	Reconditioning the hydraulic variator pulley .....	147
5.5.4	Removal, mechanical variator .....	149
5.5.5	Assembly, mechanical variator .....	149
5.5.6	Reconditioning the mechanical variator pulley .....	150
5.5.7	Removal, hydraulic table clutch .....	151
5.5.8	Fitting the hydraulic table clutch .....	152
5.5.9	Reconditioning the hydraulic table clutch .....	153
<b>5.6</b>	<b>Rear beater</b> .....	158
5.6.1	Removing the rear beater .....	158
5.6.2	Fitting the rear beater .....	159
<b>5.7</b>	<b>Rear beater concave</b> .....	160
5.7.1	Removing the rear beater concave .....	160
5.7.2	Fitting the rear beater concave .....	160
<b>5.8</b>	<b>Rotor Feeder</b> .....	161
5.8.1	Removal, Rotor Feeder .....	161
5.8.2	Fitting the Rotor Feeder .....	162
5.8.3	Replacing the bearings .....	163
5.8.4	Replacing deflector and distributor plates .....	164

<b>5.9</b>	<b>Rotor Feeder concave</b> .....	166
5.9.1	Removal, Rotor Feeder concave .....	166
5.9.2	Fitting the Rotor Feeder concave .....	166
<b>6</b>	<b>Rotor unit</b> .....	167
<b>6.1</b>	<b>General</b> .....	169
6.1.1	General .....	169
<b>6.2</b>	<b>Rotor variator</b> .....	170
6.2.1	Removal, hydraulic variator .....	170
6.2.2	Assembly, hydraulic variator .....	171
6.2.3	Reconditioning the hydraulic variator pulley .....	172
6.2.4	Removal, mechanical variator .....	172
6.2.5	Assembly, mechanical variator .....	173
6.2.6	Reconditioning the mechanical variator pulley .....	173
6.2.7	Replacing and reconditioning the magnetic clutch .....	175
<b>6.3</b>	<b>Shaft for mechanical variator</b> .....	177
6.3.1	Removal .....	177
6.3.2	Assembly .....	177
<b>6.4</b>	<b>Right-angle gear</b> .....	178
6.4.1	Removing the right-angle gear .....	178
6.4.2	Fitting the right-angle gear .....	179
<b>6.5</b>	<b>Rotor</b> .....	181
6.5.1	Removal, rotor .....	181
6.5.2	Fitting the rotor .....	182
6.5.3	Replacing the front bearing .....	183
6.5.4	Replacing the rear bearing .....	184
<b>6.6</b>	<b>Rotor cage</b> .....	185
6.6.1	Removal .....	185
6.6.2	Assembly .....	187
6.6.3	Replacing grate sections .....	187
<b>7</b>	<b>Shaker shoe - Fanning mill</b> .....	189
<b>7.1</b>	<b>General</b> .....	191
7.1.1	Shaker shoe - fanning mill, general .....	191
<b>7.2</b>	<b>Fanning mill</b> .....	192
7.2.1	Removing the fanning mill .....	192
7.2.2	Fitting the fanning mill .....	193
7.2.3	Replacing the fan blades .....	193
7.2.4	Replacing the fanning mill deflectors .....	194
7.2.5	Replacing the seals .....	195
<b>7.3</b>	<b>Main grain pan frame</b> .....	196
7.3.1	General .....	196
7.3.2	Removal, main grain pan frame .....	196
7.3.3	Fitting the main grain pan frame .....	197
7.3.4	Replacing the swivel arm and bearings .....	198
7.3.5	Replacing the seals .....	199
<b>7.4</b>	<b>Second grain pan</b> .....	200
7.4.1	Removal .....	200
7.4.2	Fitting the second grain pan .....	200
7.4.3	Replacing the swivel arm and bearings .....	201
7.4.4	Adjusting second grain pan .....	202
<b>7.5</b>	<b>Top shaker shoe</b> .....	204
7.5.1	Removing the top shaker shoe .....	204
7.5.2	Assembly .....	205
7.5.3	Replacing the swivel arm and bearings .....	206
7.5.4	Replacement of seals .....	207
7.5.5	Replacing and calibrating the actuator - sieves .....	207
<b>7.6</b>	<b>Bottom shaker shoe</b> .....	209
7.6.1	Removing the bottom shaker shoe .....	209
7.6.2	Assembly .....	210
7.6.3	Replacing the swivel arm and bearings .....	211
7.6.4	Replacing the seals .....	211



7.6.5	Electric sieve setting – initial setting	211
<b>7.7</b>	<b>Bottom augers</b>	212
7.7.1	Removing the grain auger	212
7.7.2	Fitting the grain auger	212
7.7.3	Removing the returns bottom auger	213
7.7.4	Fitting the returns bottom auger	214
<b>7.8</b>	<b>Eccentric drive</b>	215
7.8.1	Removing the eccentric drive	215
7.8.2	Fitting the eccentric drive	216
7.8.3	Adjusting the connecting rod / aligning the shaker shoes	217
7.8.4	Replacing the connecting rod bearing	218
7.8.5	Replacing the bearings and eccentric shaft	219
<b>7.9</b>	<b>Transmissions</b>	220
7.9.1	Replacing and reconditioning the fanning mill variator	220
7.9.2	Adjusting the fanning mill variator	221
7.9.3	Replacing and reconditioning the counter drive	222
<b>8</b>	<b>Elevators - augers</b>	223
<b>8.1</b>	<b>Tank filling elevator</b>	225
8.1.1	Removing the tank filling elevator	225
8.1.2	Fitting the tank filling elevator	226
8.1.3	Replacing the top shaft, bearings and sprockets	227
8.1.4	Replacing the bottom sprocket	228
8.1.5	Replacing the elevator chain	229
<b>8.2</b>	<b>Returns auger</b>	230
8.2.1	Removing the returns auger	230
8.2.2	Fitting the returns auger	232
8.2.3	Replacing the top bearing	233
8.2.4	Removing and reconditioning the right-angle gear	233
<b>8.3</b>	<b>De-awner</b>	235
8.3.1	Removing the de-awner	235
8.3.2	Fitting the de-awner	235
<b>8.4</b>	<b>Tank filling auger</b>	236
8.4.1	Removing the pivotable part	236
8.4.2	Replacing the top bearing	236
8.4.3	Removing the fixed part bearing	237
8.4.4	Reconditioning the right-angle gear	238
<b>8.5</b>	<b>Transmission</b>	240
8.5.1	Replacing the countershaft and bearings	240
<b>9</b>	<b>Engine</b>	241
<b>9.1</b>	<b>General</b>	243
9.1.1	Engine, general	243
<b>9.2</b>	<b>Replacing the engine</b>	244
9.2.1	Removing the engine assembly	244
9.2.2	Fitting the engine assembly	247
<b>10</b>	<b>Unloading auger - Grain tank</b>	249
<b>10.1</b>	<b>Moisture sensor</b>	251
10.1.1	Removing the moisture sensor	251
<b>11</b>	<b>Drive unit</b>	253
<b>11.1</b>	<b>Radiator – intercooler</b>	255
11.1.1	Removal, combined radiator	255
11.1.2	Fitting, combined radiator	256
<b>11.2</b>	<b>Hydraulic oil cooler</b>	258
11.2.1	Removing the oil cooler	258
11.2.2	Fitting the oil cooler	258
<b>11.3</b>	<b>Fuel cooler</b>	259
11.3.1	Removing the fuel cooler	259
11.3.2	Fitting the fuel cooler	259

<b>11.4</b>	<b>Condenser – air conditioning</b>	260
11.4.1	Removing the condenser	260
11.4.2	Fitting the condenser	260
<b>11.5</b>	<b>Rotary screen</b>	261
11.5.1	Removing the rotary screen	261
11.5.2	Fitting the rotary screen	262
11.5.3	Adjusting the radiator cleaning plate	263
11.5.4	Reconditioning the countershaft drive	264
<b>11.6</b>	<b>Dust aspirator</b>	265
11.6.1	Removing the dust aspirator	265
11.6.2	Fitting the dust aspirator	265
11.6.3	Reconditioning the dust aspirator	266
<b>11.7</b>	<b>Hydrostatic pump</b>	267
11.7.1	Removing the hydrostatic pump	267
11.7.2	Fitting the hydrostatic pump	268
<b>11.8</b>	<b>Auxiliary hydraulic pump</b>	269
11.8.1	Removing the hydraulic pump	269
11.8.2	Fitting the hydraulic pump	269
<b>11.9</b>	<b>Hydraulic oil tank</b>	270
11.9.1	Removing the hydraulic oil tank	270
11.9.2	Fitting the hydraulic oil tank	270
<b>11.10</b>	<b>Fuel tank</b>	271
11.10.1	Removing the fuel tank	271
11.10.2	Fitting the fuel tank	272
11.10.3	Tank gauge	272
<b>11.11</b>	<b>SCR system</b>	273
11.11.1	Removing the DEF tank	273
11.11.2	Fitting the DEF tank	273
11.11.3	Removing the DEF catalytic converter	274
11.11.4	Fitting the DEF catalytic converter	275
11.11.5	Supply module	275
11.11.6	Dosing module	276
11.11.7	Tank sensor, DEF	276
<b>11.12</b>	<b>Compressor – air conditioning</b>	277
11.12.1	Removing the A/C compressor	277
11.12.2	Fitting the A/C compressor	277
<b>11.13</b>	<b>Power take-off</b>	278
11.13.1	Removing the power take-off	278
11.13.2	Fitting the power take-off	280
11.13.3	Replacing the clutch	280
11.13.4	Replacing the output shaft/bearings	281
<b>12</b>	<b>Transmissions</b>	283
<b>12.1</b>	<b>General</b>	285
12.1.1	Transmissions, General	285
<b>12.2</b>	<b>Countershaft</b>	286
12.2.1	Removing the countershaft	286
12.2.2	Fitting the countershaft	288
12.2.3	Replacing the bearings	288
<b>12.3</b>	<b>Replacing the belts, right-hand side</b>	289
12.3.1	Cutting table countershaft - knife drive, right side 35 ft	289
12.3.2	Elevator countershaft - hydraulic engine, reversing	289
12.3.3	Rear beater - counter drive, cylinder variator	290
12.3.4	Counter drive, variator - threshing cylinder	291
12.3.5	Rear beater - Rotor Feeder	292
12.3.6	Rear beater - fanning mill variator	293
12.3.7	Fanning mill variator - fanning mill	294
12.3.8	Countershaft - dust aspirator, rotary screen counter drive	294
12.3.9	Countershaft - countershaft	295
12.3.10	Countershaft - tank filling elevator, tank filling auger	295
12.3.11	Countershaft - returns augers	296
12.3.12	Rotary screen counter drive - rotary screen	297

12.3.13	Rotor countershaft - right-angle gear	297
<b>12.4</b>	<b>Replacing the chains, right-hand side</b>	298
12.4.1	Reel drive	298
12.4.2	Reel drive, 35 ft.	299
<b>12.5</b>	<b>Replacing the belts, left-hand side</b>	300
12.5.1	Table countershaft - knife drive	300
12.5.2	Cutting table countershaft - knife drive, left side 35 ft	300
12.5.3	PTO shaft – table countershaft	301
12.5.4	Counter pulley - elevator countershaft	301
12.5.5	Rear beater - elevator chain top shaft - idler gear	302
12.5.6	Countershaft - rear beater	303
12.5.7	Engine - countershaft	304
12.5.8	Engine - unloading auger counter drive 1	306
12.5.9	Unloading auger counter drive 1 - unloading auger counter drive 2	309
12.5.10	Countershaft - counter drive, straw chopper	310
12.5.11	Counter drive, straw chopper - straw chopper	310
12.5.12	Rear beater - countershaft, shaker shoe drive	311
12.5.13	Countershaft, shaker shoe drive - eccentric shaft	311
12.5.14	Countershaft – hydraulic pump, chaff spreader	312
12.5.15	Engine - rotor countershaft	312
12.5.16	Rotor countershaft - hydraulic pump, Maxi Spreader	313
12.5.17	Engine - hydrostatic pump	314
<b>12.6</b>	<b>Replacing the chains, left-hand side</b>	315
12.6.1	Table countershaft - table auger	315
12.6.2	Cutting table countershaft - table auger, 35 ft	315
12.6.3	Table auger - belt rollers (PowerFlow)	316
12.6.4	Table auger – belt rollers, 35 ft	316
12.6.5	Unloading auger counter drive 2 - bottom auger	317
<b>13</b>	<b>Undercarriage</b>	319
<b>13.1</b>	<b>Auto Level final drive bracket</b>	321
13.1.1	Removal	321
13.1.2	Assembly	322
13.1.3	Replacing the bushing	324
13.1.4	Replacing the hydraulic cylinder	325
13.1.5	Reconditioning of hydraulic cylinder	325
13.1.6	Adjusting the Auto Level potentiometer	326
<b>13.2</b>	<b>Final drives</b>	328
13.2.1	Removal	328
13.2.2	Assembly	329
13.2.3	Reconditioning the final drives	330
<b>13.3</b>	<b>Gearbox</b>	334
13.3.1	Removal	334
13.3.2	Assembly	335
13.3.3	Replacing the shifter cylinders and sensor	336
13.3.4	Adjusting the shifter cylinders and sensor	337
13.3.5	Replacing the lubrication pump	340
13.3.6	Replacing the shifter forks	341
13.3.7	Reconditioning the differential	342
13.3.8	Reconditioning the gearbox	345
<b>13.4</b>	<b>Hydrostatic motor</b>	349
13.4.1	Removal	349
13.4.2	Assembly	349
<b>13.5</b>	<b>Brakes</b>	351
13.5.1	Replacing the brake blocks	351
13.5.2	Replacing the brake discs	352
13.5.3	Bleeding the brakes	354
13.5.4	Replacing the parking brake shoes	354
13.5.5	Adjustment of hydraulic parking brake	355



<b>14</b>	<b>Hydraulics</b>	357
<b>14.1</b>	<b>General</b>	359
14.1.1	Hydraulics, general	359
14.1.2	Emptying and filling the hydrostatic system	359
14.1.3	Running in and bleeding the hydrostatic system 2WD	361
14.1.4	Running in and bleeding the hydrostatic system 4WD	363
14.1.5	Running in and bleeding the auxiliary hydraulics	365
<b>14.2</b>	<b>Hydraulic diagrams</b>	366
14.2.1	Standard Combines	366
14.2.2	Auto Level machines	375
<b>14.3</b>	<b>Hydraulic components</b>	386
14.3.1	Hydraulic valves	386
14.3.2	Hydraulic pumps	397
14.3.3	Hydraulic motors	404
<b>14.4</b>	<b>Hydrostatic system</b>	406
14.4.1	Transmission hydraulics 2WD	406
<b>14.5</b>	<b>Gearshift</b>	407
14.5.1	Gearshift	407
<b>14.6</b>	<b>Parking brake</b>	409
14.6.1	Parking brake	409
<b>14.7</b>	<b>Auxiliary hydraulics</b>	410
14.7.1	Auxiliary hydraulics, oil tank and oil cooler	410
<b>14.8</b>	<b>Cutting table</b>	412
14.8.1	Cutting table - hydraulics	412
<b>14.9</b>	<b>Auto Level</b>	415
14.9.1	Auto Level - hydraulics	415
<b>14.10</b>	<b>Reel</b>	417
14.10.1	Steering - hydraulics	417
<b>14.11</b>	<b>Steering</b>	421
14.11.1	Steering - hydraulics	421
<b>14.12</b>	<b>Cutting table clutch</b>	423
14.12.1	Cutting table engagement - hydraulics	423
<b>14.13</b>	<b>Cylinder variator</b>	424
14.13.1	Cylinder variator - hydraulics	424
<b>14.14</b>	<b>Rotor variator</b>	426
14.14.1	Rotor variator - hydraulics	426
<b>14.15</b>	<b>Threshing unit</b>	428
14.15.1	Threshing mechanism on/off - hydraulics	428
<b>14.16</b>	<b>Unloading auger</b>	429
14.16.1	Unloading auger out/in - hydraulics	429
14.16.2	Unloading auger on/off - hydraulics	431
<b>14.17</b>	<b>Reversing</b>	432
14.17.1	Reversing - hydraulics	432
<b>14.18</b>	<b>Chaff spreader</b>	434
14.18.1	Chaff spreader - hydraulics	434
<b>14.19</b>	<b>Maxi Spreader</b>	435
14.19.1	Maxi Spreader - hydraulics	435
<b>15</b>	<b>Electrical system</b>	437
<b>15.1</b>	<b>General</b>	439
15.1.1	Electrical system, general	439
<b>15.2</b>	<b>Description of TechData</b>	440
15.2.1	Description of TechData	440
<b>15.3</b>	<b>CAN connections</b>	441
15.3.1	CAN connections	441
<b>15.4</b>	<b>Failure codes</b>	444
15.4.1	Machine-related error codes	444
15.4.2	Engine-related error codes	453
<b>15.5</b>	<b>Relays and fuses</b>	480
15.5.1	Relays and fuses	480
<b>15.6</b>	<b>Connectors</b>	486
15.6.1	Front electric box	486

15.6.2	Rear electric box	488
<b>15.7</b>	<b>Diagrams overview</b>	491
15.7.1	Diagrams overview	491
<b>15.8</b>	<b>Wiring diagrams</b>	496
15.8.1	Electric diagrams, Standard Combine	496
15.8.2	Electric diagrams Auto Level machine	533
<b>15.9</b>	<b>Components</b>	569
15.9.1	Components	569
<b>16</b>	<b>Straw chopper</b>	631
<b>16.1</b>	<b>General</b>	633
16.1.1	Replacing and calibrating the electric actuator – straw deflectors	633
<b>16.2</b>	<b>Hydraulic pump - Maxi Spreader</b>	634
16.2.1	Removing the hydraulic pump	634
16.2.2	Fitting the hydraulic pump	635
<b>17</b>	<b>General assembly instructions</b>	637
<b>17.1</b>	<b>Fitting gib-head keys</b>	639
17.1.1	Fitting gib-head keys	639
<b>17.2</b>	<b>Fitting tightening pins</b>	640
17.2.1	Fitting tightening pins	640
<b>17.3</b>	<b>Fitting hydraulic pipes and screw connections</b>	641
17.3.1	Fitting hydraulic pipes and screw connections	641
<b>17.4</b>	<b>Fitting a flanged bearing with locking collar</b>	643
17.4.1	Fitting a flanged bearing with locking collar	643
<b>17.5</b>	<b>Fitting sliding bushings</b>	644
17.5.1	Fitting sliding bushings	644
<b>17.6</b>	<b>Removing the revolution sensor</b>	645
17.6.1	Removing the revolution sensor	645
<b>17.7</b>	<b>Fitting tightening rings</b>	646
17.7.1	Fitting tightening rings	646
<b>18</b>	<b>Miscellaneous data</b>	647
<b>18.1</b>	<b>General</b>	649
18.1.1	Miscellaneous data, general	649
<b>18.2</b>	<b>Speeds - adjustment values</b>	650
18.2.1	Speeds - adjustment values	650
<b>18.3</b>	<b>Maintenance</b>	651
18.3.1	Lubrication chart, intervals	651
18.3.2	Lubrication chart, right- and left-hand sides	654
18.3.3	Lubrication chart, front axles	658
18.3.4	Lubrication points, left-hand machine side	659
18.3.5	Lubrication points, right-hand machine side	678
18.3.6	Lubricants and operating fluids	692
18.3.7	Gear	694
	<b>Alphabetical index</b>	697



# 1. Introduction - Specifications

<b>1.1</b>	<b>Using the manual</b> . . . . .	15
1.1.1	Using the manual . . . . .	15
<b>1.2</b>	<b>General specifications</b> . . . . .	16
1.2.1	Dimensions and specifications . . . . .	16
1.2.2	Specification table for tyres with equipment . . . . .	25
<b>1.3</b>	<b>Safety precautions</b> . . . . .	28
1.3.1	Safety precautions . . . . .	28
1.3.2	Safety in the workshop . . . . .	28
1.3.3	Safety - a word to the mechanic . . . . .	28
1.3.4	Safety - danger, warning and caution . . . . .	28
1.3.5	Safety decals . . . . .	29
1.3.6	General . . . . .	29
1.3.7	Personal safety . . . . .	29
1.3.8	Considerations with regard to equipment . . . . .	30
1.3.9	General considerations . . . . .	31
1.3.10	Operational considerations . . . . .	31
1.3.11	Maintenance techniques . . . . .	32
<b>1.4</b>	<b>Practical advice</b> . . . . .	34
1.4.1	Practical advice . . . . .	34
<b>1.5</b>	<b>Start-up instructions</b> . . . . .	38
1.5.1	General . . . . .	38
1.5.2	Pre-delivery checks . . . . .	38
1.5.3	Instruction of combine operator . . . . .	40
<b>1.6</b>	<b>Conversion tables</b> . . . . .	43
1.6.1	Conventional units of measurement . . . . .	43
<b>1.7</b>	<b>Locking and sealing agents</b> . . . . .	44
1.7.1	Locking and sealing agents . . . . .	44
<b>1.8</b>	<b>Wheel nut torques</b> . . . . .	45
1.8.1	Wheels . . . . .	45
1.8.2	Bolts with metric threads . . . . .	45
1.8.3	Nuts with metric threads . . . . .	46



## 1.1 Using the manual

### 1.1.1 Using the manual

T008027

#### General

All operations described in this manual relating to repairs and maintenance must only be carried out by trained service personnel. The purpose of the manual is to help dealers and workshops start up, service and repair AGCO's equipment as efficiently and effectively as possible. If the specified procedures are followed and the recommended special tools used where necessary, jobs can be completed within the time indicated in the "Repair Time Schedule" manual.

#### Pagination

Example: [see §3.1.3, page 89](#)

This manual is divided into chapters and sections. In the example the figures show:

First figure = Chapter

Second figure = Section

Third figure = Consecutive number in the section in question

69 = Page number in manual

The publication number and version appear at the bottom of the page.

#### Use

To make it easier to look things up, there is a table of contents at the beginning of every chapter listing the various sections in the chapter.

#### Modifications

Modified pages have the same section numbering as their predecessors: Only the page number and version number change.

The old pages must be destroyed.

#### Service tools

In the case of jobs that require service tools, the number of the tool is specified at the point in the text where it is needed.

#### Repairs and replacing parts

When replacing parts, it is very important to only ever use genuine AGCO spares.

Please pay particular attention to the following points when it comes to repairs and fitting spare parts or other equipment.

Fitting non-genuine spare parts may impair the safety of the machine.

In some countries it is against the law to fit parts that do not conform to the manufacturer's specifications. Torque wrenches must always be adjusted in accordance with the instructions given in the workshop manual. Fit locking devices where specified. If the locking device breaks when removed, fit a new one.

If non-genuine AGCO parts are fitted, the machine will no longer be covered by the right to complain, as the manufacturer provides a warranty on all AGCO components. AGCO dealers are under the obligation to supply genuine parts only.

#### Repair Time Schedule

The "Repair Time Schedule" manual contains a table of standard time requirements for the commonest repairs on a combine. The manual's sections follow the layout of the spare parts catalogue.

1

## 1.2 General specifications

### 1.2.1 Dimensions and specifications

T007303

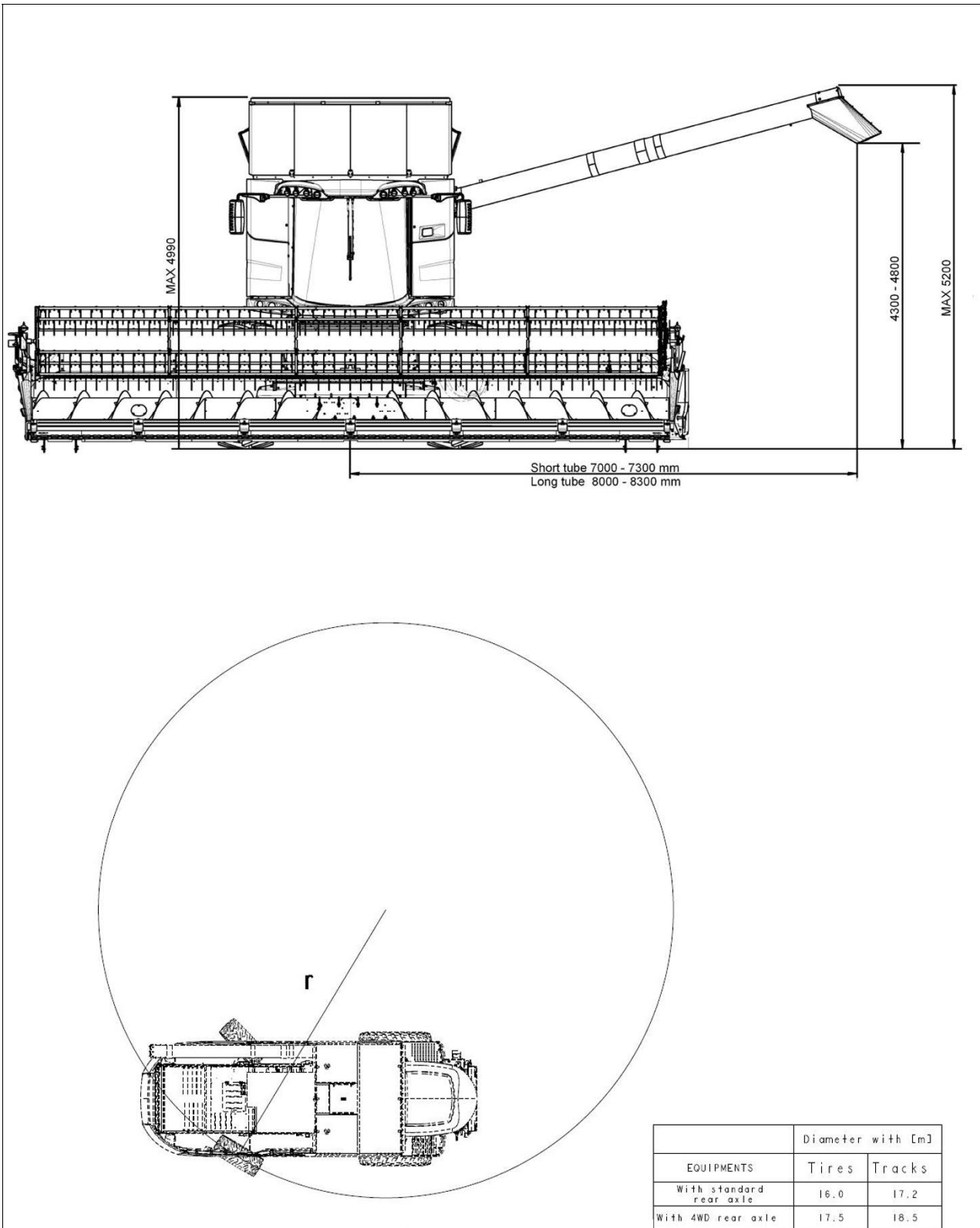

Fig. 1. Dimensions with cutting table and active unloading tube; dimensions for turning circle

I049946

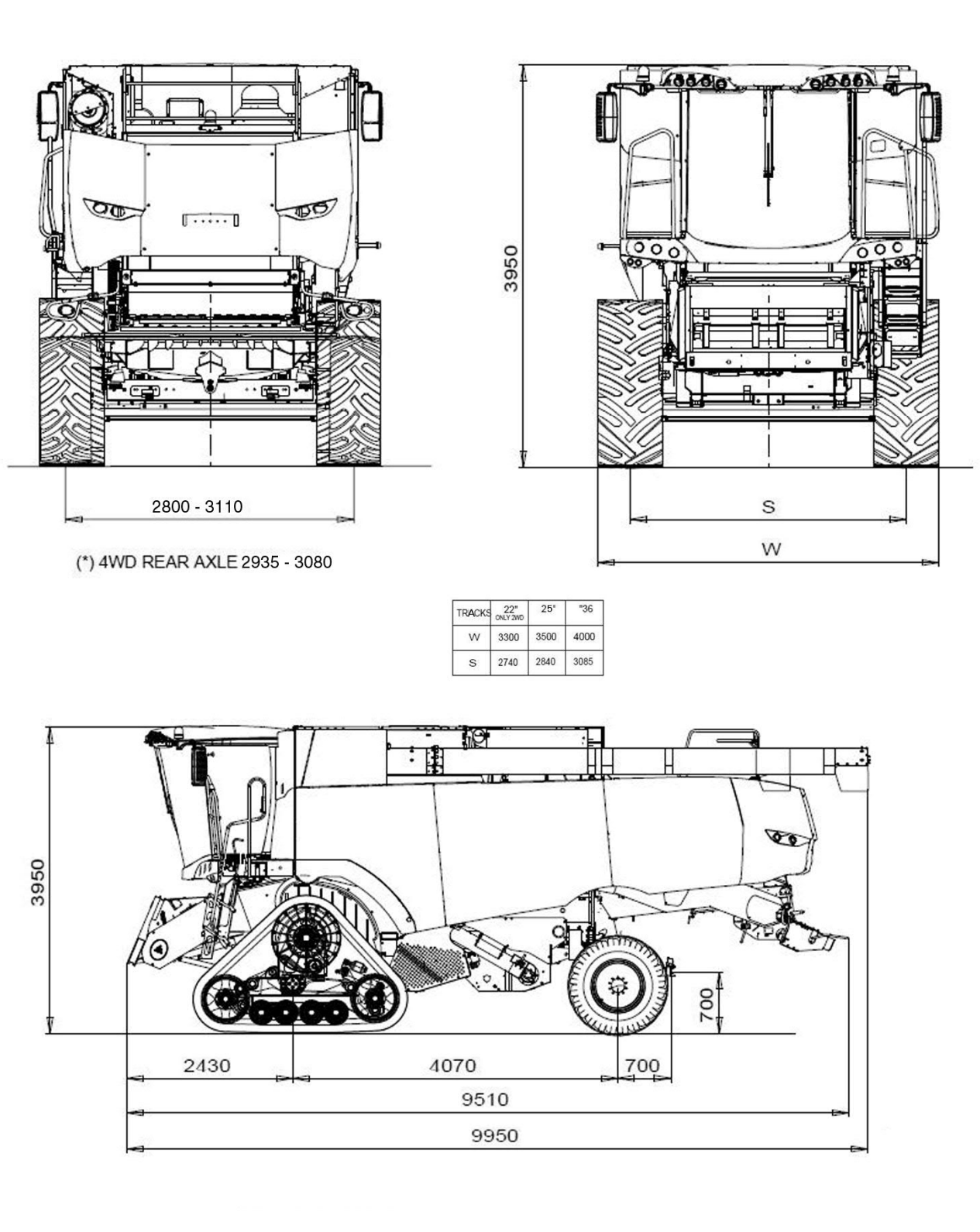
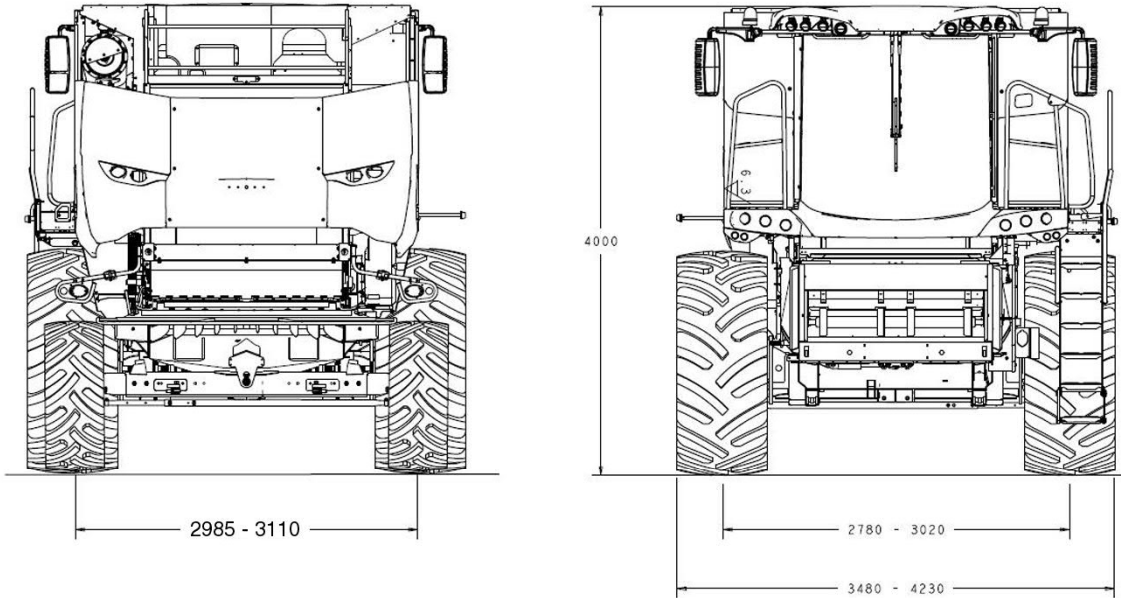

Fig. 2. Dimensions for tracked machines; front, rear, side

1049947



1



(\*) 4WD REAR AXLE 2935 - 3080

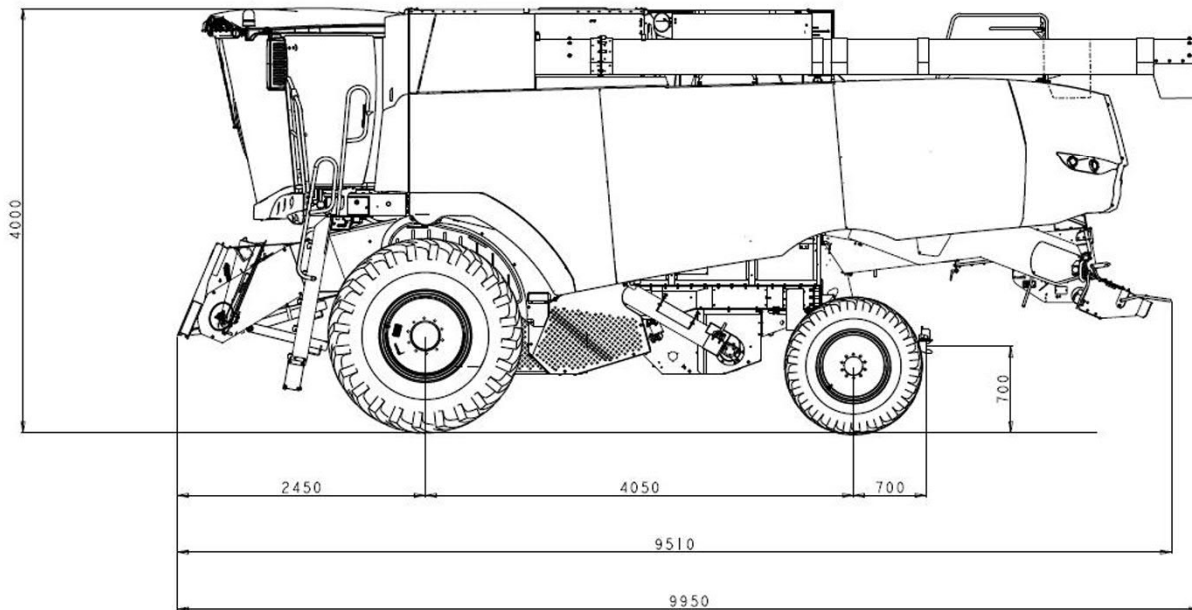

Fig. 3. Dimensions for machines with tyres; front, rear, side

1049948

FEEDING DEVICE	Unit	MF 9380 DELTA + Auto Level
<b>CUTTING TABLE</b>	-	PowerFlow
<b>MAIN CROP ELEVATOR</b>	-	Universal type
- Elevator chain front shaft	-	Spring-loaded
- Chains with slats	units	4
- Slats	units	21

<b>FEEDING DEVICE</b>	<b>Unit</b>	<b>MF 9380 DELTA + Auto Level</b>
- Overload cutout	-	Spring-loaded slip clutch
- Top shaft speed	rpm	500
- Front shaft speed	rpm	620
- Main crop elevator drive belt	-	Powerband belt

<b>THRESHING UNIT</b>	<b>Unit</b>	<b>MF 9380 DELTA + Auto Level</b>
- Stone trap	-	Fitted
<b>CYLINDER</b>	-	-
- Type: Grain/maize	-	Med 8 rasp bars
- Cylinder housing width	mm	1680
- Cylinder width	mm	1660
- Diameter	mm	600
- Variator	-	With one drive belt
- Variator control	-	Electro-hydraulic
- Speed	rpm	370 - 1080
<b>CONCAVE</b>	-	-
- System	-	Adjustable from operator seat
- Area	m <sup>2</sup>	1.06
Grain type:	-	-
- Clearance (between wire centres)	mm	15
- Wire location	mm	Alternating 350 and 700
- Wrap angle	degrees	- 117°
- Wire diameter	mm	3.5
- Total number of wires	units	110
- Rub bars	-	12
Maize type:	-	-
- Distance	mm	25
- Wrap angle	degrees	117°
- Wire diameter	mm	6
- Rub bars	units	12
<b>ROTOR FEEDER</b>	-	-
- Speed, normal	rpm	950
- Speed, low gear	rpm	515
- Diameter	mm	500
- Width	mm	1680
<b>ROTOR</b>	-	-
- Quantity	units	2
- Diameter	mm	475
- Length	mm	4150
- Area with Rotor Feeder	m <sup>2</sup>	0.35
- Separator area	m <sup>2</sup>	3.54
- Wrap angle, rotor grate	degrees	150°

1

THRESHING UNIT	Unit	MF 9380 DELTA + Auto Level
- Speed	rpm	360 - 1000
Rotor fingers (per rotor)	units	38
- Hatch in straw hood for cleaning rotor discharge	-	Yes
<b>REAR BEATER</b>	-	-
- Drive	-	Powerband belt
- Speed	rpm	945
- Wrap angle, concave	degrees	44°
- Concave area	m <sup>2</sup>	0.34
- Rub bars	units	6
- Distance	mm	75
- Wire diameter	mm	6

CLEANING DEVICE	Unit	MF 9380 DELTA + Auto Level
<b>FANNING MILL</b>	-	-
- Speed, normal	rpm	460 - 1150
- Speed, low gear	rpm	310 - 790
- Drive	-	Variator belt
<b>MAIN GRAIN PAN</b>	-	-
- Type	-	Stepped plates, removable for cleaning
- Movement	-	Alternating, opposite bottom shaker shoe
- Connecting rod	strokes/min.	295
- Drive	-	Double V-belts
- Main grain pan, width	mm	1660
- Main grain pan, length	mm	1680
- Main grain pan, area	m <sup>2</sup>	2.79
- Rake extension	m <sup>2</sup>	0.4
<b>TOP SIEVE</b>	units	2
- Top sieve, width	mm	813
- Top sieve, length	mm	1811
- Top sieve, area	m <sup>2</sup>	1.47
<b>BOTTOM SIEVE</b>	units	2
- Bottom sieve, width	mm	813
- Bottom sieve, length	mm	1400
- Bottom sieve, area	m <sup>2</sup>	1.14
<b>RETURNS SYSTEM</b>	-	-
- Type	-	Optional rethreshing
- Material transport	-	Via returns auger
- Speed, returns auger	rpm	450 - 800

<b>GRAIN TANK</b>	<b>Unit</b>	<b>MF 9380 DELTA + Auto Level</b>
- Material transport	-	Via tank filling elevator and auger to the centre of the grain tank
- Speed, tank filling elevator	rpm	450
- Capacity	l	12500 (AL 10500)
- Draw, unloading auger	-	Powerband belt, chain and angle gear
- Overload cutout	-	Locking bolt
- Length, unloading auger	mm	5765 - 6865
- Unloading speed	l/sec.	120
- Unloading height	mm	4300 - 4800

<b>HYDRAULIC SYSTEM</b>	<b>Unit</b>	<b>MF 9380 DELTA + Auto Level</b>
- Capacity, oil tank (combined)	l	36
- Capacity, hydraulic pump for cutting table	l/min.	68
- Max. pressure for valve block, cutting table	bar	185
- Capacity, auxiliary hydraulic pump	l/min.	68
- Max. pressure for valve block, auxiliary hydraulics	bar	185
- Hydrostatic control pump, volume	cm <sup>3</sup> /rev.	11
- Capacity, hydrostatic control	cm <sup>3</sup>	260
- Max. pressure	bar	140
- Choke valve, max. pressure	bar	200
- Return filter	micron	16

<b>HYDROSTATIC SYSTEM</b>	<b>Unit</b>	<b>MF 9380 DELTA + Auto Level</b>
- Capacity, oil tank (combined)	l	36
- Pump stroke volume	cm <sup>3</sup> /rev.	145
- Pump	rpm	2620
- Settings, pressure relief valve	bar	450
- Engine stroke volume	cm <sup>3</sup> /rev.	107
- Return filter	micron	16

<b>ENGINE</b>	<b>Unit</b>	<b>MF 9380 DELTA + Auto Level</b>
- Make	-	AGCO POWER
- Type	-	98AWF953
- Cylinders	units	7
- Stroke volume	cm <sup>3</sup>	9822
- Bore	mm	111
- Stroke length	mm	145
- Turn direction (from flywheel)	-	Anti-clockwise
- Speed, idling	rpm	2100 ± 50
- Speed, fully loaded	rpm	2100

1

ENGINE	Unit	MF 9380 DELTA + Auto Level
- RPM at max. torque	rpm	1950
- Maximum power (ECE R 120)	kW	360
- Maximum power (ECE R 120 with Power Boost)	kW	365
- Nominal power (at 2100 rpm)	kW	343
- Nominal power (with Power Boost)	kW	364
- Capacity, engine oil	l	33
- Capacity, DEF tank	l	115
- Capacity, fuel tank	l	1000
<b>RADIATOR</b>	-	-
- Capacity, circuit	l	56

ELECTRICAL COMPONENTS	Unit	MF 9380 DELTA + Auto Level
<b>BATTERY</b>	-	-
- Type 12V	A/h	200
- Peak current	A	1200
<b>STARTER MOTOR</b>	-	-
- Type	-	12V
<b>ALTERNATOR</b>	-	-
- Type	-	12V
- Charge capacity	A	150

GEAR OIL	Unit	MF 9380 DELTA + Auto Level
Gearbox contains	litres	9.5
Coupler housing for oil motor	litres	1.5
Final drives contain	litres	6
The rotor gear has a capacity of	litres	1.5

TRANSMISSION	Unit	MF 9380 DELTA + Auto Level
- Gear type	-	With normal gearshift
- Gear	units	4
<b>TYRE</b>	-	-
Speed (forward and reverse) with tyres 710/75R34	-	-
- 1st gear (work)	km/h	0 - 6.80
- 2nd gear (work)	km/h	0 - 11.70
- 3rd gear (work)	km/h	0 - 17
- 4th gear (work)	km/h	-
- 4th gear (driving on roads)	km/h	30 (*)
<b>TRACKS</b>	-	-
- 1st gear (work)	km/h	0 - 6.10
- 2nd gear (work)	km/h	0 - 10.50
- 3rd gear (work)	km/h	0 - 17

Thank you so much for reading.  
Please click the “Buy Now!”  
button below to download the  
complete manual.



After you pay.

You can download the most  
perfect and complete manual in  
the world immediately.

Our support email:

[ebooklibonline@outlook.com](mailto:ebooklibonline@outlook.com)