

KOBELCO

SERVICE MANUAL

mitsubishi DIESEL ENGINE

6D2

For Industrial Use

Applicable Models: K909A, K910, K912, K935

MITSUBISHI DIESEL ENGINE

SHOP MANUAL

MODEL 6D2

(FOR INDUSTRIAL USE)

6D22-102943
and up

K909A
K910
K912
K935

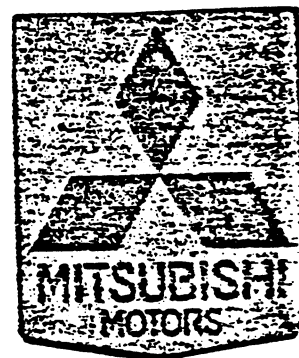

FOREWORD

This shop manual contains the specifications, construction, operation, adjustment and service procedures of the Model 6D22, 6D22T diesel engine for service mechanics engaged in servicing of the Mitsubishi diesel engines.

Please make the most of this shop manual to perform correct servicing and wasteless operations.

Note that some of the contents of this shop manual are subject to change owing to improvements, etc. that may be introduced after publication of the shop manual.

[Applicable Engine No.]
6D22-102843
(including 6D22T)

COMPILATION OF THIS MANUAL

1. The contents of this shop manual are divided as shown below when edited.

Group No.	Group Name	Contents
1	General	General description, outside view photograph and cross section view of engine, specifications, construction and operation
2	Service standards	Engine service standards, service standards table, tightening torque table, sealant and grease table
3	Special tools	Shapes and usages of special tools
4	Determining time to overhaul	Decision on time to overhaul, measurement of compression pressure, troubleshooting
5	Engine adjustment and break-in operation	Inspection and adjustment of valve clearance, inspection and adjustment of fuel injection start timing, engine speed adjustment
6	Removal and installation of auxiliaries	Removal and installation of auxiliaries such as injection pump, starter, alternator and compressor
7	Engine proper	Disassembly, inspection and reassembly of engine proper, including cylinder head, valve mechanism, camshaft, piston, crankshaft, timing gear, flywheel, etc.
8	Inlet and exhaust	Disassembly, inspection and reassembly of air cleaner, turbocharger, etc.
9	Lubrication	Disassembly inspection and reassembly of lubrication system, including oil pump, oil filter, oil cooler, etc.
10	Cooling	Disassembly, inspection and reassembly of cooling system, including water pump, thermostat, radiator, etc.
11	Fuel	Disassembly, inspection and reassembly of fuel system, including injection pump, injection nozzle, fuel filter, water separator, etc.
12	Electrical	Inspection of starter, starter relay, alternator, etc.
13	Other equipment	Disassembly, inspection and reassembly of air compressor, automatic stop device.
14	Clutch	Disassembly, inspection and reassembly of clutch, bearing case.

2. How to read disassembly and reassembly drawings

- (a) The part names and numbers in the drawings correspond to those in the text. The parts are numbered in the order of disassembly.
- (b) The inspection items to be performed during disassembly operations are shown in the disassembly drawings.
- (c) All tightening torque specifications in the reassembly drawings may be considered "dry" unless "wet" is specified.

3. Definition of terms

(a) Nominal Value (Abbr.: NV)

Shows dimension of single part, mutual clearance between parts or standard performance. Values, however, are rounded off within limits necessary for inspection.

(b) Repair Limit (Abbr.: RL)

Shows that when specified value is reached, repair is necessary. Repair means adjustment, grinding, replacement of bushings, metals and the like, selection of oversize, selection of shim thickness, etc.

(c) Service Limit (Abbr.: SL)

Shows that when specified value is reached, replacement of the parts with new one is necessary.

(d) Basic Diameter (Abbr.: BD)

Shows nominal diameter of part to be measured.

4. Unit

The SI unit (International System of Units) is used. Metric notation is jointly shown in parentheses.

5. Table of Conversion Rate for Foot-pound Units into SI Units

Unit	Sign of SI unit	Sign of foot-pound unit	Conversion rate
Mass quantity of matter	kg g	lb oz	1 kg = 2.2046 lb 1 g = 0.035274 oz
Dimension	m mm	ft. in.	1 m = 3.2808 ft. 1 mm = 0.03937 in.
Capacity	lit. cc	gal. oz	1 lit. = 0.2642 gal. (U.S.) 0.220 gal. (Imp.) 1 cc = 0.033814 oz (U.S.) 0.035195 oz (Imp.)
Force	N (Newton)	lbf	1 N = 0.2248 lbf
Pressure	kPa (Kilopascal)	lbf/in. ²	1 kPa = 0.145 lbf/in. ² 1 kPa = 0.2953 in. Hg
Stress	N/cm ²	lbf/in. ²	1 N/cm ² = 1.45 lbf/in. ²
Moment of force	N m	ft. lbf	1 N m = 0.7375 ft.lbf
Output	kW (kilowatt)	HP	1 kW = 1.34 HP
Temperature	°C	°F	t°C = (1.8t°C + 32)°F

CONTENTS

1. GENERAL	1
2. SERVICE STANDARDS	2
3. SPECIAL TOOLS	3
4. DETERMINING TIME TO OVERHAUL	4
5. ENGINE ADJUSTMENT AND BREAK-IN OPERATION	5
6. REMOVAL AND INSTALLATION OF AUXILIARIES	6
7. ENGINE PROPER	7
8. INLET AND EXHAUST	8
9. LUBRICATION	9
10. COOLING	10
11. FUEL	11
12. ELECTRICAL	12
13. OTHER EQUIPMENT	13
14. CLUTCH	14

T- GENERAL



CONTENTS

1-1 GENERAL DESCRIPTION 2

 1-1-1 Outside View Photographs 2

 1-1-2 Engine Sectional Views 4

 1-1-3 Engine Number, Nameplate and Caution
 Plate 8

1-2 SPECIFICATIONS 9

 1-2-1 Principal Specifications 9

 1-2-2 Specifications of Each Device 10

 1-2-3 Engine Outputs Classified by
 Application 16

1-3 CONSTRUCTION AND OPERATION 17

 1-3-1 Engine Proper 17

 1-3-2 Inlet and Exhaust 25

 1-3-3 Lubrication 29

 1-3-4 Cooling 35

 1-3-5 Fuel 38

 1-3-6 Electrical 58

 1-3-7 Other Equipment (Option) 67

 1-3-8 Clutch (Option) 70

1-1 GENERAL DESCRIPTION

1-1-1 Outside View Photographs

(1) [6D22]

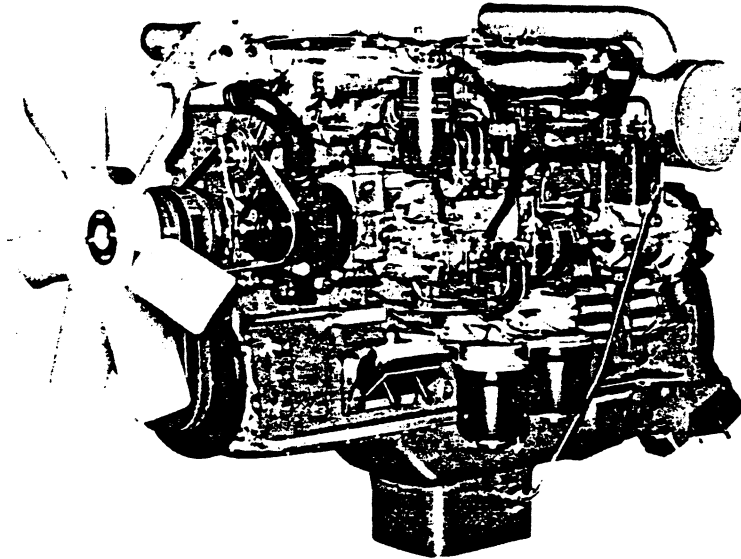

PE3053

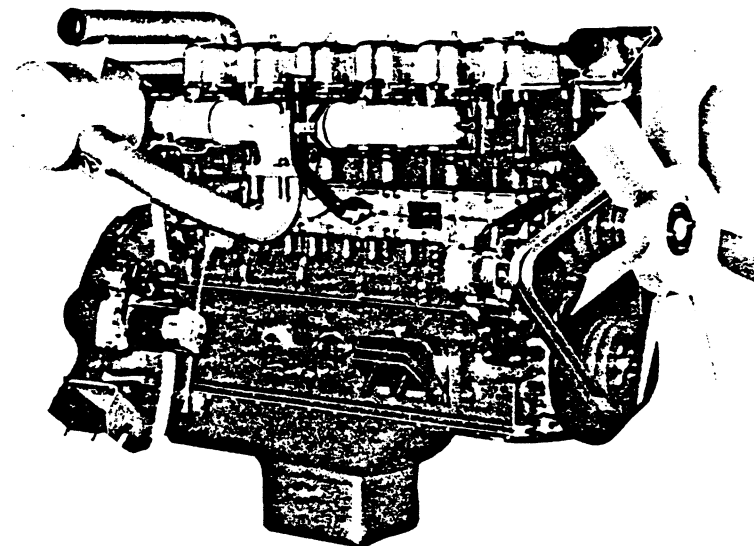

PE3054

(2) [6D22T]

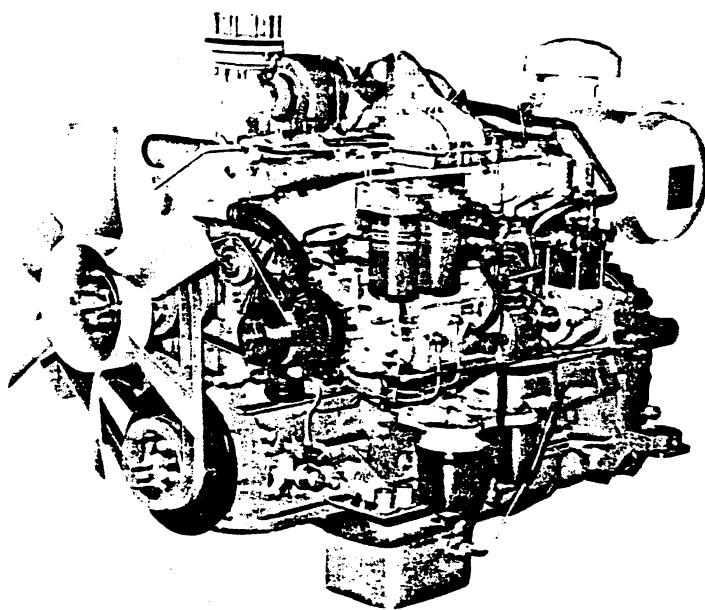

PE3055

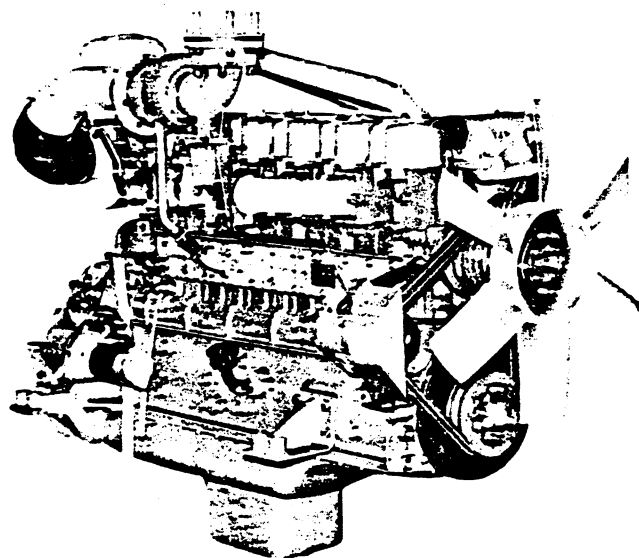

PE3056

1-1-2 Engine Sectional Views

(1) [6D22]

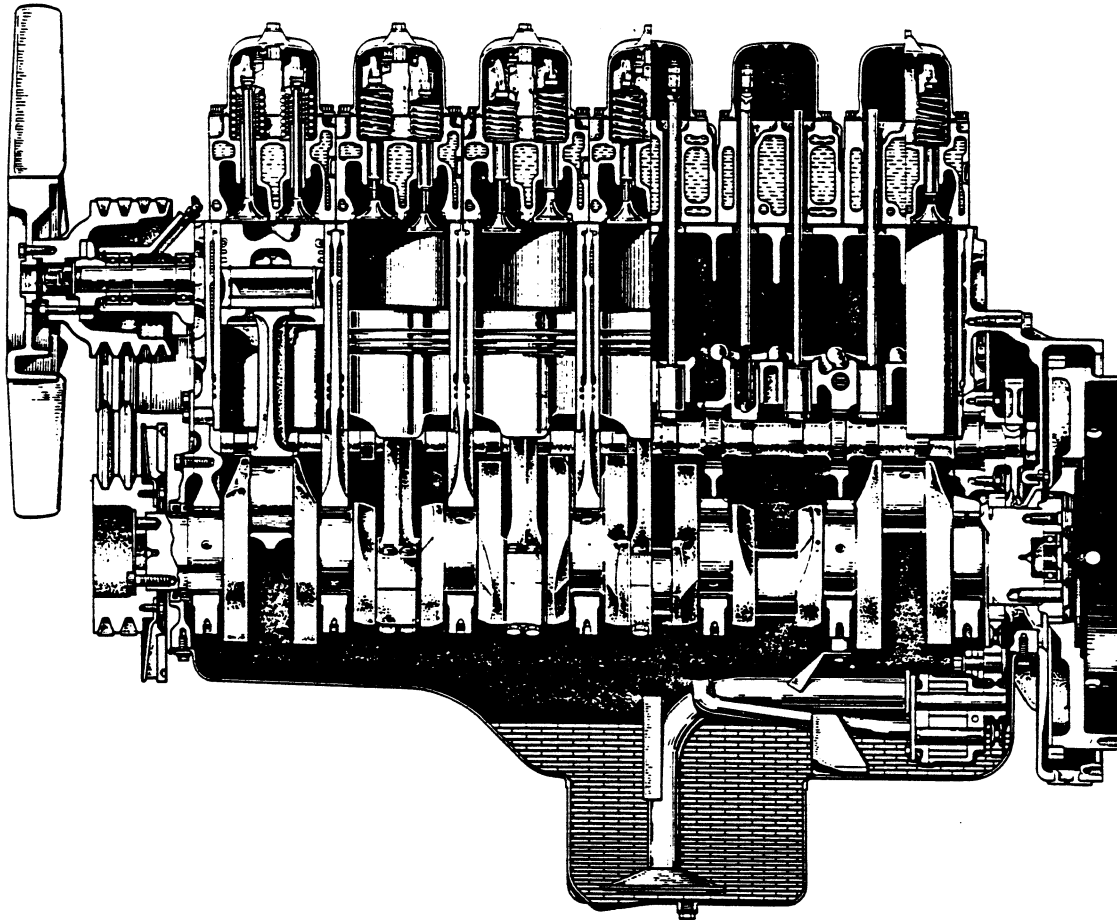

LE7988

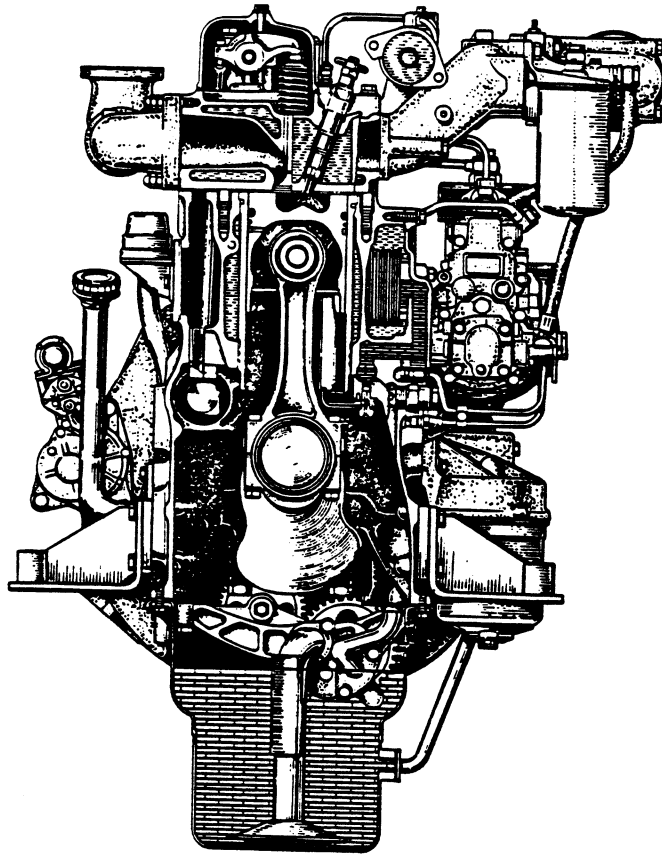

LE7989

(2) [6D22T]

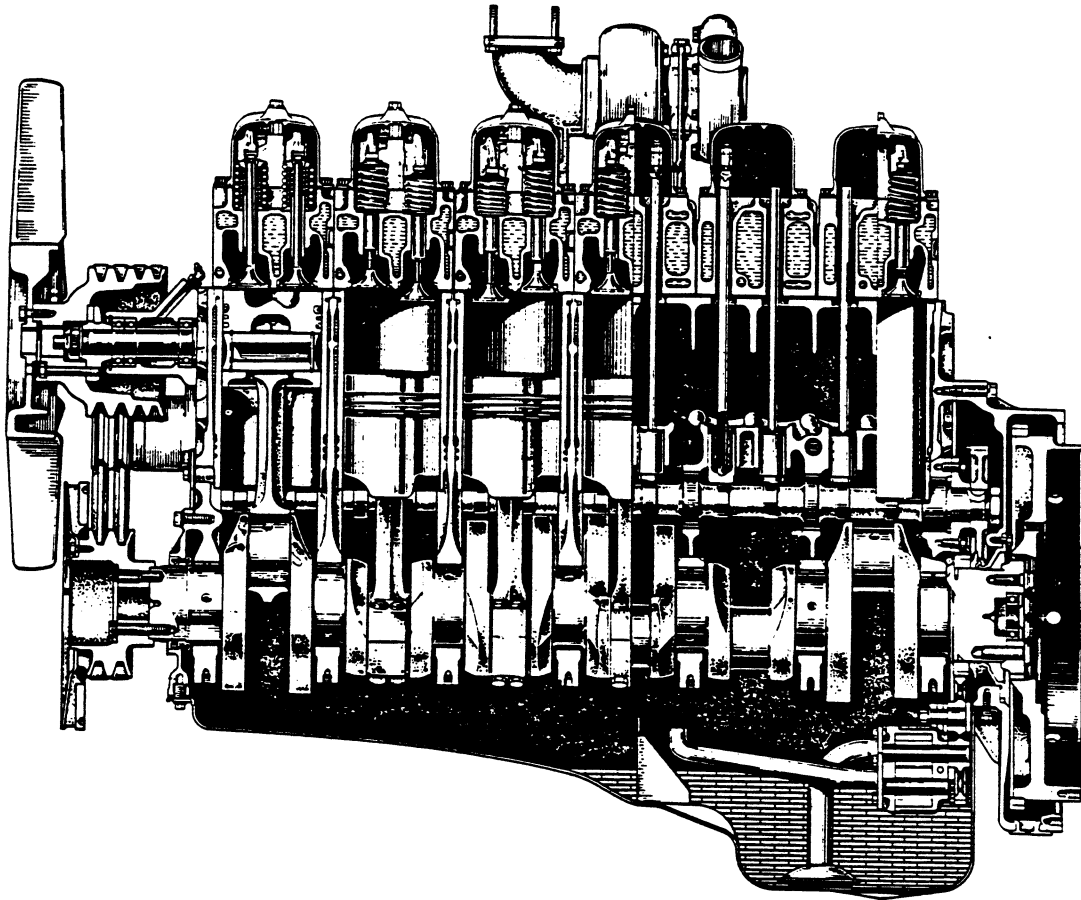

LE7990

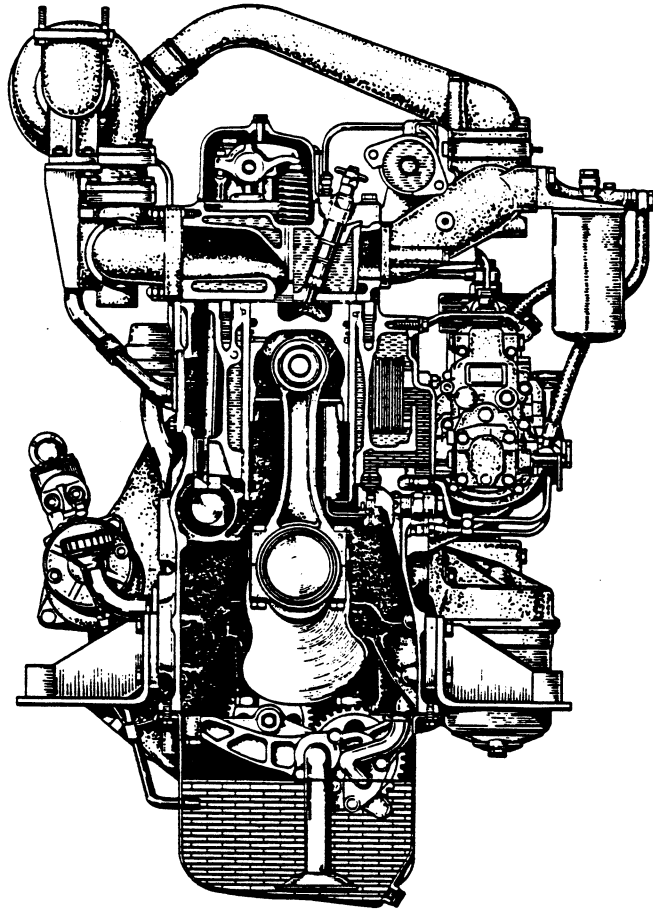

LE7991

1-1-3 Engine Number, Nameplate and Caution Plate

(1) Engine Number

The engine number is stamped on the left side of the crankcase, near the front portion, as shown below.

Example	Model	Engine No.
	6D22	- 102843

The engine number is important in knowing the history of the engine.

6D22-102843

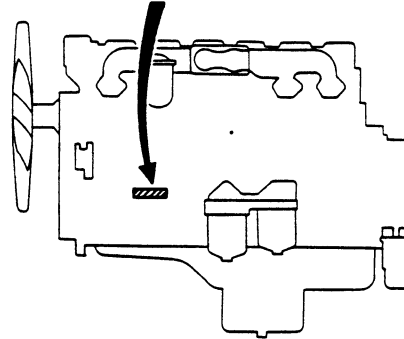

(2) Nameplate

The nameplate is bonded to the side cover on the right side of the engine and shows the following:

- Engine Model
- Total Displacement
- Output
- Valve Clearance
- Firing Order
- Fuel Injection Timing

LE7992

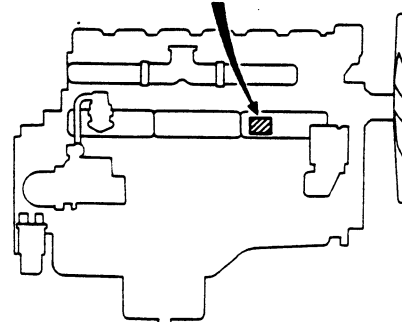
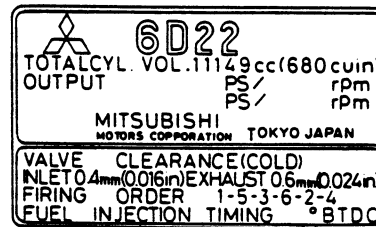

LE7993

(3) Caution Plate

The caution plate is bonded to the rocker cover and shows the following:

- Valve Clearance
- Firing Order
- Fuel Injection Timing

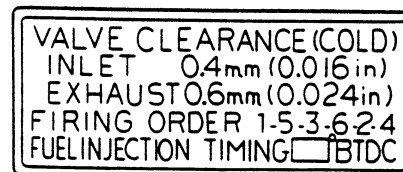

LE7994

1-2 SPECIFICATIONS

1-2-1 Principal Specifications

Item	Specification	
Engine model	6D22	6D22T
Type	Water cooled, 4-cycle diesel	Water cooled, 4-cycle diesel
Number of cylinders-arrangement	6-in-line	6-in-line
Valve mechanism	Overhead Valve	Overhead Valve
Combustion chamber	Direct injection type	Direct injection type
Cylinder bore x stroke mm	130 x 140	130 x 140
Total displacement cc	11 149	11 149
Compression ratio	17	16
Firing order	1-5-3-6-2-4	1-5-3-6-2-4
Engine dimensions		
Overall length mm	1 585	1 665
Overall width mm	905	872
Overall height mm	1 113	1 205
Weight kg	930	970

The engine dimensions and weight shown are Mitsubishi Motors Corporation standard specifications.

1-2-2 Specifications of Each Device

Engine Proper

Item	Specifications
Cylinder liner Type	Wet type
Piston Type	Trunk-shaped, slipper skirt type
Piston rings Q'ty	Two compression rings One oil ring

Inlet and Exhaust

Item	Specifications
Air cleaner	(Nippon Donaldson Ltd. product)
Element Type	Cyclone filter paper type
Turbocharger	[6D22T]
Type	Turbocharger
Model	Mitsubishi Schwitzer 3LM

Lubrication

Item		Specifications			
		[6D22]		[6D22T]	
Engine oil	Quality	API classification "FOR SERVICE CC" or better		API classification "FOR SERVICE CD" or better	
		For general power	For con- struction machinery	For general power	For con- struction machinery
Oil pan oil quantity		Approx. 27 lit.	Approx. 25 lit.	Approx. 27 lit.	Approx. 25 lit.
Oil filter oil quantity		Approx. 3 lit.	Approx. 3 lit.	Approx. 3 lit.	Approx. 3 lit.
Lubricating system		Oil pump forced feed system			
Oil pump	Type	Gear pump forced feed system			
Relief valve	Type	Ball valve type			
Oil filter					
Full flow filter element type		Filter paper type			
Bypass filter element type		Filter paper type			
Oil bypass alarm type		Piston valve type with electric contacts			
Oil cooler	Type	Shell and plate type (multi-plate type)			
Bypass valve	Type	Piston valve type			
Regulator valve	Type	Piston valve type			
Oil jet					
Check valve	Type	Piston valve type			

Cooling

Item	Specifications
Cooling system	Water-cooled, forced circulation system
Cooling water quantity (Engine proper)	24 lit.
Water pump Type	Centrifugal type
Drive system	V-belt drive
V-belt Type x quantity	(With fan) Low edge cog Type B x 1 (for water pump) Low edge cog Type C x 2 (for fan drive) (Without fan) Low edge cog Type C x 1 (for water pump)
Thermostat Type	Wax pellet type bottom bypass system
Valve opening temperature x q'ty	76.5°C x 2
Fan Type	Made of polypropylene, blow-off type (Option) Made of polypropylene, suction type
Radiator Type	Tube and plate fin type
Radiator cap Type	Pressure type
Boiling temperature	110°C

Fuel

Item	Specifications		
	(Diesel Kiki Co., Ltd. products)		
	[6D22]	[6D22T]	
		(Standard)	(Option)
Injection pump proper			
Type	Bosch Type AD	Bosch Type P	Bosch Type P
Model	NP-PE6AD105	NP-PE6P120	NP-PE6P120
Turning direction (as viewed from drive side)	Clockwise	Clockwise	Clockwise
Plunger			
Diameter	10.5 mm	12 mm	12 mm
Lead	L.H. double lead	R.H. single lead	R.H. double lead
Governor			
Type	All speed governor	All speed governor	Minimum maximum mechanical governor
Model	RSV	RSV	RFD
Feed pump			
Model	NP-FP/KE22AC	NP-FP/K22PC	NP-FP/K22PC
Automatic timer			
Type	Mechanical automatic timer	Mechanical automatic timer	Mechanical automatic timer
Model	SA	SP	SP
Injection nozzle			
Type	Hole type (1-spring nozzle)	(Standard) Hole type (1-spring nozzle)	(Option) Hole type (2-spring nozzle)
Model	NP-DLLA	NP-DLLA	NP-DLLA
No. of orifices	4	4	4
Orifice diameter	0.37 mm	0.37 mm	0.37 mm
Orifice angle	154°	154°	154°
Injection pressure	220 kgf/cm ²	220 kgf/cm ²	180 kgf/cm ²

Thank you so much for reading.
Please click the “Buy Now!”
button below to download the
complete manual.



After you pay.

You can download the most
perfect and complete manual in
the world immediately.

Our support email:

ebooklibonline@outlook.com