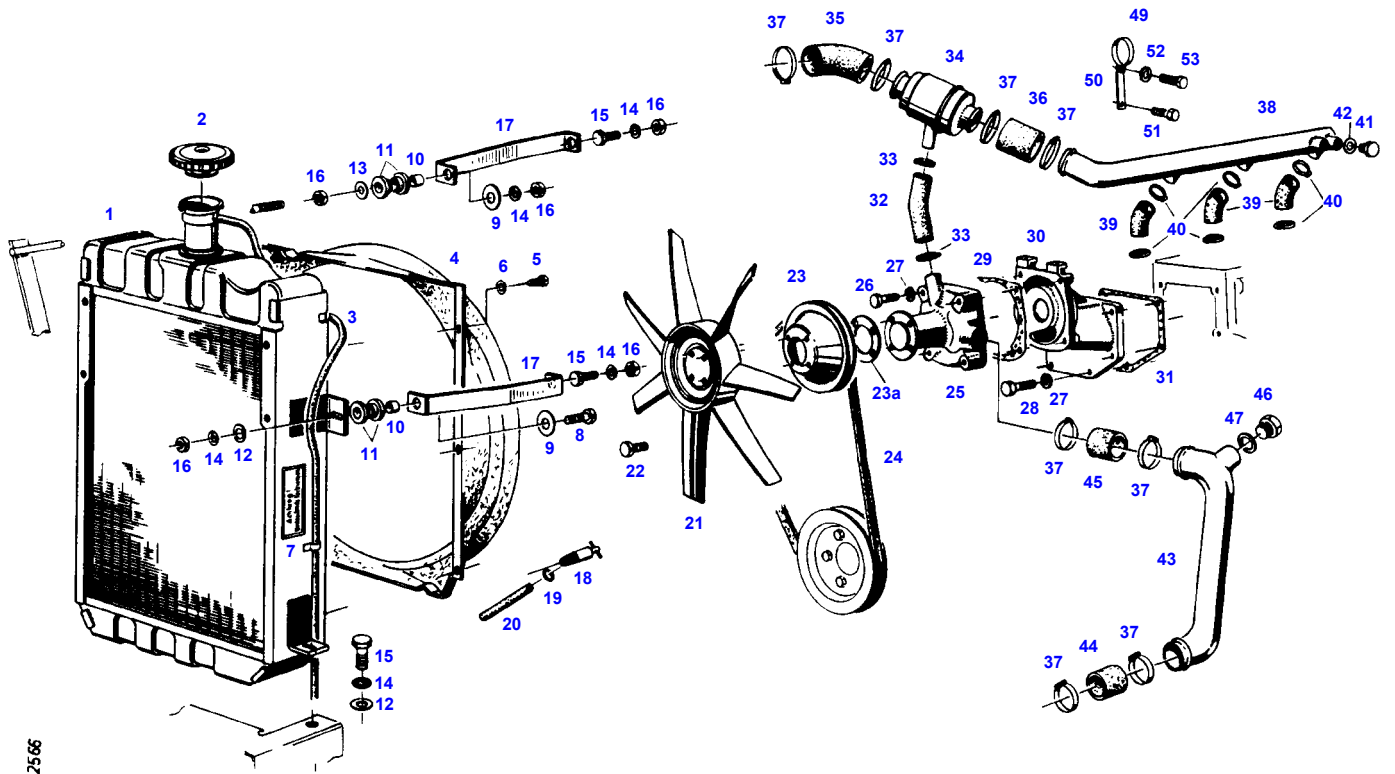

TABLE OF CONTENT

Page Number	Page Title	Page Reference
01-000-TOC	ENGINE, FUEL AND EXHAUST SYSTEM	01-000-TOC
02-000-TOC	AXLES	02-000-TOC
03-000-TOC	STEERING SYSTEM	03-000-TOC
04-000-TOC	DRIVE TRAIN SYSTEM	04-000-TOC
05-000-TOC	COMPRESSED AIR SYSTEM	05-000-TOC
06-000-TOC	HYDRAULIC SYSTEM	06-000-TOC
07-000-TOC	ELECTRICAL SYSTEM	07-000-TOC
08-000-TOC	CAB	08-000-TOC
09-000-TOC	CHASSIS	09-000-TOC
10-000-TOC	WHEELS	10-000-TOC
11-000-TOC	IMPLEMENT LIFT SYSTEM FRONT	11-000-TOC
12-000-TOC	IMPLEMENT LIFT SYSTEM REAR	12-000-TOC
13-000-TOC	FRONT/REAR LOADERS	13-000-TOC
14-000-TOC	ATTACHMENTS	14-000-TOC
15-000-TOC	ACCESSORIES	15-000-TOC

FARMER 304 (158/00001-03500)
2566



2566

Item	Part Number	Qty	Description Comments	Technical Specification
			--> 158/2468	
1	72348075	1	RADIATOR RANGE OF TEMPERATURE 1 ><1-3	
	72348099	1	RADIATOR RANGE OF TEMPERATURE 2 ><1-3	
2	72478248	1	COLLER LOCKING	
3	72436028	1	HOSE	L=1500FWN65912-10X2-PVC-W-G
4	72393668	1	FAN COVER	
5	72315818	4	SCREW	DIN7976-ST4,2X25-C-A3L
	72315787	2	SCREW	DIN 7981 B4,2X16-A3L
6	72311817	6	DISC	DIN9021-4,3-140HV-A3L
7	72379109	2	MARKING PLATE	FWN66556-35X68-SCHUTZVORR.N.OE
8	72315660	1	HEXAGONAL HEAD BOLT	DIN 933 M8X35-8.8A3L
9	72311888	2	DISC	
10	72310718	2	BUSH	
11	72312479	4	UNIVERSAL SPOUT	
12	72311788	3	DISC	DIN 125-8,4-ST.A3L
13	72311788	1	DISC	DIN 125-8,4-ST.A3L
14	72315053	6	SPLIT WASHER	FWN 65208-8-A3L
15	72315650	4	HEXAGONAL HEAD BOLT	DIN 933 M8 X 20-8.8A3L
16	72313268	5	NUT	DIN 934 M8-8A3L
17	72393671	2	BRACE	
18	72378063	1	RELIEF VALVE	DIN71401-CM14X1,5KEG
19	72438345	1	HOSE CLIP	
20	72389310	1	HOSE	
21			SEE ENGINE BLOWER	
22			SEE ENGINE BLOWER	
23			SEE ENGINE BLOWER	
24			SEE ALTERNATOR ASSY	
25			SEE ENGINE BLOWER	
26			SEE ENGINE BLOWER	
27			SEE ENGINE BLOWER	
28			SEE ENGINE BLOWER	
29			SEE ENGINE BLOWER	
30			SEE ENGINE BLOWER	
31			SEE CRANKCASE	
32	72393670	1	RUBBER ARCH	
33	72311167	2	HOSE CLIP	
34	72380193	1	THERMOSTAT	75GR+-2GR
35	72393666	1	RUBBER ARCH	
36	72450416	1	HOSE 1X 50MM CUT TO LENGTH	L=120 DIN73411-35X
37	72311162	8	HOSE CLIP	
38	72354912	1	COOLING WATER SUPPLY LINE	
39	72329731	3	RUBBER ARCH	
40	72311167	6	HOSE CLIP	
41	72315802	1	SCREW NOT NEEDED WITH HEATING	DIN 7604 AM22X1,5-ST
42	72315101	1	SEALING WASHER NOT NEEDED WITH HEATING	DIN 7603 A22X27-CU

Item	Part Number	Qty	Description Comments	Technical Specification
43	72356699	1	SUCTION LINE --> 158/2000	
	72356702	1	SUCTION LINE <-- 158/2001	
44	72450416	1	HOSE 1X 60MM CUT TO LENGTH --> 158/2000	L=120 DIN73411-35X
	72395412	1	RUBBER ARCH <-- 158/2001	
45	72450416	1	HOSE 1X 60MM CUT TO LENGTH --> 158/2000	L=120 DIN73411-35X
	72393672	1	REDUCER <-- 158/2001	
46	72315802	1	SCREW NOT NEEDED WITH HEATING --> 158/2000	DIN 7604 AM22X1,5-ST
	72404925	1	CAP NOT NEEDED WITH HEATING <-- 158/2001	
47	72315101	1	SEALING WASHER NOT NEEDED WITH HEATING --> 158/2000	DIN 7603 A22X27-CU
	72373533	1	HOSE CLIP NOT NEEDED WITH HEATING <-- 158/2001	
49	72337051	1	PIPE CLAMP	
50	72332467	1	PLATE LINK	
51	72315629	1	HEXAGONAL HEAD BOLT	DIN 933 M6 X 12-8.8A3L
52	72315052	1	SPLIT WASHER	FWN 65208-6-A3L
53	72315630	1	HEXAGONAL HEAD BOLT	DIN 933 M6X18-8.8A3L

FARMER 304 (158/00001-03500)
4259

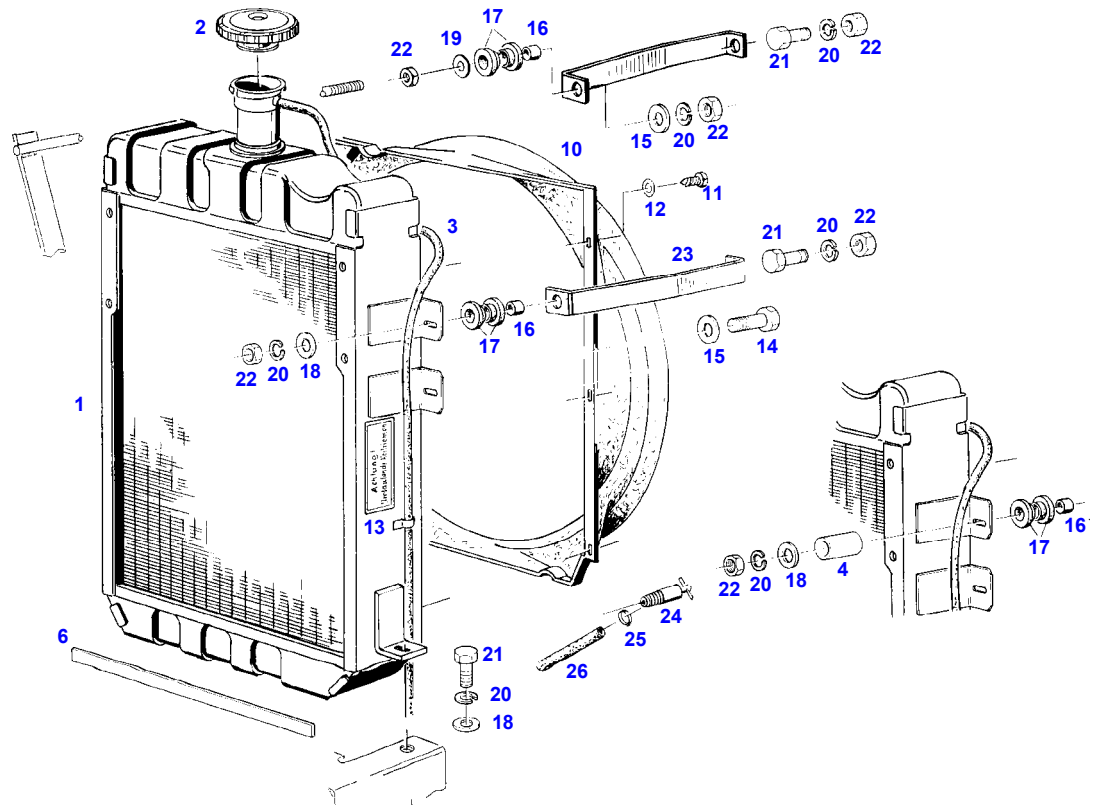

4259

Item	Part Number	Qty	Description Comments	Technical Specification
			RANGE OF TEMPERATURE 1+1 WITH AIR BRAKE SUPPLY EQUIPEMENT <-- 158/2469	
1	72348075	1	RADIATOR ><1-3	
2	72478248	1	COLLER LOCKING	
3	72436028	1	HOSE	L=1500FWN65912-10X2-PVC-W-G
4			NOT USED	
5			NOT USED	
6			NOT USED	
10	72393668	1	FAN COVER	
11	72315818	4	SCREW	DIN7976-ST4,2X25-C-A3L
	72315787	2	SCREW	DIN 7981 B4,2X16-A3L
12	72311817	6	DISC	DIN9021-4,3-140HV-A3L
13	72386100	2	WARNING SIGN D	
	72388085	2	WARNING SIGN GB	
	72388086	2	WARNING SIGN F	
	72388087	2	WARNING SIGN I	
	72388088	2	WARNING SIGN E	
14	72315660	1	HEXAGONAL HEAD BOLT	DIN 933 M8X35-8.8A3L
15	72311888	2	DISC	
16	72310718	2	BUSH	
17	72312479	4	UNIVERSAL SPOUT	
18	72311788	3	DISC	DIN 125-8,4-ST.A3L
19	72311788	1	DISC	DIN 125-8,4-ST.A3L
20	72315053	6	SPLIT WASHER	FWN 65208-8-A3L
21	72315650	4	HEXAGONAL HEAD BOLT	DIN 933 M8 X 20-8.8A3L
22	72313268	5	NUT	DIN 934 M8-8A3L
23	72393671	2	BRACE	
24	72378063	1	RELIEF VALVE	DIN71401-CM14X1,5KEG
25	72438345	1	HOSE CLIP	
26	72389310	1	HOSE	

FARMER 304 (158/00001-03500)
4259

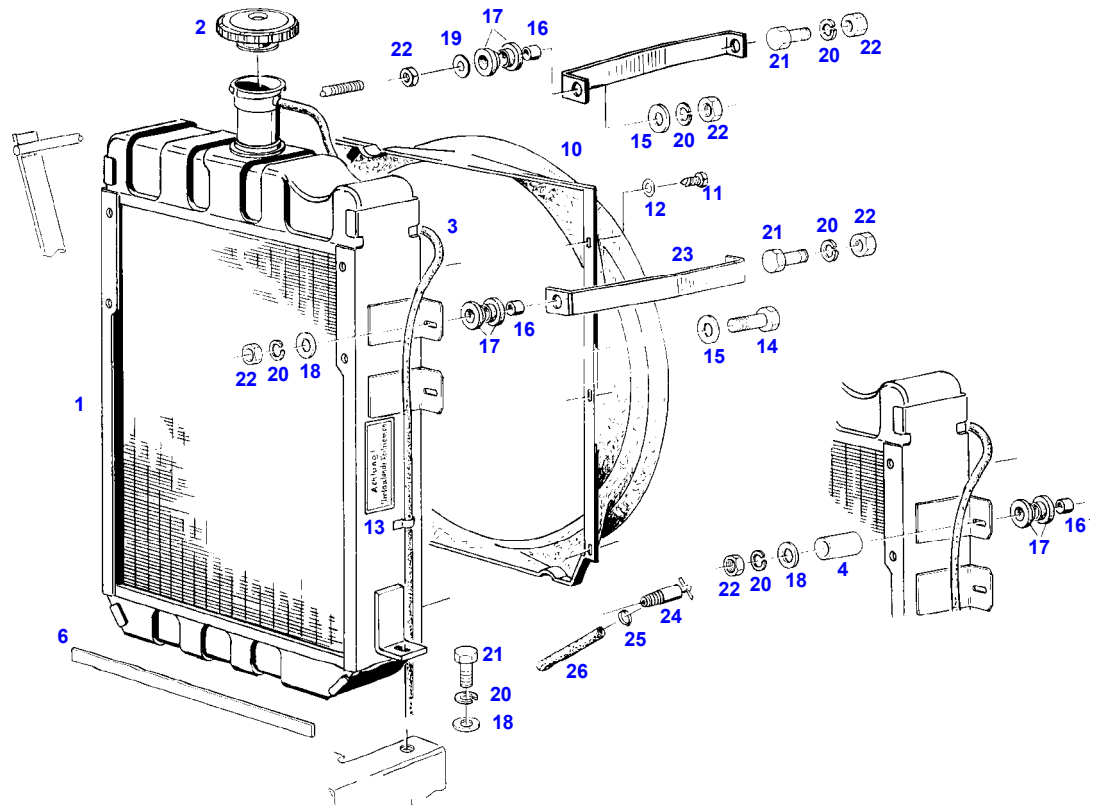

4259

Item	Part Number	Qty	Description Comments	Technical Specification
			RANGE OF TEMPERATURE 2+2 WITH AIR BRAKE SUPPLY EQUIPEMENT <-- 158/2469	
1	72348099	1	RADIATOR ><1-3	
2	72478248	1	COLLER LOCKING	
3	72436028	1	HOSE	L=1500FWN65912-10X2-PVC-W-G
4			NOT USED	
5			NOT USED	
6			NOT USED	
10	72393668	1	FAN COVER	
11	72315818	4	SCREW	DIN7976-ST4,2X25-C-A3L
	72315787	2	SCREW	DIN 7981 B4,2X16-A3L
12	72311817	6	DISC	DIN9021-4,3-140HV-A3L
13	72386100	2	WARNING SIGN D	
	72388085	2	WARNING SIGN GB	
	72388086	2	WARNING SIGN F	
	72388087	2	WARNING SIGN I	
	72388088	2	WARNING SIGN E	
14	72315660	1	HEXAGONAL HEAD BOLT	DIN 933 M8X35-8.8A3L
15	72311888	2	DISC	
16	72310718	2	BUSH	
17	72312479	4	UNIVERSAL SPOUT	
18	72311788	3	DISC	DIN 125-8,4-ST.A3L
19	72311788	1	DISC	DIN 125-8,4-ST.A3L
20	72315053	6	SPLIT WASHER	FWN 65208-8-A3L
21	72315650	4	HEXAGONAL HEAD BOLT	DIN 933 M8 X 20-8.8A3L
22	72313268	5	NUT	DIN 934 M8-8A3L
23	72393671	2	BRACE	
24	72378063	1	RELIEF VALVE	DIN71401-CM14X1,5KEG
25	72438345	1	HOSE CLIP	
26	72389310	1	HOSE	

FARMER 304 (158/00001-03500)
4300

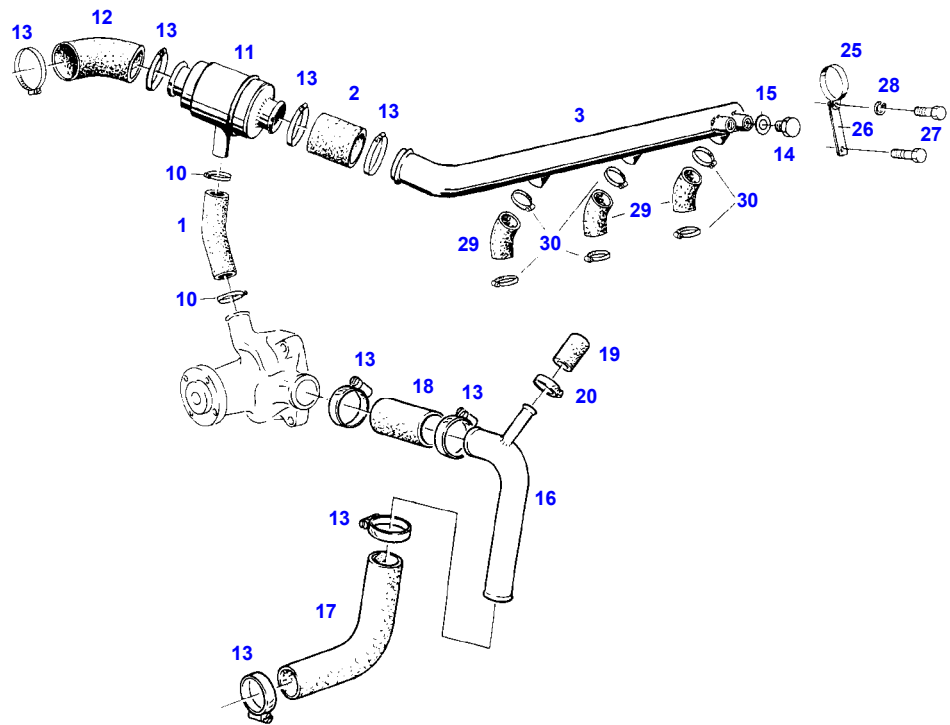

4300

Item	Part Number	Qty	Description Comments	Technical Specification
			RANGE OF TEMPERATURE 1+1 WITH AIR BRAKE SUPPLY EQUIPEMENT RANGE OF TEMPERATURE 2+2 WITH AIR BRAKE SUPPLY EQUIPEMENT <-- 158/2469	
1	72393670	1	RUBBER ARCH	
2	72450416	1	HOSE 1X 50MM CUT TO LENGTH	L=120 DIN73411-35X
3	72354912	1	COOLING WATER SUPPLY LINE	
10	72311167	2	HOSE CLIP	
11	72380193	1	THERMOSTAT	75GR+-2GR
12	72393666	1	RUBBER ARCH	
13	72311162	8	HOSE CLIP	
14	72315802	1	SCREW	DIN 7604 AM22X1,5-ST
15	72315101	1	SEALING WASHER	DIN 7603 A22X27-CU
16	72356702	1	SUCTION LINE	
17	72395412	1	RUBBER ARCH	
18	72393672	1	REDUCER	
19	72404925	1	CAP	
20	72311166	1	HOSE CLIP	
25	72337051	1	PIPE CLAMP	
26	72332467	1	PLATE LINK	
27	72315629	1	HEXAGONAL HEAD BOLT	DIN 933 M6 X 12-8.8A3L
28	72315052	1	SPLIT WASHER	FWN 65208-6-A3L
29	72329731	3	RUBBER ARCH	
30	72311167	6	HOSE CLIP	

FARMER 304 (158/00001-03500)
4267

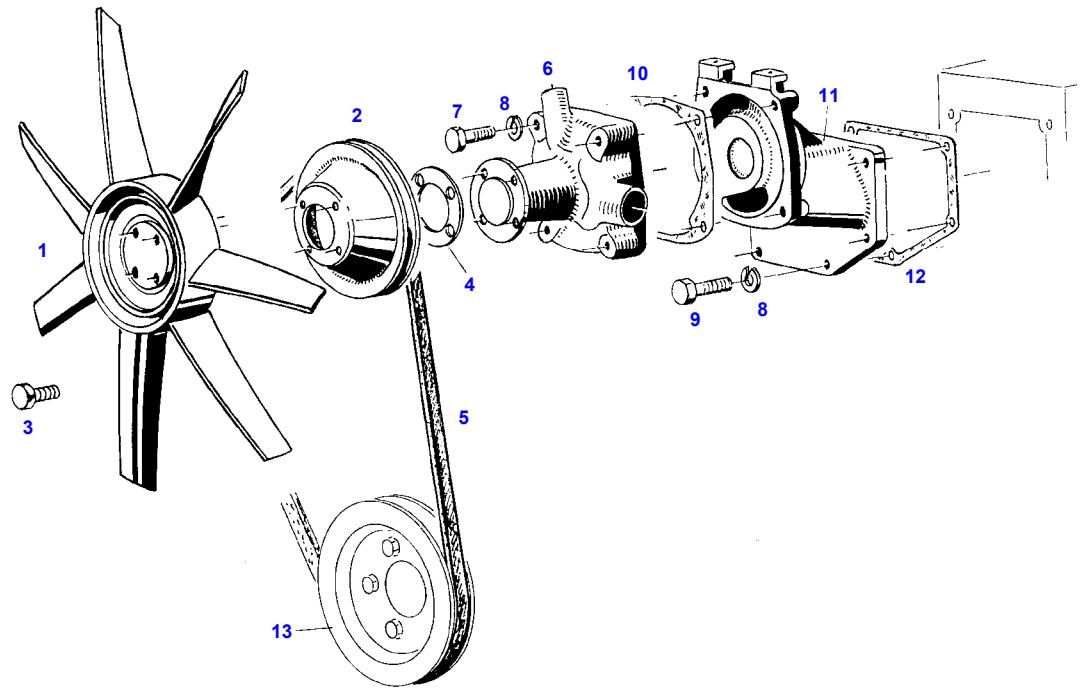

4267

Item	Part Number	Qty	Description Comments	Technical Specification
RANGE OF TEMPERATURE 1				
1	72328674	1	FAN	
2	72327206	1	V BELT SHEAVE	
3	72375063	4	LOCK SCREW	FWN 64993 M8X22-12.9
4	72394835	1	DISC	
5				
6	72340133	1	SEE ALTERNATOR ASSY CENTRIFUGAL PUMP	
	72340135	1	REPAIR KIT <-- F281.200.610.010 1X	
7	72315659	4	HEXAGONAL HEAD BOLT	DIN 933 M8X35-8.8
8	72315053	10	SPLIT WASHER	FWN 65208-8-A3L
9	72315654	6	HEXAGONAL HEAD BOLT	DIN 933 M8X28-8.8A3L
10	72328678	1	SEAL	
11	72330788	1	INTERMEDIATE PIECE <-- F162.204.610.010	
12			SEE CRANKCASE	
13			SEE CRANKSHAFT	

FARMER 304 (158/00001-03500)
4267

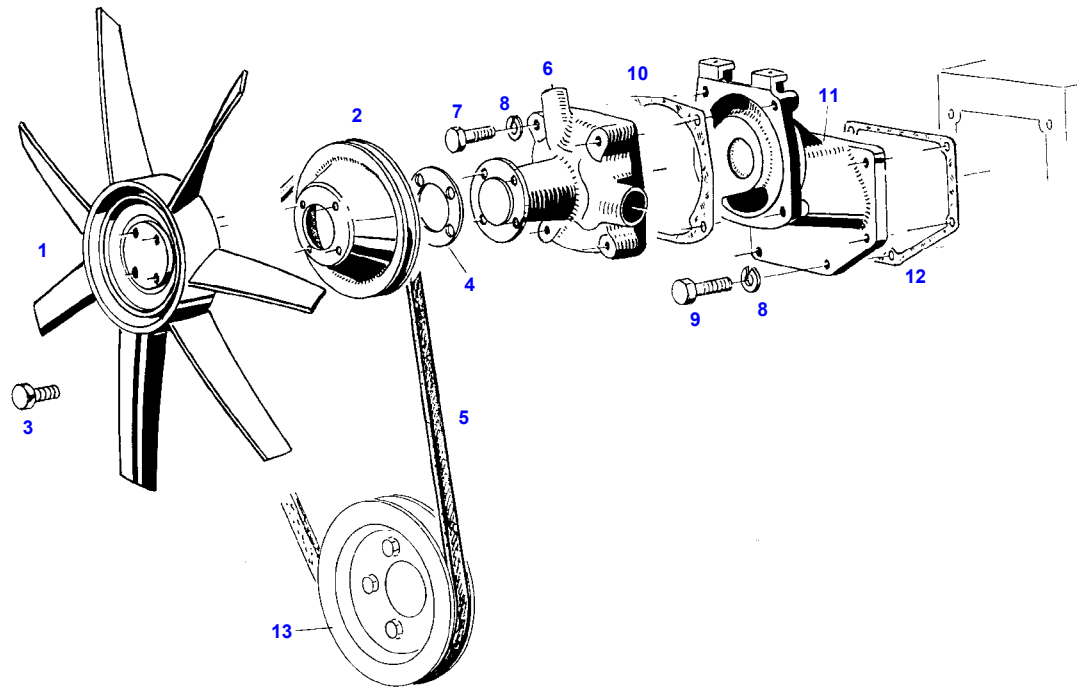

4267

Item	Part Number	Qty	Description Comments	Technical Specification
			RANGE OF TEMPERATURE 2	
1	72380201	1	FAN	SAUG.440/7
2	72399923	1	V BELT SHEAVE	
3	72375067	4	LOCK SCREW	FWN 64993 M8X35-90
4				
5			NOT USED	
			SEE ALTERNATOR ASSY	
6	72340133	1	CENTRIFUGAL PUMP	
	72340135	1	REPAIR KIT	
			<-- F281.200.610.010 1X	
7	72315659	4	HEXAGONAL HEAD BOLT	DIN 933 M8X35-8.8
8	72315053	10	SPLIT WASHER	FWN 65208-8-A3L
9	72315654	6	HEXAGONAL HEAD BOLT	DIN 933 M8X28-8.8A3L
10	72328678	1	SEAL	
11	72330788	1	INTERMEDIATE PIECE	
			<-- F162.204.610.010	
12			SEE CRANKCASE	
13			SEE CRANKSHAFT	

FARMER 304 (158/00001-03500)
11160

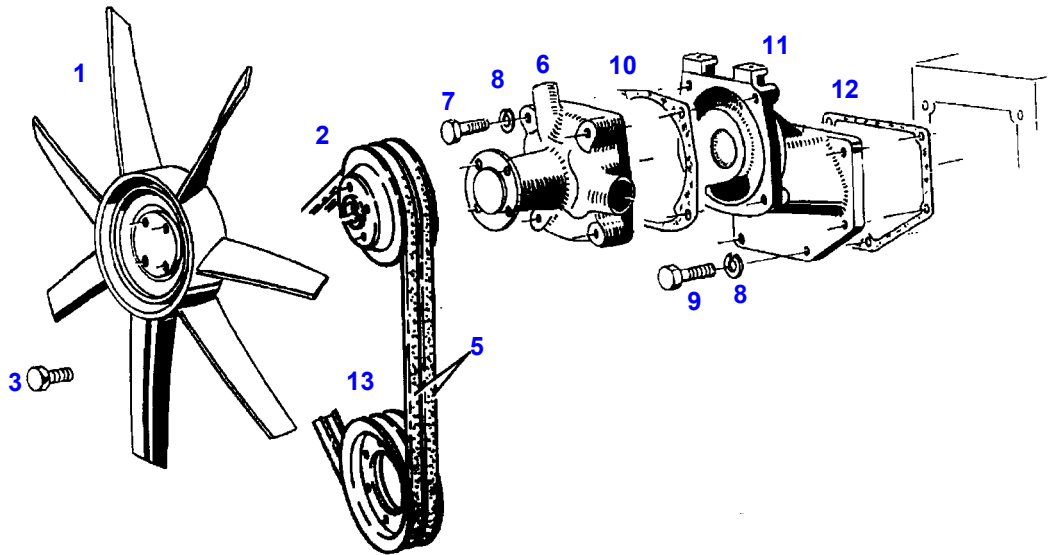

01160

Item	Part Number	Qty	Description Comments	Technical Specification
			AIR BRAKIN SYSTEM --> 158/2468	
1	72328674	1	FAN	
2	72393674	1	V BELT SHEAVE	
3	72375066	4	LOCK SCREW	FWN 64993-M8X30-90
5				
			SEE COMPRESSOR INSTALLAT	
6	72340133	1	CENTRIFUGAL PUMP	
	72340135	1	REPAIR KIT	
			<-- F281.200.610.010 1X	
7	72315659	4	HEXAGONAL HEAD BOLT	DIN 933 M8X35-8.8
8	72315053	10	SPLIT WASHER	FWN 65208-8-A3L
9	72315654	6	HEXAGONAL HEAD BOLT	DIN 933 M8X28-8.8A3L
10	72328678	1	SEAL	
11	72330788	1	INTERMEDIATE PIECE	
			<-- F162.204.610.010	
12				
			SEE CRANKCASE	
13				
			SEE COMPRESSOR INSTALLAT	

FARMER 304 (158/00001-03500)
11160

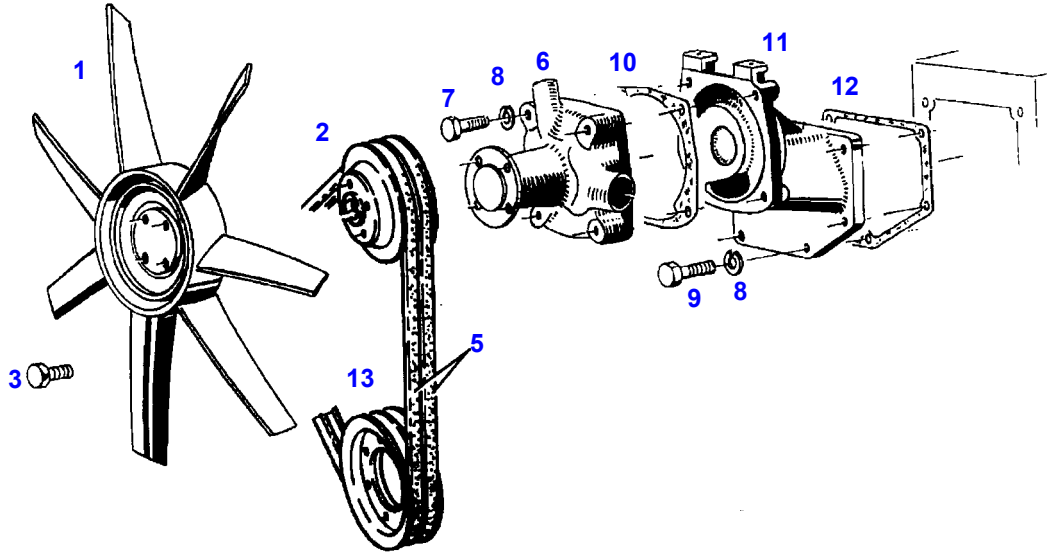

01160

Item	Part Number	Qty	Description Comments	Technical Specification
			AIR BRAKIN SYSTEM <-- 158/2469	
1	72328674	1	FAN	
2	72393674	1	V BELT SHEAVE	
			RANGE OF TEMPERATURE 1	
	72394220	1	V BELT SHEAVE	
			RANGE OF TEMPERATURE 2	
3	72375066	4	LOCK SCREW	FWN 64993-M8X30-90
5			SEE COMPRESSOR INSTALLAT	
6	72340133	1	CENTRIFUGAL PUMP	
	72340135	1	REPAIR KIT	
			<-- F281.200.610.010 1X	
7	72315659	4	HEXAGONAL HEAD BOLT	DIN 933 M8X35-8.8
8	72315053	10	SPLIT WASHER	FWN 65208-8-A3L
9	72315654	6	HEXAGONAL HEAD BOLT	DIN 933 M8X28-8.8A3L
10	72328678	1	SEAL	
11	72330788	1	INTERMEDIATE PIECE	
			<-- F162.204.610.010	
12			SEE CRANKCASE	
13			SEE COMPRESSOR INSTALLAT	

Item	Part Number	Qty	Description Comments	Technical Specification
			--> 158/0592	
1	72348236	1	FUEL TANK <>	
	72348556	1	FUEL LEVEL SENSOR	
2	72380019	1	STRAINER --> 158/0345	
	72433112	1	STRAINER <-- 158/0346	60X100-MS
3	72348405	1	FUEL CAP ><4-5 BLAU <-- X810.110.050 1X	
	72348297	1	FUEL CAP ><4-5 LOCKABLE BLAU	
4	72330725	1	SEAL 2,5MM BLAU	
	72312304	1	RUBBER SEAL KOEHLER	
5	72330726	1	SEAL 0,5MM BLAU	
6	72613041	1	FUEL LEVEL SENSOR ><7	
7	72315169	1	SEALING WASHER	
8	72355536	1	TANK FRAME	
9	72315626	9	HEXAGONAL HEAD BOLT	DIN 933-M6 X 16-8.8-A3L
10	72311822	16	DISC	DIN9021-6,4-140HV-A3L
11	72315052	9	SPLIT WASHER	FWN 65208-6-A3L
12	72313266	9	NUT	DIN 934 M6-8A3L
13	72315719	2	HEXAGONAL HEAD BOLT	DIN 933 M12X60-8.8A3L
14	72313325	2	NUT	DIN 980-VM12-8-A3L
15	72355440	1	BRACKET	
16	72355441	1	BRACKET	
17	72356758	4	SUPPORT ARM <>	
	72313268	1	NUT	DIN 934 M8-8A3L
	72393683	1	ANGLE	
	72315653	1	HEXAGONAL HEAD BOLT	DIN 933 M8 X 25-8.8A3L
	72311788	1	DISC	DIN 125-8,4-ST.A3L
18	72310644	4	RUBBER BUSHING	
19	72407288	1	BEARING PIN	
20	72311183	1	HAIR COTTER PIN	DIN 11024-4-A3L
21	72393676	1	BEARING PIN	
22	72393677	1	RETAINING BRACKET	
23	72393680	1	LEAF SPRING	
24	72355727	1	CROSSMEMBER	
25	72315642	8	HEXAGONAL HEAD BOLT	DIN 933 M8 X 16-8.8A3L
26	72315653	8	HEXAGONAL HEAD BOLT	DIN 933 M8 X 25-8.8A3L
27	72315053	16	SPLIT WASHER	FWN 65208-8-A3L
28	72313268	4	NUT	DIN 934 M8-8A3L
29	72311788	2	DISC	DIN 125-8,4-ST.A3L
30	72315675	2	HEXAGONAL HEAD BOLT	DIN 933 M10X16-8.8A3L

FARMER 304 (158/00001-03500)
5449

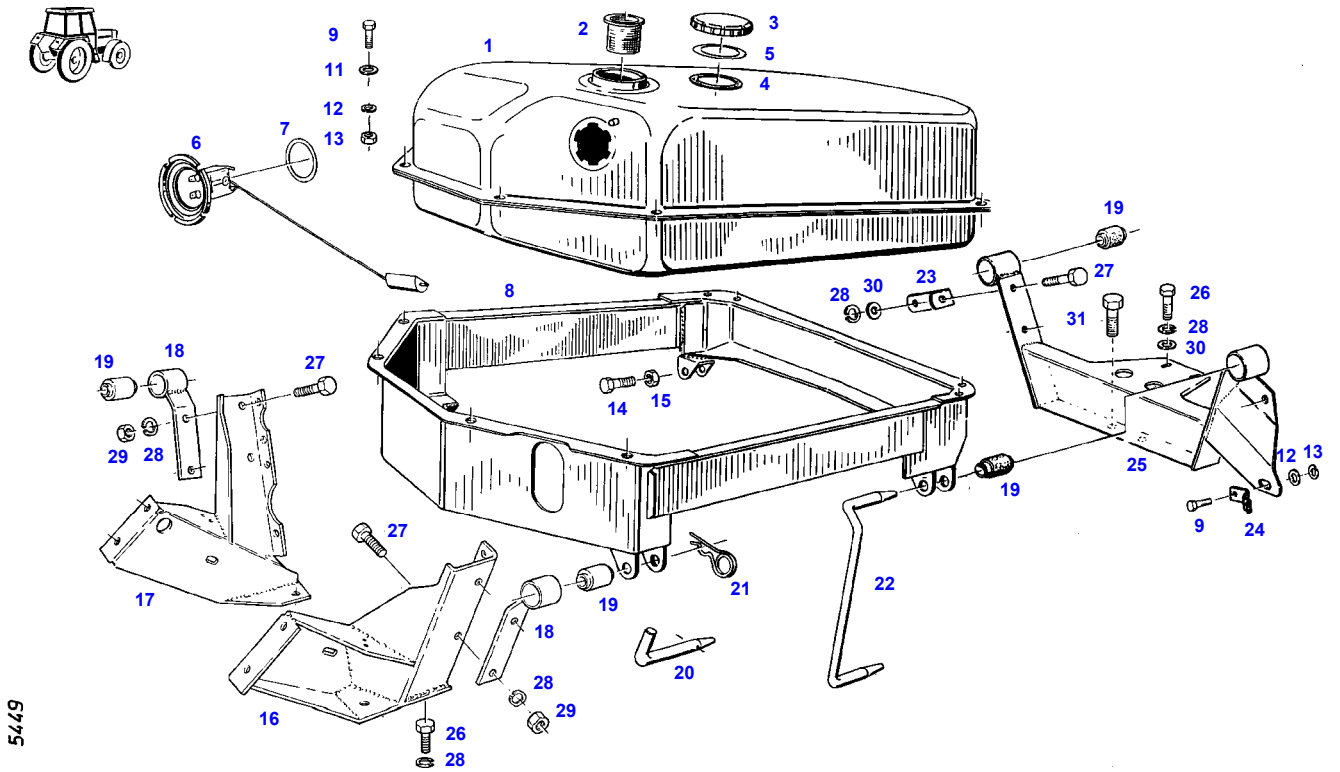

5449

Item	Part Number	Qty	Description Comments	Technical Specification
			<-- 158/0593	
1	72348236	1	FUEL TANK <>	
	72348556	1	FUEL LEVEL SENSOR	
2	72433112	1	STRAINER	60X100-MS
3	72380143	1	FUEL CAP KOEHLER ><4	M.BELUEF
	72348297	1	FUEL CAP LOCKABLE BLAU ><4-5	
4	72330725	1	SEAL BLAU 2,5MM	
	72312304	1	RUBBER SEAL KOEHLER	
5	72330726	1	SEAL BLAU 0,5MM	
6	72613041	1	FUEL LEVEL SENSOR ><6+7	
7	72315169	1	SEALING WASHER	
8	72355536	1	TANK FRAME	
9	72315626	9	HEXAGONAL HEAD BOLT	DIN 933-M6 X 16-8.8-A3L
	72315631	2	HEXAGONAL HEAD BOLT	DIN 933 M6 X 20-8.8A3L
11	72311822	16	DISC	DIN9021-6,4-140HV-A3L
12	72315052	9	SPLIT WASHER	FWN 65208-6-A3L
13	72313266	9	NUT	DIN 934 M6-8A3L
14	72315719	2	HEXAGONAL HEAD BOLT	DIN 933 M12X60-8.8A3L
15	72313325	2	NUT	DIN 980-VM12-8-A3L
16	72355441	1	BRACKET	
17	72355440	1	BRACKET	
18	72356758	2	SUPPORT ARM	
19	72310644	4	RUBBER BUSHING	
20	72404932	1	BEARING PIN	
21	72311183	1	HAIR COTTER PIN	DIN 11024-4-A3L
22	72393676	1	BEARING PIN	
23	72393683	1	ANGLE	
24	72393680	1	LEAF SPRING	
25	72355727	1	CROSSMEMBER	
26	72315642	8	HEXAGONAL HEAD BOLT	DIN 933 M8 X 16-8.8A3L
27	72315653	5	HEXAGONAL HEAD BOLT	DIN 933 M8 X 25-8.8A3L
28	72315053	13	SPLIT WASHER	FWN 65208-8-A3L
29	72313268	4	NUT	DIN 934 M8-8A3L
30	72311788	3	DISC	DIN 125-8,4-ST.A3L
31	72315675	2	HEXAGONAL HEAD BOLT	DIN 933 M10X16-8.8A3L

FARMER 304 (158/00001-03500)
5450

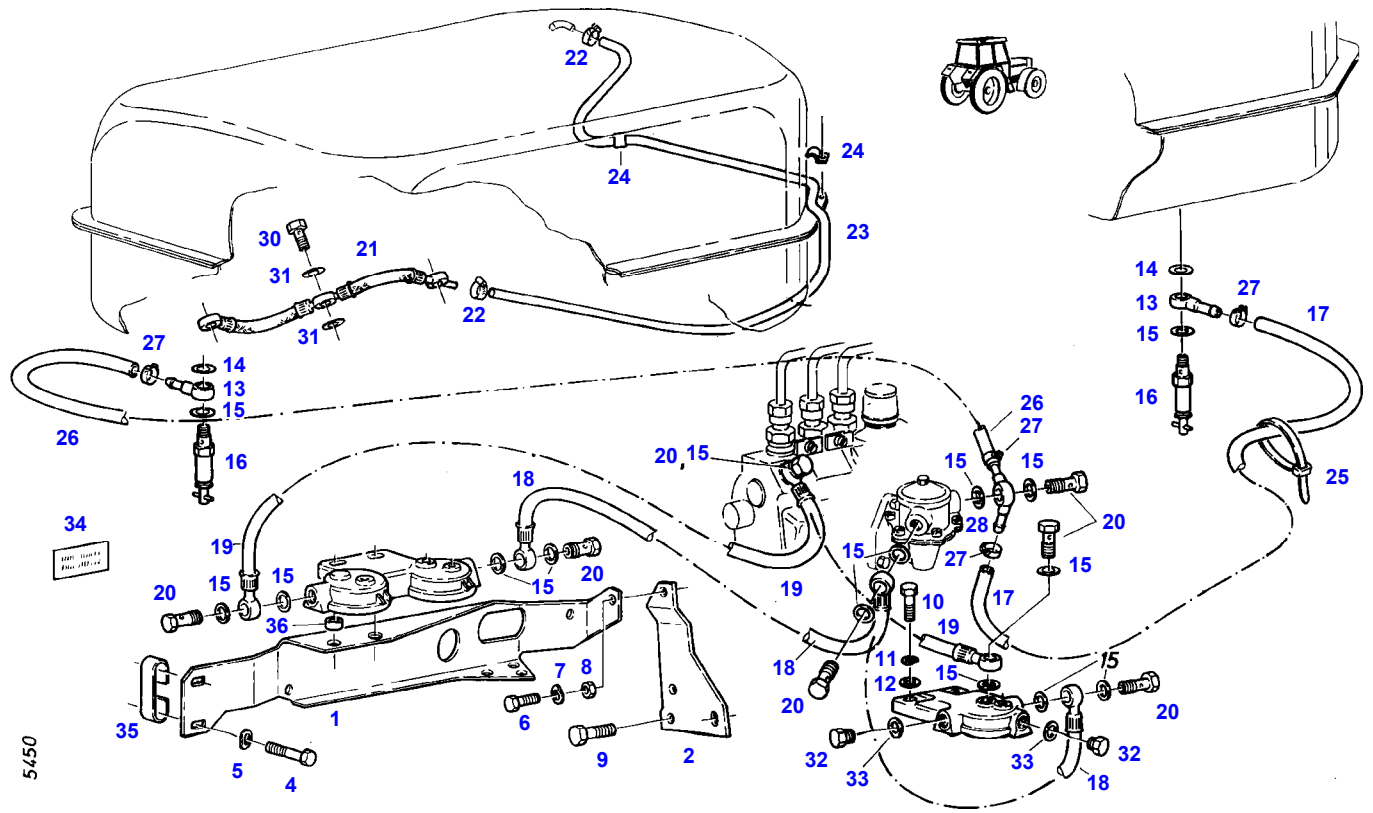

5450

Item	Part Number	Qty	Description Comments	Technical Specification
1	72354920	1	FILTER RETAINER	
2	72393679	1	RETAINING SHEET METAL	
4	72315675	1	HEXAGONAL HEAD BOLT	DIN 933 M10X16-8.8A3L
	72315679	1	HEXAGONAL HEAD BOLT	DIN 933 M10X20-8.8A3L
	72315689	1	HEXAGONAL HEAD BOLT	DIN 933 M10X35-8.8A3L
	72315691	1	HEXAGONAL HEAD BOLT	DIN 933 M10X40-8.8A3L
5	72317122	2	SPRING WASHER	DIN 137 B10-MECH.VZK
6	72315642	1	HEXAGONAL HEAD BOLT	DIN 933 M8 X 16-8.8A3L
7	72315053	1	SPLIT WASHER	FWN 65208-8-A3L
8	72313268	1	NUT	DIN 934 M8-8A3L
9	72374490	2	HEXAGONAL HEAD BOLT	DIN 933 M14X20-8.8
10	72315685	2	HEXAGONAL HEAD BOLT	DIN 933 M10X30-8.8A3L
			SINGLE FILTER	
	72315691	2	HEXAGONAL HEAD BOLT	DIN 933 M10X40-8.8A3L
			PARALLEL-FILTER	
11	72315054	2	SPLIT WASHER	FWN 65208-10-A3L
12	72311789	2	DISC	DIN 125-10,5-ST.A3L
13	72377531	2	RING HOSE NIPPLE	FWN65910-A-DN8
14	72315093	2	SEALING WASHER	DIN 7603 A12X18-CU
15	72315095	12	SEALING WASHER	DIN 7603 A14X20-CU
16	72380159	2	FUEL SHUT-OFF VALVE	
17	72450303	1	PRESSURE HOSE	L=1000
			980 MM	
			CUT TO LENGTH	
18	72356760	1	FUEL LINE	
19	72355537	1	FUEL LINE	
20	72315808	5	BANJO BOLT	DIN 7643-10-3-A3L
21	72334904	1	LEAKAGE OIL LINE	
22	72438345	4	HOSE CLIP	
23	72378086	1	PRESSURE HOSE	FWN 66041-P4
24	72398941	2	FASTENING COLLAR	
25	72316916	2	CABLE STRAP	FWN 66650 B175X4-SW
26	72450303	1	PRESSURE HOSE	L=1000
			880 MM	
			CUT TO LENGTH	
27	72438345	2	HOSE CLIP	
28	72377533	1	DOUBLE NIPPLE	FWN65910-DN8-120GR
30	72315809	3	BANJO BOLT	DIN 7643-4-5-A3L
31	72315086	6	SEALING WASHER	DIN 7603 A8X11,5-CU
32	72315799	2	PLUG	DIN 7604 AM14X1,5-A3L
33	72315095	2	SEALING WASHER	DIN 7603 A14X20-CU
34	72393682	1	MARKING PLATE	
			ARABIAN-ENGLISH	
35	72399913	1	HOLDER	
36	72400157	2	BUSH	

FARMER 304 (158/00001-03500)
4952

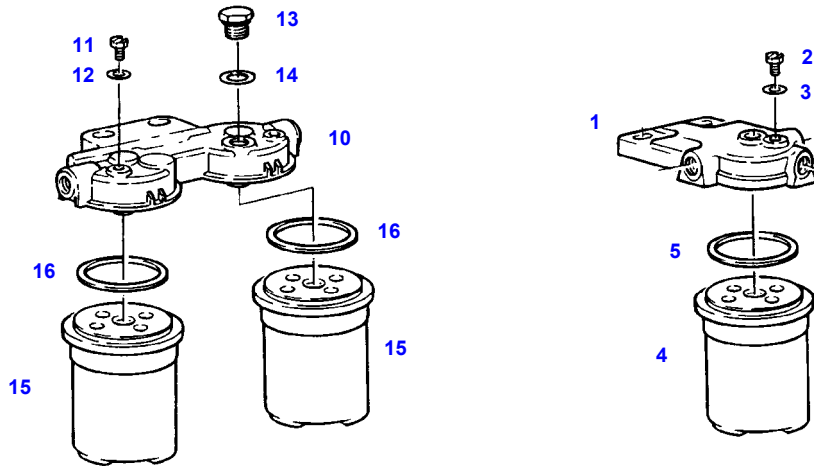

4952

Item	Part Number	Qty	Description Comments	Technical Specification
1	72615599	1	FILTER LID ><2,3	
2	72323290	1	BLEED SCREW	
3	72315084	1	SEALING WASHER	DIN 7603 A6X10-CU
4	72416928	1	FILTER BOX ><5	
5	72314995	1	RUBBER RING PARALLEL-FILTER	
10	72380173	1	PARALLEL FILTER BOSCH ><11-16 <-- X810.190.166.000 1X <>	
	72416928	2	FILTER BOX	
	72451307	1	COVER KNECHT ><11-12 <>	PARALLELFILT.
	72416928	2	FILTER BOX	
11	72323290	2	BLEED SCREW BOSCH	
	72314699	2	BLEED SCREW KNECHT	
12	72315084	2	SEALING WASHER BOSCH	DIN 7603 A6X10-CU
	72315086	2	SEALING WASHER KNECHT	DIN 7603 A8X11,5-CU
13	72326250	1	SCREW BOSCH	
14	72315095	1	SEALING WASHER BOSCH	DIN 7603 A14X20-CU
15	72416928	2	FILTER BOX ><16	
16	72314995	2	RUBBER RING	
18	72380174	2	SCREW NOT ILLUSTRATED	

FARMER 304 (158/00001-03500)
2567

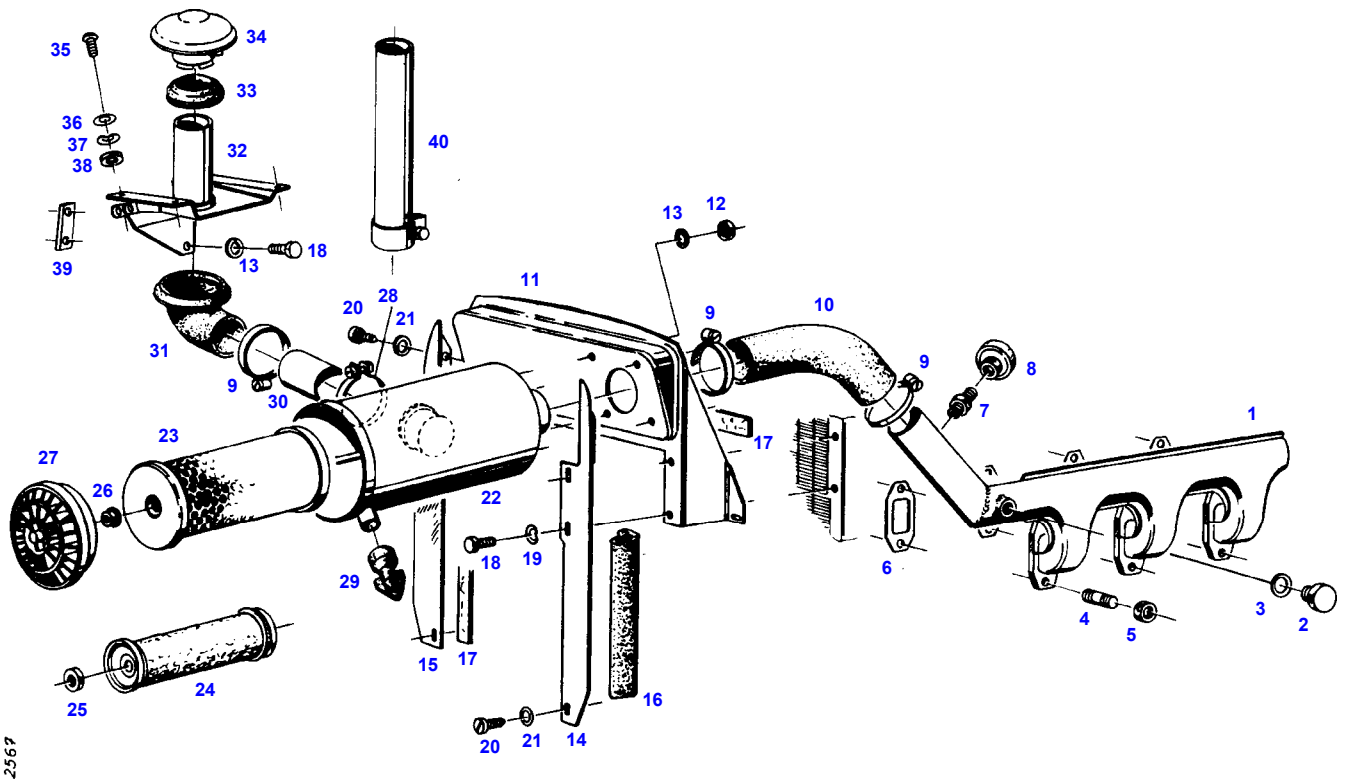

2567

Item	Part Number	Qty	Description Comments	Technical Specification
1	72354921	1	INTAKE MANIFOLD	
	72354922	1	INTAKE MANIFOLD AIR BRAKING SYSTEM	
2	72373975	1	SCREW	DIN 910 M20X1,5-ST
3	72376031	1	SEALING WASHER	DIN 7603 A20X24-CU
4	72373922	6	STUD BOLT	DIN 835-M10X25-8.8
5	72373015	6	NUT	DIN70615-M10-8-A3B
6	72332145	3	MOLDED SEAL	
7	72339032	1	THREADED SOCKET --> 158/2634	
8	72379888	1	MAINTENANCE SWITCH MANN + HUMMEL --> 158/2000 <>	
	72379171	1	WIRE	B1 DIN72551/6.51 SCHWARZ
	72380356	0	CABLE LUG	
	72380356	0	CABLE LUG	
	72314686	1	PLUG IN SLEEVE	
	72316876	1	MAINTENANCE SWITCH MANN + HUMMEL <-- 158/2001 <>	
	72379896	1	MAINTENANCE SWITCH KNECHT <-- 158/2001 <>	
9	72373528	3	HOSE CLIP	
10	72393689	1	RUBBER ARCH	
11	72392142	1	FILTER BRACKET <>	
	72311787	1	DISC	DIN 125-6,4-ST.A3L
	72313266	1	NUT	DIN 934 M6-8A3L
	72314744	1	LOCKING PLUG	F4
	72315052	6	SPLIT WASHER	FWN 65208-6-A3L
	72315626	1	HEXAGONAL HEAD BOLT	DIN 933-M6 X 16-8.8-A3L
12	72313268	4	NUT	DIN 934 M8-8A3L
13	72315053	6	SPLIT WASHER	FWN 65208-8-A3L
14	72392834	1	SPLASH PANEL	
15	72392835	1	SPLASH PANEL	
16	72393692	1	SEALING PROFILE	
17			NO SPARE PART	
18	72315645	6	HEXAGONAL HEAD BOLT	DIN 933 M8 X 12-8.8A3L
19	72317121	4	SPRING WASHER	DIN 137 B8-MECH.VZK
20	72315785	4	SCREW	DIN 7981 ST4,2X9,5-C-H-A3
21	72311817	4	DISC	DIN9021-4,3-140HV-A3L
22	72348100	1	AIR FILTER ><22-29	
	72329111	1	DIFFUSER	
23	72329734	1	MICRO-TOP CARTRIDGE	
24	72329735	1	SAFETY CARTRIDGE	
25	72372827	1	NUT	DIN 934 M16X1,5-10A3L
26	72339030	1	COLLAR NUT	
27	72329736	1	FLOOR	
28	72329737	1	PIPE CLAMP <-- X458.648.500.000	
29	72326122	1	DUST DISCHARGE VALVE	
30	72393687	1	CONNECTING PIPE	
31	72393688	1	BELLOWS	
32	72355730	1	AIR INTAKE	
33	72393690	1	SEALING RING	
34	72330730	1	RAIN CAP	
35	72373806	4	TRUSS HEAD SCREW	DIN 603 M6X16-A3L
36	72311788	4	DISC	DIN 125-8,4-ST.A3L
	72311787	4	DISC	DIN 125-6,4-ST.A3L
37	72315052	4	SPLIT WASHER	FWN 65208-6-A3L

Fendt

FARMER 304 (158/00001-03500)

F158000

AIR FILTER

Page01-0016

Item	Part Number	Qty	Description Comments	Technical Specification
38	72313266	4	NUT	DIN 934 M6-8A3L
39	72393790	1	THREADED PLATE	
40			NO LONGER AVAILABLE	

FARMER 304 (158/00001-03500)
2568

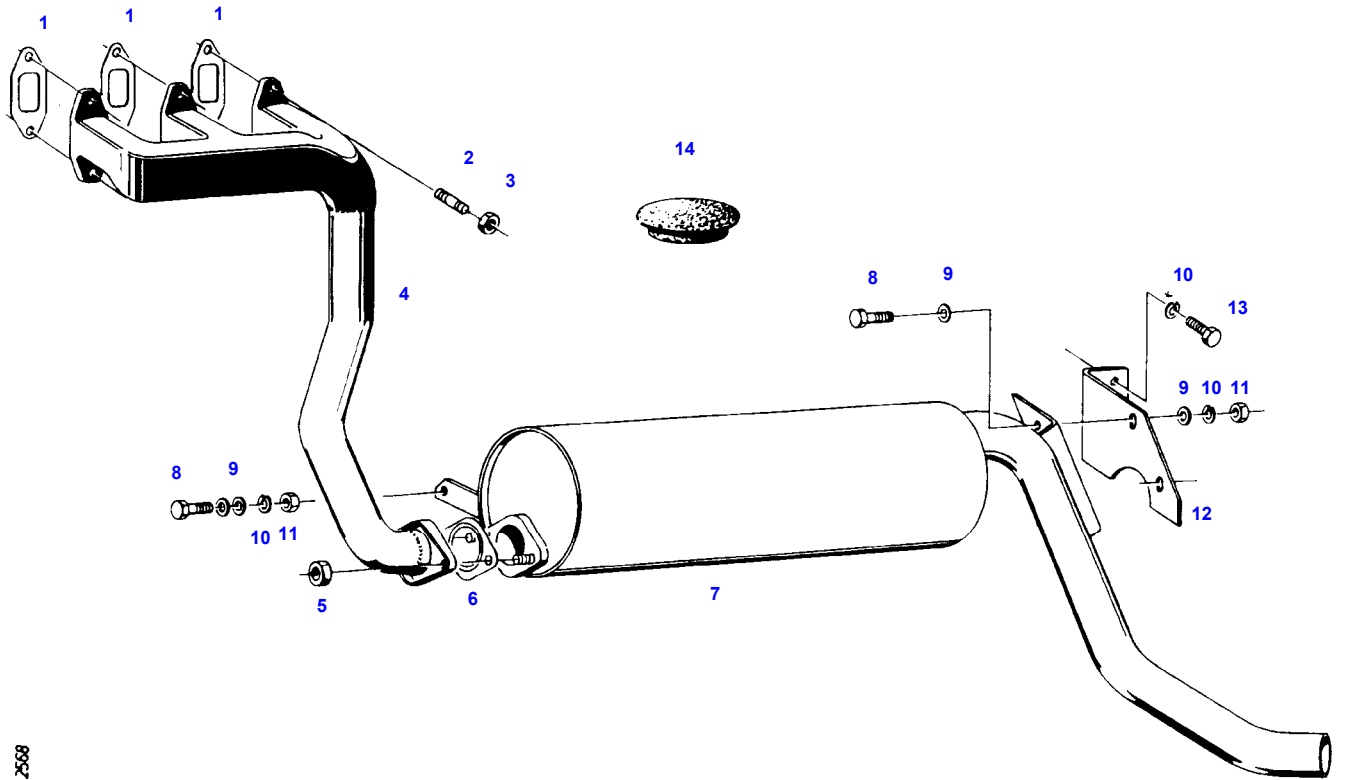

2568

Item	Part Number	Qty	Description Comments	Technical Specification
1	72332145	3	MOLDED SEAL	
2	72313777	6	STUD BOLT	DIN 939 M10X35-8.8
3	72313272	6	NUT	DIN 934 M10-8A3L
4	72353218	1	EXHAUST COLLECTING PIPE	
5	72373015	2	NUT	DIN70615-M10-8-A3B
6	72376173	1	SEAL	DIN71511-56X82X1,5-ST AFM5M.E.
7	72354925	1	EXHAUST MUFFLER	
8	72315646	3	HEXAGONAL HEAD BOLT	DIN 933 M8X18-8.8A3L
9	72311788	6	DISC	DIN 125-8,4-ST.A3L
10	72315053	5	SPLIT WASHER	FWN 65208-8-A3L
11	72313268	3	NUT	DIN 934 M8-8A3L
12	72396312	1	RETAINING BRACKET	
13	72315642	2	HEXAGONAL HEAD BOLT	DIN 933 M8 X 16-8.8A3L
14	72395945	1	COVER	

FARMER 304 (158/00001-03500)
5417

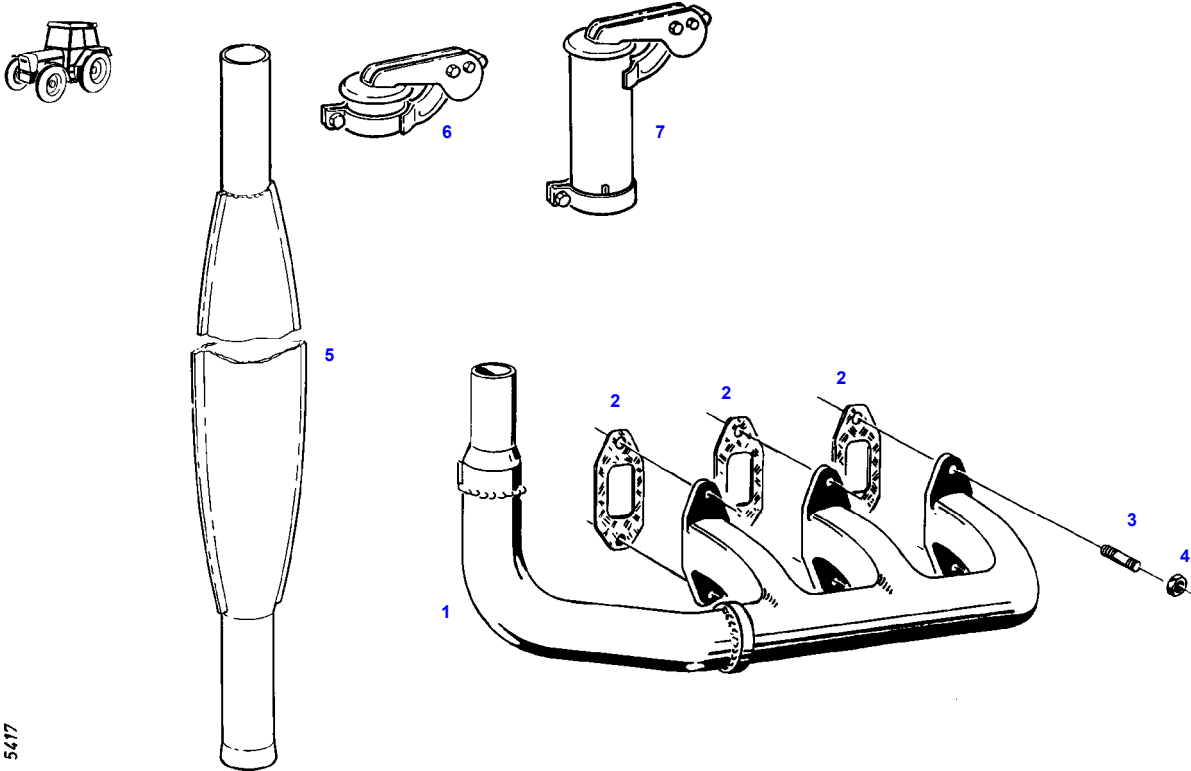

5417

Item	Part Number	Qty	Description Comments	Technical Specification
1	72354926	1	EXHAUST COLLECTING PIPE	
2	72332145	3	MOLDED SEAL	
3	72313776	6	STUD BOLT	DIN 939 M10X25-8.8
4	72373015	6	NUT	DIN70615-M10-8-A3B
5	72359347	1	EXHAUST MUFFLER	
	72358126	1	EXHAUST MUFFLER SWITZERLAND	
	72354927	1	SPARK ARRESTER AUSTRALIA	
6	72347590	1	EXHAUST WEATHER CAP	
7	72383243	1	EXHAUST EXTENSION ><6 CABIN-ROOF HIGH	

FARMER 304 (158/00001-03500)
12076

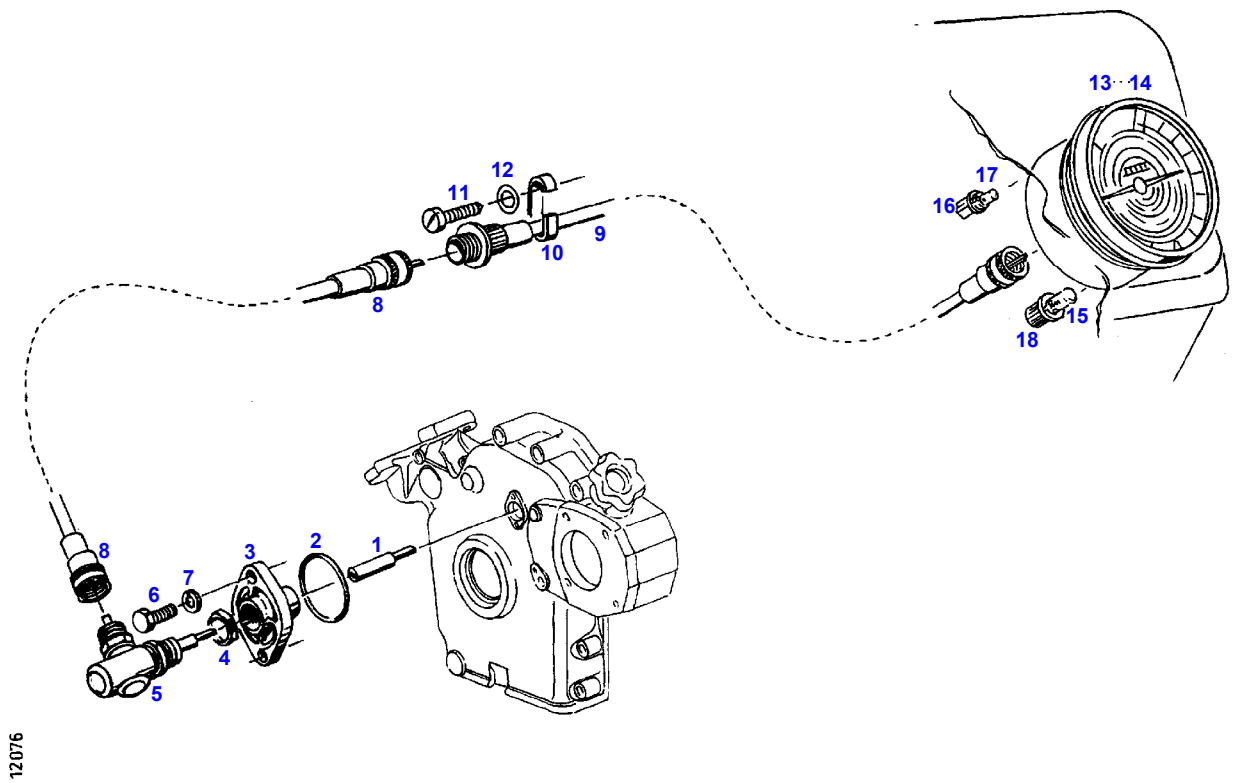

12076

Item	Part Number	Qty	Description Comments	Technical Specification
1	72327035	1	DRIVER	
2	72376543	1	O-RING	42X3-NBR 70 FWN56402
3	72335527	1	COVER	
4	72322566	1	NUT	
5	72334005	1	BEVEL GEAR SYSTEM	
6	72315650	2	HEXAGONAL HEAD BOLT	DIN 933 M8 X 20-8.8A3L
7	72317121	2	SPRING WASHER	DIN 137 B8-MECH.VZK
8	72483595	1	DRIVE SHAFT	
9	72379885	1	DRIVE SHAFT	630 LG
10	72393703	1	HOLDER	
11	72315822	1	SCREW	DIN7976-ST6,3X38-C-A3L
12	72311787	1	DISC	DIN 125-6,4-ST.A3L
13			NO LONGER AVAILABLE ><13,14 2-STAGE SPLITTER --> 158/2000 <-- X800.290.039.000 1X	
	72379854	1	INSTRUMENT CLUSTER ><13,14 3-STAGE SPLITTER <-- 158/2001	T96
	72379842	1	TRACTOMETER 2-STAGE SPLITTER --> 158/2000 NOT ILLUSTRATED	
	72379858	1	TRACTOMETER 3-STAGE SPLITTER <-- 158/2001	
	72379838	1	CIRCUIT BOARD --> 158/2000 NOT ILLUSTRATED	
	72379855	1	CIRCUIT BOARD <-- 158/2001 NOT ILLUSTRATED	
	72423241	1	TANK TEMPERATURE INDICATOR NOT ILLUSTRATED --> 158/2000	
14	72379840	1	HOUSING NOT ILLUSTRATED	KPL
	72379852	1	RUBBER PROFILE RING NOT ILLUSTRATED	
15	72379833	1	FILAMENT BULB	12V 3W
16			NOT AVAILABLE IN SINGLE PARTS	
17	72379261	15	FILAMENT BULB ><16	12V2W
18	72379832	1	LAMP SOCKET	

FARMER 304 (158/00001-03500)
5418

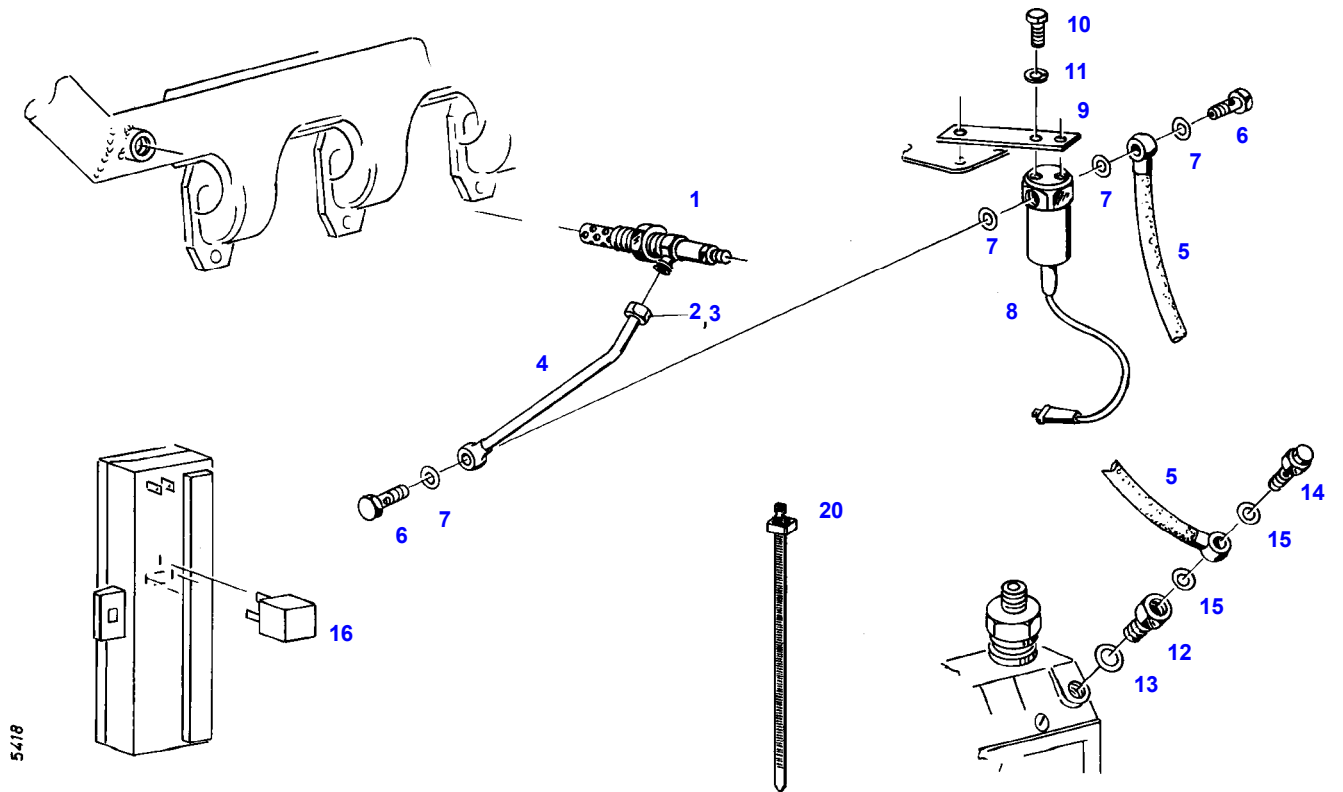

5418

Item	Part Number	Qty	Description Comments	Technical Specification
1	72433489	1	ROD FLAME GLOW PLUG	
2	72378005	1	CONNECTING NUT	DIN 3870 ALL6-9S20K A3L
3	72377312	1	DOUBLE V-RING	DIN 3862-6-9SMNPB28K+G
4	72355751	1	TUBING	
5	72355750	1	LINE	
6	72315806	2	BANJO BOLT	DIN 7643-6-3-A3L
7	72315088	4	SEALING WASHER	DIN 7603 A10X13,5-CU
8	72317090	1	VALVE SOLENOID	
9	72316724	1	RETAINER	
10	72315629	2	HEXAGONAL HEAD BOLT	DIN 933 M6 X 12-8.8A3L
11	72315052	2	SPLIT WASHER	FWN 65208-6-A3L
12	72393707	1	REDUCER	
13	72315097	1	SEALING WASHER	DIN 7603 A16X20-CU
14	72380268	1	BLEED AND DRAIN VALVE	
15	72315094	2	SEALING WASHER	DIN 7603 A14X18-CU
16	72428226	1	GLOW TIME RELAY <>	
	72433489	1	ROD FLAME GLOW PLUG	
17	72450804	1	INSULATING TUBING CUT TO LENGTH NOT ILLUSTRATED	L=2800DIN 40621 B8X0,7-S
	72333918	1	CABLE LUG NOT ILLUSTRATED	
	72314785	2	PLUG IN SLEEVE NOT ILLUSTRATED	
	72314686	1	PLUG IN SLEEVE NOT ILLUSTRATED	
	72316070	1	BUSHING INSULATOR NOT ILLUSTRATED	
20	72316916	3	CABLE STRAP	FWN 66650 B175X4-SW

Thank you so much for reading.
Please click the “Buy Now!”
button below to download the
complete manual.



After you pay.

You can download the most
perfect and complete manual in
the world immediately.

Our support email:

ebooklibonline@outlook.com