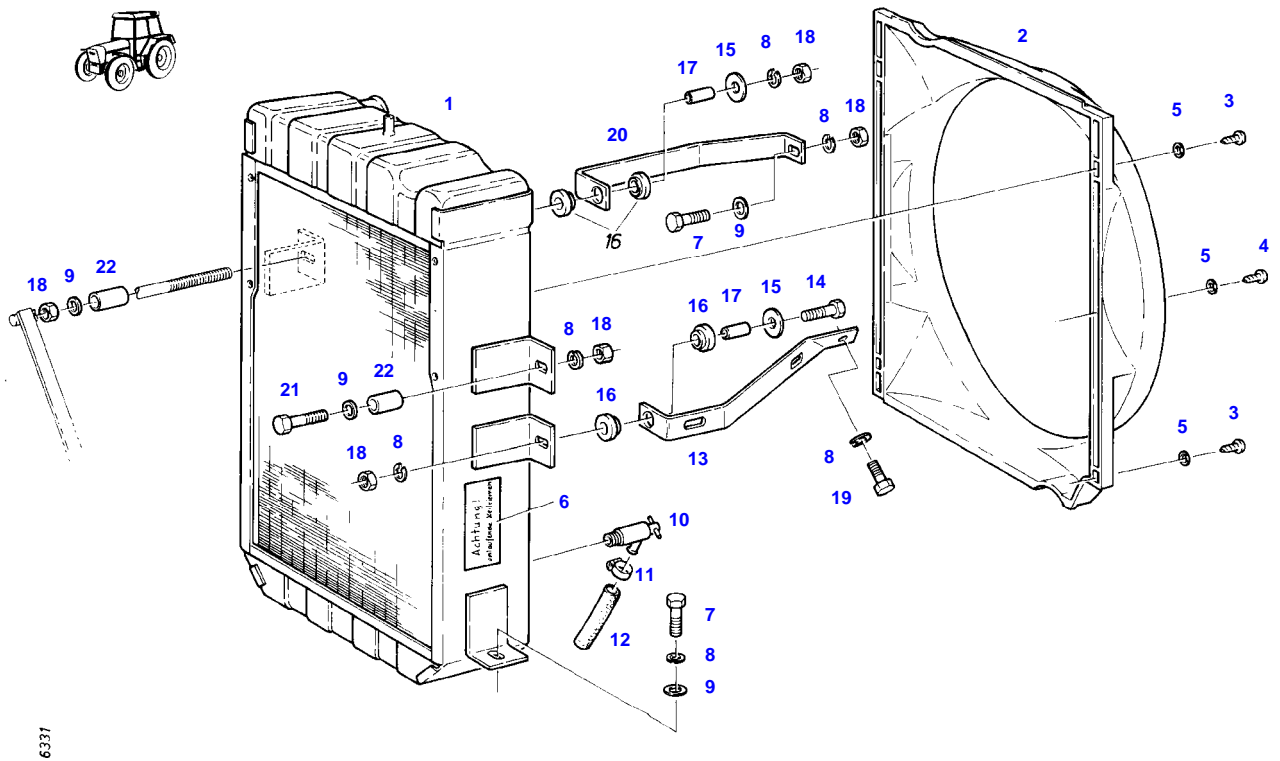

TABLE OF CONTENT

Page Number	Page Title	Page Reference
01-000-TOC	ENGINE, FUEL AND EXHAUST SYSTEM	01-000-TOC
02-000-TOC	AXLES	02-000-TOC
03-000-TOC	STEERING SYSTEM	03-000-TOC
04-000-TOC	DRIVE TRAIN SYSTEM	04-000-TOC
05-000-TOC	COMPRESSED AIR SYSTEM	05-000-TOC
06-000-TOC	HYDRAULIC SYSTEM	06-000-TOC
07-000-TOC	ELECTRICAL SYSTEM	07-000-TOC
08-000-TOC	CAB	08-000-TOC
09-000-TOC	AIR CONDITIONING AND HEATING SYSTEM	09-000-TOC
10-000-TOC	CHASSIS	10-000-TOC
11-000-TOC	WHEELS	11-000-TOC
12-000-TOC	IMPLEMENT LIFT SYSTEM FRONT	12-000-TOC
13-000-TOC	IMPLEMENT LIFT SYSTEM REAR	13-000-TOC
14-000-TOC	FRONT/REAR LOADERS	14-000-TOC
15-000-TOC	ATTACHMENTS	15-000-TOC
16-000-TOC	ACCESSORIES	16-000-TOC

FARMER 308 (178/12001-14100)
6331



Item	Part Number	Qty	Description Comments	Technical Specification
			<-- 178/13000	
1	72348232	1	RADIATOR <-- G186.205.050.010 1X <>	
	72395450	1	BRACKET	
	72315663	1	HEXAGONAL HEAD BOLT	DIN 933 M8X40-8.8A3L
	72400314	1	BUSH	
	72348553	1	RADIATOR RANGE OF TEMPERATURE 2 WITH AIR CONDITION	
2	72393668	1	FAN COVER	
3	72315818	4	SCREW	DIN7976-ST4,2X25-C-A3L
4	72315787	2	SCREW	DIN 7981 B4,2X16-A3L
5	72311817	6	DISC	DIN9021-4,3-140HV-A3L
6	72386100	2	WARNING SIGN D	
	72388085	2	WARNING SIGN GB	
	72388086	2	WARNING SIGN F	
	72388087	2	WARNING SIGN I	
	72388088	2	WARNING SIGN E	
7	72315650	3	HEXAGONAL HEAD BOLT	DIN 933 M8 X 20-8.8A3L
8	72315053	7	SPLIT WASHER	FWN 65208-8-A3L
9	72311788	5	DISC	DIN 125-8,4-ST.A3L
10	72378063	1	RELIEF VALVE	DIN71401-CM14X1,5KEG
11	72438345	1	HOSE CLIP	
12	72389310	1	HOSE	
13	72395409	1	BRACE	
14	72315660	1	HEXAGONAL HEAD BOLT	DIN 933 M8X35-8.8A3L
15	72311888	2	DISC	
16	72312479	4	UNIVERSAL SPOUT	
17	72310718	2	BUSH	
18	72313268	5	NUT	DIN 934 M8-8A3L
19	72315653	1	HEXAGONAL HEAD BOLT	DIN 933 M8 X 25-8.8A3L
20	72393671	1	BRACE	
21	72315650	1	HEXAGONAL HEAD BOLT RANGE OF TEMPERATURE 1+1 WITH AIR RANGE OF TEMPERATURE 2+2 WITH AIR RANGE OF TEMPERATURE 1 WITH AIR BRAKE SUPPLY EQUIPEMENT KLIMAAANLAGE	DIN 933 M8 X 20-8.8A3L
	72315663	1	HEXAGONAL HEAD BOLT RANGE OF TEMPERATURE 2 WITH AIR CONDITION	DIN 933 M8X40-8.8A3L
22	72400314	2	BUSH RANGE OF TEMPERATURE 2 WITH AIR CONDITION	

FARMER 308 (178/12001-14100)
4903

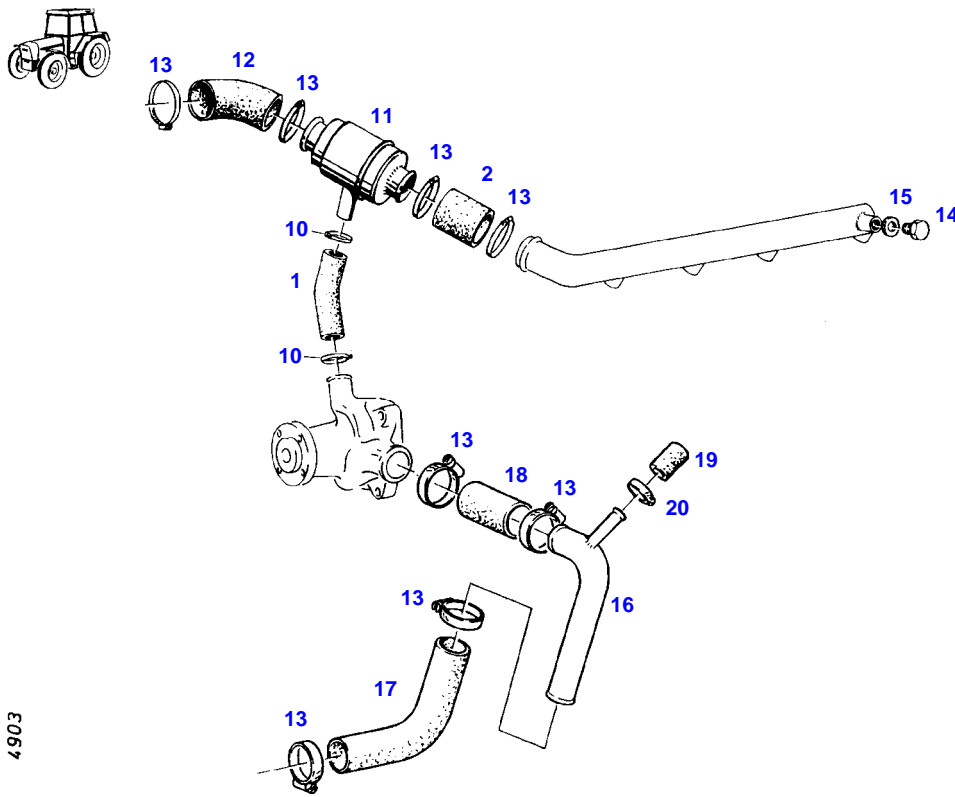

4903

Item	Part Number	Qty	Description Comments	Technical Specification
			RANGE OF TEMPERATURE 1+1 WITH AIR BRAKE SUPPLY EQUIPEMENT	
1	72393670	1	RUBBER ARCH	
2	72450416	1	HOSE 1X 45MM CUT TO LENGTH	L=120 DIN73411-35X
10	72311167	2	HOSE CLIP	
11	72380193	1	THERMOSTAT	75GR+-2GR
12	72393666	1	RUBBER ARCH	
13	72311162	8	HOSE CLIP	
14	72315802	1	SCREW	DIN 7604 AM22X1,5-ST
15	72315101	1	SEALING WASHER	DIN 7603 A22X27-CU
16	72356702	1	SUCTION LINE	
17	72395412	1	RUBBER ARCH	
18	72393672	1	REDUCER	
19	72404925	1	CAP	
20	72311166	1	HOSE CLIP	

FARMER 308 (178/12001-14100)
4903

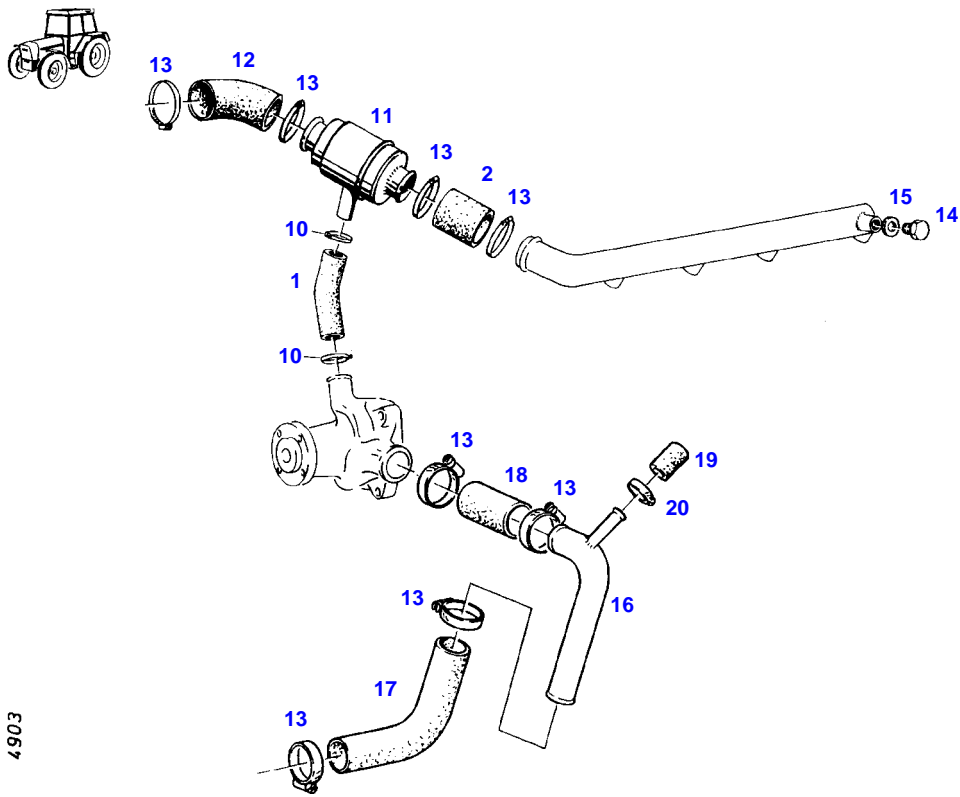

4903

Item	Part Number	Qty	Description Comments	Technical Specification
			RANGE OF TEMPERATURE 2+2 WITH AIR BRAKE SUPPLY EQUIPEMENT	
1	72436027	1	HOSE 1X 120MM	L=320 DIN73411-25X3,5 R
2	72392140	1	RUBBER ARCH	
10	72311167	2	HOSE CLIP	
11	72380193	1	THERMOSTAT	75GR+-2GR
12	72393666	1	RUBBER ARCH	
13	72311162	8	HOSE CLIP	
14	72315802	1	SCREW	DIN 7604 AM22X1,5-ST
15	72315101	1	SEALING WASHER	DIN 7603 A22X27-CU
16	72356702	1	SUCTION LINE	
17	72395412	1	RUBBER ARCH	
18	72393672	1	REDUCER	
19	72404925	1	CAP	
20	72311166	1	HOSE CLIP	

FARMER 308 (178/12001-14100)
6336

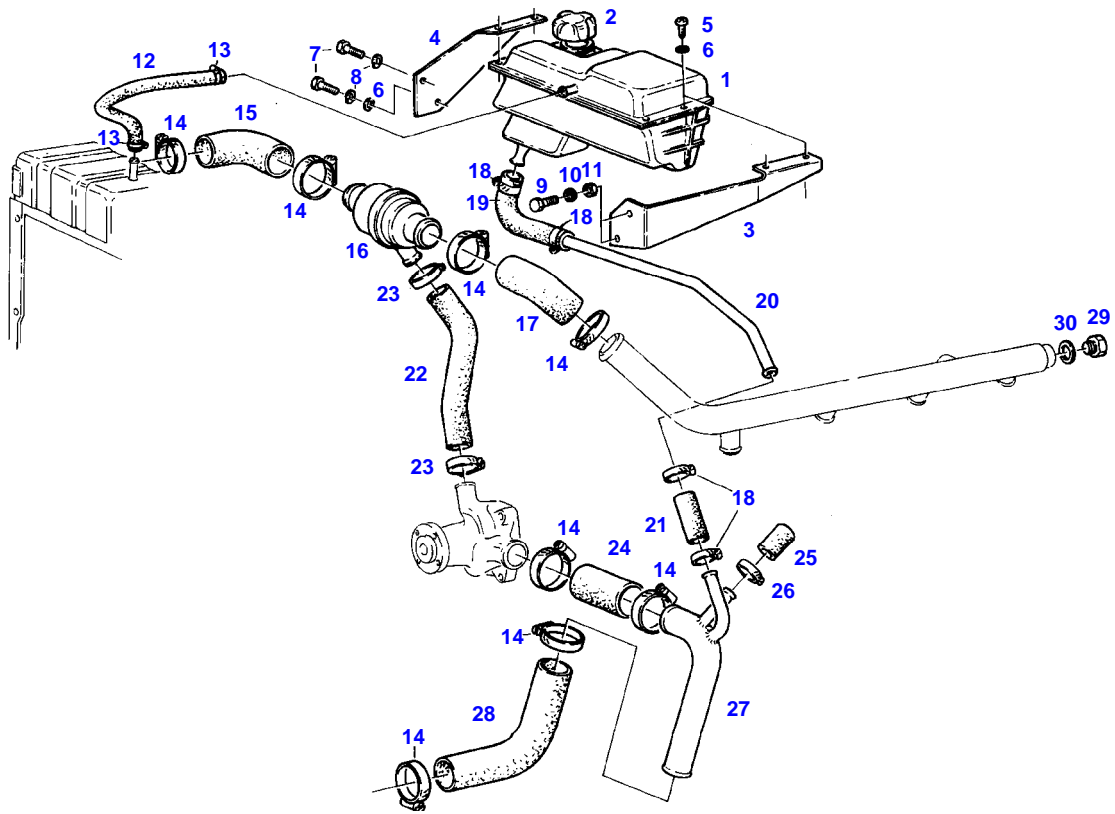

6336

Item	Part Number	Qty	Description Comments	Technical Specification
			<-- 178/13000	
1	72316897	1	EXPANSION TANK	
			<>	
	72438345	1	HOSE CLIP	
	72409370	1	CAP	
2	72348672	1	COLLER LOCKING	
3	72392987	1	BRACKET	
			RANGE OF TEMPERATURE 1+1 WITH AIR	
			RANGE OF TEMPERATURE 2+2 WITH AIR	
			RANGE OF TEMPERATURE 1 WITH AIR	
			BRAKE SUPPLY EQUIPEMENT	
			KLIMAAANLAGE	
	72395450	1	BRACKET	
			RANGE OF TEMPERATURE 2 WITH AIR	
			CONDITION	
4	72392988	1	BRACKET	
5	72315821	4	SCREW	DIN7976-ST6,3X19-C-A3L
6	72311822	5	DISC	DIN9021-6,4-140HV-A3L
7	72315629	2	HEXAGONAL HEAD BOLT	DIN 933 M6 X 12-8.8A3L
8	72315052	2	SPLIT WASHER	FWN 65208-6-A3L
9	72315642	2	HEXAGONAL HEAD BOLT	DIN 933 M8 X 16-8.8A3L
10	72315053	2	SPLIT WASHER	FWN 65208-8-A3L
11	72313268	2	NUT	DIN 934 M8-8A3L
12	72622024	1	PRESSURE HOSE	L=0,50M 8X3,5-FWN65911
			1X 185MM	
			CUT TO LENGTH	
13	72438345	2	HOSE CLIP	
14	72311162	8	HOSE CLIP	
15	72393666	1	RUBBER ARCH	
16	72380193	1	THERMOSTAT	75GR+-2GR
17	72392140	1	RUBBER ARCH	
18	72311166	4	HOSE CLIP	
19	72435869	1	RUBBER ARCH	
20	72392830	1	PIPE	
21	72450412	1	HOSE	L=1000 18X3,5 R DIN 73411
			1X 50MM	
			CUT TO LENGTH	
22	72436027	1	HOSE	L=320 DIN73411-25X3,5 R
			1X 120MM	
			CUT TO LENGTH	
23	72311167	2	HOSE CLIP	
24	72393672	1	REDUCER	
25	72404925	1	CAP	
26	72311166	1	HOSE CLIP	
27	72357308	1	SUCTION LINE	
28	72395412	1	RUBBER ARCH	
29	72315802	1	SCREW	DIN 7604 AM22X1,5-ST
30	72315101	1	SEALING WASHER	DIN 7603 A22X27-CU

FARMER 308 (178/12001-14100)
5407

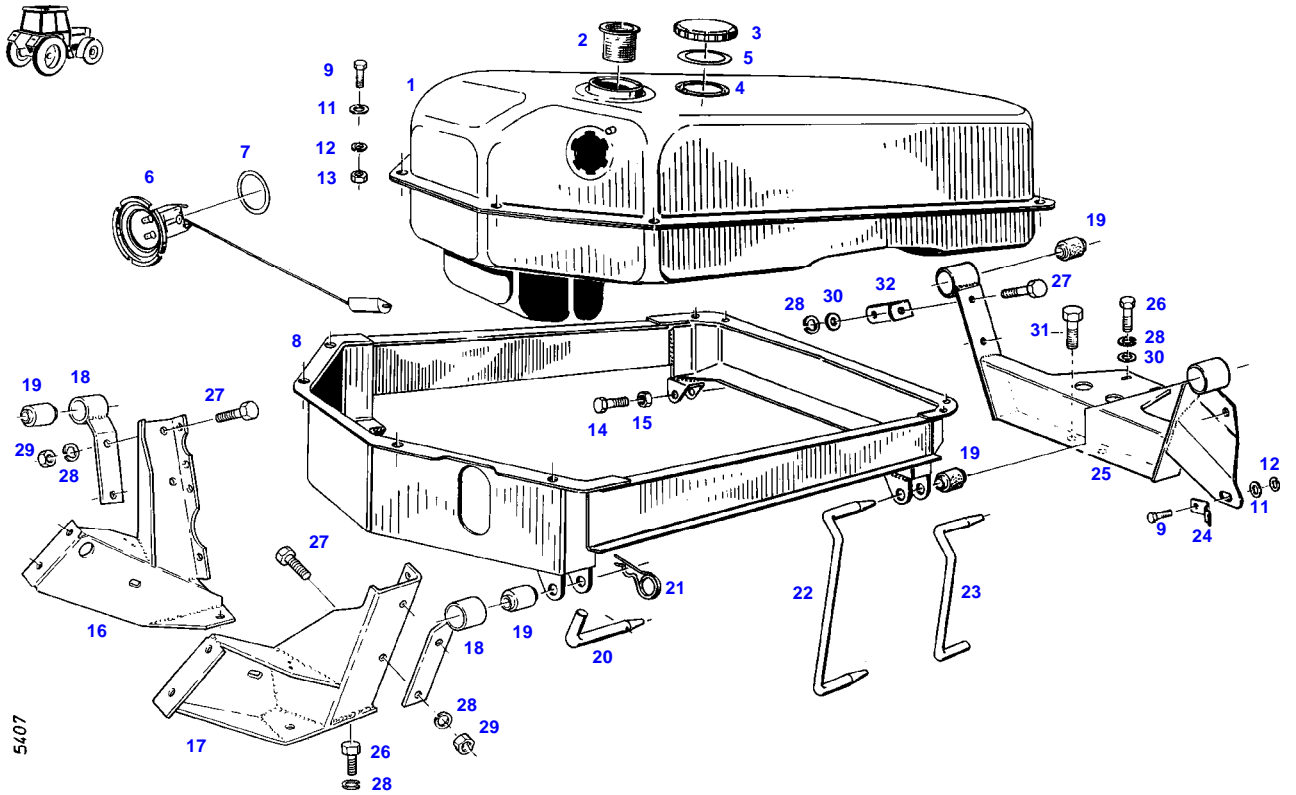

Item	Part Number	Qty	Description Comments	Technical Specification
			--> 178/12619	
1	72349985	1	FUEL TANK <>	
	72348556	1	FUEL LEVEL SENSOR	
	72409022	2	FLANGE	
	72315619	10	HEXAGONAL HEAD BOLT	DIN 933 M5X16-8.8A3L
	72376017	2	SEALING WASHER	DIN 7603-A5X7,5-CU
	72376132	2	SEALING WASHER	
	72376018	8	SEALING WASHER	DIN 7603 A5X9-VF
2	72433112	1	STRAINER	60X100-MS
3	72380143	1	FUEL CAP KOEHLER	M.BELUEF
			><3+4	
	72348297	1	FUEL CAP LOCKABLE BLAU	
			><3-5	
4	72330725	1	SEAL BLAU	
	72312304	1	RUBBER SEAL KOEHLER	
5	72330726	1	SEAL BLAU	
6	72613041	1	FUEL LEVEL SENSOR	
7	72315169	1	SEALING WASHER	
8	72357106	1	TANK FRAME	
9	72315626	7	HEXAGONAL HEAD BOLT	DIN 933-M6 X 16-8.8-A3L
11	72311822	12	DISC	DIN9021-6,4-140HV-A3L
12	72315052	8	SPLIT WASHER	FWN 65208-6-A3L
13	72313266	8	NUT	DIN 934 M6-8A3L
14	72315719	2	HEXAGONAL HEAD BOLT	DIN 933 M12X60-8.8A3L
15	72313325	2	NUT	DIN 980-VM12-8-A3L
16	72355440	1	BRACKET	
17	72355441	1	BRACKET	
18	72356758	2	SUPPORT ARM	
19	72310644	4	RUBBER BUSHING	
20	72404932	1	BEARING PIN	
21	72311183	1	HAIR COTTER PIN	DIN 11024-4-A3L
22	72393676	1	BEARING PIN	
23	72393681	1	BEARING PIN	
24	72393680	1	LEAF SPRING	
25	72355727	1	CROSSMEMBER	
26	72315642	8	HEXAGONAL HEAD BOLT	DIN 933 M8 X 16-8.8A3L
27	72315653	5	HEXAGONAL HEAD BOLT	DIN 933 M8 X 25-8.8A3L
28	72315053	13	SPLIT WASHER	FWN 65208-8-A3L
29	72313268	4	NUT	DIN 934 M8-8A3L
30	72311788	2	DISC	DIN 125-8,4-ST.A3L
31	72315675	2	HEXAGONAL HEAD BOLT	DIN 933 M10X16-8.8A3L
32	72393683	1	ANGLE	

FARMER 308 (178/12001-14100)
6028

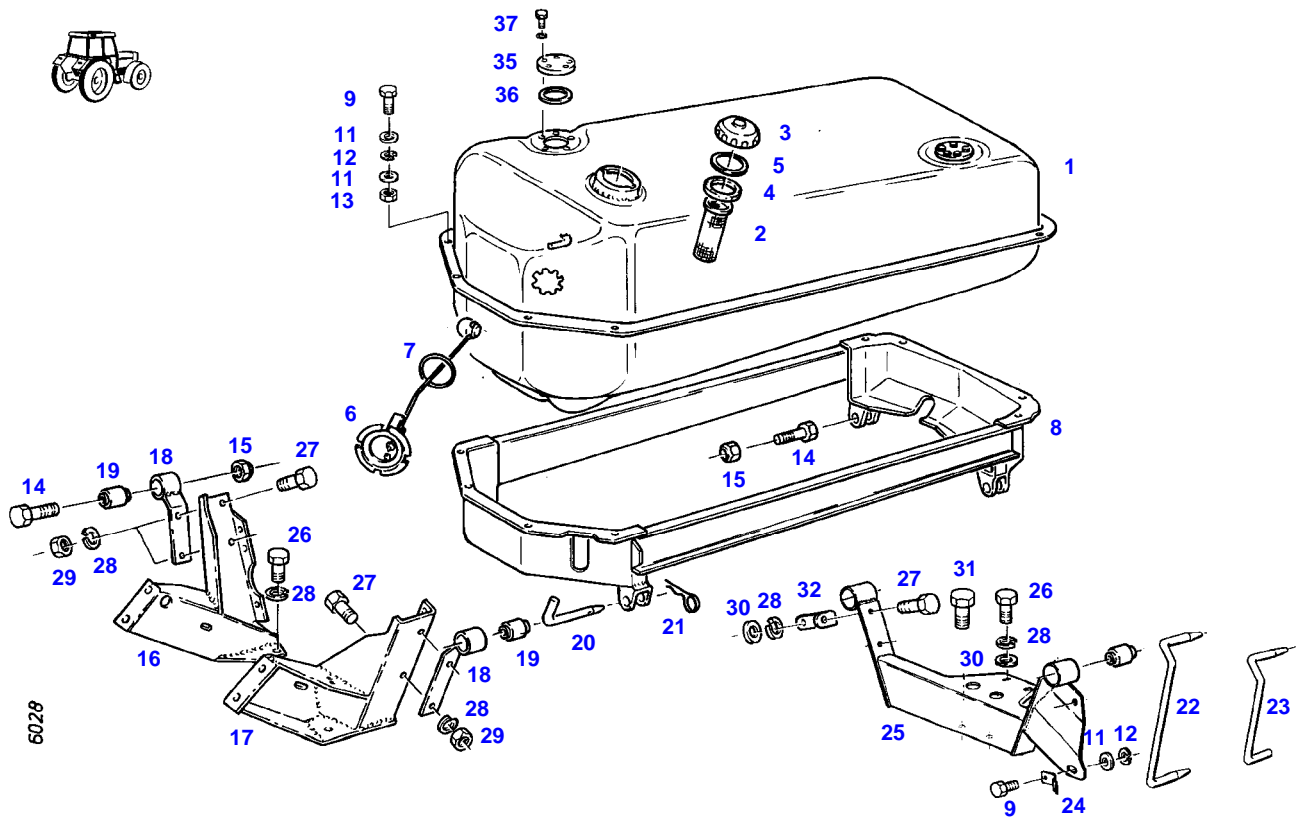

6028

Item	Part Number	Qty	Description Comments	Technical Specification
			<-- 178/12620 --> 178/12999	
1	72349985	1	FUEL TANK	
			<>	
	72376132	2	SEALING WASHER	
	72376018	8	SEALING WASHER	DIN 7603 A5X9-VF
	72376017	2	SEALING WASHER	DIN 7603-A5X7,5-CU
	72315619	10	HEXAGONAL HEAD BOLT	DIN 933 M5X16-8.8A3L
	72409022	2	FLANGE	
	72348556	1	FUEL LEVEL SENSOR	
2	72433112	1	STRAINER	60X100-MS
3	72380143	1	FUEL CAP KOEHLER	M.BELUEF
			><3+4	
	72348297	1	FUEL CAP LOCKABLE BLAU	
			><3-5	
4	72330725	1	SEAL BLAU	
	72312304	1	RUBBER SEAL KOEHLER	
5	72330726	1	SEAL BLAU	
6	72613041	1	FUEL LEVEL SENSOR	
7	72315169	1	SEALING WASHER	
8	72357106	1	TANK FRAME	
9	72315626	7	HEXAGONAL HEAD BOLT	DIN 933-M6 X 16-8.8-A3L
11	72311822	12	DISC	DIN9021-6,4-140HV-A3L
12	72315052	8	SPLIT WASHER	FWN 65208-6-A3L
13	72313266	8	NUT	DIN 934 M6-8A3L
14	72315719	2	HEXAGONAL HEAD BOLT	DIN 933 M12X60-8.8A3L
15	72313325	2	NUT	DIN 980-VM12-8-A3L
16	72356748	1	BRACKET	
17	72356749	1	BRACKET	
18	72356758	2	SUPPORT ARM	
19	72310644	4	RUBBER BUSHING	
20	72404932	1	BEARING PIN	
21	72311183	1	HAIR COTTER PIN	DIN 11024-4-A3L
22	72393676	1	BEARING PIN	
23	72393681	1	BEARING PIN	
24	72393680	1	LEAF SPRING	
25	72355727	1	CROSSMEMBER	
26	72315642	8	HEXAGONAL HEAD BOLT	DIN 933 M8 X 16-8.8A3L
27	72315653	5	HEXAGONAL HEAD BOLT	DIN 933 M8 X 25-8.8A3L
28	72315053	13	SPLIT WASHER	FWN 65208-8-A3L
29	72313268	4	NUT	DIN 934 M8-8A3L
30	72311788	2	DISC	DIN 125-8,4-ST.A3L
31	72315675	2	HEXAGONAL HEAD BOLT	DIN 933 M10X16-8.8A3L
32	72393683	1	ANGLE	
35	72409022	2	FLANGE	
36	72376132	2	SEALING WASHER	
			<>38	
			<>	
	72376018	10	SEALING WASHER	DIN 7603 A5X9-VF
37	72315619	10	HEXAGONAL HEAD BOLT	DIN 933 M5X16-8.8A3L
38	72376018	10	SEALING WASHER	DIN 7603 A5X9-VF

FARMER 308 (178/12001-14100)
6029

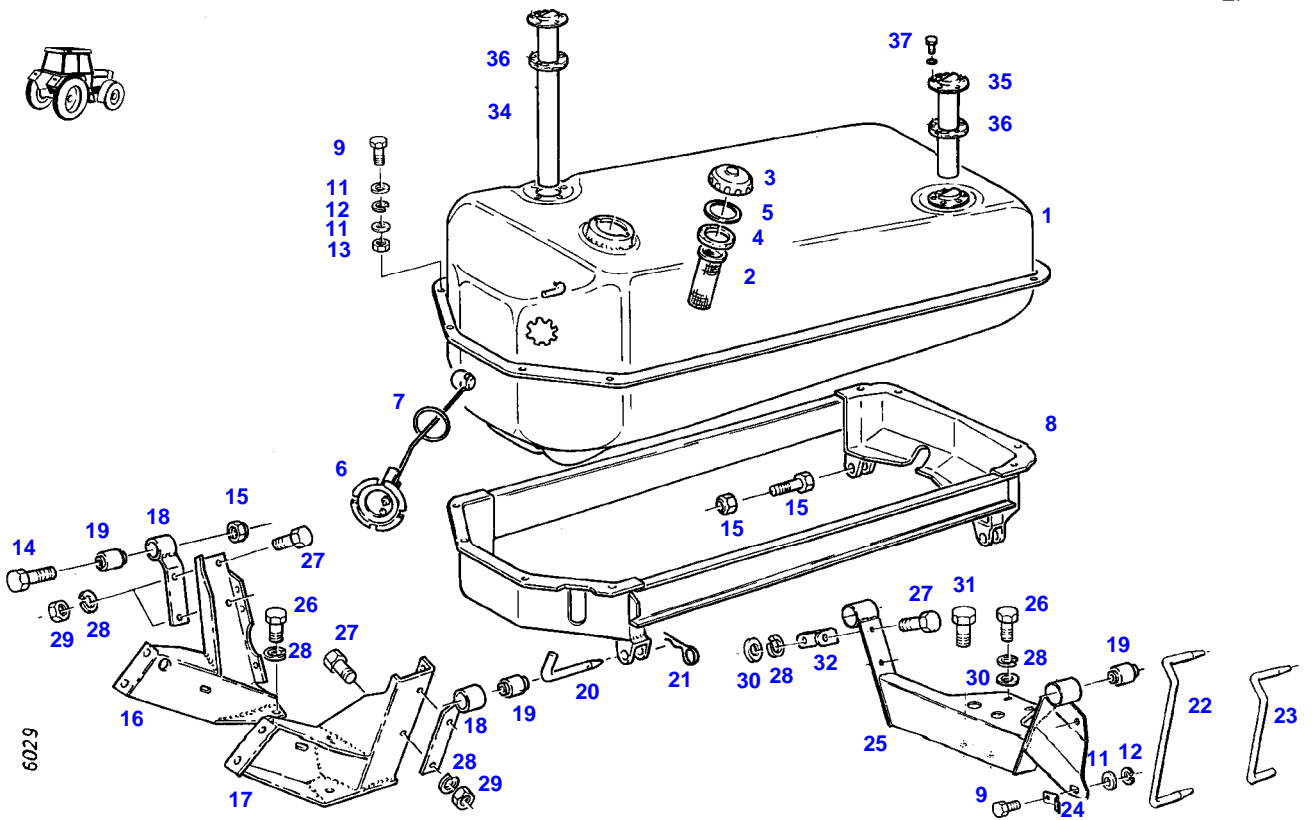

Item	Part Number	Qty	Description Comments	Technical Specification
BOARD COMPUTER				
1	72349985	1	FUEL TANK <>	
	72409022	2	FLANGE	
	72315619	10	HEXAGONAL HEAD BOLT	DIN 933 M5X16-8.8A3L
	72348556	1	FUEL LEVEL SENSOR	
	72376132	2	SEALING WASHER	
	72376017	2	SEALING WASHER	DIN 7603-A5X7,5-CU
	72376018	8	SEALING WASHER	DIN 7603 A5X9-VF
2	72433112	1	STRAINER	60X100-MS
3	72380143	1	FUEL CAP KOEHLER	M.BELUEF
	72348297	1	><3+4 FUEL CAP LOCKABLE BLAU ><3-5	
4	72330725	1	SEAL BLAU	
	72312304	1	RUBBER SEAL KOEHLER	
5	72330726	1	SEAL BLAU	
6	72613041	1	FUEL LEVEL SENSOR	
7	72315169	1	SEALING WASHER	
8	72357106	1	TANK FRAME	
9	72315626	7	HEXAGONAL HEAD BOLT	DIN 933-M6 X 16-8.8-A3L
11	72311822	12	DISC	DIN9021-6,4-140HV-A3L
12	72315052	8	SPLIT WASHER	FWN 65208-6-A3L
13	72313266	8	NUT	DIN 934 M6-8A3L
14	72315719	2	HEXAGONAL HEAD BOLT	DIN 933 M12X60-8.8A3L
15	72313325	2	NUT	DIN 980-VM12-8-A3L
16	72356748	1	BRACKET	
17	72356749	1	BRACKET	
18	72356758	2	SUPPORT ARM	
19	72310644	4	RUBBER BUSHING	
20	72404932	1	BEARING PIN	
21	72311183	1	HAIR COTTER PIN	DIN 11024-4-A3L
22	72393676	1	BEARING PIN	
23	72393681	1	BEARING PIN	
24	72393680	1	LEAF SPRING	
25	72355727	1	CROSSMEMBER	
26	72315642	8	HEXAGONAL HEAD BOLT	DIN 933 M8 X 16-8.8A3L
27	72315653	5	HEXAGONAL HEAD BOLT	DIN 933 M8 X 25-8.8A3L
28	72315053	13	SPLIT WASHER	FWN 65208-8-A3L
29	72313268	4	NUT	DIN 934 M8-8A3L
30	72311788	2	DISC	DIN 125-8,4-ST.A3L
31	72315675	2	HEXAGONAL HEAD BOLT	DIN 933 M10X16-8.8A3L
32	72393683	1	ANGLE	
34	72380156	1	FUEL LEVEL SENSOR	
35	72380157	1	FUEL LEVEL SENSOR	
36	72376132	2	SEALING WASHER <>38,39 <>	
	72376017	2	SEALING WASHER	DIN 7603-A5X7,5-CU
	72376018	8	SEALING WASHER	DIN 7603 A5X9-VF
37	72315619	10	HEXAGONAL HEAD BOLT	DIN 933 M5X16-8.8A3L
38	72376018	8	SEALING WASHER	DIN 7603 A5X9-VF
39	72376017	2	SEALING WASHER	DIN 7603-A5X7,5-CU

FARMER 308 (178/12001-14100)
6024

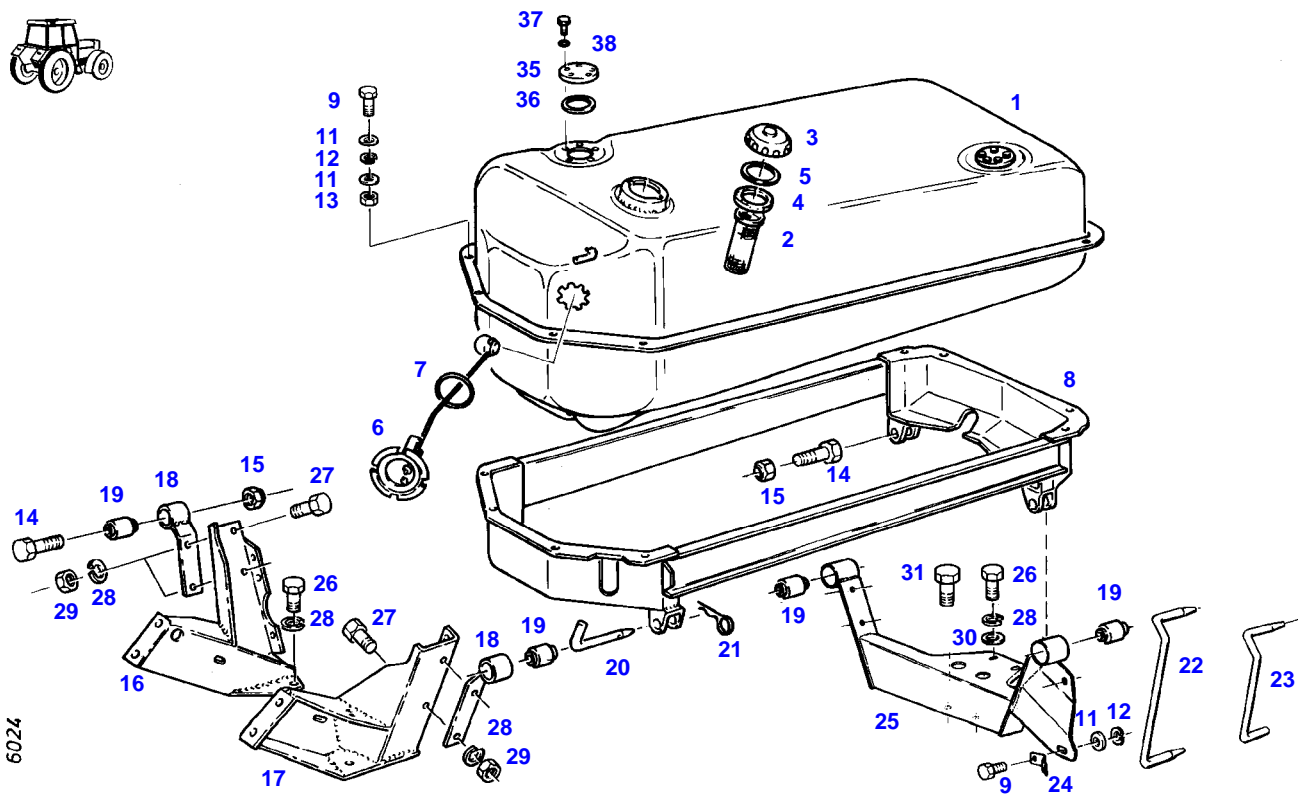

6024

Item	Part Number	Qty	Description Comments	Technical Specification
			<-- 178/13000	
1	72349985	1	FUEL TANK	
			<>	
	72409022	2	FLANGE	
	72376017	2	SEALING WASHER	DIN 7603-A5X7,5-CU
	72376132	2	SEALING WASHER	
	72315619	10	HEXAGONAL HEAD BOLT	DIN 933 M5X16-8.8A3L
	72348556	1	FUEL LEVEL SENSOR	
	72376018	8	SEALING WASHER	DIN 7603 A5X9-VF
2	72433112	1	STRAINER	60X100-MS
3	72380143	1	FUEL CAP KOEHLER	M.BELUEF
			><3+4	
	72348297	1	FUEL CAP LOCKABLE BLAU	
			><3-5	
4	72330725	1	SEAL BLAU	
	72312304	1	RUBBER SEAL KOEHLER	
5	72330726	1	SEAL BLAU	
6	72613041	1	FUEL LEVEL SENSOR	
7	72315169	1	SEALING WASHER	
8	72357106	1	TANK FRAME	
9	72315626	7	HEXAGONAL HEAD BOLT	DIN 933-M6 X 16-8.8-A3L
11	72311822	12	DISC	DIN9021-6,4-140HV-A3L
12	72315052	8	SPLIT WASHER	FWN 65208-6-A3L
13	72313266	8	NUT	DIN 934 M6-8A3L
14	72315719	2	HEXAGONAL HEAD BOLT	DIN 933 M12X60-8.8A3L
15	72313325	2	NUT	DIN 980-VM12-8-A3L
16	72356748	1	BRACKET	
17	72356749	1	BRACKET	
18	72356758	2	SUPPORT ARM	
19	72310644	4	RUBBER BUSHING	
20	72404932	1	BEARING PIN	
21	72311183	1	HAIR COTTER PIN	DIN 11024-4-A3L
22	72393676	1	BEARING PIN	
23	72393681	1	BEARING PIN	
24	72393680	1	LEAF SPRING	
25	72355727	1	CROSSMEMBER	
26	72315642	8	HEXAGONAL HEAD BOLT	DIN 933 M8 X 16-8.8A3L
27	72315657	4	HEXAGONAL HEAD BOLT	DIN 933 M8 X 30-8.8A3L
28	72315053	12	SPLIT WASHER	FWN 65208-8-A3L
29	72313268	4	NUT	DIN 934 M8-8A3L
30	72311788	2	DISC	DIN 125-8,4-ST.A3L
31	72315675	2	HEXAGONAL HEAD BOLT	DIN 933 M10X16-8.8A3L
35	72409022	2	FLANGE	
36	72376132	2	SEALING WASHER	
			<>38	
			<>	
	72376018	10	SEALING WASHER	DIN 7603 A5X9-VF
37	72315619	10	HEXAGONAL HEAD BOLT	DIN 933 M5X16-8.8A3L
38	72376018	10	SEALING WASHER	DIN 7603 A5X9-VF

FARMER 308 (178/12001-14100)
6357

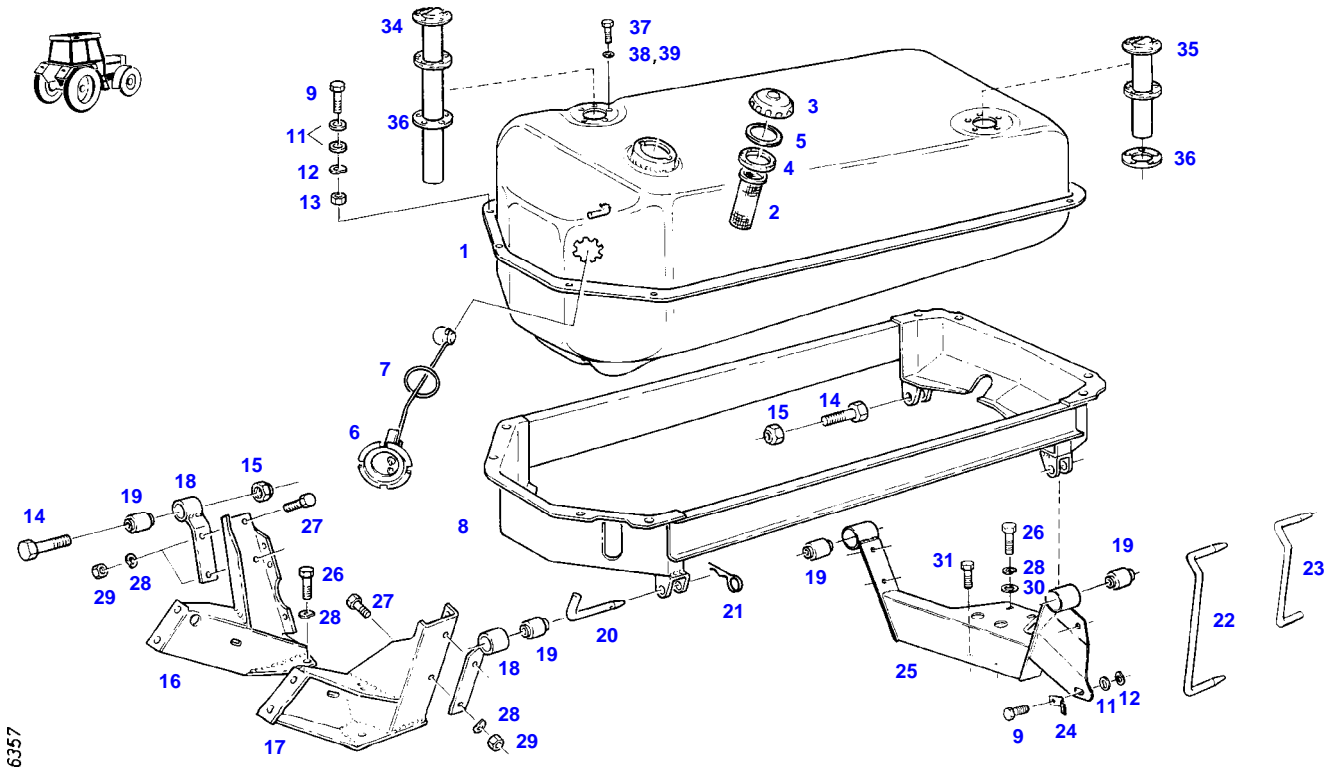

Item	Part Number	Qty	Description Comments	Technical Specification
BOARD COMPUTER				
1	72349985	1	FUEL TANK <>	
	72376017	2	SEALING WASHER	DIN 7603-A5X7,5-CU
	72409022	2	FLANGE	
	72376132	2	SEALING WASHER	
	72348556	1	FUEL LEVEL SENSOR	
	72376018	8	SEALING WASHER	DIN 7603 A5X9-VF
	72315619	10	HEXAGONAL HEAD BOLT	DIN 933 M5X16-8.8A3L
2	72433112	1	STRAINER	60X100-MS
3	72380143	1	FUEL CAP KOEHLER	M.BELUEF
			><3+4	
	72348297	1	FUEL CAP LOCKABLE BLAU	
			><3-5	
4	72330725	1	SEAL BLAU	
	72312304	1	RUBBER SEAL KOEHLER	
5	72330726	1	SEAL BLAU	
6	72613041	1	FUEL LEVEL SENSOR	
7	72315169	1	SEALING WASHER	
8	72357106	1	TANK FRAME	
9	72315626	7	HEXAGONAL HEAD BOLT	DIN 933-M6 X 16-8.8-A3L
11	72311822	12	DISC	DIN9021-6,4-140HV-A3L
12	72315052	8	SPLIT WASHER	FWN 65208-6-A3L
13	72313266	8	NUT	DIN 934 M6-8A3L
14	72315719	2	HEXAGONAL HEAD BOLT	DIN 933 M12X60-8.8A3L
15	72313325	2	NUT	DIN 980-VM12-8-A3L
16	72356748	1	BRACKET	
17	72356749	1	BRACKET	
18	72356758	2	SUPPORT ARM	
19	72310644	4	RUBBER BUSHING	
20	72404932	1	BEARING PIN	
21	72311183	1	HAIR COTTER PIN	DIN 11024-4-A3L
22	72393676	1	BEARING PIN	
23	72393681	1	BEARING PIN	
24	72393680	1	LEAF SPRING	
25	72355727	1	CROSSMEMBER	
26	72315642	8	HEXAGONAL HEAD BOLT	DIN 933 M8 X 16-8.8A3L
27	72315657	4	HEXAGONAL HEAD BOLT	DIN 933 M8 X 30-8.8A3L
28	72315053	12	SPLIT WASHER	FWN 65208-8-A3L
29	72313268	4	NUT	DIN 934 M8-8A3L
30	72311788	2	DISC	DIN 125-8,4-ST.A3L
31	72315675	2	HEXAGONAL HEAD BOLT	DIN 933 M10X16-8.8A3L
34	72380156	1	FUEL LEVEL SENSOR	
35	72380157	1	FUEL LEVEL SENSOR	
36	72376132	2	SEALING WASHER <>38,39 <>	
	72376018	8	SEALING WASHER	DIN 7603 A5X9-VF
	72376017	2	SEALING WASHER	DIN 7603-A5X7,5-CU
37	72315619	10	HEXAGONAL HEAD BOLT	DIN 933 M5X16-8.8A3L
38	72376018	8	SEALING WASHER	DIN 7603 A5X9-VF
39	72376017	2	SEALING WASHER	DIN 7603-A5X7,5-CU

FARMER 308 (178/12001-14100)
40848

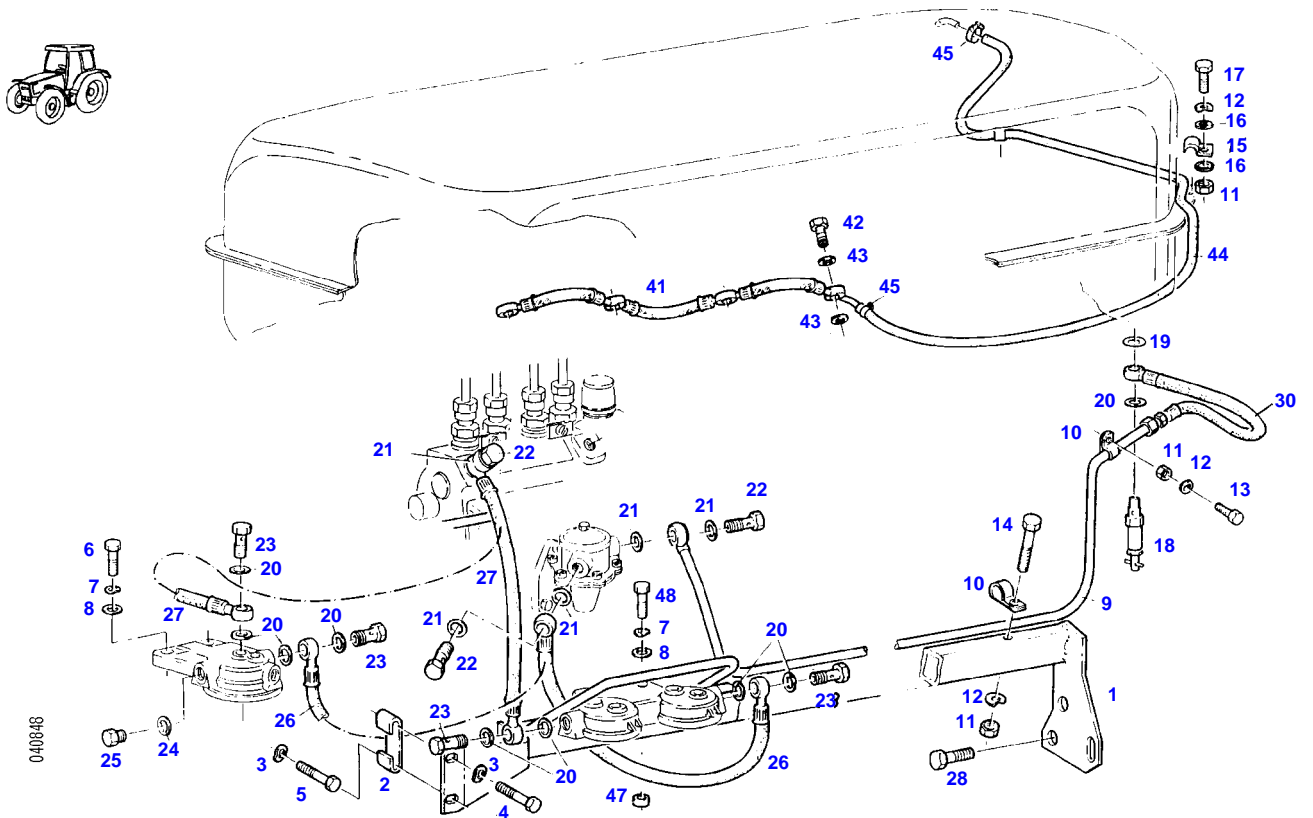

Item	Part Number	Qty	Description Comments	Technical Specification
			--> 178/12999	
1	72356743	1	RETAINER	
2	72399913	1	HOLDER	
3	72317122	2	SPRING WASHER	DIN 137 B10-MECH.VZK
4	72315689	1	HEXAGONAL HEAD BOLT	DIN 933 M10X35-8.8A3L
5	72315691	1	HEXAGONAL HEAD BOLT	DIN 933 M10X40-8.8A3L
6	72315657	2	HEXAGONAL HEAD BOLT	DIN 933 M8 X 30-8.8A3L
7	72315053	2	SPLIT WASHER	FWN 65208-8-A3L
8	72311824	2	DISC	DIN9021-8,4-140HV-A3L
9	72356707	1	TUBING	
10	72311241	2	PIPE CLAMP	
11	72313266	3	NUT	DIN 934 M6-8A3L
12	72315052	3	SPLIT WASHER	FWN 65208-6-A3L
13	72315626	1	HEXAGONAL HEAD BOLT	DIN 933-M6 X 16-8.8-A3L
	72311787	1	DISC	DIN 125-6,4-ST.A3L
			NOT ILLUSTRATED	
14	72315637	1	HEXAGONAL HEAD BOLT	DIN 933 M6X45-8.8A3L
15	72398941	2	FASTENING COLLAR	
16	72311822	4	DISC	DIN9021-6,4-140HV-A3L
17	72315631	2	HEXAGONAL HEAD BOLT	DIN 933 M6 X 20-8.8A3L
18	72380159	1	FUEL SHUT-OFF VALVE	
19	72315093	1	SEALING WASHER	DIN 7603 A12X18-CU
20	72315095	5	SEALING WASHER	DIN 7603 A14X20-CU
21	72315095	6	SEALING WASHER	DIN 7603 A14X20-CU
22	72315808	3	BANJO BOLT	DIN 7643-10-3-A3L
23	72315808	2	BANJO BOLT	DIN 7643-10-3-A3L
24	72315095	2	SEALING WASHER	DIN 7603 A14X20-CU
25	72315799	2	PLUG	DIN 7604 AM14X1,5-A3L
26	72356760	1	FUEL LINE	
27	72355537	1	FUEL LINE	
28	72374490	2	HEXAGONAL HEAD BOLT	DIN 933 M14X20-8.8
	72374493	2	HEXAGONAL HEAD BOLT	DIN 933 M14X30-8.8
30	72357312	1	HOSE LINE	
41	72339360	1	LEAKAGE OIL LINE	
42	72315809	4	BANJO BOLT	DIN 7643-4-5-A3L
43	72315086	8	SEALING WASHER	DIN 7603 A8X11,5-CU
44	72378086	1	PRESSURE HOSE	FWN 66041-P4
45	72438345	2	HOSE CLIP	
47	72311848	2	DISC	
48	72315660	2	HEXAGONAL HEAD BOLT	DIN 933 M8X35-8.8A3L

FARMER 308 (178/12001-14100)
40845

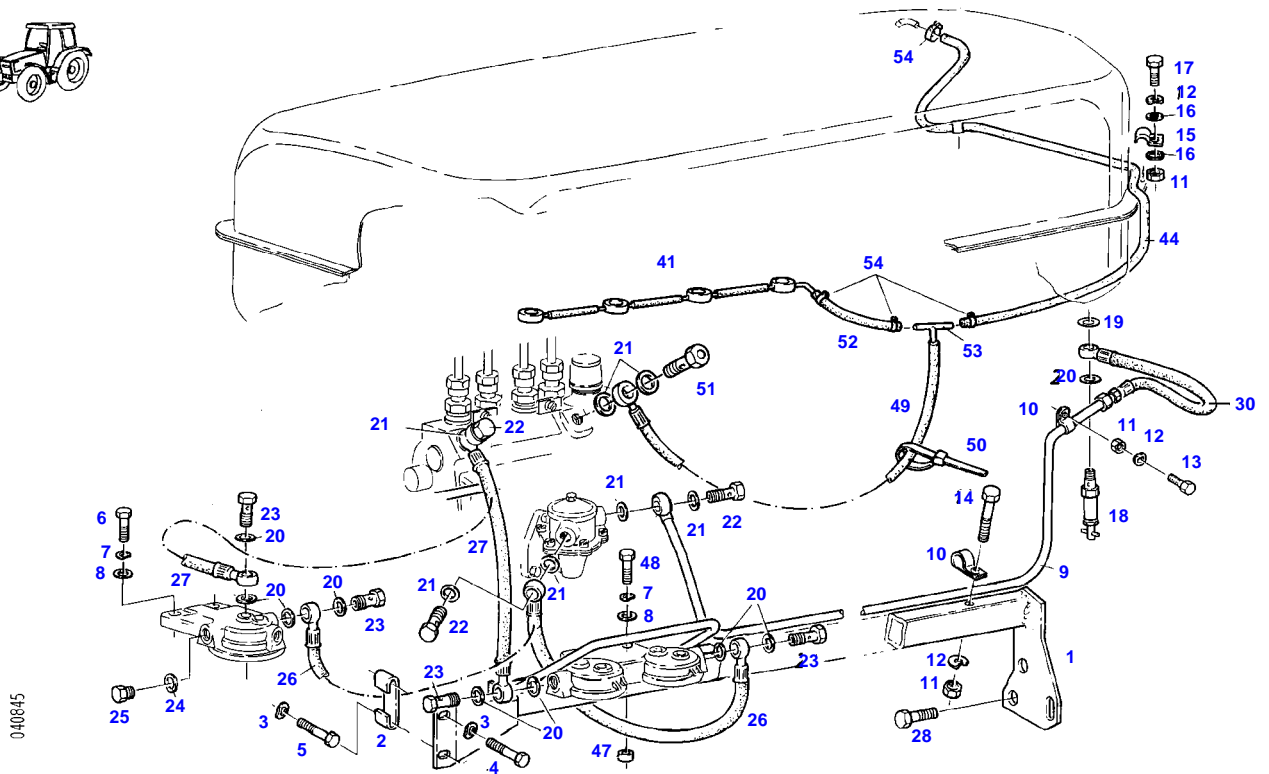

040845

Item	Part Number	Qty	Description Comments	Technical Specification
			<-- 178/13000	
1	72356743	1	RETAINER	
2	72399913	1	HOLDER	
3	72317122	2	SPRING WASHER	DIN 137 B10-MECH.VZK
4	72315689	1	HEXAGONAL HEAD BOLT	DIN 933 M10X35-8.8A3L
5	72315691	1	HEXAGONAL HEAD BOLT	DIN 933 M10X40-8.8A3L
6	72315657	2	HEXAGONAL HEAD BOLT	DIN 933 M8 X 30-8.8A3L
7	72315053	2	SPLIT WASHER	FWN 65208-8-A3L
8	72311824	2	DISC	DIN9021-8,4-140HV-A3L
9	72356707	1	TUBING	
10	72311241	2	PIPE CLAMP	
11	72313266	3	NUT	DIN 934 M6-8A3L
12	72315052	3	SPLIT WASHER	FWN 65208-6-A3L
13	72315626	1	HEXAGONAL HEAD BOLT	DIN 933-M6 X 16-8.8-A3L
	72311787	1	DISC	DIN 125-6,4-ST.A3L
			NOT ILLUSTRATED	
14	72315637	1	HEXAGONAL HEAD BOLT	DIN 933 M6X45-8.8A3L
15	72398941	2	FASTENING COLLAR	
16	72311822	4	DISC	DIN9021-6,4-140HV-A3L
17	72315631	2	HEXAGONAL HEAD BOLT	DIN 933 M6 X 20-8.8A3L
18	72380159	1	FUEL SHUT-OFF VALVE	
19	72315093	1	SEALING WASHER	DIN 7603 A12X18-CU
20	72315095	7	SEALING WASHER	DIN 7603 A14X20-CU
21	72315095	6	SEALING WASHER	DIN 7603 A14X20-CU
22	72315808	2	BANJO BOLT	DIN 7643-10-3-A3L
23	72315808	3	BANJO BOLT	DIN 7643-10-3-A3L
24	72315095	2	SEALING WASHER	DIN 7603 A14X20-CU
25	72315799	2	PLUG	DIN 7604 AM14X1,5-A3L
26	72356760	1	FUEL LINE	
27	72355537	1	FUEL LINE	
28	72374490	2	HEXAGONAL HEAD BOLT	DIN 933 M14X20-8.8
	72374493	2	HEXAGONAL HEAD BOLT	DIN 933 M14X30-8.8
30	72357312	1	HOSE LINE	
41	72332525	1	LEAKAGE OIL LINE	
44	72435830	1	PRESSURE HOSE	L=2100
			1100 MM	
			CUT TO LENGTH	
47	72311848	2	DISC	
48	72315660	2	HEXAGONAL HEAD BOLT	DIN 933 M8X35-8.8A3L
49	72356761	1	FUEL LINE	
50	72316916	2	CABLE STRAP	FWN 66650 B175X4-SW
51	72380268	1	BLEED AND DRAIN VALVE	
52	72450301	1	PRESSURE HOSE	L=1000
			260 MM	
			CUT TO LENGTH	
53	72380023	1	TEE FITTING	
54	72438345	5	HOSE CLIP	

FARMER 308 (178/12001-14100)
4952

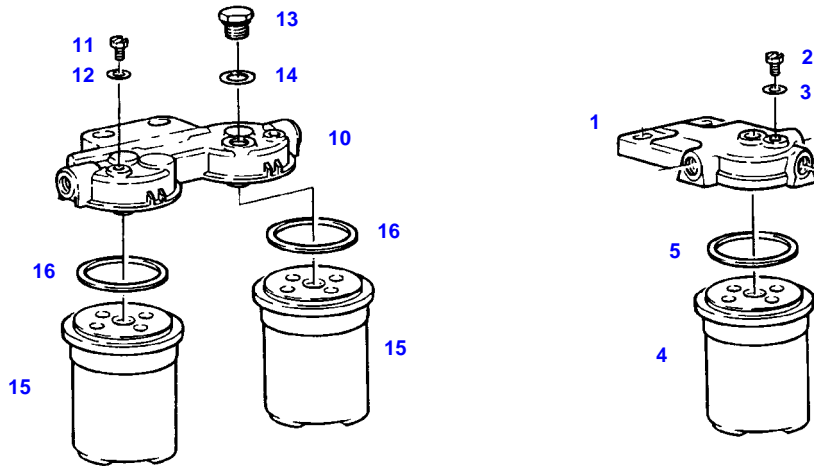

4952

Item	Part Number	Qty	Description Comments	Technical Specification
1	72615599	1	FILTER LID ><2,3	
2	72323290	1	BLEED SCREW	
3	72315084	1	SEALING WASHER	DIN 7603 A6X10-CU
4	72416928	1	FILTER BOX ><5	
5	72314995	1	RUBBER RING PARALLEL-FILTER	
10	72380173	1	PARALLEL FILTER BOSCH ><11-16 <-- X810.190.166.000 1X <>	
	72416928	2	FILTER BOX	
	72451307	1	COVER KNECHT ><11,12 <>	PARALLELFILT.
	72416928	2	FILTER BOX	
11	72323290	2	BLEED SCREW BOSCH	
	72314699	2	BLEED SCREW KNECHT	
12	72315084	2	SEALING WASHER BOSCH	DIN 7603 A6X10-CU
	72315086	2	SEALING WASHER KNECHT	DIN 7603 A8X11,5-CU
13	72326250	1	SCREW BOSCH	
14	72315095	1	SEALING WASHER BOSCH	DIN 7603 A14X20-CU
15	72416928	2	FILTER BOX ><16	
16	72314995	2	RUBBER RING	

FARMER 308 (178/12001-14100)
5425

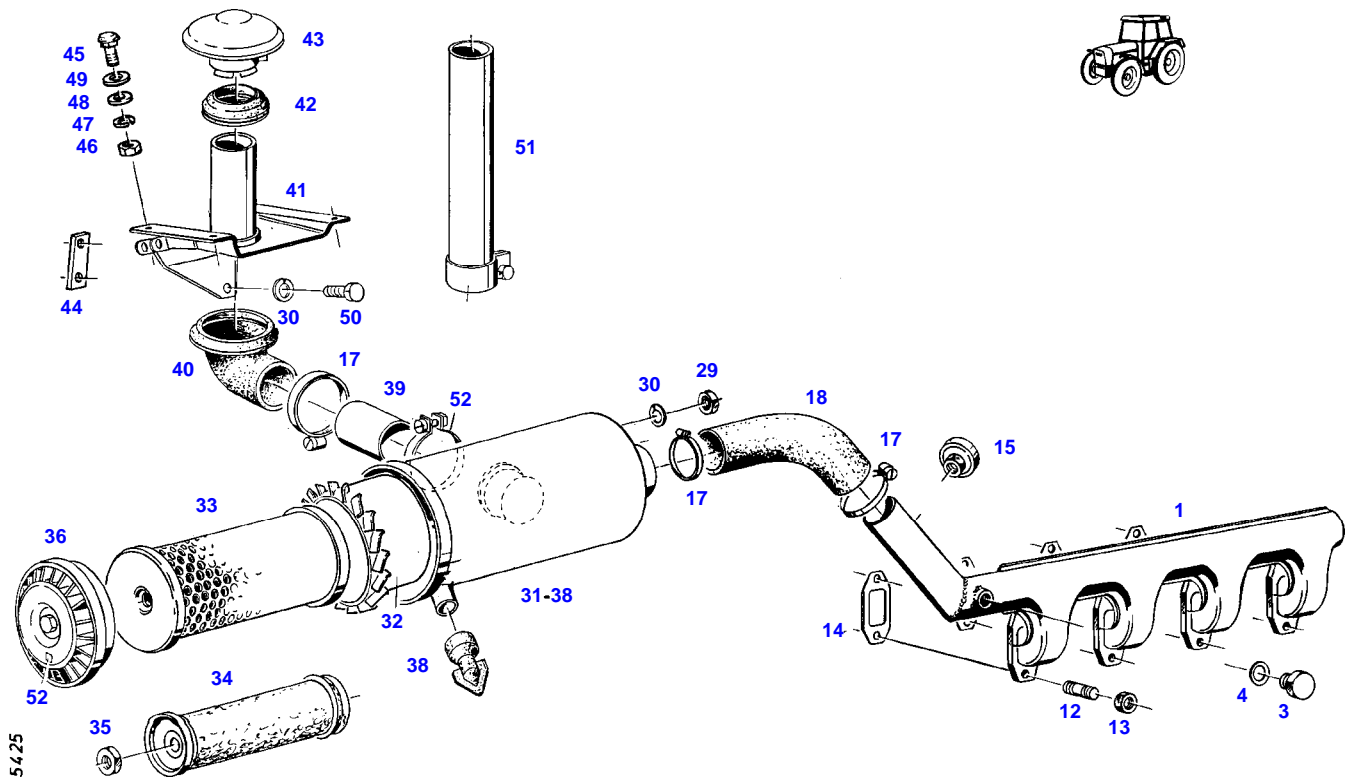

Item	Part Number	Qty	Description Comments	Technical Specification
			PICLON	
			--> 178/12999	
1	72355728	1	INTAKE MANIFOLD	
	72355729	1	INTAKE MANIFOLD AIR BRAKING SYSTEM	
3	72373975	1	SCREW	DIN 910 M20X1,5-ST
4	72376031	1	SEALING WASHER	DIN 7603 A20X24-CU
12	72373922	8	STUD BOLT	DIN 835-M10X25-8.8
13	72373015	8	NUT	DIN70615-M10-8-A3B
14	72332145	4	MOLDED SEAL	
15	72316876	1	MAINTENANCE SWITCH	
17	72373528	3	HOSE CLIP	
18	72393689	1	RUBBER ARCH	
29	72313268	4	NUT	DIN 934 M8-8A3L
30	72315053	6	SPLIT WASHER	FWN 65208-8-A3L
31	72348100	1	AIR FILTER ><31-38	
32	72329111	1	DIFFUSER	
33	72329734	1	MICRO-TOP CARTRIDGE	
34	72329735	1	SAFETY CARTRIDGE	
35	72372827	1	NUT	DIN 934 M16X1,5-10A3L
36	72329736	1	FLOOR	
38	72326122	1	DUST DISCHARGE VALVE	
39	72393687	1	CONNECTING PIPE	
40	72393688	1	BELLOWS	
41	72355730	1	AIR INTAKE	
42	72393690	1	SEALING RING	
43	72330730	1	RAIN CAP	
44	72393790	1	THREADED PLATE	
45	72373806	4	TRUSS HEAD SCREW	DIN 603 M6X16-A3L
46	72313266	5	NUT	DIN 934 M6-8A3L
47	72315052	4	SPLIT WASHER	FWN 65208-6-A3L
48	72311787	4	DISC	DIN 125-6,4-ST.A3L
49	72311788	4	DISC	DIN 125-8,4-ST.A3L
50	72315645	2	HEXAGONAL HEAD BOLT	DIN 933 M8 X 12-8.8A3L
51	72384104	1	CONNECTING PIPE	
52	72389314	1	ABSORPTION INDICATOR	
	72329737	1	PIPE CLAMP	
			<-- X458.648.500.000	

FARMER 308 (178/12001-14100)
4906

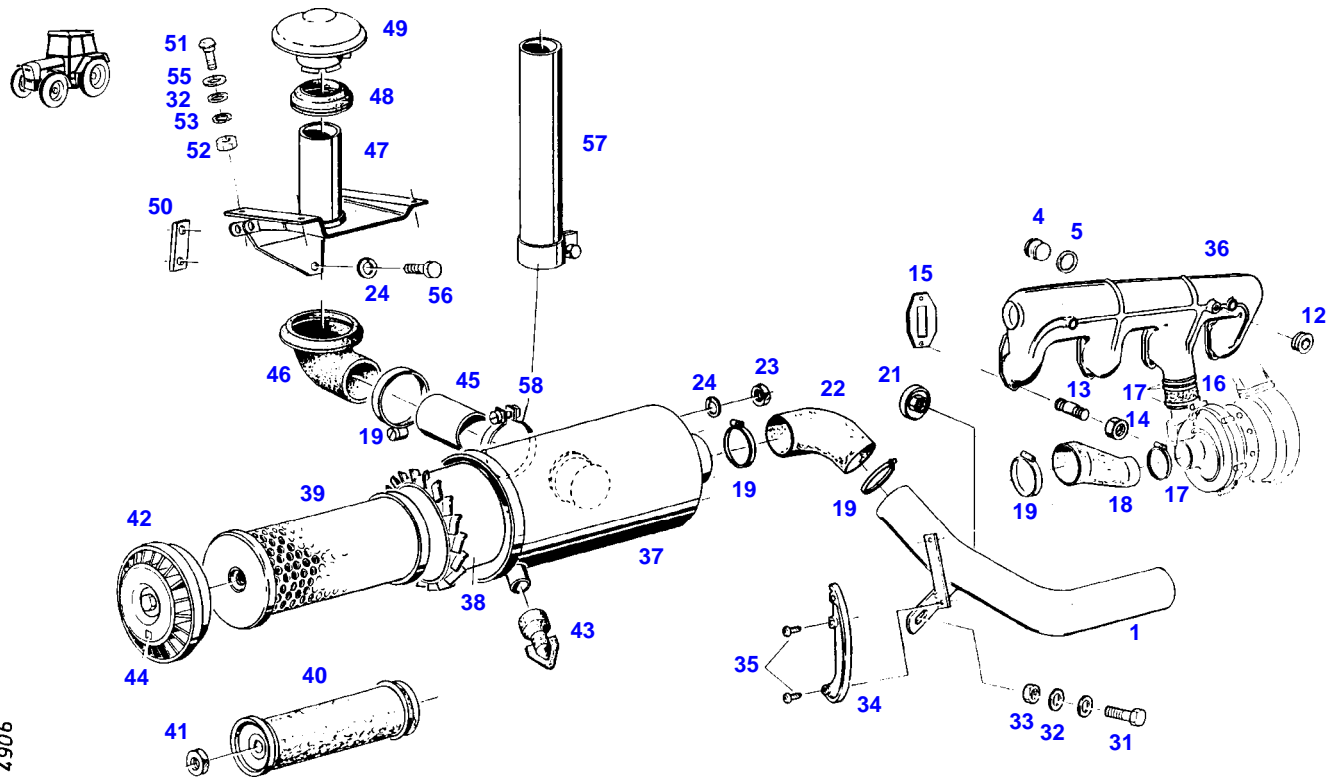

4906

Item	Part Number	Qty	Description Comments	Technical Specification
			PICLON	
			<-- 178/13000	
1	72356713	1	INTAKE MANIFOLD	
	72356715	1	INTAKE MANIFOLD AIR BRAKING SYSTEM	
4	72373975	1	SCREW	DIN 910 M20X1,5-ST
5	72376031	1	SEALING WASHER	DIN 7603 A20X24-CU
12	72315433	1	SCREW	DIN 906 M14X1,5-ST
13	72373922	8	STUD BOLT	DIN 835-M10X25-8.8
14	72373015	8	NUT	DIN70615-M10-8-A3B
15	72332145	4	MOLDED SEAL	
16	72332139	1	HOSE PIECE	
17	72311163	4	HOSE CLIP	
18	72395415	1	REDUCER	
19	72373528	4	HOSE CLIP	
21	72316876	1	MAINTENANCE SWITCH	
22	72395414	1	RUBBER ARCH	
23	72313268	4	NUT	DIN 934 M8-8A3L
24	72315053	6	SPLIT WASHER	FWN 65208-8-A3L
31	72315630	1	HEXAGONAL HEAD BOLT	DIN 933 M6X18-8.8A3L
32	72311787	5	DISC	DIN 125-6,4-ST.A3L
33	72313318	1	NUT	DIN6925-M6-8-A3L
34	72395417	1	SKID	
35	72315814	2	SCREW	DIN7976-ST4,8X16-F-A3L
36	72395914	1	INTAKE MANIFOLD	
37	72348100	1	AIR FILTER ><38-43	
38	72329111	1	DIFFUSER	
39	72329734	1	MICRO-TOP CARTRIDGE	
40	72329735	1	SAFETY CARTRIDGE	
41	72372827	1	NUT	DIN 934 M16X1,5-10A3L
42	72329736	1	FLOOR	
43	72326122	1	DUST DISCHARGE VALVE	
44	72409032	1	ABSORPTION INDICATOR	
45	72393687	1	CONNECTING PIPE	
46	72393688	1	BELLOWS	
47	72355730	1	AIR INTAKE	
48	72393690	1	SEALING RING	
49	72330730	1	RAIN CAP	
50	72393790	1	THREADED PLATE	
51	72373806	4	TRUSS HEAD SCREW	DIN 603 M6X16-A3L
52	72313266	5	NUT	DIN 934 M6-8A3L
53	72315052	4	SPLIT WASHER	FWN 65208-6-A3L
55	72311788	4	DISC	DIN 125-8,4-ST.A3L
56	72315645	2	HEXAGONAL HEAD BOLT	DIN 933 M8 X 12-8.8A3L
57	72384104	1	CONNECTING PIPE	
58	72329737	1	PIPE CLAMP <-- X548.648.500.000	

FARMER 308 (178/12001-14100)
5972

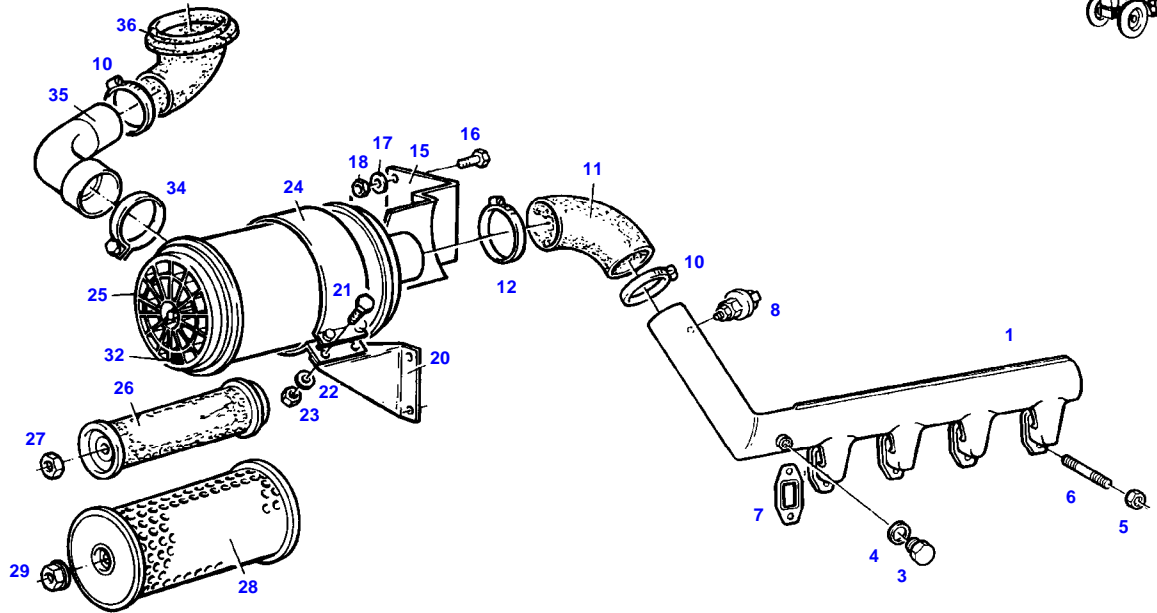

5972

Item	Part Number	Qty	Description Comments	Technical Specification
			PICO <-- 178/12530 --> 178/12999	
1	72355728	1	INTAKE MANIFOLD	
	72355729	1	INTAKE MANIFOLD AIR BRAKING SYSTEM	
3	72373975	1	SCREW	DIN 910 M20X1,5-ST
4	72376031	1	SEALING WASHER	DIN 7603 A20X24-CU
5	72373015	8	NUT	DIN70615-M10-8-A3B
6	72373922	8	STUD BOLT	DIN 835-M10X25-8.8
7	72332145	4	MOLDED SEAL	
8	72316876	1	MAINTENANCE SWITCH	
10	72373528	2	HOSE CLIP	
11	72393709	1	RUBBER ARCH	
12	72311171	1	HOSE CLIP	
15	72356745	1	RETAINER	
16	72315645	3	HEXAGONAL HEAD BOLT	DIN 933 M8 X 12-8.8A3L
17	72315053	3	SPLIT WASHER	FWN 65208-8-A3L
18	72313268	3	NUT	DIN 934 M8-8A3L
20	72395446	1	SUPPORT	
21	72315629	2	HEXAGONAL HEAD BOLT	DIN 933 M6 X 12-8.8A3L
22	72315052	2	SPLIT WASHER	FWN 65208-6-A3L
23	72313266	2	NUT	DIN 934 M6-8A3L
24	72348547	1	PIPE CLAMP	
25	72348545	1	AIR FILTER ><25-29	
26	72332126	1	SAFETY CARTRIDGE	
27	72339030	1	COLLAR NUT	
28	72332441	1	MICRO-TOP CARTRIDGE	
29	72372827	1	NUT	DIN 934 M16X1,5-10A3L
32	72389314	1	ABSORPTION INDICATOR	
34	72373517	1	CLAMPING CLIP	
35	72356718	1	ELBOW FITTING	
36	72393688	1	BELLOWS	

FARMER 308 (178/12001-14100)
4907

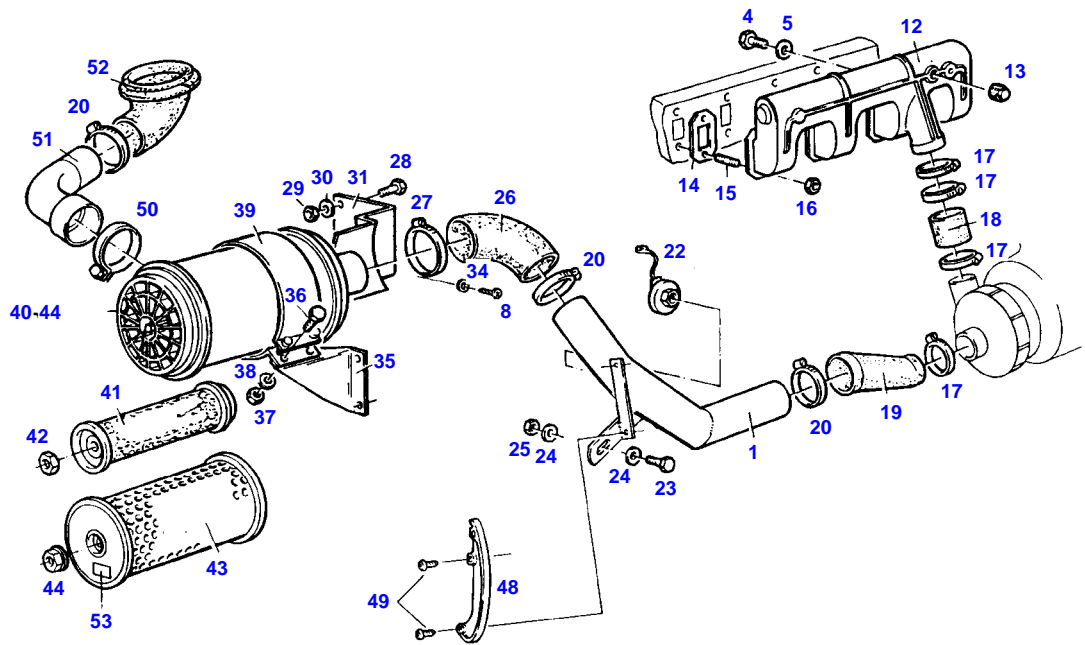

4907

Item	Part Number	Qty	Description Comments	Technical Specification
			PICO	
			<-- 178/13000	
1	72356713	1	INTAKE MANIFOLD	
	72356715	1	INTAKE MANIFOLD AIR BRAKING SYSTEM	
4	72373975	1	SCREW	DIN 910 M20X1,5-ST
5	72376031	1	SEALING WASHER	DIN 7603 A20X24-CU
12	72395914	1	INTAKE MANIFOLD	
13	72315433	1	SCREW	DIN 906 M14X1,5-ST
14	72332145	4	MOLDED SEAL	
15	72373922	8	STUD BOLT	DIN 835-M10X25-8.8
16	72373015	8	NUT	DIN70615-M10-8-A3B
17	72311163	4	HOSE CLIP	
18	72332139	1	HOSE PIECE	
19	72395415	1	REDUCER	
20	72373528	3	HOSE CLIP	
22	72316876	1	MAINTENANCE SWITCH	
23	72315630	1	HEXAGONAL HEAD BOLT	DIN 933 M6X18-8.8A3L
24	72311787	1	DISC	DIN 125-6,4-ST.A3L
25	72313318	1	NUT	DIN6925-M6-8-A3L
26	72395421	1	RUBBER ARCH	
27	72311171	1	HOSE CLIP	
28	72315645	3	HEXAGONAL HEAD BOLT	DIN 933 M8 X 12-8.8A3L
29	72313268	3	NUT	DIN 934 M8-8A3L
30	72315053	3	SPLIT WASHER	FWN 65208-8-A3L
31	72356745	1	RETAINER	
35	72395446	1	SUPPORT	
36	72315629	2	HEXAGONAL HEAD BOLT	DIN 933 M6 X 12-8.8A3L
37	72313266	2	NUT	DIN 934 M6-8A3L
38	72315052	2	SPLIT WASHER	FWN 65208-6-A3L
39	72348547	1	PIPE CLAMP	
40	72348545	1	AIR FILTER ><41-44	
41	72332126	1	SAFETY CARTRIDGE	
42	72339030	1	COLLAR NUT	
43	72332441	1	MICRO-TOP CARTRIDGE	
44	72372827	1	NUT	DIN 934 M16X1,5-10A3L
48	72395417	1	SKID	
49	72315814	2	SCREW	DIN7976-ST4,8X16-F-A3L
50	72373517	1	CLAMPING CLIP	
51	72356718	1	ELBOW FITTING	
52	72393688	1	BELLOWS	
53	72409032	1	ABSORPTION INDICATOR	

FARMER 308 (178/12001-14100)
4270

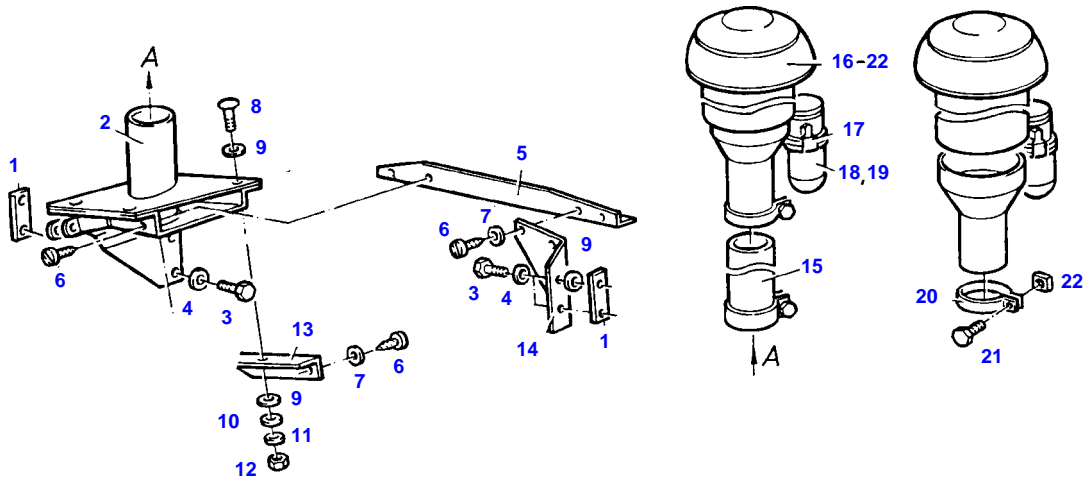

4270

Item	Part Number	Qty	Description Comments	Technical Specification
			PICO <-- 178/12530 --> 178/12999	
1	72393790	2	THREADED PLATE	
2	72356719	1	AIR INTAKE	
3	72315645	4	HEXAGONAL HEAD BOLT	DIN 933 M8 X 12-8.8A3L
4	72315053	4	SPLIT WASHER	FWN 65208-8-A3L
5	72395424	1	STIFFENING PLATE	
6	72315789	6	SCREW	DIN 7981 ST4,8X9,5-C-H-A3
7	72311785	4	DISC	DIN 125-5,3-ST.A3L
8	72373806	4	TRUSS HEAD SCREW	DIN 603 M6X16-A3L
9	72311788	9	DISC	DIN 125-8,4-ST.A3L
10	72311787	4	DISC	DIN 125-6,4-ST.A3L
11	72315052	4	SPLIT WASHER	FWN 65208-6-A3L
12	72313266	4	NUT	DIN 934 M6-8A3L
13	72395425	1	GUSSET PLATE	
14	72395423	1	GUSSET PLATE	
15	72384104	1	CONNECTING PIPE	
16	72348546	1	CYCLONE AIR CLEANER ><17-22	
17	72321921	1	CATCH	
18	72330736	1	FUNNEL	
19	72320204	1	CONTAINER	
20	72328628	1	PIPE CLAMP	
21	72328615	1	HEXAGONAL HEAD BOLT	
22	72372784	1	SQUARE NUT	DIN 557 M8-5

FARMER 308 (178/12001-14100)
5994

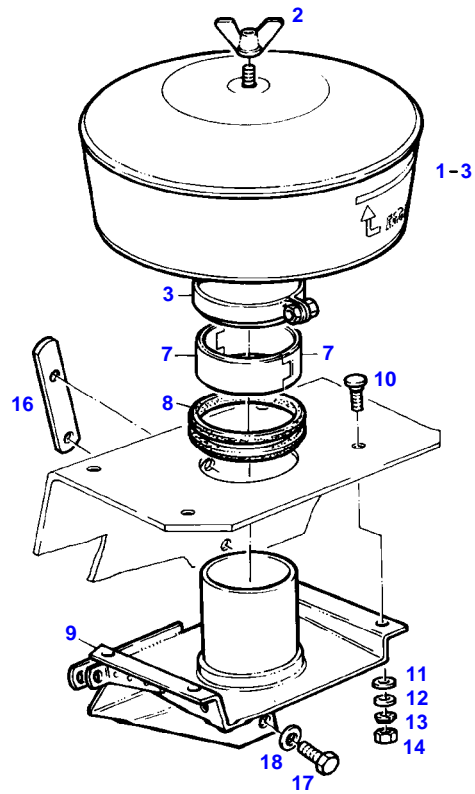

7594

Item	Part Number	Qty	Description Comments	Technical Specification
			PICO <--178/12530	
1	72348552	1	PRE-CLEANER >>1-3	
	72311582	1	DUST CUP	
2	72313238	1	WING NUT	
3	72332464	1	HOSE CLIP	
7	72395448	2	HALF-BEARING	
8	72393690	1	SEALING RING	
9	72356750	1	AIR INTAKE	
10	72373806	4	TRUSS HEAD SCREW	DIN 603 M6X16-A3L
11	72311788	4	DISC	DIN 125-8,4-ST.A3L
12	72311787	4	DISC	DIN 125-6,4-ST.A3L
13	72315052	4	SPLIT WASHER	FWN 65208-6-A3L
14	72313266	4	NUT	DIN 934 M6-8A3L
16	72393790	1	THREADED PLATE	
17	72315645	2	HEXAGONAL HEAD BOLT	DIN 933 M8 X 12-8.8A3L
18	72315053	2	SPLIT WASHER	FWN 65208-8-A3L

FARMER 308 (178/12001-14100)
4908

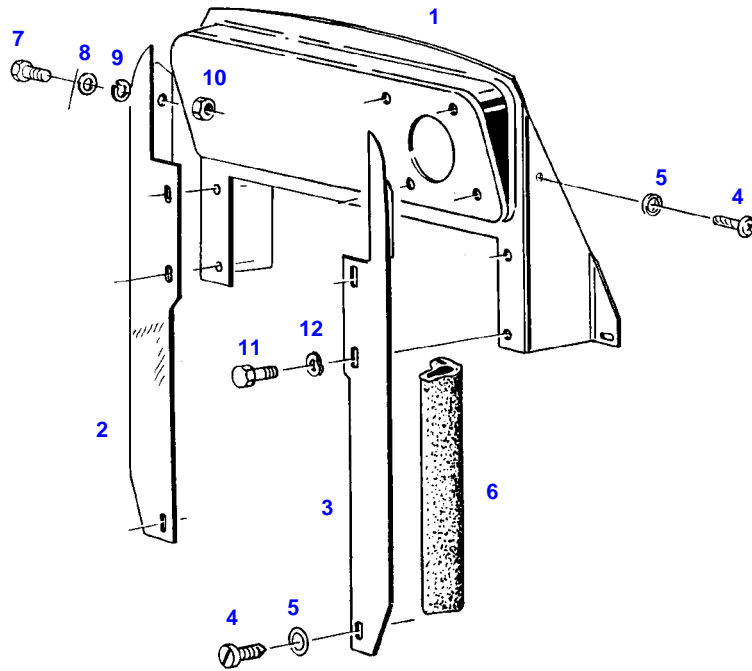

4908

Thank you so much for reading.
Please click the “Buy Now!”
button below to download the
complete manual.



After you pay.

You can download the most
perfect and complete manual in
the world immediately.

Our support email:

ebooklibonline@outlook.com