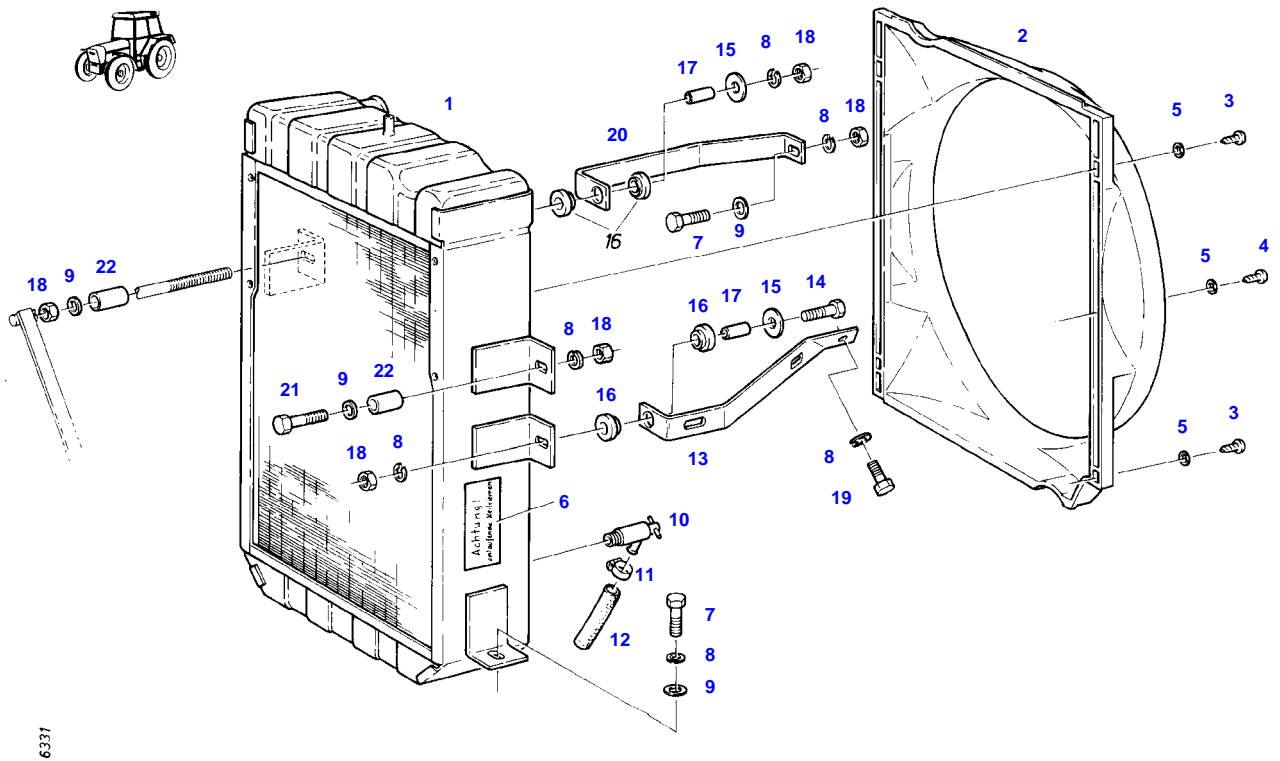

TABLE OF CONTENT

Page Number	Page Title	Page Reference
01-000-TOC	ENGINE, FUEL AND EXHAUST SYSTEM	01-000-TOC
02-000-TOC	AXLES	02-000-TOC
03-000-TOC	STEERING SYSTEM	03-000-TOC
04-000-TOC	DRIVE TRAIN SYSTEM	04-000-TOC
05-000-TOC	COMPRESSED AIR SYSTEM	05-000-TOC
06-000-TOC	HYDRAULIC SYSTEM	06-000-TOC
07-000-TOC	ELECTRICAL SYSTEM	07-000-TOC
08-000-TOC	CAB	08-000-TOC
09-000-TOC	AIR CONDITIONING AND HEATING SYSTEM	09-000-TOC
10-000-TOC	CHASSIS	10-000-TOC
11-000-TOC	WHEELS	11-000-TOC
12-000-TOC	IMPLEMENT LIFT SYSTEM FRONT	12-000-TOC
13-000-TOC	IMPLEMENT LIFT SYSTEM REAR	13-000-TOC
14-000-TOC	FRONT/REAR LOADERS	14-000-TOC
15-000-TOC	ATTACHMENTS	15-000-TOC
16-000-TOC	ACCESSORIES	16-000-TOC

FARMER 309 (186/14601-30000)
6331



Item	Part Number	Qty	Description Comments	Technical Specification
			--> 186/20000	
1	72348232	1	RADIATOR AIR BRAKE SUPPLY EQUIPEMENT RANGE OF TEMPERATURE 1 <-- G186.205.050.010 1X AIR BRAKE SUPPLY EQUIPEMENT <>	
	72315663	1	HEXAGONAL HEAD BOLT	DIN 933 M8X40-8.8A3L
	72395450	1	BRACKET	
	72400314	1	BUSH	
	72348553	1	RADIATOR TEMP.RANGE 2 / 1+2 WITH AIR BRAKE TEMP.RANGE 1 WITH AIR CONDITION TEMP.RANGE 1 WITH AIR CONDITION KLIMAANLAGE 1 M.KLIMAANLAGE	
2	72393668	1	FAN COVER	
3	72315818	4	SCREW	DIN7976-ST4,2X25-C-A3L
4	72315787	2	SCREW	DIN 7981 B4,2X16-A3L
5	72311817	6	DISC	DIN9021-4,3-140HV-A3L
6	72386100	2	WARNING SIGN D	
	72388085	2	WARNING SIGN GB	
	72388086	2	WARNING SIGN F	
	72388087	2	WARNING SIGN I	
	72388088	2	WARNING SIGN E	
7	72315650	3	HEXAGONAL HEAD BOLT	DIN 933 M8 X 20-8.8A3L
8	72315053	7	SPLIT WASHER	FWN 65208-8-A3L
9	72311788	5	DISC	DIN 125-8,4-ST.A3L
10	72378063	1	RELIEF VALVE	DIN71401-CM14X1,5KEG
11	72438345	1	HOSE CLIP	
12	72389310	1	HOSE	
13	72395409	1	BRACE	
14	72315660	1	HEXAGONAL HEAD BOLT	DIN 933 M8X35-8.8A3L
15	72311888	2	DISC	
16	72312479	4	UNIVERSAL SPOUT	
17	72310718	2	BUSH	
18	72313268	5	NUT	DIN 934 M8-8A3L
19	72315653	1	HEXAGONAL HEAD BOLT	DIN 933 M8 X 25-8.8A3L
20	72393671	1	BRACE	
21	72315650	1	HEXAGONAL HEAD BOLT AIR BRAKE SUPPLY EQUIPEMENT RANGE OF TEMPERATURE 1 AIR BRAKE SUPPLY EQUIPEMENT	DIN 933 M8 X 20-8.8A3L
	72315663	1	HEXAGONAL HEAD BOLT TEMP.RANGE 2 / 1+2 WITH AIR BRAKE TEMP.RANGE 1 WITH AIR CONDITION TEMP.RANGE 1 WITH AIR CONDITION KLIMAANLAGE 1 M.KLIMAANLAGE	DIN 933 M8X40-8.8A3L
22	72400314	2	BUSH TEMP.RANGE 2 / 1+2 WITH AIR BRAKE TEMP.RANGE 1 WITH AIR CONDITION TEMP.RANGE 1 WITH AIR CONDITION KLIMAANLAGE 1 M.KLIMAANLAGE	

FARMER 309 (186/14601-30000)
7487

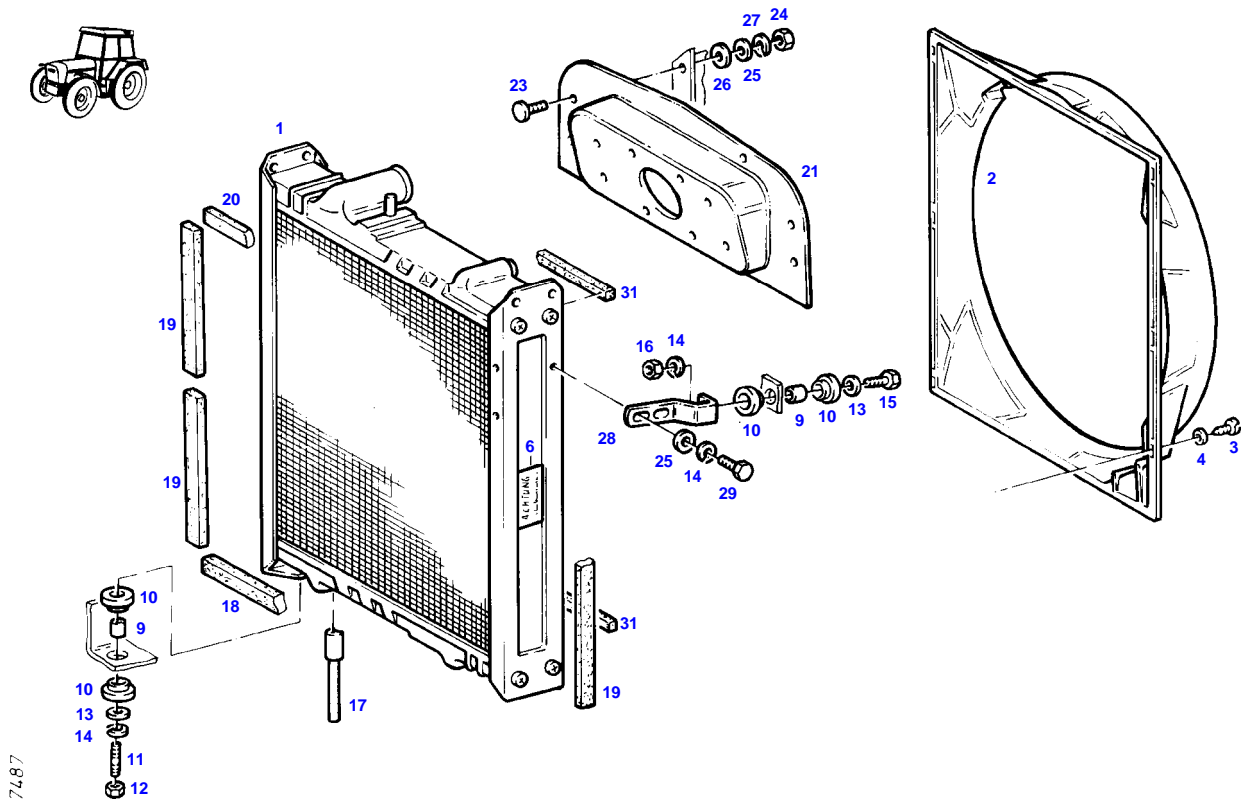

Item	Part Number	Qty	Description Comments	Technical Specification
			<-- 186/20001	
1	72348555	1	RADIATOR	
2	72395456	1	FAN COVER	
3	72315818	6	SCREW	DIN7976-ST4,2X25-C-A3L
4	72311817	6	DISC	DIN9021-4,3-140HV-A3L
6	72379109	1	MARKING PLATE	FWN66556-35X68-SCHUTZVORR.N.OE
9	72310718	4	BUSH	
10	72312479	8	UNIVERSAL SPOUT	
11	72313772	2	STUD BOLT	DIN 939 M8X30-8.8
12	72313320	2	NUT	DIN6925-M8-8-A3L
13	72311824	4	DISC	DIN9021-8,4-140HV-A3L
14	72315053	4	SPLIT WASHER	FWN 65208-8-A3L
15	72315660	2	HEXAGONAL HEAD BOLT	DIN 933 M8X35-8.8A3L
16	72313268	2	NUT	DIN 934 M8-8A3L
17	72397310	1	DRAINAGE PIPING	
18	72310182	1	STRAP	
19	72397315	4	STRAP	
20	72395459	1	STRAP	
21	72397306	1	BARRIER WALL	
23	72373806	5	TRUSS HEAD SCREW	DIN 603 M6X16-A3L
24	72313266	5	NUT	DIN 934 M6-8A3L
25	72311787	7	DISC	DIN 125-6,4-ST.A3L
26	72311788	5	DISC	DIN 125-8,4-ST.A3L
27	72315052	5	SPLIT WASHER	FWN 65208-6-A3L
28	72397309	2	HOLDER	
29	72315642	4	HEXAGONAL HEAD BOLT	DIN 933 M8 X 16-8.8A3L
31	72450560	1	SEALING STRIP 2X 470MM CUT TO LENGTH	

FARMER 309 (186/14601-30000)
6336

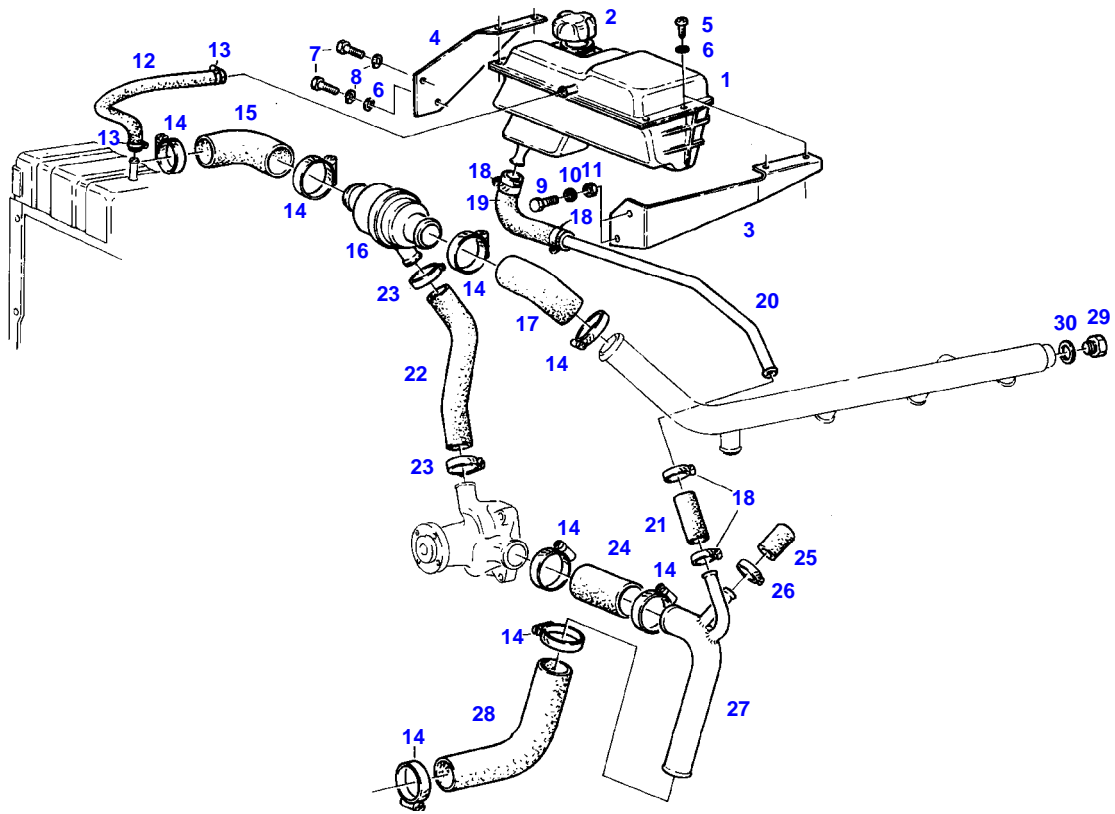

6336

Item	Part Number	Qty	Description Comments	Technical Specification
			--> 186/20000	
1	72316897	1	EXPANSION TANK <>	
	72409370	1	CAP	
	72438345	1	HOSE CLIP	
2	72348672	1	COLLER LOCKING	
3	72392987	1	BRACKET AIR BRAKE SUPPLY EQUIPEMENT RANGE OF TEMPERATURE 1 AIR BRAKE SUPPLY EQUIPEMENT	
	72395450	1	BRACKET TEMP.RANGE 2 / 1+2 WITH AIR BRAKE TEMP.RANGE 1 WITH AIR CONDITION TEMP.RANGE 1 WITH AIR CONDITION KLIMAANLAGE 1 M.KLIMAANLAGE	
4	72392988	1	BRACKET	
5	72315821	4	SCREW	DIN7976-ST6,3X19-C-A3L
6	72311822	5	DISC	DIN9021-6,4-140HV-A3L
7	72315629	2	HEXAGONAL HEAD BOLT	DIN 933 M6 X 12-8.8A3L
8	72315052	2	SPLIT WASHER	FWN 65208-6-A3L
9	72315642	2	HEXAGONAL HEAD BOLT	DIN 933 M8 X 16-8.8A3L
10	72315053	2	SPLIT WASHER	FWN 65208-8-A3L
11	72313268	2	NUT	DIN 934 M8-8A3L
12	72622024	1	PRESSURE HOSE 1X 185MM CUT TO LENGTH	L=0,50M 8X3,5-FWN65911
13	72438345	2	HOSE CLIP	
14	72311162	8	HOSE CLIP	
15	72393666	1	RUBBER ARCH	
16	72380193	1	THERMOSTAT	75GR+-2GR
17	72392140	1	RUBBER ARCH	
18	72311166	4	HOSE CLIP	
19	72435869	1	RUBBER ARCH	
20	72392830	1	PIPE	
21	72450412	1	HOSE 1X 50MM CUT TO LENGTH	L=1000 18X3,5 R DIN 73411
22	72436027	1	HOSE 1X 120MM CUT TO LENGTH	L=320 DIN73411-25X3,5 R
23	72311167	2	HOSE CLIP	
24	72393672	1	REDUCER	
25	72404925	1	CAP	
26	72311166	1	HOSE CLIP	
27	72357308	1	SUCTION LINE	
28	72395412	1	RUBBER ARCH	
29	72315802	1	SCREW	DIN 7604 AM22X1,5-ST
30	72315101	1	SEALING WASHER	DIN 7603 A22X27-CU

FARMER 309 (186/14601-30000)
7488

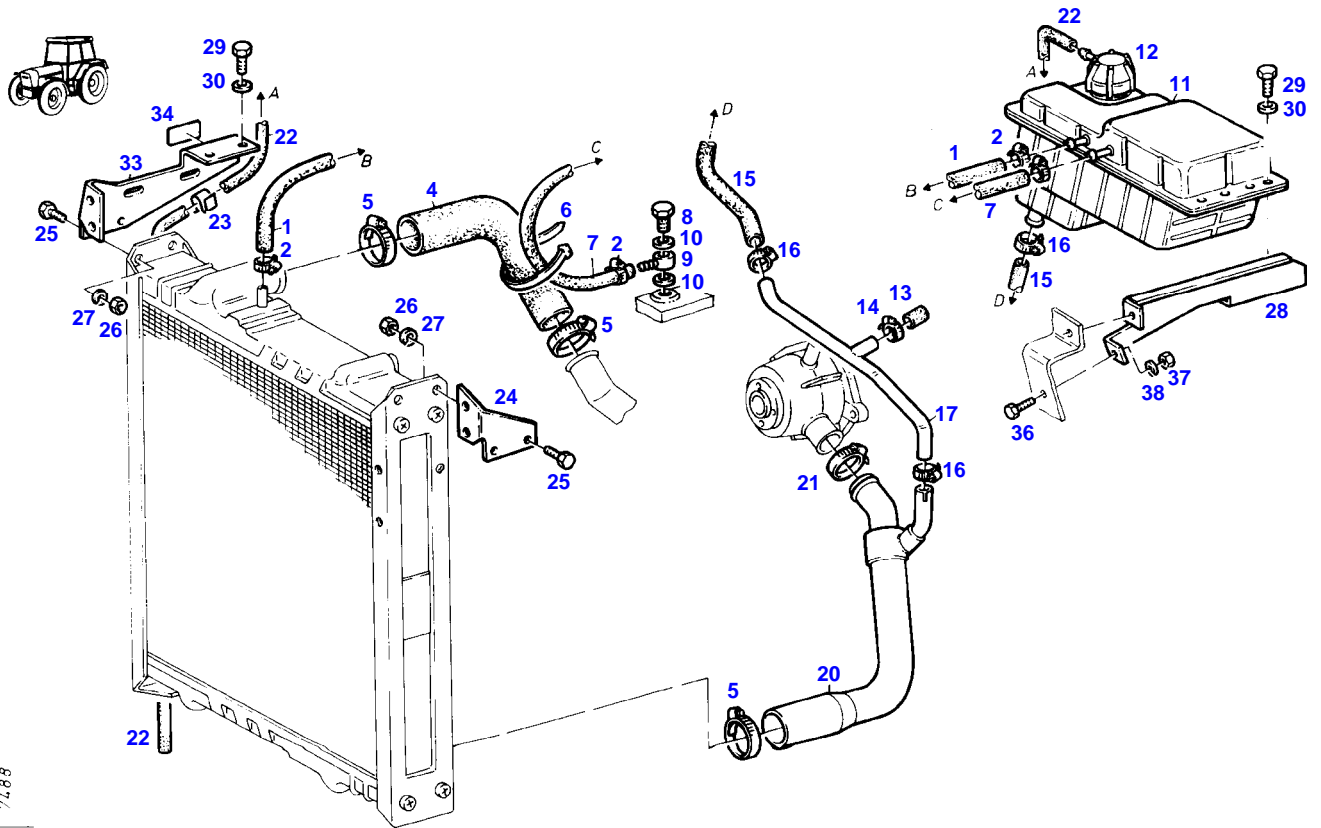

Item	Part Number	Qty	Description Comments	Technical Specification
			<-- 186/20001	
1	72622024	1	PRESSURE HOSE 190 MM CUT TO LENGTH	L=0,50M 8X3,5-FWN65911
2	72438345	4	HOSE CLIP	
4	72395457	1	RUBBER ARCH	
5	72311170	3	HOSE CLIP	
6	72316915	1	CABLE STRAP	FWN 66650 B290X4,8-SW
7	72450289	1	PRESSURE HOSE 510 MM CUT TO LENGTH	L=550 FWN 66041-M4
8	72315806	1	BANJO BOLT	DIN 7643-6-3-A3L
9	72377528	1	RING HOSE NIPPLE	FWN65910-A-DN4
10	72315088	2	SEALING WASHER	DIN 7603 A10X13,5-CU
11	72316897	1	EXPANSION TANK	
12	72310924	1	COLLER LOCKING	
13	72404925	1	CAP	
14	72311166	1	HOSE CLIP	
15	72435869	1	RUBBER ARCH	
16	72311166	3	HOSE CLIP	
17	72357764	1	PIPE	
20	72395458	1	COOLANT LINE	
21	72311162	1	HOSE CLIP	
22	72442422	1	HOSE 1000 MM CUT TO LENGTH	L=1500MM
23	72312049	3	HOSE RETAINER	
24	72397308	1	RETAINER	
25	72315642	2	HEXAGONAL HEAD BOLT	DIN 933 M8 X 16-8.8A3L
26	72313268	6	NUT	DIN 934 M8-8A3L
27	72315053	6	SPLIT WASHER	FWN 65208-8-A3L
28	72397312	1	BRACKET	
29	72315821	4	SCREW	DIN7976-ST6,3X19-C-A3L
30	72311822	6	DISC	DIN9021-6,4-140HV-A3L
33	72395461	1	RETAINER	
34	72397318	1	MARKING PLATE	
36	72315629	1	HEXAGONAL HEAD BOLT	DIN 933 M6 X 12-8.8A3L
37	72313266	1	NUT	DIN 934 M6-8A3L
38	72315052	1	SPLIT WASHER	FWN 65208-6-A3L

FARMER 309 (186/14601-30000)
7153

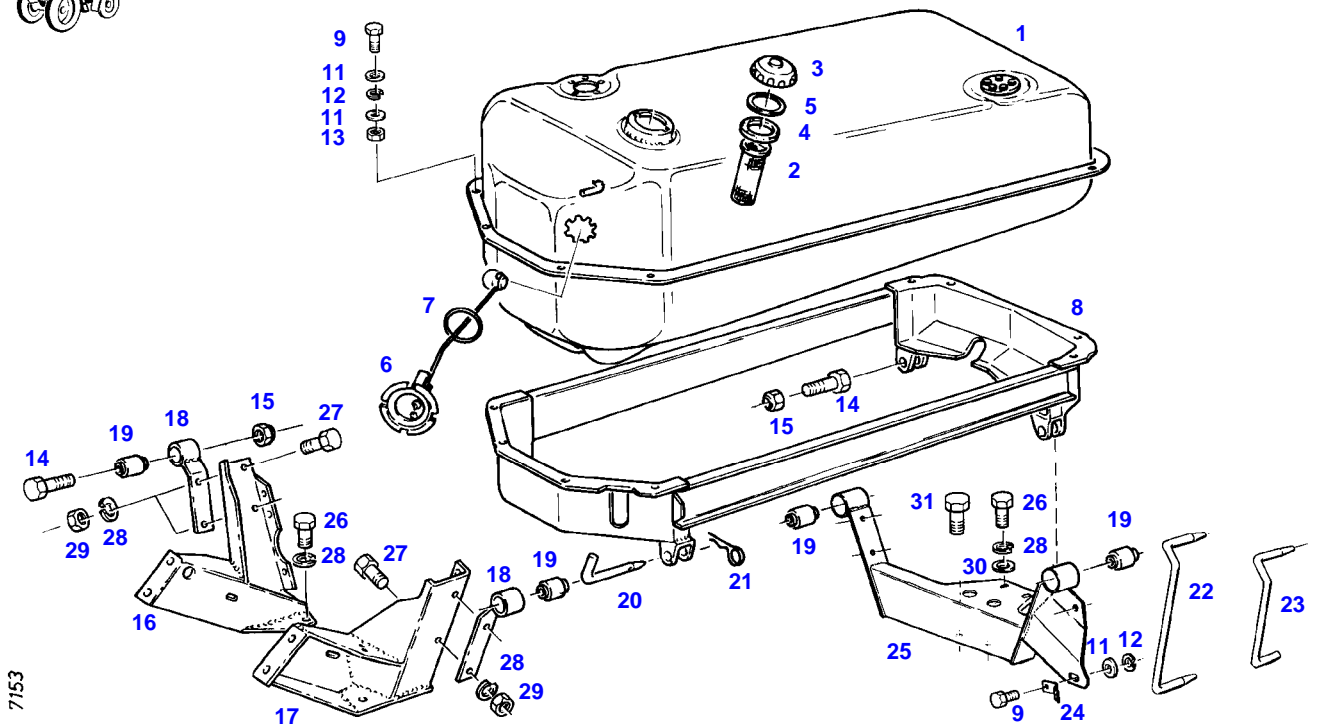

7153

Item	Part Number	Qty	Description Comments	Technical Specification
			--> 186/20000	
1	72349985	1	FUEL TANK <>	
	72348556	1	FUEL LEVEL SENSOR	
2	72433112	1	STRAINER	60X100-MS
3	72380143	1	FUEL CAP KOEHLER	M.BELUEF
	72348297	1	FUEL CAP LOCKABLE BLAU ><4	
4	72330725	1	SEAL BLAU	
	72312304	1	RUBBER SEAL KOEHLER	
5	72330726	1	SEAL BLAU	
6	72613041	1	FUEL LEVEL SENSOR --> 186/15059 --> 162/8455	
	72348556	1	FUEL LEVEL SENSOR <-- 186/15060 <-- G148.200.060.011	
7	72315169	1	SEALING WASHER	
8	72357106	1	TANK FRAME	
9	72315626	7	HEXAGONAL HEAD BOLT	DIN 933-M6 X 16-8.8-A3L
11	72311822	12	DISC	DIN9021-6,4-140HV-A3L
12	72315052	8	SPLIT WASHER	FWN 65208-6-A3L
13	72313266	8	NUT	DIN 934 M6-8A3L
14	72315719	2	HEXAGONAL HEAD BOLT	DIN 933 M12X60-8.8A3L
15	72313325	2	NUT	DIN 980-VM12-8-A3L
16	72356748	1	BRACKET	
17	72356749	1	BRACKET	
18	72356758	2	SUPPORT ARM	
19	72310644	4	RUBBER BUSHING	
20	72404932	1	BEARING PIN	
21	72311183	1	HAIR COTTER PIN	DIN 11024-4-A3L
22	72393676	1	BEARING PIN	
23	72393681	1	BEARING PIN	
24	72393680	1	LEAF SPRING	
25	72355727	1	CROSSMEMBER	
26	72315642	8	HEXAGONAL HEAD BOLT	DIN 933 M8 X 16-8.8A3L
27	72315657	4	HEXAGONAL HEAD BOLT	DIN 933 M8 X 30-8.8A3L
28	72315053	12	SPLIT WASHER	FWN 65208-8-A3L
29	72313268	4	NUT	DIN 934 M8-8A3L
30	72311788	2	DISC	DIN 125-8,4-ST.A3L
31	72315675	2	HEXAGONAL HEAD BOLT	DIN 933 M10X16-8.8A3L

FARMER 309 (186/14601-30000)
7683

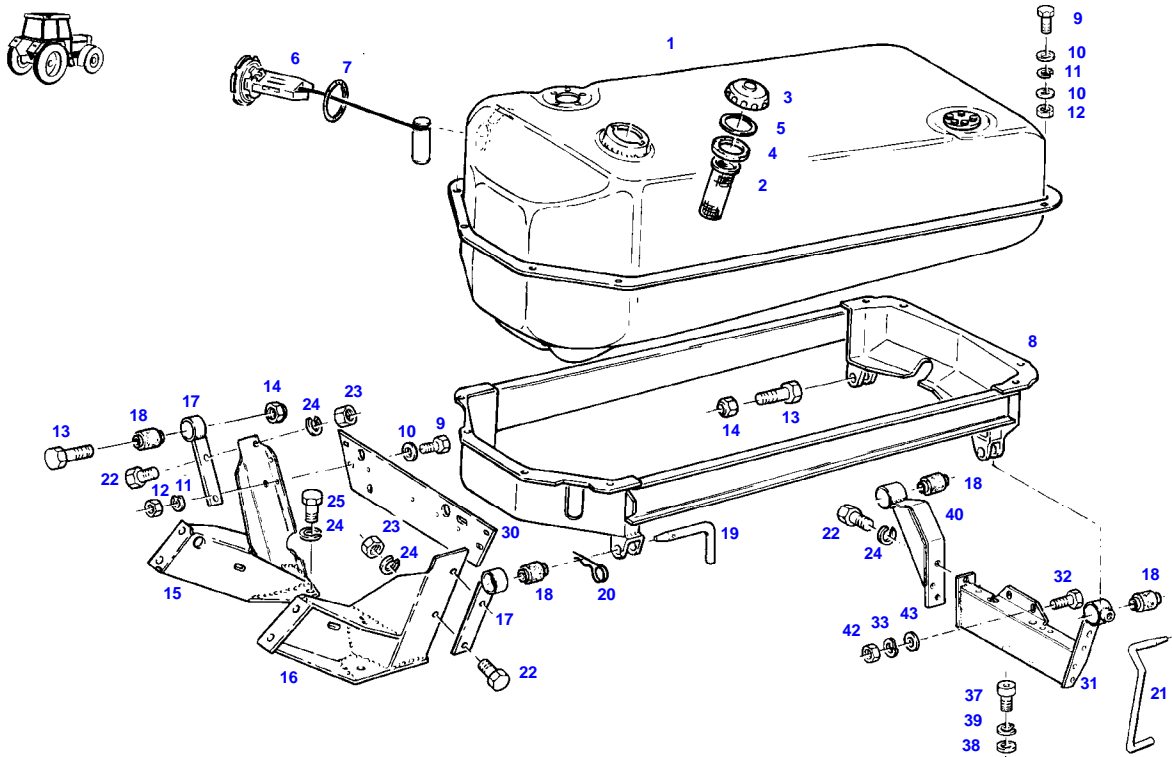

7683

Item	Part Number	Qty	Description Comments	Technical Specification
			<-- 186/20001	
1	72349985	1	FUEL TANK	
2	72433112	1	STRAINER	60X100-MS
3	72380143	1	FUEL CAP KOEHLER	M.BELUEF
	72348297	1	><4 FUEL CAP LOCKABLE BLAU	
			><4+5	
4	72330725	1	SEAL BLAU	
	72312304	1	RUBBER SEAL KOEHLER	
5	72330726	1	SEAL	
6	72348556	1	FUEL LEVEL SENSOR	
			><7 <-- G148.200.060.011	
7	72315169	1	SEALING WASHER	
8	72357106	1	TANK FRAME	
9	72315626	12	HEXAGONAL HEAD BOLT	DIN 933-M6 X 16-8.8-A3L
10	72311822	20	DISC	DIN9021-6,4-140HV-A3L
11	72315052	13	SPLIT WASHER	FWN 65208-6-A3L
12	72313266	13	NUT	DIN 934 M6-8A3L
13	72315719	2	HEXAGONAL HEAD BOLT	DIN 933 M12X60-8.8A3L
14	72313325	2	NUT	DIN 980-VM12-8-A3L
15	72356748	1	BRACKET	
16	72356749	1	BRACKET	
17	72356758	2	SUPPORT ARM	
18	72310644	4	RUBBER BUSHING	
19	72407288	2	BEARING PIN	
20	72311183	2	HAIR COTTER PIN	DIN 11024-4-A3L
21	72393681	1	BEARING PIN	
22	72315657	5	HEXAGONAL HEAD BOLT	DIN 933 M8 X 30-8.8A3L
23	72313268	4	NUT	DIN 934 M8-8A3L
24	72315053	13	SPLIT WASHER	FWN 65208-8-A3L
25	72315642	8	HEXAGONAL HEAD BOLT	DIN 933 M8 X 16-8.8A3L
30	72397321	1	SHEET METAL	
31	72363528	1	CROSSMEMBER	
32	72315689	2	HEXAGONAL HEAD BOLT	DIN 933 M10X35-8.8A3L
33	72317122	2	SPRING WASHER	DIN 137 B10-MECH.VZK
37	72374066	2	SOCKET HEAD BOLT	DIN 912 M12X20-8.8
38	72311804	2	DISC	DIN 433-13-ST.A3L
39	72315055	2	SPLIT WASHER	FWN 65208-12-A3L
40	72357109	1	SUPPORT ARM	
42	72313272	2	NUT	DIN 934 M10-8A3L
43	72311789	2	DISC	DIN 125-10,5-ST.A3L

FARMER 309 (186/14601-30000)
6662

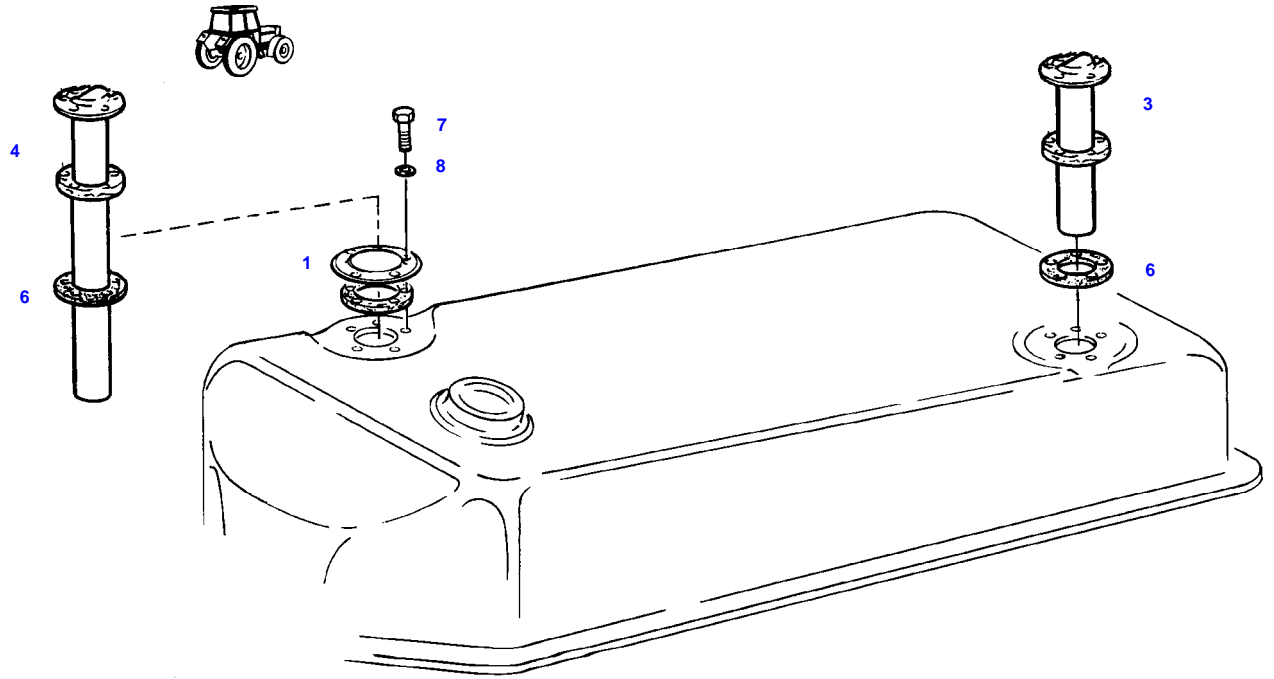

6662

Item	Part Number	Qty	Description Comments	Technical Specification
			--> 186/20000	
1	72409022	2	FLANGE	
3	72380157	1	FUEL LEVEL SENSOR BOARD COMPUTER	
4	72380156	1	FUEL LEVEL SENSOR BOARD COMPUTER	
6	72376132	2	SEALING WASHER	
7	72315619	10	HEXAGONAL HEAD BOLT	DIN 933 M5X16-8.8A3L
8	72376017	10	SEALING WASHER	DIN 7603-A5X7,5-CU

FARMER 309 (186/14601-30000)
40845

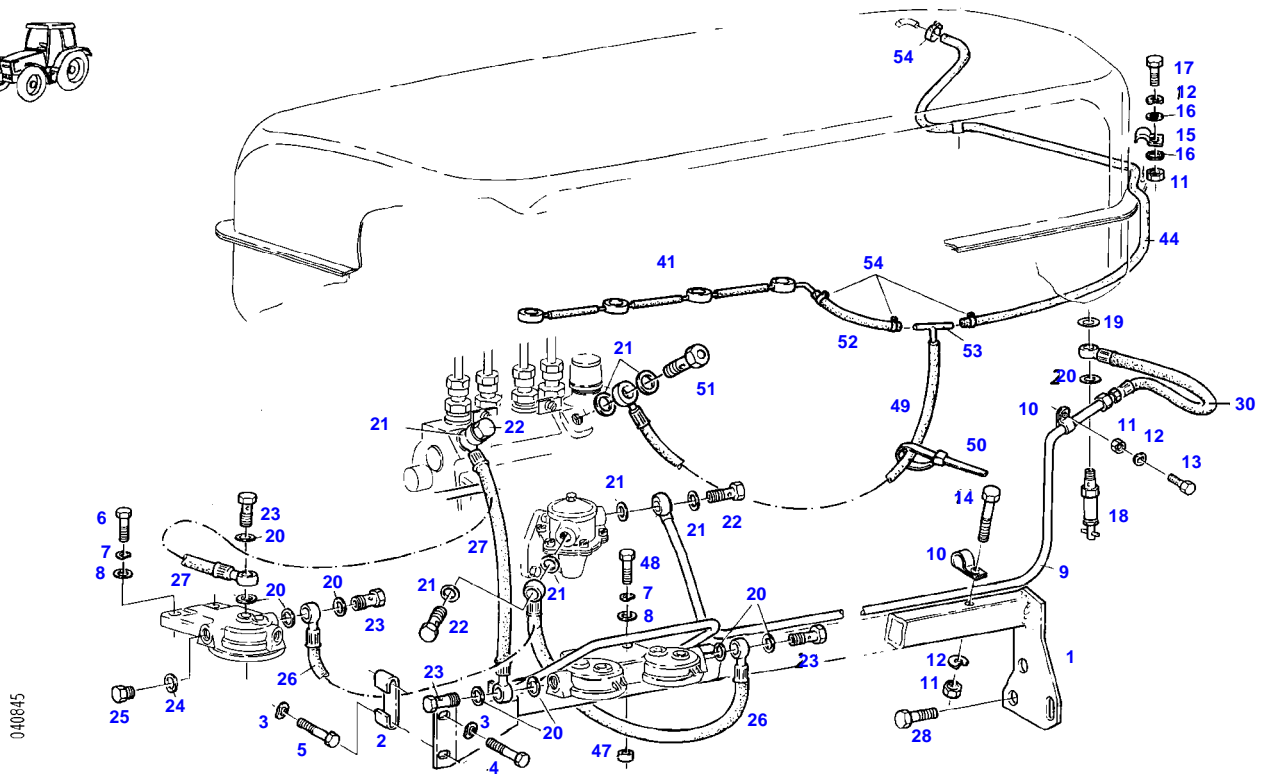

040845

Item	Part Number	Qty	Description Comments	Technical Specification
			--> 186/20000	
1	72356743	1	RETAINER	
2	72399913	1	HOLDER	
3	72317122	2	SPRING WASHER	DIN 137 B10-MECH.VZK
4	72315689	1	HEXAGONAL HEAD BOLT	DIN 933 M10X35-8.8A3L
5	72315691	1	HEXAGONAL HEAD BOLT	DIN 933 M10X40-8.8A3L
6	72315657	2	HEXAGONAL HEAD BOLT	DIN 933 M8 X 30-8.8A3L
7	72315053	2	SPLIT WASHER	FWN 65208-8-A3L
8	72311824	2	DISC	DIN9021-8,4-140HV-A3L
9	72356707	1	TUBING	
10	72311241	2	PIPE CLAMP	
11	72313266	3	NUT	DIN 934 M6-8A3L
12	72315052	3	SPLIT WASHER	FWN 65208-6-A3L
13	72315626	1	HEXAGONAL HEAD BOLT	DIN 933-M6 X 16-8.8-A3L
	72311787	1	DISC NOT ILLUSTRATED	DIN 125-6,4-ST.A3L
14	72315637	1	HEXAGONAL HEAD BOLT	DIN 933 M6X45-8.8A3L
15	72398941	2	FASTENING COLLAR	
16	72311822	4	DISC	DIN9021-6,4-140HV-A3L
17	72315631	2	HEXAGONAL HEAD BOLT	DIN 933 M6 X 20-8.8A3L
18	72380159	1	FUEL SHUT-OFF VALVE	
19	72315093	1	SEALING WASHER	DIN 7603 A12X18-CU
20	72315095	7	SEALING WASHER	DIN 7603 A14X20-CU
21	72315095	6	SEALING WASHER	DIN 7603 A14X20-CU
22	72315808	2	BANJO BOLT	DIN 7643-10-3-A3L
23	72315808	3	BANJO BOLT	DIN 7643-10-3-A3L
24	72315095	2	SEALING WASHER	DIN 7603 A14X20-CU
25	72315799	2	PLUG	DIN 7604 AM14X1,5-A3L
26	72356760	1	FUEL LINE	
27	72355537	1	FUEL LINE	
28	72374490	2	HEXAGONAL HEAD BOLT	DIN 933 M14X20-8.8
	72374493	2	HEXAGONAL HEAD BOLT	DIN 933 M14X30-8.8
30	72357312	1	HOSE LINE	
41	72332525	1	LEAKAGE OIL LINE	
44	72435830	1	PRESSURE HOSE 1100 MM CUT TO LENGTH	L=2100
47	72311848	2	DISC	
48	72315660	2	HEXAGONAL HEAD BOLT	DIN 933 M8X35-8.8A3L
49	72356761	1	FUEL LINE	
50	72316916	2	CABLE STRAP	FWN 66650 B175X4-SW
51	72380268	1	BLEED AND DRAIN VALVE	
52	72450301	1	PRESSURE HOSE 260 MM CUT TO LENGTH	L=1000
53	72380023	1	TEE FITTING	
54	72438345	5	HOSE CLIP	

FARMER 309 (186/14601-30000)
7689

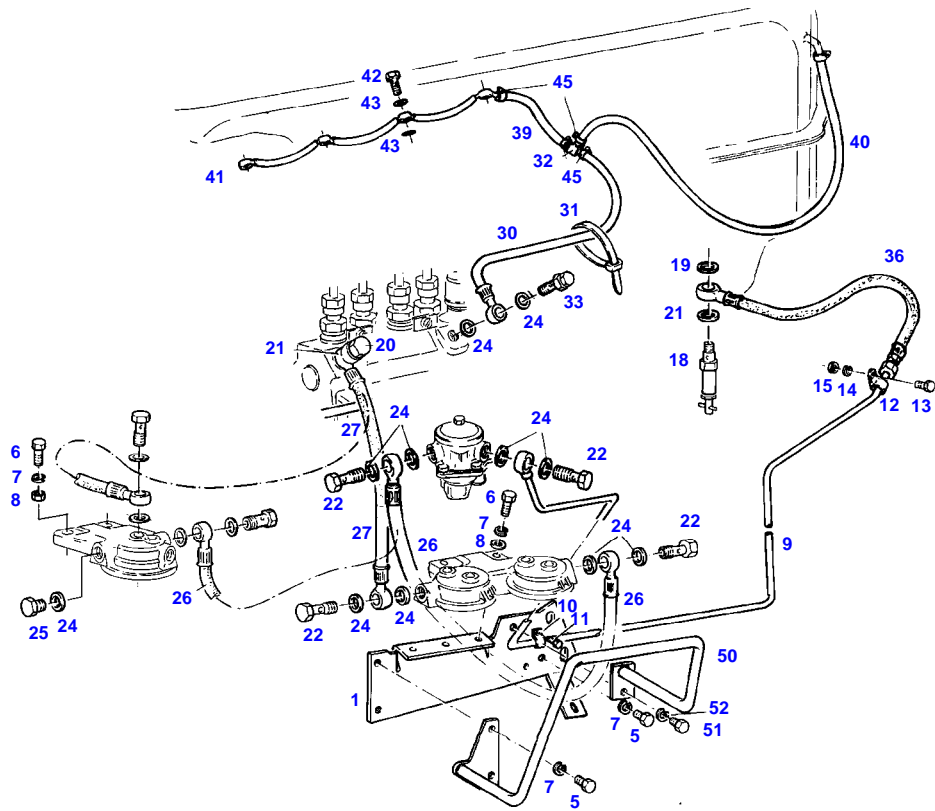

7689

Item	Part Number	Qty	Description Comments	Technical Specification
			<-- 186/20001	
1	72357112	1	FILTER RETAINER	
			<>	
	72310699	1	BUSH	
	72374969	1	SCREW	DIN7976-ST4,8X19-C-A3L
5	72315642	3	HEXAGONAL HEAD BOLT	DIN 933 M8 X 16-8.8A3L
6	72315657	2	HEXAGONAL HEAD BOLT	DIN 933 M8 X 30-8.8A3L
7	72315053	5	SPLIT WASHER	FWN 65208-8-A3L
8	72311824	2	DISC	DIN9021-8,4-140HV-A3L
9	72356707	1	TUBING	
10	72311241	1	PIPE CLAMP	
11	72315819	1	SCREW	DIN7976-ST4,8X13-C-A3L
	72311785	1	DISC	DIN 125-5,3-ST.A3L
12	72311241	1	PIPE CLAMP	
13	72315626	1	HEXAGONAL HEAD BOLT	DIN 933-M6 X 16-8.8-A3L
14	72315052	1	SPLIT WASHER	FWN 65208-6-A3L
15	72313266	1	NUT	DIN 934 M6-8A3L
18	72380159	1	FUEL SHUT-OFF VALVE	
19	72315093	1	SEALING WASHER	DIN 7603 A12X18-CU
20	72310187	1	DOUBLE BOLT	
21	72315095	2	SEALING WASHER	DIN 7603 A14X20-CU
22	72315808	4	BANJO BOLT	DIN 7643-10-3-A3L
24	72315095	14	SEALING WASHER	DIN 7603 A14X20-CU
25	72315799	2	PLUG	DIN 7604 AM14X1,5-A3L
26	72356760	1	FUEL LINE	
27	72356760	1	FUEL LINE	
30	72356761	1	FUEL LINE	
31	72316916	2	CABLE STRAP	FWN 66650 B175X4-SW
32	72380023	1	TEE FITTING	
33	72380268	1	BLEED AND DRAIN VALVE	
36	72356762	1	FUEL LINE	
39	72450301	1	PRESSURE HOSE 260 MM CUT TO LENGTH	L=1000
40	72450301	1	PRESSURE HOSE 750 MM CUT TO LENGTH	L=1000
41	72332525	1	LEAKAGE OIL LINE	
42	72342985	4	SCREW	
43	72315084	8	SEALING WASHER	DIN 7603 A6X10-CU
45	72438345	4	HOSE CLIP	
	72438345	1	HOSE CLIP	
50	72357121	1	PROTECTION BAR	
51	72315642	1	HEXAGONAL HEAD BOLT	DIN 933 M8 X 16-8.8A3L
52	72315053	1	SPLIT WASHER	FWN 65208-8-A3L

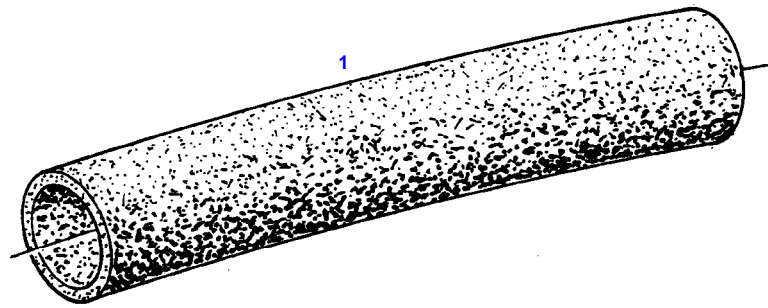

8555

Item	Part Number	Qty	Description Comments	Technical Specification
			RAPE SEED OIL METHYLATED ESTER	
1	72436293	1	HEAT SHRINK TUBING 1X 2500 MM CUT TO LENGTH	L=2600
	72436294	X	HEAT SHRINK TUBING 1X 3000 MM CUT TO LENGTH	L=3100
	72436295	1	HEAT SHRINK TUBING 1X 2000 MM CUT TO LENGTH	L=2100

FARMER 309 (186/14601-30000)
4952

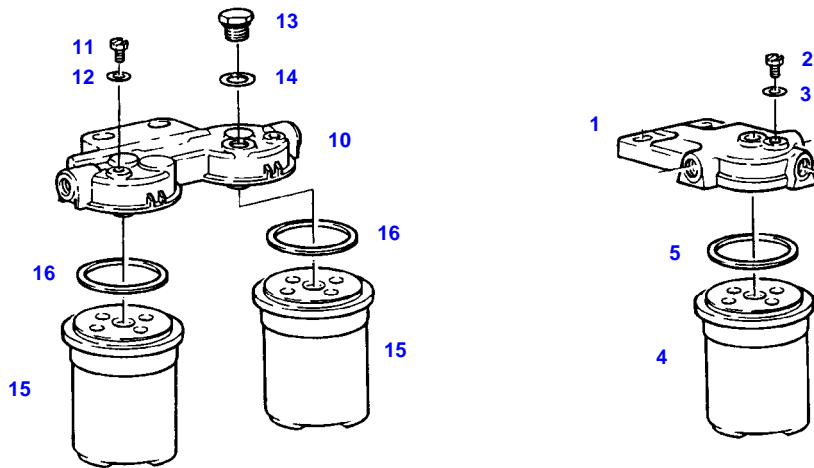

4952

Item	Part Number	Qty	Description Comments	Technical Specification
1	72615599	1	FILTER LID ><2,3	
2	72323290	1	BLEED SCREW	
3	72315084	1	SEALING WASHER	DIN 7603 A6X10-CU
4	72416928	1	FILTER BOX ><5	
5	72314995	1	RUBBER RING PARALLEL-FILTER	
10	72380173	1	PARALLEL FILTER BOSCH ><11-16 <-- X810.190.166.000 1X <>	
	72416928	2	FILTER BOX	
	72451307	1	COVER KNECHT ><11,12 <>	PARALLELFILT.
	72416928	2	FILTER BOX	
11	72323290	2	BLEED SCREW BOSCH	
	72314699	2	BLEED SCREW KNECHT	
12	72315084	2	SEALING WASHER BOSCH	DIN 7603 A6X10-CU
	72315086	2	SEALING WASHER KNECHT	DIN 7603 A8X11,5-CU
13	72326250	1	SCREW BOSCH	
14	72315095	1	SEALING WASHER BOSCH	DIN 7603 A14X20-CU
15	72416928	2	FILTER BOX ><16	
16	72314995	2	RUBBER RING	

FARMER 309 (186/14601-30000)
4907

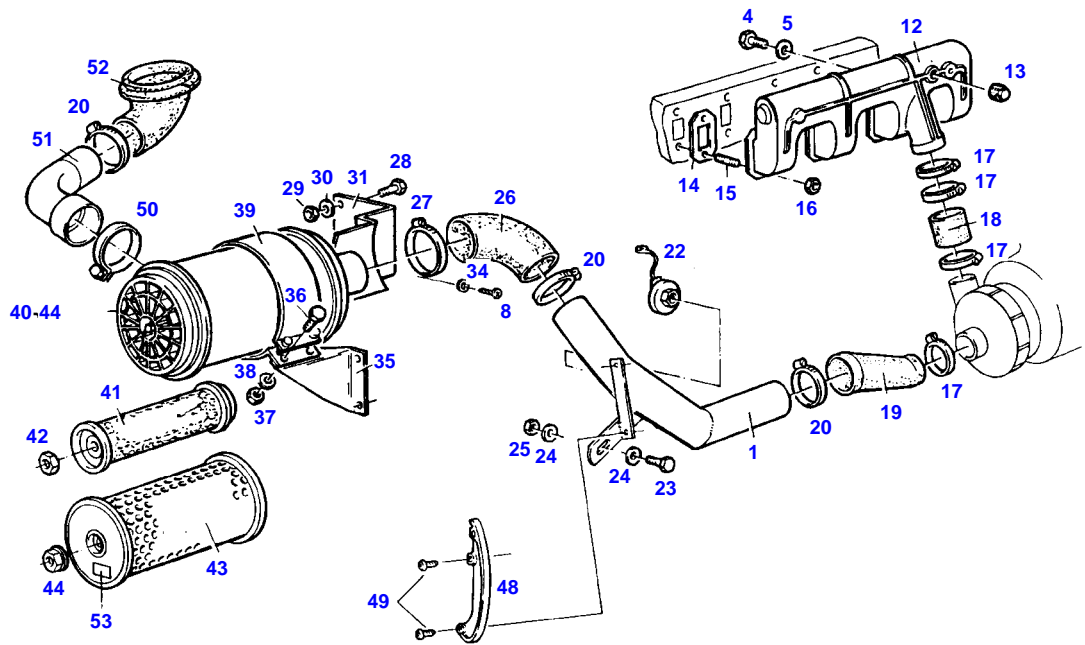

4907

Item	Part Number	Qty	Description Comments	Technical Specification
			--> 186/20000	
1	72356713	1	INTAKE MANIFOLD	
	72356715	1	INTAKE MANIFOLD	
			AIR BRAKING SYSTEM	
4	72373975	1	SCREW	DIN 910 M20X1,5-ST
5	72376031	1	SEALING WASHER	DIN 7603 A20X24-CU
8			NOT USED	
12	72395914	1	INTAKE MANIFOLD	
13	72315433	1	SCREW	DIN 906 M14X1,5-ST
14	72332145	4	MOLDED SEAL	
15	72373922	8	STUD BOLT	DIN 835-M10X25-8.8
16	72373015	8	NUT	DIN70615-M10-8-A3B
17	72311163	4	HOSE CLIP	
18	72332139	1	HOSE PIECE	
19	72395415	1	REDUCER	
20	72373528	3	HOSE CLIP	
22	72316876	1	MAINTENANCE SWITCH	
23	72315630	1	HEXAGONAL HEAD BOLT	DIN 933 M6X18-8.8A3L
24	72311787	1	DISC	DIN 125-6,4-ST.A3L
25	72313318	1	NUT	DIN6925-M6-8-A3L
26	72395421	1	RUBBER ARCH	
27	72311171	1	HOSE CLIP	
28	72315645	3	HEXAGONAL HEAD BOLT	DIN 933 M8 X 12-8.8A3L
29	72313268	3	NUT	DIN 934 M8-8A3L
30	72315053	3	SPLIT WASHER	FWN 65208-8-A3L
31	72356745	1	RETAINER	
34			NOT USED	
35	72395446	1	SUPPORT	
36	72315629	2	HEXAGONAL HEAD BOLT	DIN 933 M6 X 12-8.8A3L
37	72313266	2	NUT	DIN 934 M6-8A3L
38	72315052	2	SPLIT WASHER	FWN 65208-6-A3L
39	72348547	1	PIPE CLAMP	
40	72348545	1	AIR FILTER	
			>>40-44	
41	72332126	1	SAFETY CARTRIDGE	
42	72339030	1	COLLAR NUT	
43	72332441	1	MICRO-TOP CARTRIDGE	
44	72372827	1	NUT	DIN 934 M16X1,5-10A3L
48	72395417	1	SKID	
49	72315814	2	SCREW	DIN7976-ST4,8X16-F-A3L
50	72373517	1	CLAMPING CLIP	
51	72356718	1	ELBOW FITTING	
52	72393688	1	BELLOWS	
53	72395449	1	ABSORPTION INDICATOR	

FARMER 309 (186/14601-30000)
5994

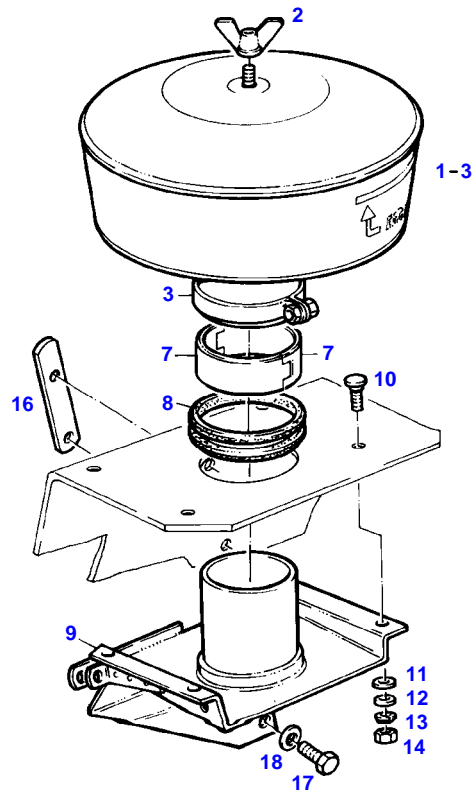

7594

Thank you so much for reading.
Please click the “Buy Now!”
button below to download the
complete manual.



After you pay.

You can download the most
perfect and complete manual in
the world immediately.

Our support email:

ebooklibonline@outlook.com