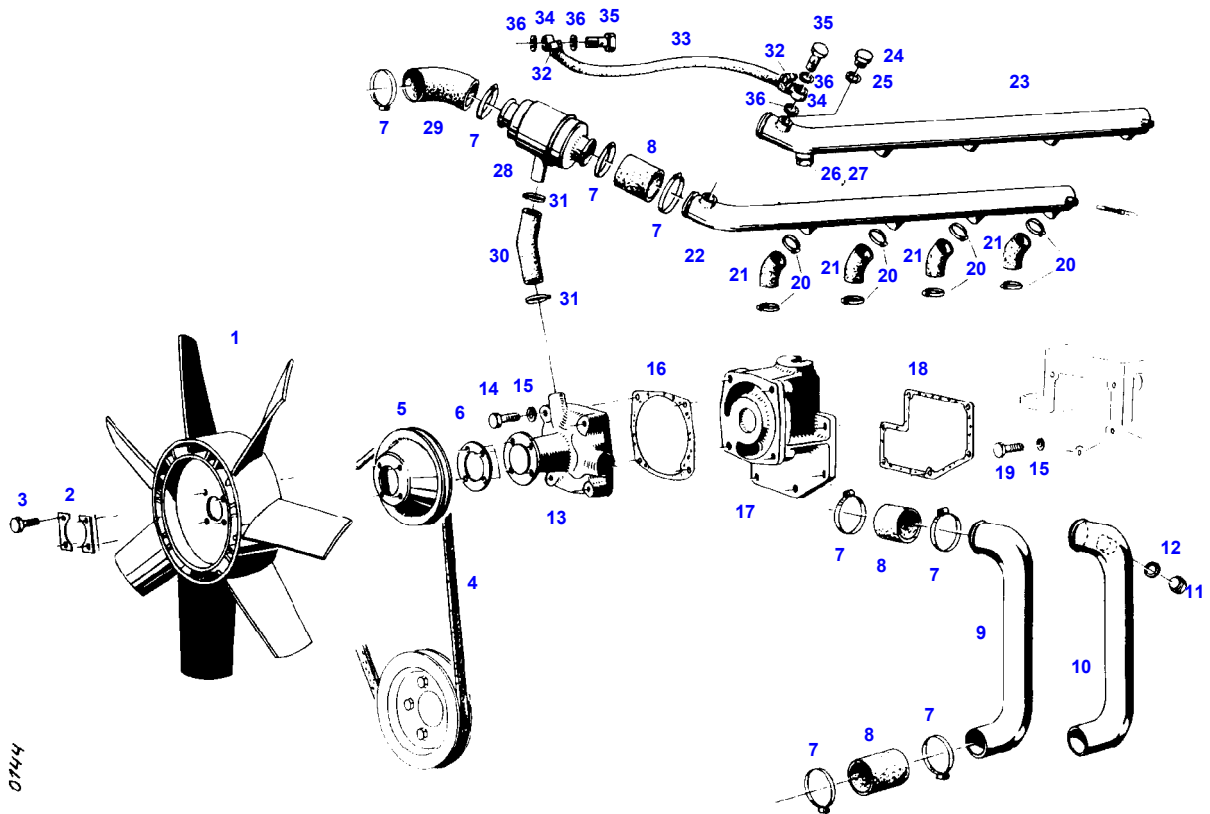

**TABLE OF CONTENT**

<b>Page Number</b>	<b>Page Title</b>	<b>Page Reference</b>
01-000-TOC	ENGINE, FUEL AND EXHAUST SYSTEM	01-000-TOC
02-000-TOC	AXLES	02-000-TOC
03-000-TOC	STEERING SYSTEM	03-000-TOC
04-000-TOC	DRIVE TRAIN SYSTEM	04-000-TOC
05-000-TOC	COMPRESSED AIR SYSTEM	05-000-TOC
06-000-TOC	HYDRAULIC SYSTEM	06-000-TOC
07-000-TOC	ELECTRICAL SYSTEM	07-000-TOC
08-000-TOC	CAB	08-000-TOC
09-000-TOC	CHASSIS	09-000-TOC
10-000-TOC	WHEELS	10-000-TOC
11-000-TOC	IMPLEMENT LIFT SYSTEM FRONT	11-000-TOC
12-000-TOC	IMPLEMENT LIFT SYSTEM REAR	12-000-TOC
13-000-TOC	FRONT/REAR LOADERS	13-000-TOC
14-000-TOC	ATTACHMENTS	14-000-TOC
15-000-TOC	ACCESSORIES	15-000-TOC

FARMER 105 (258/10601-99999)  
144



Item	Part Number	Qty	Description Comments	Technical Specification
			<b>CENTRIFUGAL PUMP PIPE &lt;-- 258/10601</b>	
1	72337468	1	FAN	
	72337468	1	FAN TROPICAL VERSION --> 258/20000	
	72380199	1	FAN TROPICAL VERSION <-- 258/20001	450/7
2	72327020	2	LOCK PLATE	
3	72315650	4	HEXAGONAL HEAD BOLT NOT NEEDED WITH AIR BRAKE --> 258/20000	DIN 933 M8 X 20-8.8A3L
	72315653	4	HEXAGONAL HEAD BOLT NOT NEEDED WITH AIR BRAKE <-- 258/20001	DIN 933 M8 X 25-8.8A3L
	72315660	4	HEXAGONAL HEAD BOLT TROPICAL VERSION <-- 258/20001	DIN 933 M8X35-8.8A3L
4			SEE ELECTRICAL SYSTEM ALTERNATOR ASSY.	
5	72327206	1	V BELT SHEAVE NOT NEEDED WITH AIR BRAKE	
	72327206	1	V BELT SHEAVE TROPICAL VERSION --> 258/20000	
	72399923	1	V BELT SHEAVE TROPICAL VERSION <-- 258/20001	
6	72394835	1	DISC NOT USED AT TROPICAL VERSION <-- 258/20001	
7	72311162	8	HOSE CLIP	
8	72450416	1	HOSE 3X 60MM CUT TO LENGTH	L=120 DIN73411-35X
9	72389308	1	SUCTION LINE NOT NEEDED WITH HEATING 105 S --> 258/20000	
	72360673	1	SUCTION LINE HEATING 105 S --> 258/20000 <> <>	
	72315097	1	SEALING WASHER	DIN 7603 A16X20-CU
	72402196	1	TUBE FITTING	
	72389308	1	SUCTION LINE TROPICAL VERSION	
10	72360673	1	SUCTION LINE 105 LS --> 258/20000	
11	72315800	1	SCREW NOT NEEDED WITH HEATING	DIN7604 AM16X1,5-ST-A3L
12	72315097	1	SEALING WASHER NOT NEEDED WITH HEATING	DIN 7603 A16X20-CU
13			NO LONGER AVAILABLE ENG.NO. --> 226.4.13498 <-- F281.200.610.010 1X	

Item	Part Number	Qty	Description Comments	Technical Specification
	72340133	1	CENTRIFUGAL PUMP ENG.NO. <-- 226.4.13499	
	72328687	1	REPAIR KIT ENG.NO. --> 226.4.13498 <-- F281.200.610.010 1X	
	72340135	1	REPAIR KIT ENG.NO. <-- 226.4.13499 <-- F281.200.610.010 1X	
	72328682	1	FACE SEAL ENG.NO. --> 226.4.13498 <-- F281.200.610.010 1X	
	72340137	1	FACE SEAL ENG.NO. <-- 226.4.13499	
	72340139	1	COUNTER RING ENG.NO. <-- 226.4.13499	
	72340140	1	IMPELLER ENG.NO. <-- 226.4.13499	
14	72315659	4	HEXAGONAL HEAD BOLT	DIN 933 M8X35-8.8
15	72315053	10	SPLIT WASHER	FWN 65208-8-A3L
16	72328678	1	SEAL	
17	72328671	1	INTERMEDIATE PIECE	
18			SEE CRANKCASE	
19	72315653	6	HEXAGONAL HEAD BOLT	DIN 933 M8 X 25-8.8A3L
20	72311167	8	HOSE CLIP	
21	72399869	4	RUBBER ARCH	
22	72355068	1	PRESSURE LINE --> 258/11210 <-- H258.207.050.020	
	72359328	1	PRESSURE LINE HEATING --> 258/11210	
23	72360674	1	PRESSURE LINE <-- 258/11211 <> 24-27 <>	
	72374934	1	SCREW	DIN 7604 AM8X1-ST
	72315086	1	SEALING WASHER	DIN 7603 A8X11,5-CU
	72315800	1	SCREW	DIN7604 AM16X1,5-ST-A3L
	72315097	1	SEALING WASHER	DIN 7603 A16X20-CU
	72337051	2	PIPE CLAMP <-- 258/14809 NOT ILLUSTRATED	
	72337052	2	PLATE LINK <-- 258/14809 NOT ILLUSTRATED	
24	72374934	1	SCREW <-- 258/13782	DIN 7604 AM8X1-ST
25	72315086	1	SEALING WASHER <-- 258/13782	DIN 7603 A8X11,5-CU
26	72315800	1	SCREW <-- 258/13782	DIN7604 AM16X1,5-ST-A3L
27	72315097	1	SEALING WASHER <-- 258/13782	DIN 7603 A16X20-CU
28	72380193	1	THERMOSTAT	75GR+-2GR
29	72399871	1	RUBBER ARCH	
30	72436027	1	HOSE 1X 130MM	L=320 DIN73411-25X3,5 R
31	72311167	2	HOSE CLIP	

Item	Part Number	Qty	Description Comments	Technical Specification
32	72438345	2	HOSE CLIP HEATING --> 258/16544	
	72438345	1	HOSE CLIP HEATING <-- 258/16545	
33	72378080	1	PRESSURE HOSE HEATING --> 258/16544 <> <>	
	72399926	1	LABEL	
	72379995	1	BLEEDER VALVE	
	72378080	1	PRESSURE HOSE	
	72379995	1	BLEEDER VALVE HEATING <-- 258/16545	
	72399926	1	LABEL HEATING <-- 258/16545	
34	72377530	2	RING HOSE NIPPLE HEATING --> 258/16544	FWN65910-A-DN2
35	72315809	2	BANJO BOLT HEATING	DIN 7643-4-5-A3L
36	72315086	4	SEALING WASHER HEATING	DIN 7603 A8X11,5-CU

FARMER 105 (258/10601-99999)  
137

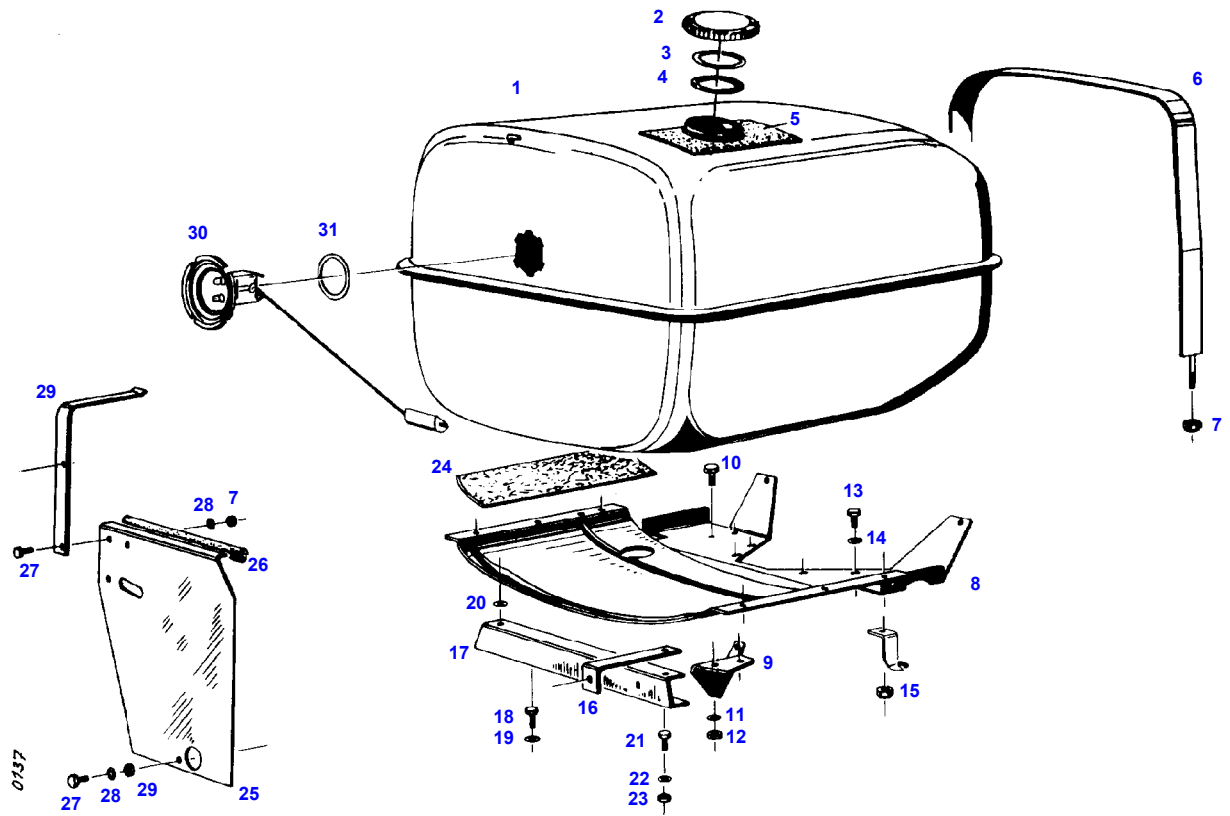

Item	Part Number	Qty	Description Comments	Technical Specification
			<-- 258/10601	
1	72359331	1	FUEL TANK --> 258/15579	
	72361712	1	FUEL TANK <-- 258/15580	
	72433112	1	STRAINER NOT ILLUSTRATED <-- 258/19183	60X100-MS
2	72380143	1	FUEL CAP ><2-4	M.BELUEF
	72348297	1	FUEL CAP LOCKABLE ><2-4	
3	72330726	1	SEAL 0,5 MM	
4	72330725	1	SEAL 2,5 MM	
5	72399898	1	RUBBER PLATE	
6	72359332	2	BAND CLAMP	
7	72313266	4	NUT	DIN 934 M6-8A3L
8	72399899	1	TANK TRAY	
	72450974	1	EDGE TRIM 1X 950 MM CUT TO LENGTH NOT ILLUSTRATED	L=1000 FWN 63040 D23
9	72404240	1	MOUNTING ANGLE SHUTTLE TRANSMISSION	
10	72315642	2	HEXAGONAL HEAD BOLT SHUTTLE TRANSMISSION	DIN 933 M8 X 16-8.8A3L
11	72315053	2	SPLIT WASHER SHUTTLE TRANSMISSION	FWN 65208-8-A3L
12	72313268	2	NUT SHUTTLE TRANSMISSION	DIN 934 M8-8A3L
13	72315675	4	HEXAGONAL HEAD BOLT	DIN 933 M10X16-8.8A3L
14	72315054	4	SPLIT WASHER	FWN 65208-10-A3L
15	72313318	4	NUT	DIN6925-M6-8-A3L
16	72404238	1	ANGLE	
17	72404241	1	ANGLE IRON NOT NECESSARY WITH FRONT LOADER	
18	72315642	2	HEXAGONAL HEAD BOLT NOT NECESSARY WITH FRONT LOADER	DIN 933 M8 X 16-8.8A3L
19	72315053	2	SPLIT WASHER NOT NECESSARY WITH FRONT LOADER	FWN 65208-8-A3L
20	72311788	2	DISC	DIN 125-8,4-ST.A3L
21	72315650	2	HEXAGONAL HEAD BOLT	DIN 933 M8 X 20-8.8A3L
22	72315053	2	SPLIT WASHER	FWN 65208-8-A3L
23	72313268	2	NUT NOT NECESSARY WITH FRONT LOADER	DIN 934 M8-8A3L
24	72399900	2	FELT STRIP	
25	72404237	1	BARRIER WALL	
26	72450971	1	SHAPED CORD 1X 230 MM CUT TO LENGTH	L=1000 FWN 63040 C02
27	72315629	2	HEXAGONAL HEAD BOLT --> 258/15806	DIN 933 M6 X 12-8.8A3L
	72315629	1	HEXAGONAL HEAD BOLT <-- 258/15807	DIN 933 M6 X 12-8.8A3L
	72315626	1	HEXAGONAL HEAD BOLT <-- 258/15807	DIN 933-M6 X 16-8.8-A3L
28	72315052	2	SPLIT WASHER	FWN 65208-6-A3L
29	72404239	1	GUSSET PLATE	
30	72613427	1	FUEL LEVEL SENSOR ><31	
31	72315169	1	SEALING WASHER	

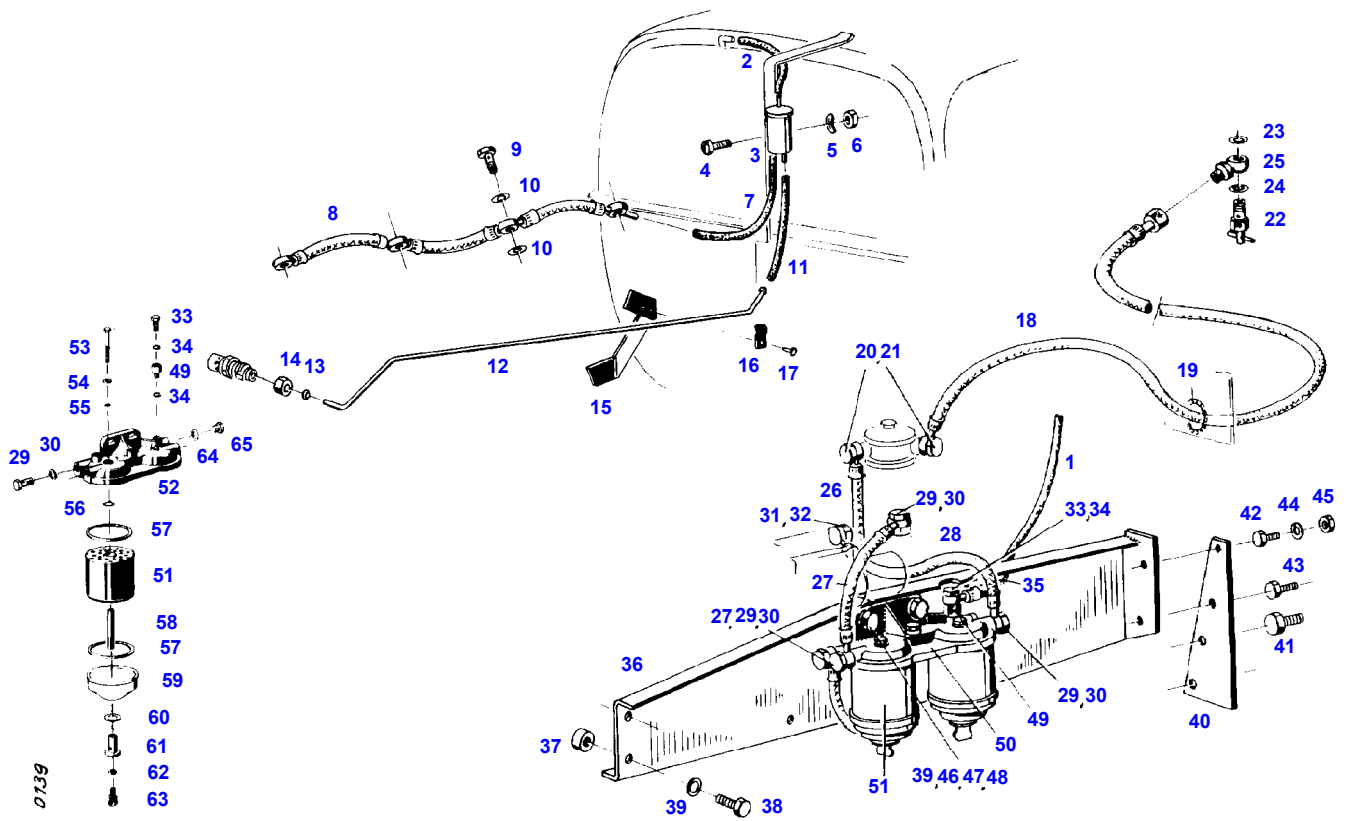

0139



Item	Part Number	Qty	Description Comments	Technical Specification
			<-- 258/10601 --> 258/14808	
1	72361699	1	FUEL LINE	
	72438345	1	HOSE CLIP	
2	72450301	1	PRESSURE HOSE 210 MM CUT TO LENGTH --> 258/13781	L=1000
	72450301	1	PRESSURE HOSE 420 MM CUT TO LENGTH <-- 258/13782	L=1000
	72438345	1	HOSE CLIP	
3	72380142	1	AUXILIARY FUEL TANK --> 258/13781	
			NOT USED <-- 258/13782	
4	72373594	1	SOCKET HEAD BOLT --> 258/13781	DIN 84 M4X12-4.8-A3L
	72315791	1	SCREW --> 258/13781	DIN 7981 ST4,8X19-C-H-A3L
			NOT USED <-- 258/13782	
5	72315050	1	SPLIT WASHER --> 258/13781	FWN 65208-4-A3L
	72311785	1	DISC --> 258/13781	DIN 125-5,3-ST.A3L
			NOT USED <-- 258/13782	
6	72313263	1	NUT --> 258/13781	DIN 934 M4-8A3L
			NOT USED <-- 258/13782	
7	72450301	1	PRESSURE HOSE 250 MM CUT TO LENGTH --> 258/13781	L=1000
	72450301	1	PRESSURE HOSE 420 MM CUT TO LENGTH <-- 258/13782 --> 258/14808	L=1000
			NOT USED <-- 258/13782	
8	72339360	1	LEAKAGE OIL LINE	
	72438345	1	HOSE CLIP NOT ILLUSTRATED	
9	72315809	4	BANJO BOLT	DIN 7643-4-5-A3L
10	72315086	8	SEALING WASHER	DIN 7603 A8X11,5-CU
11	72450301	1	PRESSURE HOSE 140 MM CUT TO LENGTH --> 258/13781	L=1000
	72438345	1	HOSE CLIP NOT USED --> 258/13781 <-- 258/13782	
12	72404244	1	TUBING --> 258/13781	
			NOT USED <-- 258/13782	

## FUEL LINES

Item	Part Number	Qty	Description Comments	Technical Specification
13	72380003	1	DOUBLE V-RING --> 258/13781  NOT USED <-- 258/13782	
14	72339362	1	CONNECTING NUT --> 258/13781  NOT USED <-- 258/13782	
15	72404245	1	RETAINING BRACKET --> 258/13781  NOT USED <-- 258/13782	
16	72373444	1	FASTENING COLLAR --> 258/13781  NOT USED <-- 258/13782	DIN 72571-1X5-ST.A3L
17	72315789	1	SCREW --> 258/13781  NOT USED <-- 258/13782	DIN 7981 ST4,8X9,5-C-H-A3
18	72361695	1	FUEL LINE	
19	72450577	1	EDGE PROTECTION 1X 91 MM CUT TO LENGTH	
20	72315808	2	BANJO BOLT	DIN 7643-10-3-A3L
21	72315094	4	SEALING WASHER	DIN 7603 A14X18-CU
22	72380159	1	FUEL SHUT-OFF VALVE	
23	72315093	1	SEALING WASHER	DIN 7603 A12X18-CU
24	72315094	1	SEALING WASHER	DIN 7603 A14X18-CU
25	72316302	1	NOZZLE	LL10 DIN7641/12.69 A3L
26	72361696	1	FUEL LINE	
27	72361697	1	FUEL LINE	
28	72361698	1	FUEL LINE	
29	72315807	4	BANJO BOLT	DIN 7643-8-3-A3L
30	72315093	8	SEALING WASHER	DIN 7603 A12X18-CU
31	72339379	1	BANJO BOLT	
32	72315086	2	SEALING WASHER	DIN 7603 A8X11,5-CU
33	72339376	1	BANJO BOLT	
34	72315088	3	SEALING WASHER	DIN 7603 A10X13,5-CU
35	72380013	1	EDGE PROTECTION	FLEXIF.
36	72404242	1	FILTER RETAINER	
37	72399913	2	HOLDER	
38	72315689	2	HEXAGONAL HEAD BOLT	DIN 933 M10X35-8.8A3L
39	72315054	4	SPLIT WASHER	FWN 65208-10-A3L
40	72404243	1	RETAINING SHEET METAL	
41	72374490	2	HEXAGONAL HEAD BOLT	DIN 933 M14X20-8.8
42	72315642	1	HEXAGONAL HEAD BOLT --> 258/13781	DIN 933 M8 X 16-8.8A3L
	72315650	1	HEXAGONAL HEAD BOLT <-- 258/13782	DIN 933 M8 X 20-8.8A3L
43	72315650	1	HEXAGONAL HEAD BOLT	DIN 933 M8 X 20-8.8A3L
44	72315053	2	SPLIT WASHER	FWN 65208-8-A3L
45	72313268	2	NUT	DIN 934 M8-8A3L
46	72315689	2	HEXAGONAL HEAD BOLT	DIN 933 M10X35-8.8A3L
47	72372811	2	NUT	DIN 934 M10-10A3L
48	72311789	2	DISC	DIN 125-10,5-ST.A3L
49	72339378	1	BLEED AND DRAIN VALVE	
50	72339361	1	DUAL FUEL FILTER ><51-65 <>	
	72339376	1	BANJO BOLT	

## FUEL LINES

Item	Part Number	Qty	Description Comments	Technical Specification
	72315088	1	SEALING WASHER	DIN 7603 A10X13,5-CU
	72315093	6	SEALING WASHER	DIN 7603 A12X18-CU
	72315807	3	BANJO BOLT	DIN 7643-8-3-A3L
	72339378	1	BLEED AND DRAIN VALVE	
51	72339363	2	FILTER BOX	
52	72339364	1	COVER	
53	72339365	2	CENTER SCREW	
54	72339366	2	SEALING WASHER	
55	72339430	2	PERMANENT REINFORCEMENT	
56	72376423	2	O-RING	14X3-NBR 70 FWN56402
57	72339369	4	SEALING WASHER	
58	72339380	2	ROUND NUT	
59	72380168	2	INSPECTION GLASS	
60	72339372	2	O-RING	
61	72339380	2	ROUND NUT	
62	72339374	2	SEALING WASHER	
63	72339375	2	WING SCREW	
64	72315093	1	SEALING WASHER	DIN 7603 A12X18-CU
65	72339377	1	SCREW	

FARMER 105 (258/10601-99999)  
140

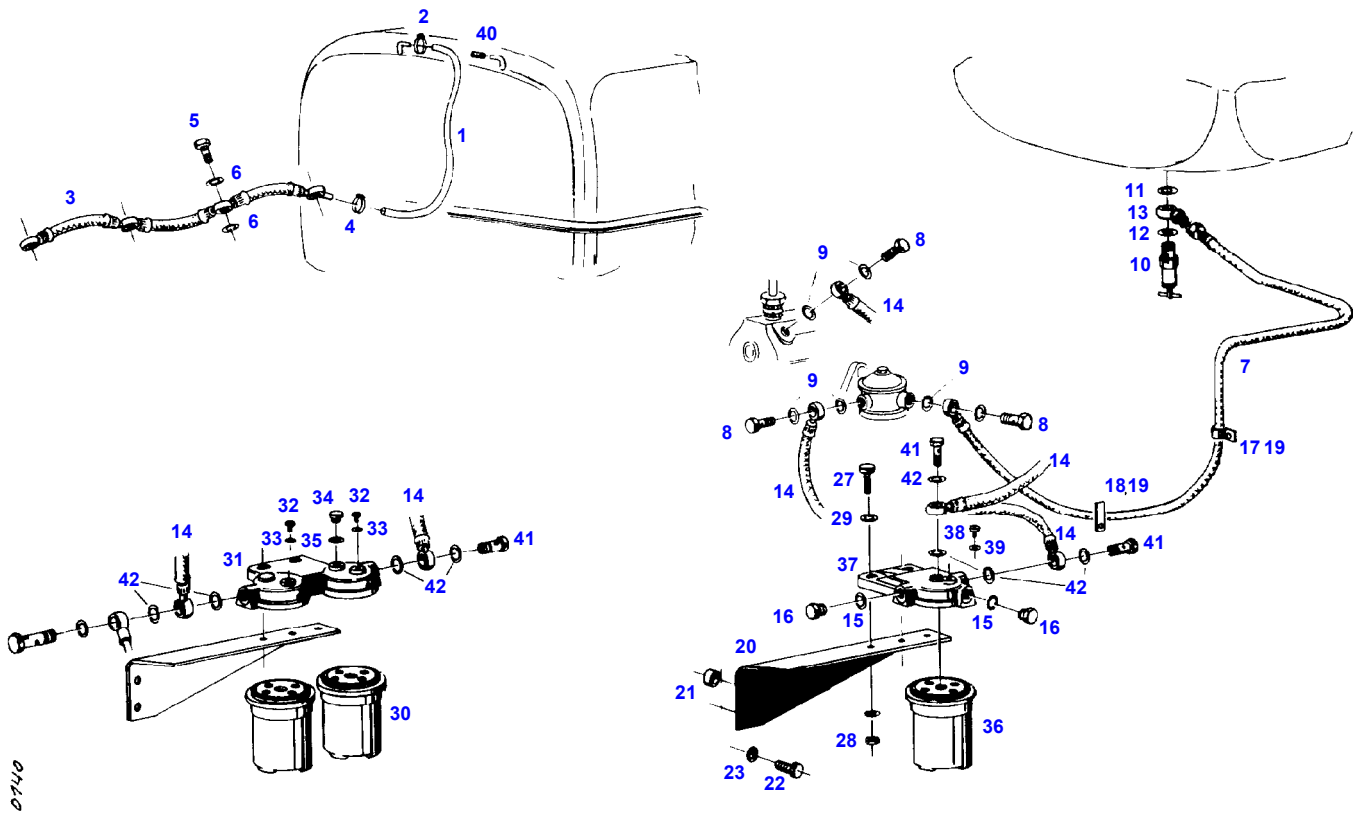

## FUEL LINES

Item	Part Number	Qty	Description Comments	Technical Specification
			<-- 258/14809	
1	72450301	1	PRESSURE HOSE 420 MM CUT TO LENGTH	L=1000
2	72438345	1	HOSE CLIP	
3	72339360	1	LEAKAGE OIL LINE	
4	72438345	1	HOSE CLIP	
5	72315809	4	BANJO BOLT	DIN 7643-4-5-A3L
6	72315086	8	SEALING WASHER	DIN 7603 A8X11,5-CU
7	72361710	1	FUEL LINE	
8	72315808	3	BANJO BOLT	DIN 7643-10-3-A3L
9	72315094	6	SEALING WASHER	DIN 7603 A14X18-CU
10	72380159	1	FUEL SHUT-OFF VALVE	
11	72315093	1	SEALING WASHER	DIN 7603 A12X18-CU
12	72315094	1	SEALING WASHER	DIN 7603 A14X18-CU
13	72316302	1	NOZZLE	LL10 DIN7641/12.69 A3L
14	72365147	2	FUEL LINE --> 258/15806	
	72365147	1	FUEL LINE <-- 258/15807 FUEL PUMP / FUEL FILTER	
	72356760	1	FUEL LINE <-- 258/15807 INJECTION PUMP / FUEL FILTER	
15	72315094	2	SEALING WASHER	DIN 7603 A14X18-CU
16	72315799	2	PLUG	DIN 7604 AM14X1,5-A3L
17	72373452	1	FASTENING COLLAR	DIN 72571-1X15-ST A3L
18	72399911	1	SHEET METAL	
19	72372699	2	SLOTTED PIN	DIN 1476-4X6-ST.A3L
20	72391202	1	MOUNTING ANGLE --> 258/15806	
	72399912	1	RETAINER <-- 258/15807	
21	72399913	2	HOLDER	
22	72315689	2	HEXAGONAL HEAD BOLT	DIN 933 M10X35-8.8A3L
23	72315054	4	SPLIT WASHER	FWN 65208-10-A3L
27	72315689	2	HEXAGONAL HEAD BOLT	DIN 933 M10X35-8.8A3L
28	72372811	2	NUT	DIN 934 M10-10A3L
29	72311789	2	DISC	DIN 125-10,5-ST.A3L
30			NO LONGER AVAILABLE SEE SINGLE PARTS ><30-35 TROPICAL VERSION	
	72326245	2	FILTER BOX	
31	72326249	1	FILTER LID	
32	72323290	2	BLEED SCREW	
33	72315084	2	SEALING WASHER	DIN 7603 A6X10-CU
34	72326250	1	SCREW	
35	72315094	1	SEALING WASHER	DIN 7603 A14X18-CU
36	72326244	1	FILTER ><36-39 <-- F181.200.060.010	
	72326245	1	FILTER BOX	
37	72326247	1	FILTER LID	
38	72323290	1	BLEED SCREW	
39	72315084	1	SEALING WASHER	DIN 7603 A6X10-CU
40			NO LONGER AVAILABLE	
41	72315808	2	BANJO BOLT	DIN 7643-10-3-A3L
42	72315094	5	SEALING WASHER	DIN 7603 A14X18-CU

FARMER 105 (258/10601-99999)  
146

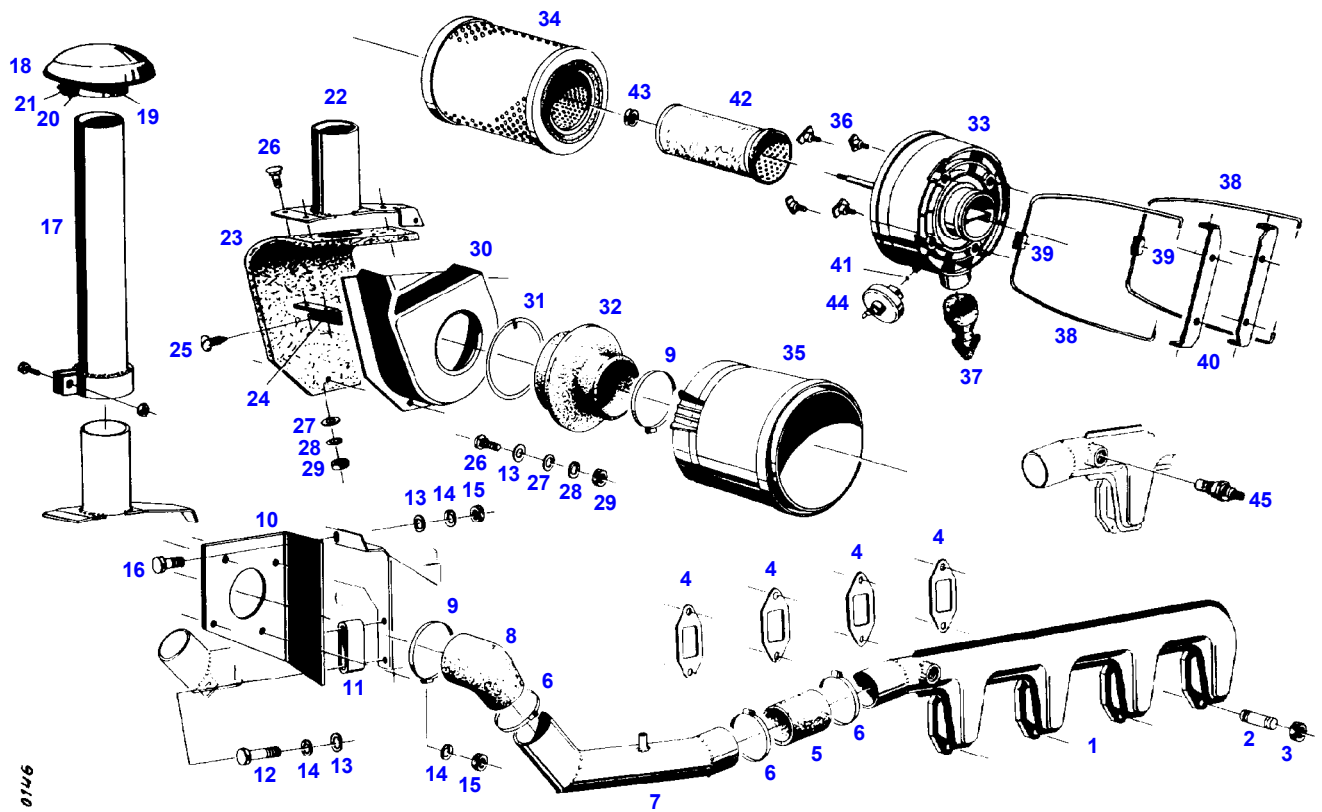

Item	Part Number	Qty	Description Comments	Technical Specification
			<-- 258/10601	
1	72339381	1	INTAKE MANIFOLD	
2	72373922	8	STUD BOLT	DIN 835-M10X25-8.8
3	72313272	8	NUT	DIN 934 M10-8A3L
4	72332145	4	MOLDED SEAL	
5	72399914	1	REDUCER	
6	72311170	3	HOSE CLIP	
7	72361700	1	INTAKE MANIFOLD	
	72361700	1	INTAKE MANIFOLD WITH AIR BRAKING SYSTEM <>	
	72404253	1	CONNECTION PIPE	
8	72404248	1	INTAKE BEND	
9	72373528	2	HOSE CLIP	
10	72404246	1	RETAINING BRACKET	
11			NO LONGER AVAILABLE	
12	72374158	2	HEXAGONAL HEAD BOLT	DIN 931 M8X45-8.8
13	72311788	5	DISC	DIN 125-8,4-ST.A3L
14	72315053	7	SPLIT WASHER	FWN 65208-8-A3L
15	72313268	5	NUT	DIN 934 M8-8A3L
16	72315650	1	HEXAGONAL HEAD BOLT	DIN 933 M8 X 20-8.8A3L
17			NO LONGER AVAILABLE	
18	72330730	1	RAIN CAP ><19-21	
19	72328616	1	PIPE CLAMP	
20	72320202	1	SPECIAL SCREW	
21	72372783	1	SQUARE NUT	DIN 557 M6-5 A3L
22	72361701	1	BRACKET	
23	72450563	1	SEALING STRIP 1X 900MM CUT TO LENGTH	15X30 L=2000 OWA W77
24	72404249	1	ANGLE	
25	72315820	1	SCREW	DIN7976-ST6,3X13-C-A3L
	72315821	1	SCREW	DIN7976-ST6,3X19-C-A3L
26	72373806	4	TRUSS HEAD SCREW	DIN 603 M6X16-A3L
	72311824	1	DISC	DIN9021-8,4-140HV-A3L
27	72311787	3	DISC	DIN 125-6,4-ST.A3L
28	72315052	4	SPLIT WASHER	FWN 65208-6-A3L
29	72313266	4	NUT	DIN 934 M6-8A3L
30	72404247	1	AIR INTAKE BOX	
31	72404251	1	STIFFENING RING	
32	72404250	1	BELLOWS	
33	72349621	1	AIR FILTER ><34-42	
34	72339382	1	MICRO-TOP CARTRIDGE	
35	72339384	1	ENGINE HOOD --> 258/11040	
	72339385	1	ENGINE HOOD <-- 258/11041	
36	72328310	4	SCREW	
37	72326122	1	DUST DISCHARGE VALVE	
38	72328222	2	HOLDER ><39	
39	72328313	2	TENSIONING DEVICE	
40	72328309	2	ANGLE	
41	72339386	1	FELT WASHER	
42	72380180	1	SAFETY CARTRIDGE <-- 258/11041	
43	72313268	1	NUT <-- 258/11041	DIN 934 M8-8A3L
44	72316876	1	MAINTENANCE SWITCH <>	

Item	Part Number	Qty	Description Comments	Technical Specification
	72379171	0	WIRE	B1 DIN72551/6.51 SCHWARZ
	72380356	1	CABLE LUG	
	72314686	1	PLUG IN SLEEVE	
45			SEE COLD STARTING AID NO LONGER AVAILABLE --> 258/13781	
	72399916	1	SCREW NOT ILLUSTRATED <-- 258/14809	
	72315101	1	SEALING WASHER NOT ILLUSTRATED <-- 258/14809	DIN 7603 A22X27-CU



FARMER 105 (258/10601-99999)  
628

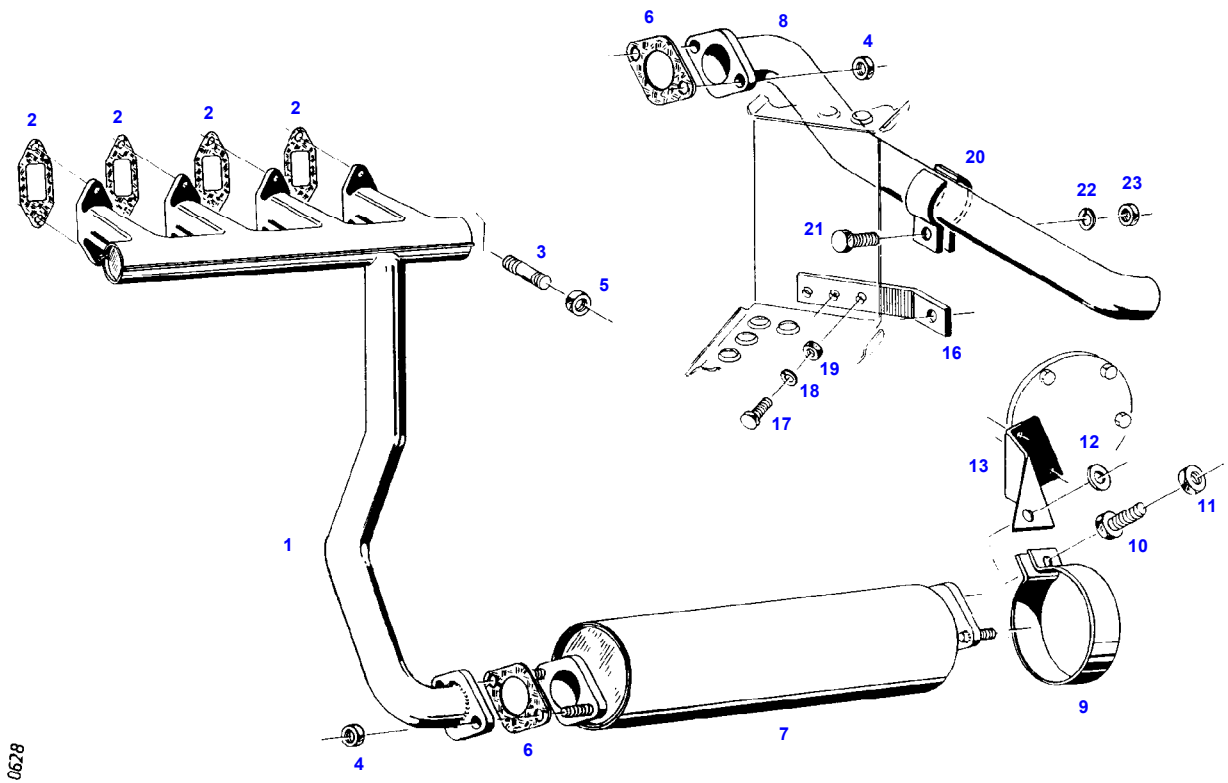

0628

Item	Part Number	Qty	Description Comments	Technical Specification
			<b>105 S</b> <b>&lt;-- 258/10601</b>	
1	72404255	1	EXHAUST COLLECTING PIPE --> 258/14805 <> <>	
	72360671	1	EXHAUST PIPE	
	72313776	2	STUD BOLT	DIN 939 M10X25-8.8
	72313777	8	STUD BOLT	DIN 939 M10X35-8.8
	72313273	2	NUT	DIN 934 M10-MS
	72376173	1	SEAL	DIN71511-56X82X1,5-ST AFM5M.E.
	72360671	1	EXHAUST PIPE <-- 258/14806	
	72404255	1	EXHAUST COLLECTING PIPE NOT ILLUSTRATED <-- 258/14806	
	72376173	1	SEAL NOT ILLUSTRATED <-- 258/14806	DIN71511-56X82X1,5-ST AFM5M.E.
	72313776	2	STUD BOLT NOT ILLUSTRATED <-- 258/14806	DIN 939 M10X25-8.8
	72373015	2	NUT NOT ILLUSTRATED <-- 258/14806	DIN70615-M10-8-A3B
2	72332145	4	MOLDED SEAL	
3	72313776	8	STUD BOLT --> 258/13781	DIN 939 M10X25-8.8
	72313777	8	STUD BOLT <-- 258/13782	DIN 939 M10X35-8.8
4	72373015	4	NUT --> 258/14805	DIN70615-M10-8-A3B
	72373015	6	NUT <-- 258/14806	DIN70615-M10-8-A3B
5	72373015	8	NUT	DIN70615-M10-8-A3B
6	72376173	2	SEAL	DIN71511-56X82X1,5-ST AFM5M.E.
7	72353113	1	EXHAUST BOX	
8	72360862	1	EXHAUST PIPE	
9	72402044	1	CLAMP	
10	72315709	1	HEXAGONAL HEAD BOLT	DIN 933 M12X30-8.8A3L
11	72313277	1	NUT	DIN 934-M12-10-A3L
12	72311791	1	DISC	DIN 125-13-ST.A3L
13	72402042	1	RETAINING BRACKET	
	72315651	2	HEXAGONAL HEAD BOLT NOT ILLUSTRATED	DIN 933 M8X22-8.8A3L
16	72402043	1	ANGLE	
17	72315630	2	HEXAGONAL HEAD BOLT	DIN 933 M6X18-8.8A3L
18	72315052	2	SPLIT WASHER	FWN 65208-6-A3L
19	72313266	2	NUT	DIN 934 M6-8A3L
20	72390121	2	CLAMP	
21	72315685	1	HEXAGONAL HEAD BOLT	DIN 933 M10X30-8.8A3L
22	72315054	1	SPLIT WASHER	FWN 65208-10-A3L
23	72372811	1	NUT	DIN 934 M10-10A3L

FARMER 105 (258/10601-99999)  
627

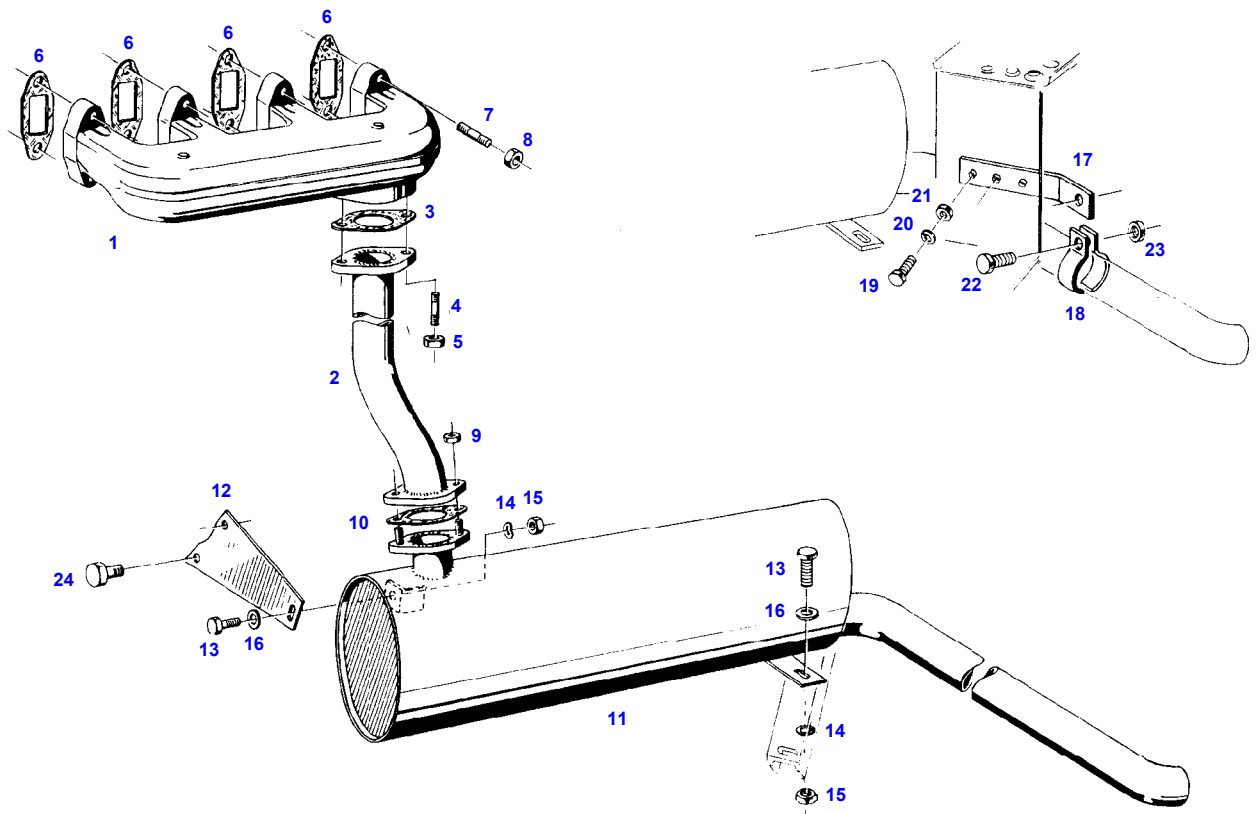

0627

Item	Part Number	Qty	Description Comments	Technical Specification
			<b>EXPORT SWITZERLAND 105 S</b>	
1	72404255	1	EXHAUST COLLECTING PIPE	
2	72361705	1	EXHAUST PIPE	
3	72376173	1	SEAL	DIN71511-56X82X1,5-ST AFM5M.E.
4	72313776	2	STUD BOLT	DIN 939 M10X25-8.8
5	72373015	2	NUT	DIN70615-M10-8-A3B
6	72332145	4	MOLDED SEAL	
7	72313777	8	STUD BOLT	DIN 939 M10X35-8.8
8	72373015	8	NUT	DIN70615-M10-8-A3B
9	72373015	2	NUT	DIN70615-M10-8-A3B
10	72376173	1	SEAL	DIN71511-56X82X1,5-ST AFM5M.E.
11	72361704	1	EXHAUST BOX	
12	72404254	1	RETAINING SHEET METAL	
13	72315646	2	HEXAGONAL HEAD BOLT	DIN 933 M8X18-8.8A3L
14	72315053	2	SPLIT WASHER	FWN 65208-8-A3L
15	72313268	2	NUT	DIN 934 M8-8A3L
16	72311788	2	DISC	DIN 125-8,4-ST.A3L
17	72402043	1	ANGLE	
18	72390121	2	CLAMP	
19	72315630	2	HEXAGONAL HEAD BOLT	DIN 933 M6X18-8.8A3L
20	72315052	2	SPLIT WASHER	FWN 65208-6-A3L
21	72313266	2	NUT	DIN 934 M6-8A3L
22	72315685	1	HEXAGONAL HEAD BOLT	DIN 933 M10X30-8.8A3L
23	72313272	1	NUT	DIN 934 M10-8A3L
24	72374490	2	HEXAGONAL HEAD BOLT	DIN 933 M14X20-8.8

FARMER 105 (258/10601-99999)  
148

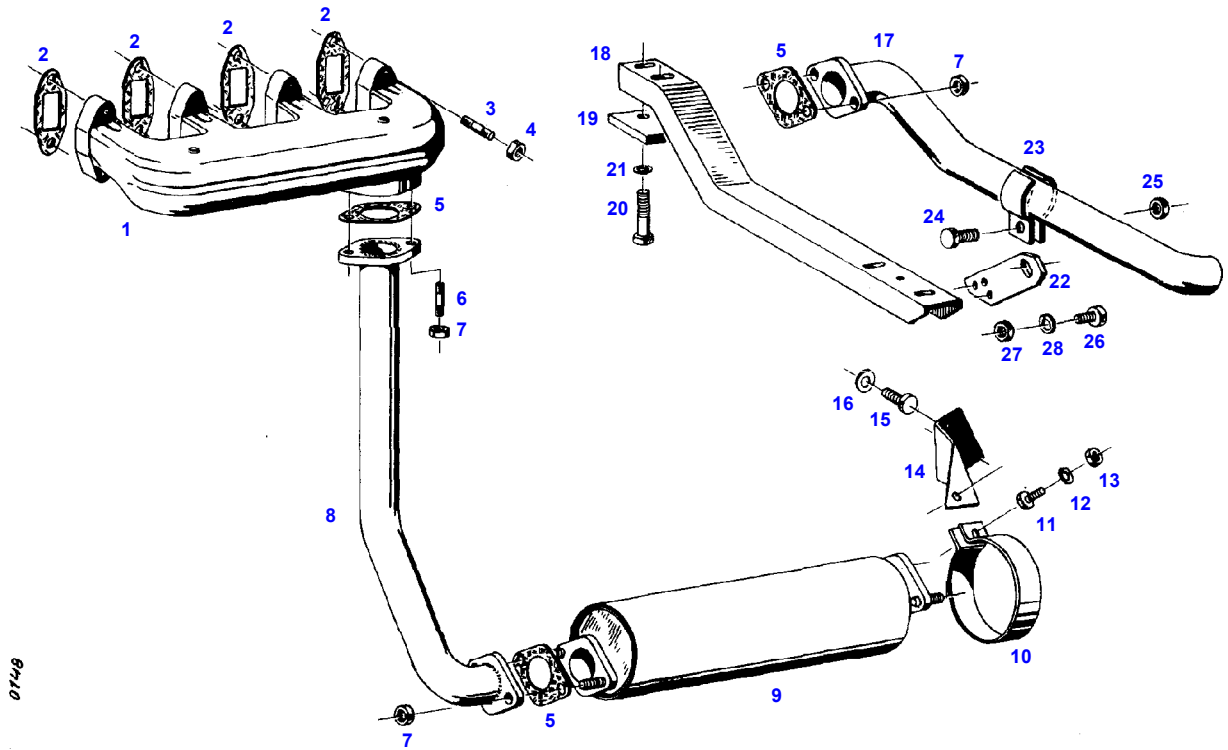

0148

Item	Part Number	Qty	Description Comments	Technical Specification
			<b>105 LS</b> <b>--&gt; 258/20000</b>	
1	72404255	1	EXHAUST COLLECTING PIPE	
2	72332145	4	MOLDED SEAL	
3	72313777	8	STUD BOLT	DIN 939 M10X35-8.8
4	72373015	8	NUT	DIN70615-M10-8-A3B
5	72376173	3	SEAL	DIN71511-56X82X1,5-ST AFM5M.E.
6	72313776	2	STUD BOLT	DIN 939 M10X25-8.8
7	72373015	6	NUT	DIN70615-M10-8-A3B
8	72360671	1	EXHAUST PIPE	
9	72353113	1	EXHAUST BOX	
10	72402044	1	CLAMP	
11	72315709	1	HEXAGONAL HEAD BOLT	DIN 933 M12X30-8.8A3L
12	72311791	1	DISC	DIN 125-13-ST.A3L
13	72313276	1	NUT	DIN 934 M12-8A3L
14	72402042	1	RETAINING BRACKET	
15	72315651	2	HEXAGONAL HEAD BOLT	DIN 933 M8X22-8.8A3L
16	72311824	1	DISC	DIN9021-8,4-140HV-A3L
17	72360862	1	EXHAUST PIPE	
18	72402048	1	RETAINER RAIL	
19	72389295	1	PLATE	
20	72374215	2	HEXAGONAL HEAD BOLT	DIN 931 M12X65-8.8
21	72315055	2	SPLIT WASHER	FWN 65208-12-A3L
22	72402049	1	PLATE LINK	
23	72390121	2	CLAMP	
24	72315685	1	HEXAGONAL HEAD BOLT	DIN 933 M10X30-8.8A3L
25	72313272	1	NUT	DIN 934 M10-8A3L
26	72315653	2	HEXAGONAL HEAD BOLT	DIN 933 M8 X 25-8.8A3L
27	72313268	2	NUT	DIN 934 M8-8A3L
28	72315053	2	SPLIT WASHER	FWN 65208-8-A3L

FARMER 105 (258/10601-99999)  
995

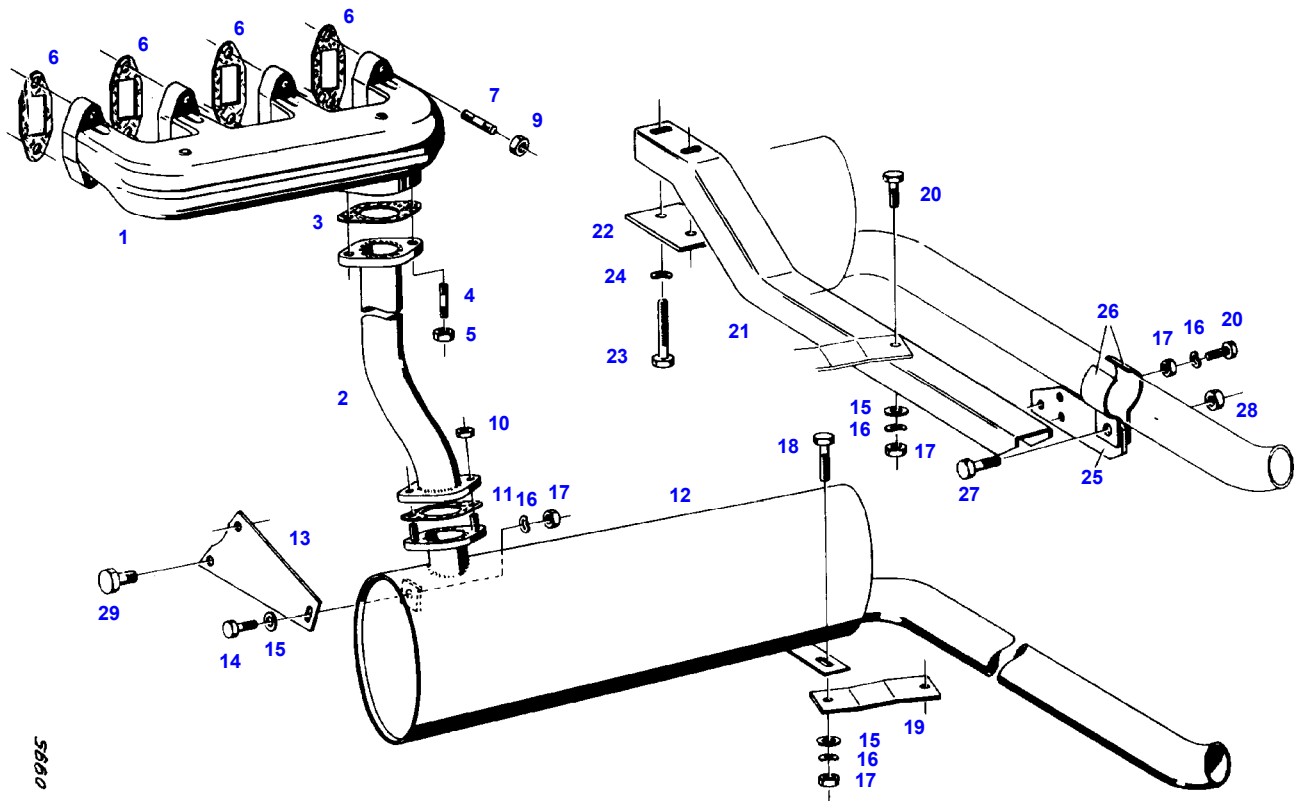

5880

Item	Part Number	Qty	Description Comments	Technical Specification
			<b>EXPORT SWITZERLAND 105 LS --&gt; 258/20000</b>	
1	72404255	1	EXHAUST COLLECTING PIPE	
2	72361705	1	EXHAUST PIPE	
3	72376173	1	SEAL	DIN71511-56X82X1,5-ST AFM5M.E.
4	72313776	2	STUD BOLT	DIN 939 M10X25-8.8
5	72373015	2	NUT	DIN70615-M10-8-A3B
6	72332145	4	MOLDED SEAL	
7	72313777	8	STUD BOLT	DIN 939 M10X35-8.8
9	72373015	8	NUT	DIN70615-M10-8-A3B
10	72373015	2	NUT	DIN70615-M10-8-A3B
11	72376173	1	SEAL	DIN71511-56X82X1,5-ST AFM5M.E.
12	72361704	1	EXHAUST BOX	
13	72404254	1	RETAINING SHEET METAL	
14	72315642	1	HEXAGONAL HEAD BOLT	DIN 933 M8 X 16-8.8A3L
15	72311788	3	DISC	DIN 125-8,4-ST.A3L
16	72315053	5	SPLIT WASHER	FWN 65208-8-A3L
17	72313268	5	NUT	DIN 934 M8-8A3L
18	72315650	1	HEXAGONAL HEAD BOLT	DIN 933 M8 X 20-8.8A3L
19	72404256	1	WEB	
20	72315653	3	HEXAGONAL HEAD BOLT	DIN 933 M8 X 25-8.8A3L
21	72402048	1	RETAINER RAIL	
22	72389295	1	PLATE	
23	72374215	2	HEXAGONAL HEAD BOLT	DIN 931 M12X65-8.8
24	72315055	2	SPLIT WASHER	FWN 65208-12-A3L
25	72402049	1	PLATE LINK	
26	72390121	2	CLAMP	
27	72315685	1	HEXAGONAL HEAD BOLT	DIN 933 M10X30-8.8A3L
28	72313272	1	NUT	DIN 934 M10-8A3L
29	72374490	2	HEXAGONAL HEAD BOLT	DIN 933 M14X20-8.8



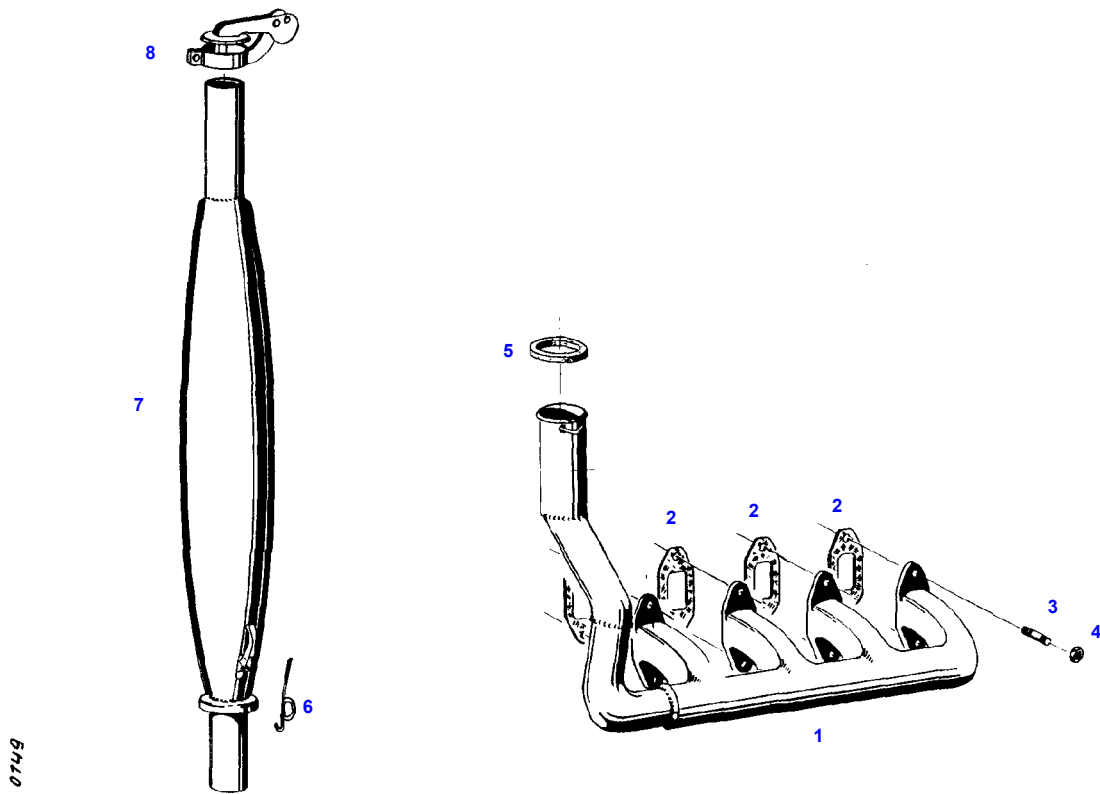

07110

Item	Part Number	Qty	Description Comments	Technical Specification
			<-- 258/10601	
1	72361706	1	EXHAUST COLLECTING PIPE --> 258/14809	
	72361714	1	EXHAUST COLLECTING PIPE <-- 258/14810	
	72361706	1	EXHAUST COLLECTING PIPE FOR FRONT POWER TAKE OFF WITH FRONT POWER LIFT <-- 258/20001	
2	72332145	4	MOLDED SEAL	
3	72313776	8	STUD BOLT	DIN 939 M10X25-8.8
4	72373015	8	NUT	DIN70615-M10-8-A3B
5	72389300	1	SEAL --> 258/14809	
	72389300	1	SEAL FOR FRONT POWER TAKE OFF WITH FRONT POWER LIFT <-- 258/20001	
6	72389301	2	THREADED HOOK --> 258/14809	
	72389301	2	THREADED HOOK FOR FRONT POWER TAKE OFF WITH FRONT POWER LIFT <-- 258/20001	
7	72353215	1	EXHAUST MUFFLER --> 258/14809	
	72359347	1	EXHAUST MUFFLER <-- 258/14810	
	72353215	1	EXHAUST MUFFLER FOR FRONT POWER TAKE OFF WITH FRONT POWER LIFT <-- 258/20001	
	72321360	1	CLAMPING FIXTURE NOT ILLUSTRATED	
8	72347590	1	EXHAUST WEATHER CAP	

FARMER 105 (258/10601-99999)  
150

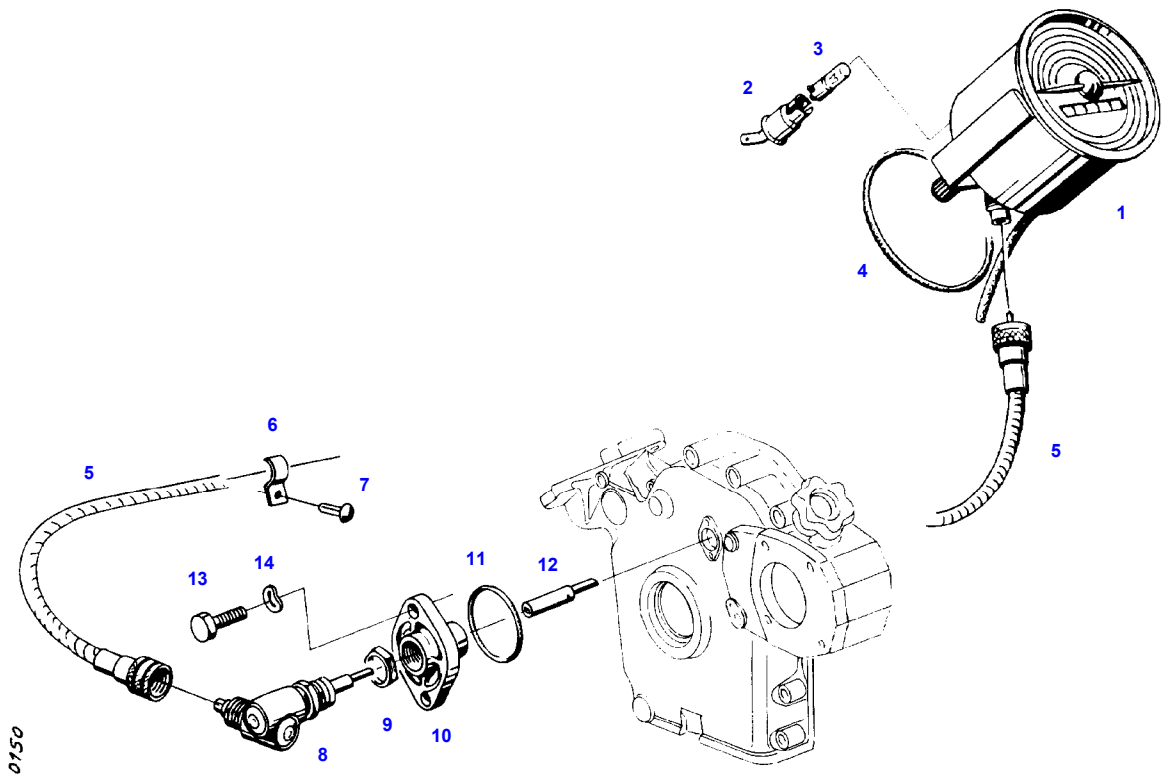

Item	Part Number	Qty	Description Comments	Technical Specification
			<-- 258/10601	
1	72379813	1	TRACTOMETER ><1-4 30 KM/H	100
	72379815	1	TRACTOMETER ><1-4 25 KM/H	100
	72353224	1	EARTH LEAD NOT ILLUSTRATED	
2	72379814	1	LAMP SOCKET	
3	72334852	1	FILAMENT BULB	
4	72376658	1	O-RING	100X3-NBR 70 FWN56402
5	72483813	1	DRIVE SHAFT --> 258/14536	
	72483829	1	DRIVE SHAFT <-- 258/14537	
6	72373448	1	FASTENING COLLAR --> 258/14536	DIN 72571-1X8-ST VZK
			NOT USED <-- 258/14537	
7	72372699	1	SLOTTED PIN --> 258/14536	DIN 1476-4X6-ST.A3L
			NOT USED <-- 258/14537	
	72316916	1	CABLE STRAP NOT ILLUSTRATED <-- 258/14537	FWN 66650 B175X4-SW
8	72334005	1	BEVEL GEAR SYSTEM	
9	72322566	1	NUT	
10	72335527	1	COVER	
11	72376544	1	O-RING	42,2X3-NBR 70 FWN56402
12	72327035	1	DRIVER	
13	72315650	2	HEXAGONAL HEAD BOLT	DIN 933 M8 X 20-8.8A3L
14	72317121	2	SPRING WASHER	DIN 137 B8-MECH.VZK

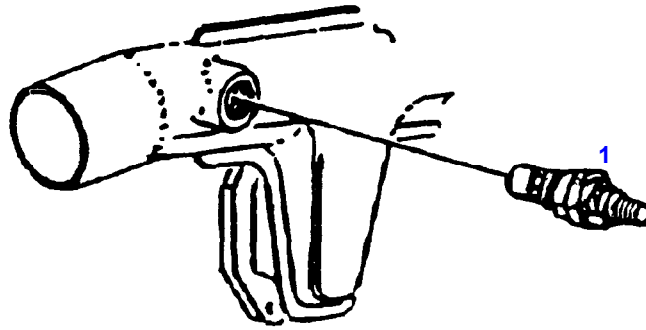

12100

---

Fendt

FARMER 105 (258/10601-99999)

F258001

COLD STARTING AID

Page01-0018

---

Item	Part Number	Qty	Description Comments
			<-- 258/10601 --> 258/13781
1	72339383	1	FLAME GLOW PLUG <-- 9071.406.110 1X REMACHINING MAY BE REQUIRED TO FIT

FARMER 105 (258/10601-99999)  
151

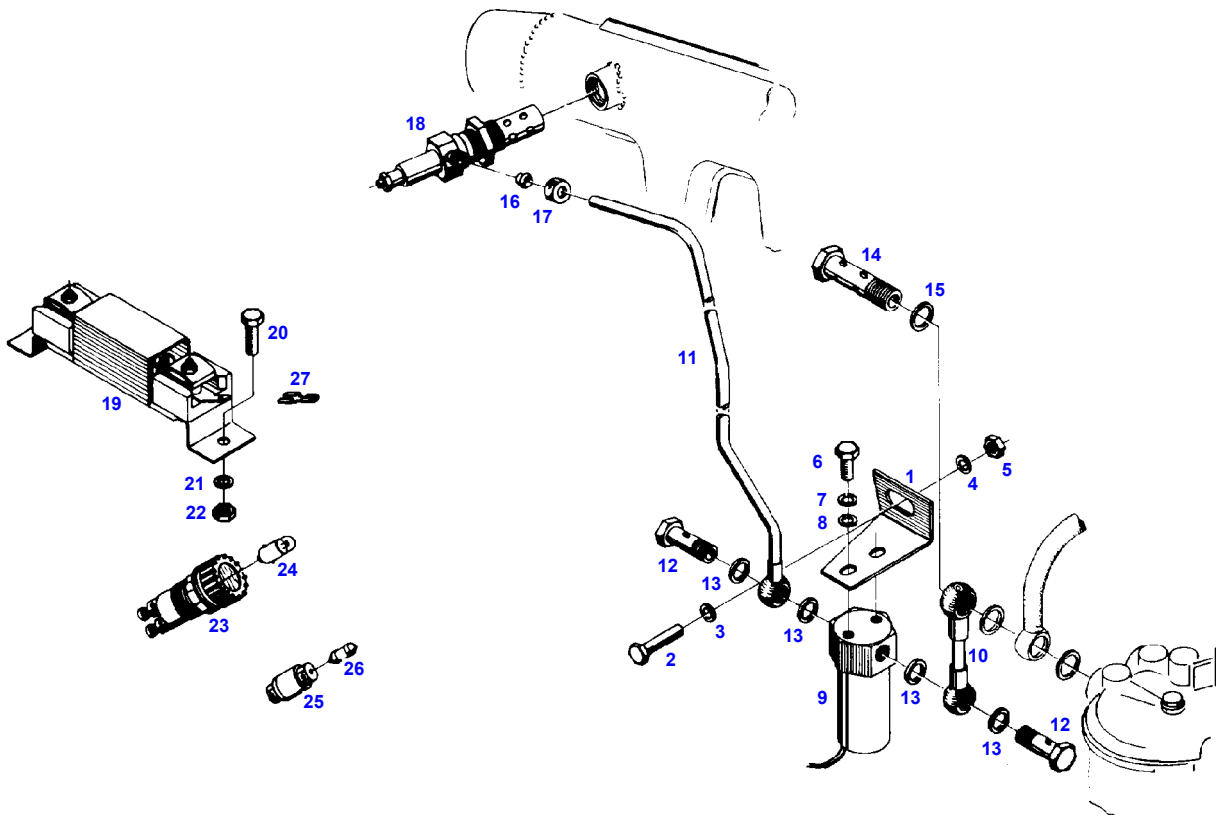

0151

Item	Part Number	Qty	Description Comments	Technical Specification
			<-- 258/13782 --> 258/14808	
1	72403257	1	MOUNTING ANGLE	
2	72315650	1	HEXAGONAL HEAD BOLT	DIN 933 M8 X 20-8.8A3L
3	72311788	2	DISC	DIN 125-8,4-ST.A3L
4	72315053	1	SPLIT WASHER	FWN 65208-8-A3L
5	72313268	1	NUT	DIN 934 M8-8A3L
6	72315629	2	HEXAGONAL HEAD BOLT	DIN 933 M6 X 12-8.8A3L
7	72315052	2	SPLIT WASHER	FWN 65208-6-A3L
8	72311787	2	DISC	DIN 125-6,4-ST.A3L
9	72317090	1	VALVE SOLENOID	
10	72339388	1	TUBING	
11	72361707	1	PIPE	
12	72315806	2	BANJO BOLT	DIN 7643-6-3-A3L
13	72315088	4	SEALING WASHER	DIN 7603 A10X13,5-CU
14	72310188	1	BANJO BOLT	
15	72315093	1	SEALING WASHER	DIN 7603 A12X18-CU
16	72377312	1	DOUBLE V-RING	DIN 3862-6-9SMNPB28K+G
17	72378005	1	CONNECTING NUT	DIN 3870 ALL6-9S20K A3L
18	72340899	1	FLAME GLOW PLUG	
19	72340900	1	BIMETAL RESISTOR	
20	72315626	2	HEXAGONAL HEAD BOLT	DIN 933-M6 X 16-8.8-A3L
21	72315052	2	SPLIT WASHER	FWN 65208-6-A3L
22	72313266	2	NUT	DIN 934 M6-8A3L
23	72321489	1	INDICATOR LIGHT	
24	72320730	1	FILAMENT BULB	
25	72380340	1	FUSE HOLDER	M.SI
			><26	
26	72338009	1	FUSE LINK	
27	72314686	2	PLUG IN SLEEVE	
	72316070	1	BUSHING INSULATOR	
	72333918	2	CABLE LUG	
	72327418	1	CABLE LUG	



FARMER 105 (258/10601-99999)  
152

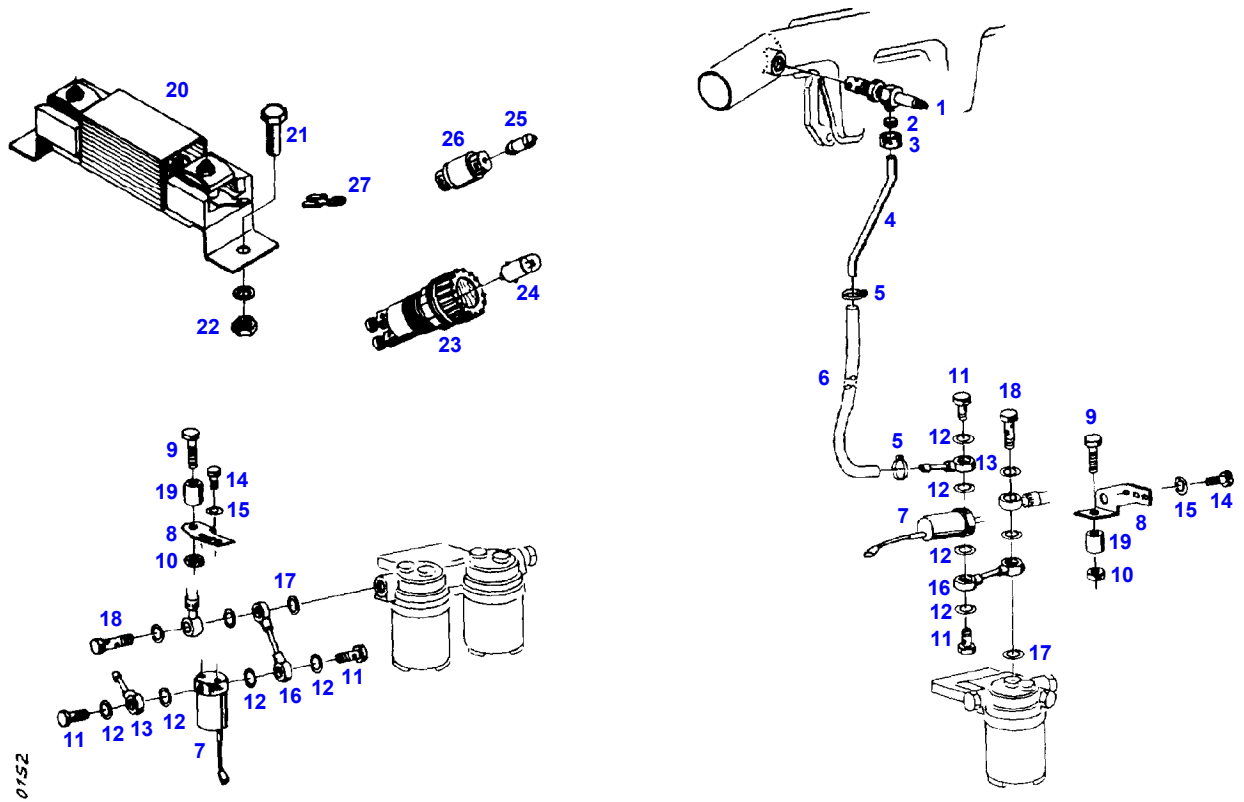

0152

Item	Part Number	Qty	Description Comments	Technical Specification
			<-- 258/14809	
1	72340899	1	FLAME GLOW PLUG	
2	72377312	1	DOUBLE V-RING	DIN 3862-6-9SMNPB28K+G
3	72378005	1	CONNECTING NUT	DIN 3870 ALL6-9S20K A3L
4	72399922	1	PIPE	
5	72438345	2	HOSE CLIP	
6	72450301	1	PRESSURE HOSE 500 MM CUT TO LENGTH	L=1000
7	72317090	1	VALVE SOLENOID	
8	72399921	1	ANGLE	
9	72315691	1	HEXAGONAL HEAD BOLT	DIN 933 M10X40-8.8A3L
10	72313272	1	NUT	DIN 934 M10-8A3L
11	72315806	2	BANJO BOLT	DIN 7643-6-3-A3L
12	72315088	4	SEALING WASHER	DIN 7603 A10X13,5-CU
13	72377528	1	RING HOSE NIPPLE	FWN65910-A-DN4
14	72315629	2	HEXAGONAL HEAD BOLT	DIN 933 M6 X 12-8.8A3L
15	72315052	4	SPLIT WASHER	FWN 65208-6-A3L
16	72377995	1	TUBING	FWN 65954 A4X50
17	72315094	1	SEALING WASHER	DIN 7603 A14X18-CU
18	72310187	1	DOUBLE BOLT	
19	72389510	1	PIPE	
20	72340900	1	BIMETAL RESISTOR	
21	72315626	2	HEXAGONAL HEAD BOLT	DIN 933-M6 X 16-8.8-A3L
22	72313266	2	NUT	DIN 934 M6-8A3L
23	72321489	1	INDICATOR LIGHT	
24	72320730	1	FILAMENT BULB	
25	72338009	1	FUSE LINK	
26	72380340	1	FUSE HOLDER	M.SI
27	72314686	2	PLUG IN SLEEVE	
30	72333918	2	CABLE LUG NOT ILLUSTRATED	
31	72327418	1	CABLE LUG NOT ILLUSTRATED	
32	72316070	1	BUSHING INSULATOR NOT ILLUSTRATED	

FARMER 105 (258/10601-99999)  
31201

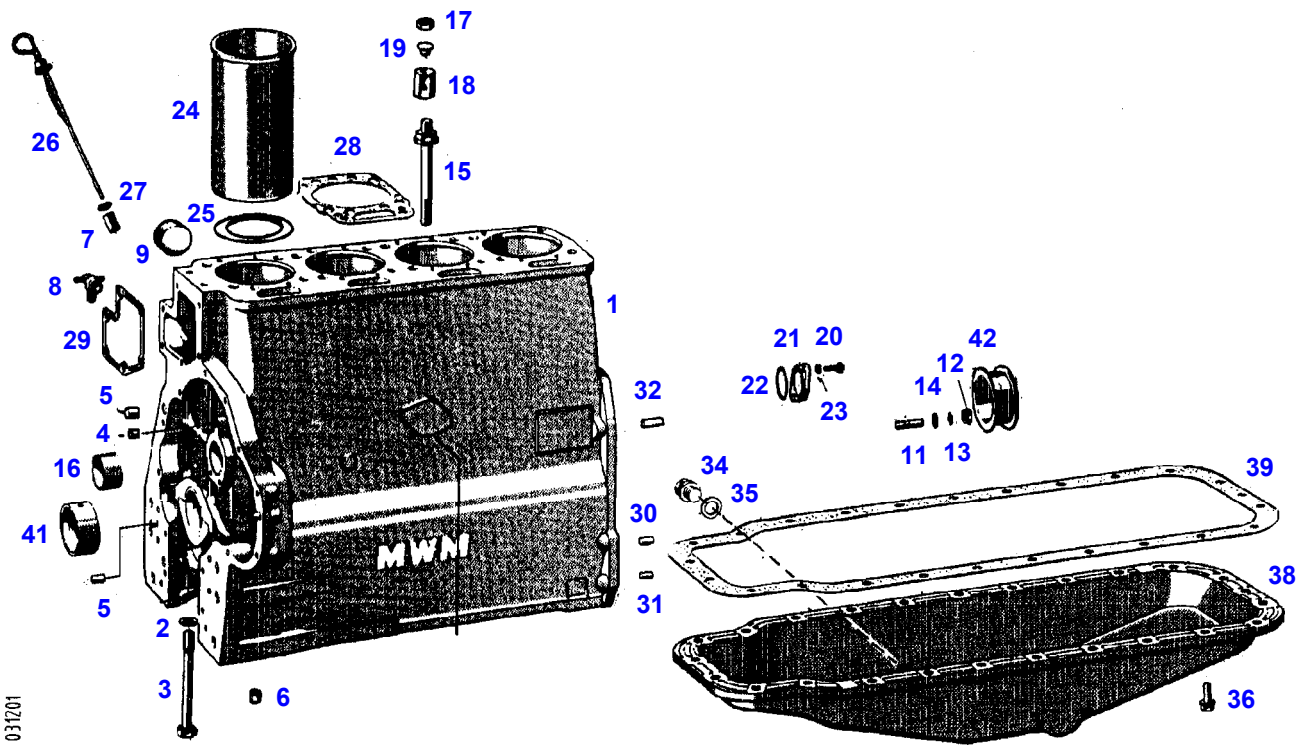

Item	Part Number	Qty	Description Comments	Technical Specification
			<-- 258/10601	
1	72339389	1	CRANKCASE ><1-11,24,31 --> 258/14808	
	72329106	1	CRANKCASE ><1-6,8,9,31 <-- 258/20001 --> 258/20300	
	72337045	1	CRANKCASE ><1-11,15,18,19,31 <-- 258/14809 --> 258/20000	
	72337045	1	CRANKCASE ><1-11,24,31 <-- 258/20301	
	72376161	1	SEAL NOT ILLUSTRATED --> 258/14808	DIN 71511-30-COL
	72313770	2	STUD BOLT NOT ILLUSTRATED --> 258/14808	FWN64891-M8X20-8.8
	72315053	2	SPLIT WASHER NOT ILLUSTRATED --> 258/14808	FWN 65208-8-A3L
	72313268	2	NUT NOT ILLUSTRATED --> 258/14808	DIN 934 M8-8A3L
	72331313	1	FLANGE NOT ILLUSTRATED --> 258/14808	
2	72324592	26	DISC	
3	72327081	10	HEXAGONAL HEAD BOLT	
4	72327772	7	PLUG F10	
5	72327773	3	PLUG F14	
6	72327068	2	PLUG F16	
	72315644	1	HEXAGONAL HEAD BOLT NOT ILLUSTRATED <-- 258/20001	DIN 933 M8X10-8.8A3L
	72315087	1	SEALING WASHER NOT ILLUSTRATED <-- 258/20001	DIN 7603 A8X14-CU
7	72326139	1	PIPE PIECE 32 MM ENG.NO. --> 226.4.2.31152 <> <>	
	72332446	1	DIPSTICK	
8	72378063	1	RELIEF VALVE	DIN71401-CM14X1,5KEG
9	72377226	4	COVER 50 MM	DIN 443-50
	72377227	4	COVER 52 MM	DIN 443-52
11	72313777	2	STUD BOLT	DIN 939 M10X35-8.8
	72313772	1	STUD BOLT --> 258/14808	DIN 939 M8X30-8.8
12	72372811	2	NUT	DIN 934 M10-10A3L
	72372806	1	NUT --> 258/14808	DIN 934 M8-10A3L
13	72375420	2	TOOTHLOCK WASHER	DIN 6797 A10,5
	72375419	1	TOOTHLOCK WASHER --> 258/14808	DIN 6797 A8,4-PHR
14	72311789	2	DISC	DIN 125-10,5-ST.A3L
	72311788	1	DISC --> 258/14808	DIN 125-8,4-ST.A3L

Item	Part Number	Qty	Description Comments	Technical Specification
	72315644	1	HEXAGONAL HEAD BOLT	DIN 933 M8X10-8.8A3L
	72315676	2	HEXAGONAL HEAD BOLT NOT ILLUSTRATED --> 258/14808	DIN 933 M10X12-8.8
	72315089	2	SEALING WASHER NOT ILLUSTRATED --> 258/14808	DIN 7603 A10X16-CU
15	72326267	12	HEXAGONAL HEAD BOLT --> 258/14808 <-- 258/20001	
	72326268	4	HEXAGONAL HEAD BOLT --> 258/14808 <-- 258/20001	
	72326267	14	HEXAGONAL HEAD BOLT <-- 258/14809 --> 258/20000	
	72326268	2	HEXAGONAL HEAD BOLT <-- 258/14809 --> 258/20000	
16	72330749	1	BUSH	
17			NOT USED	
18	72331775	2	NUT --> 258/14808	
	72331775	1	NUT <-- 258/20001	
	72419370	2	NUT	
19			NOT USED	
20	72315650	2	HEXAGONAL HEAD BOLT	DIN 933 M8 X 20-8.8A3L
21	72343896	1	COVER	
22	72376544	1	O-RING	42,2X3-NBR 70 FWN56402
23	72317121	2	SPRING WASHER	DIN 137 B8-MECH.VZK
24	72331774	4	CYLINDER LINER HONED AFTER MOUNTING --> 258/20000	
	72331777	4	CYLINDER LINER FINISHED SIZE --> 258/20000	
	72331778	4	CYLINDER LINER FINISHED SIZE HIGH TIN COLLAR --> 258/20000	
	72340169	4	CYLINDER LINER FINISHED SIZE <-- 258/20001	
	72340170	4	SEAL <-- 258/20001	
25			NOT USED	
26	72332446	1	DIPSTICK <>	
	72326139	1	PIPE PIECE	
27	72376384	1	O-RING	7,3X2,4
28	72331766	4	CYLINDER HEAD GASKET --> 258/14808	
	72326269	X	CYLINDER HEAD GASKET 1,4 MM <-- 258/14809 --> 258/20000 <-- 258/20301	
	72326269	X	CYLINDER HEAD GASKET <-- 258/14809 --> 258/20000 1,3 MM <-- 258/20301	
	72326269	X	CYLINDER HEAD GASKET 1,2 MM 1,3 MM <-- 258/20301	

Thank you so much for reading.  
Please click the “Buy Now!”  
button below to download the  
complete manual.



After you pay.

You can download the most  
perfect and complete manual in  
the world immediately.

Our support email:

[ebooklibonline@outlook.com](mailto:ebooklibonline@outlook.com)