

Page Number	Page Title	Page Reference
01-000-TOC	ENGINE, FUEL AND EXHAUST SYSTEM	01-000-TOC
02-000-TOC	AXLES	02-000-TOC
03-000-TOC	STEERING SYSTEM	03-000-TOC
04-000-TOC	DRIVE TRAIN SYSTEM	04-000-TOC
05-000-TOC	COMPRESSED AIR SYSTEM	05-000-TOC
06-000-TOC	HYDRAULIC SYSTEM	06-000-TOC
07-000-TOC	ELECTRICAL SYSTEM	07-000-TOC
08-000-TOC	CAB	08-000-TOC
09-000-TOC	AIR CONDITIONING AND HEATING SYSTEM	09-000-TOC
10-000-TOC	CHASSIS	10-000-TOC
11-000-TOC	WHEELS	11-000-TOC
12-000-TOC	IMPLEMENT LIFT SYSTEM FRONT	12-000-TOC
13-000-TOC	IMPLEMENT LIFT SYSTEM REAR	13-000-TOC
14-000-TOC	FRONT/REAR LOADERS	14-000-TOC
15-000-TOC	ACCESSORIES	15-000-TOC

FAVORIT 610 (281/00001-99999)
3007

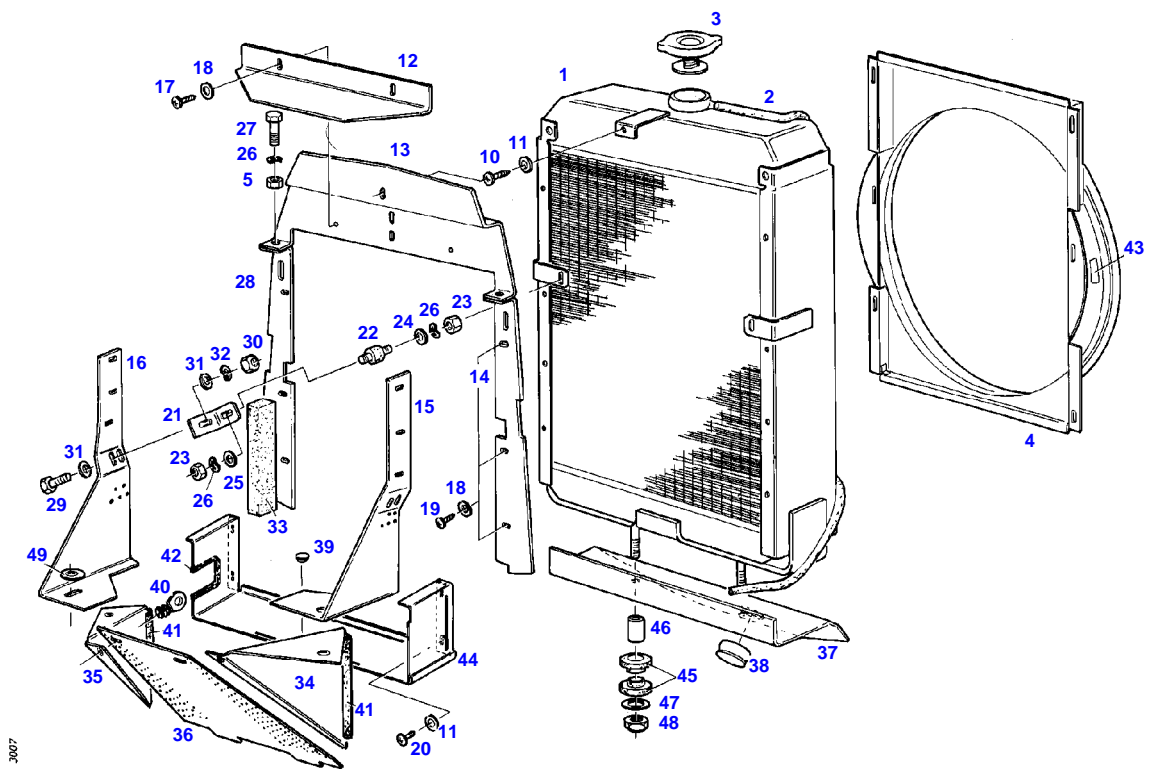

Item	Part Number	Qty	Description Comments	Technical Specification
			WITH AIR CONDITIONING <-- 281/2620	
1	72471948	1	NO LONGER AVAILABLE ><2-5 --> 281/2740 <-- 281/2742 --> 281/2751 <-- 281/2753	
	72349838	1	RADIATOR CORE ><2,3 <-- 281/2741 --> 281/2741 <-- 281/2752 --> 281/2752	
2	72436028	1	HOSE	L=1500FWN65912-10X2-PVC-W-G
3	72340925	1	COLLER LOCKING --> 281/2740 <-- 281/2742 --> 281/2751 <-- 281/2753	
	72478248	1	COLLER LOCKING <-- 281/2741 --> 281/2741 <-- 281/2752 --> 281/2752	
	72329197	8	SPEED NUT <-- 281/2741 --> 281/2741 <-- 281/2752 --> 281/2752 NOT ILLUSTRATED	
4	72362535	1	FAN HOOD --> 281/2740 <-- 281/2742 --> 281/2751 <-- 281/2753	
	72362527	1	FAN COVER <-- 281/2741 --> 281/2741 <-- 281/2752 --> 281/2752	
	72315819	8	SCREW <-- 281/2741 --> 281/2741 <-- 281/2752 --> 281/2752 NOT ILLUSTRATED	DIN7976-ST4,8X13-C-A3L
	72311818	8	DISC <-- 281/2741 --> 281/2741 <-- 281/2752 --> 281/2752 NOT ILLUSTRATED	DIN9021-5,3-140HV-A3L
5	72313266	2	NUT	DIN 934 M6-8A3L
10	72374969	1	SCREW	DIN7976-ST4,8X19-C-A3L
11	72311785	5	DISC	DIN 125-5,3-ST.A3L
12	72405891	1	COVER PANEL	
13	72404928	1	SPLASH PANEL	
14	72404914	1	BARRIER WALL	
15	72405884	1	RETAINER LEFT	
16	72405885	1	RETAINER RIGHT	
17	72315812	2	SCREW	DIN 7981 ST4,2X9,5-F-H-A3
18	72311817	8	DISC	DIN9021-4,3-140HV-A3L
19	72315781	6	SCREW	DIN 7981 ST3,5X9,5-C-H-A3
20	72374968	4	SCREW	DIN7976-ST4,8X9,5-C-A3L
21	72405776	2	ANGLE	
22	72310623	2	BUFFER	
23	72313266	4	NUT	DIN 934 M6-8A3L
24	72311822	2	DISC	DIN9021-6,4-140HV-A3L
25	72311787	2	DISC	DIN 125-6,4-ST.A3L
26	72317120	6	SPRING WASHER	DIN 137 B6-MECH.VZK
27	72315629	2	HEXAGONAL HEAD BOLT	DIN 933 M6 X 12-8.8A3L
28	72404915	1	BARRIER WALL	
29	72315650	2	HEXAGONAL HEAD BOLT	DIN 933 M8 X 20-8.8A3L
30	72313268	2	NUT	DIN 934 M8-8A3L
31	72311788	4	DISC	DIN 125-8,4-ST.A3L
32	72317121	2	SPRING WASHER	DIN 137 B8-MECH.VZK

Item	Part Number	Qty	Description Comments	Technical Specification
33			NO LONGER AVAILABLE	
34	72405887	1	GUSSET PLATE LEFT	
35	72405890	1	GUSSET PLATE RIGHT	
36	72405892	1	FLOOR SHEET	
37			NO LONGER AVAILABLE	
38	72375084	1	LOCKING PLUG F35	SW-F35
39	72426777	1	LOCKING PLUG F5	F5
40	72334276	2	CATCH	
41	72450971	1	SHAPED CORD 1X 170 MM CUT TO LENGTH	L=1000 FWN 63040 C02
42	72451141	1	PROTECTIVE STRIP 1X 120 MM CUT TO LENGTH	L=800 FWN 63040
43	72379109	2	MARKING PLATE	FWN66556-35X68-SCHUTZVORR.N.OE
44	72364553	1	FRAME	
45	72311639	4	RADIATOR DAMPER	
46	72310742	2	BUSH	
47	72311849	2	DISC	
48	72313327	2	NUT	DIN 980-VM14-8-A3L
49	72311793	2	DISC	DIN 125-17-ST.A3L

FAVORIT 610 (281/00001-99999)
339

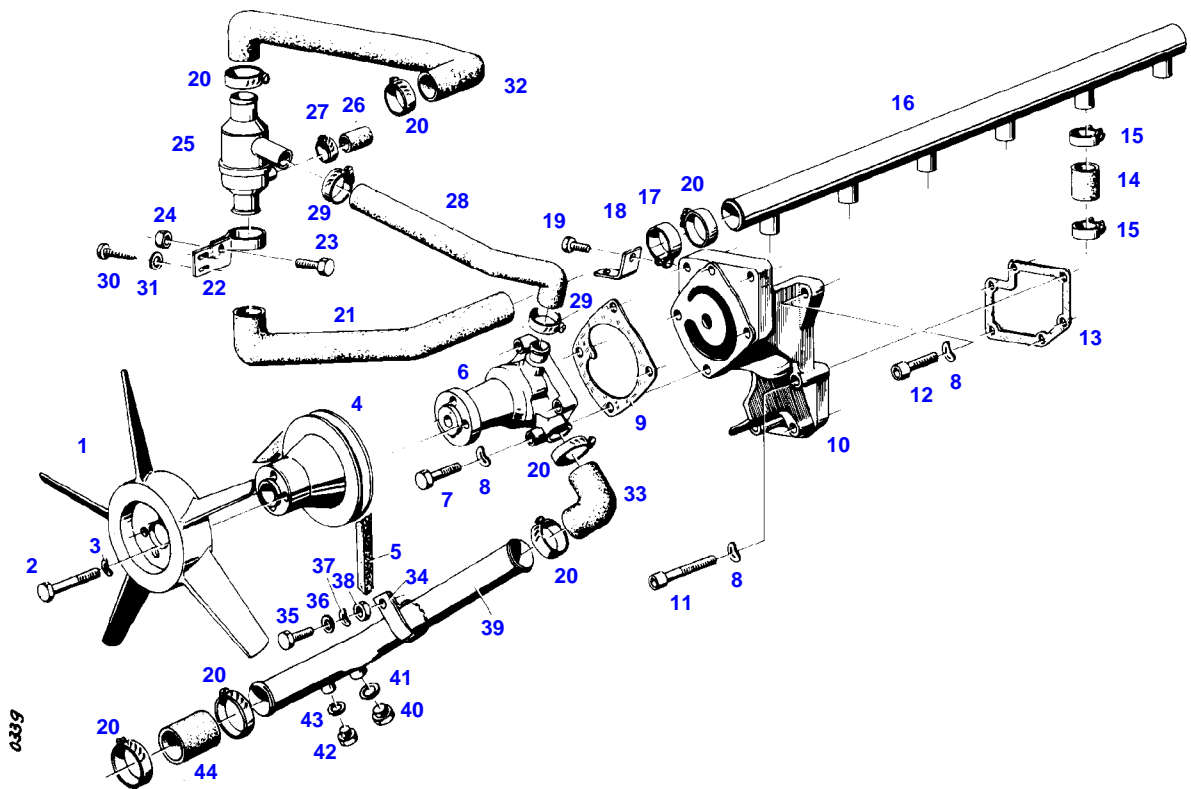

Item	Part Number	Qty	Description Comments	Technical Specification
			CENTRIFUGAL PUMP PIPE WITHOUT AIR CONDITION	
1	72331755	1	FAN	
			<>	
	72394835	4	DISC	
	72331543	1	FAN	
			TROPICAL VERSION	
			<-- 281/0725	
			<>	
	72394835	4	DISC	
2	72315673	4	HEXAGONAL HEAD BOLT	DIN 933 M8X75-8.8A3L
	72394835	4	DISC	
			NOT ILLUSTRATED	
3	72317121	4	SPRING WASHER	DIN 137 B8-MECH.VZK
4	72404901	1	V BELT SHEAVE	
			--> 281/0724	
	72340154	1	V BELT SHEAVE	
			<-- 281/0725	
	72409031	1	INTERMEDIATE RING	
			<-- 281/0725	
			NOT ILLUSTRATED	
5			SEE ALTERNATOR ASSY	
6	72340133	1	CENTRIFUGAL PUMP	
	72340137	1	FACE SEAL	
			NOT ILLUSTRATED	
	72340139	1	COUNTER RING	
			NOT ILLUSTRATED	
	72340140	1	IMPELLER	
			NOT ILLUSTRATED	
7	72315659	4	HEXAGONAL HEAD BOLT	DIN 933 M8X35-8.8
8	72315053	10	SPLIT WASHER	FWN 65208-8-A3L
9	72328678	1	SEAL	
10	72340134	1	INTERMEDIATE PIECE	
11	72315484	4	SOCKET HEAD BOLT	DIN 912 M8X65-10.9A3L
12	72315476	2	SOCKET HEAD BOLT	DIN 912 M8X30-10.9
13			SEE CRANKCASE	
14	72450415	1	HOSE	L=900 DIN73411-22X3,5 R
			1X 30MM	
15	72311167	12	HOSE CLIP	
16	72341138	1	PRESSURE LINE	
17	72337051	2	PIPE CLAMP	
18			NO LONGER AVAILABLE	
			--> 281/0724	
	72326283	1	GUSSET PLATE	
			<-- 281/0725	
19	72315629	2	HEXAGONAL HEAD BOLT	DIN 933 M6 X 12-8.8A3L
			--> 281/0724	
	72315630	2	HEXAGONAL HEAD BOLT	DIN 933 M6X18-8.8A3L
			<-- 281/0725	
20	72311162	7	HOSE CLIP	
21	72404920	1	RUBBER ARCH	
	72404929	1	CLAMP	
			NOT ILLUSTRATED	
	72315626	1	HEXAGONAL HEAD BOLT	DIN 933-M6 X 16-8.8-A3L
			NOT ILLUSTRATED	
	72315052	1	SPLIT WASHER	FWN 65208-6-A3L
			NOT ILLUSTRATED	
	72313266	1	NUT	DIN 934 M6-8A3L
			NOT ILLUSTRATED	

Item	Part Number	Qty	Description Comments	Technical Specification
22	72362035	1	RETAINER --> 281/0530 <> <>	
	72311162	1	HOSE CLIP	
	72311171	1	HOSE CLIP	
	72315789	2	SCREW	DIN 7981 ST4,8X9,5-C-H-A3
	72311171	1	HOSE CLIP <-- 281/0531 NOT ILLUSTRATED	
	72311162	1	HOSE CLIP <-- 281/0531 NOT ILLUSTRATED	
23	72315650	1	HEXAGONAL HEAD BOLT --> 281/0530	DIN 933 M8 X 20-8.8A3L
24	72313268	1	NUT --> 281/0530	DIN 934 M8-8A3L
25	72380194	1	THERMOSTAT	
26	72404925	1	CAP NOT NEEDED WITH HEATING	
27	72311167	1	HOSE CLIP NOT NEEDED WITH HEATING	
28	72404921	1	RUBBER ARCH	
29	72311167	2	HOSE CLIP	
30	72315781	2	SCREW --> 281/0724	DIN 7981 ST3,5X9,5-C-H-A3
	72315789	2	SCREW <-- 281/0725	DIN 7981 ST4,8X9,5-C-H-A3
31	72311817	2	DISC --> 281/0724	DIN9021-4,3-140HV-A3L
	72311787	2	DISC <-- 281/0725	DIN 125-6,4-ST.A3L
32	72405866	1	RUBBER ARCH	
33	72399873	1	RUBBER ARCH	
34	72394567	1	FASTENING COLLAR	
35	72315631	1	HEXAGONAL HEAD BOLT	DIN 933 M6 X 20-8.8A3L
36	72311822	1	DISC	DIN9021-6,4-140HV-A3L
37	72317120	1	SPRING WASHER	DIN 137 B6-MECH.VZK
38	72313266	1	NUT	DIN 934 M6-8A3L
39	72362033	1	SUCTION LINE HEATING	
	72362036	1	SUCTION LINE WITHOUT HEATING	
40	72315802	1	SCREW --> 281/2329 WITHOUT HEATING	DIN 7604 AM22X1,5-ST
41	72315101	1	SEALING WASHER --> 281/2329 WITHOUT HEATING	DIN 7603 A22X27-CU
42	72315799	1	PLUG	DIN 7604 AM14X1,5-A3L
43	72315094	1	SEALING WASHER	DIN 7603 A14X18-CU
44	72450416	1	HOSE 1X 60MM CUT TO LENGTH	L=120 DIN73411-35X

FAVORIT 610 (281/00001-99999)
3008

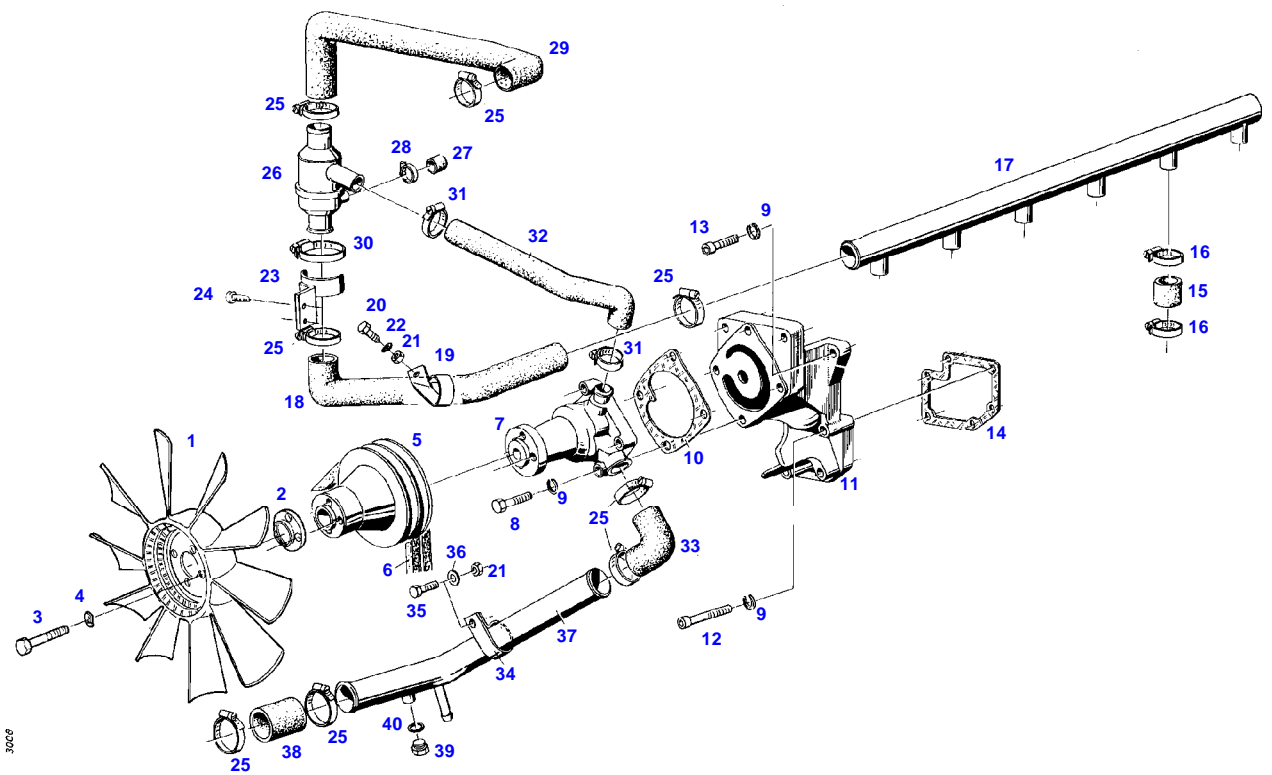

Item	Part Number	Qty	Description Comments	Technical Specification
			CENTRIFUGAL PUMP PIPE WITH AIR CONDITIONING <-- 281/2620	
1	72380190	1	FAN	KST.
			<>	
	72394835	4	DISC	
2	72405888	1	INTERMEDIATE RING	
3	72315673	4	HEXAGONAL HEAD BOLT	DIN 933 M8X75-8.8A3L
	72394835	4	DISC	
			NOT ILLUSTRATED	
4	72317121	4	SPRING WASHER	DIN 137 B8-MECH.VZK
5	72405781	1	V BELT SHEAVE	
6				
			SEE ALTERNATOR ASSY	
7	72340133	1	CENTRIFUGAL PUMP	
	72340137	1	FACE SEAL	
			NOT ILLUSTRATED	
	72340139	1	COUNTER RING	
			NOT ILLUSTRATED	
	72340140	1	IMPELLER	
			NOT ILLUSTRATED	
8	72315659	4	HEXAGONAL HEAD BOLT	DIN 933 M8X35-8.8
9	72315053	10	SPLIT WASHER	FWN 65208-8-A3L
10	72328678	1	SEAL	
11	72340134	1	INTERMEDIATE PIECE	
12	72315484	4	SOCKET HEAD BOLT	DIN 912 M8X65-10.9A3L
13	72315476	2	SOCKET HEAD BOLT	DIN 912 M8X30-10.9
14				
			SEE CRANKCASE	
15	72450415	1	HOSE	L=900 DIN73411-22X3,5 R
			1X 30MM	
16	72311167	12	HOSE CLIP	
17	72341138	1	PRESSURE LINE	
18	72404920	1	RUBBER ARCH	
19	72404929	1	CLAMP	
20	72315626	1	HEXAGONAL HEAD BOLT	DIN 933-M6 X 16-8.8-A3L
21	72313266	1	NUT	DIN 934 M6-8A3L
22	72317120	1	SPRING WASHER	DIN 137 B6-MECH.VZK
23	72362035	1	RETAINER	
24	72374968	2	SCREW	DIN7976-ST4,8X9,5-C-A3L
25	72311162	8	HOSE CLIP	
26	72380194	1	THERMOSTAT	
27	72404925	1	CAP	
			NOT NEEDED WITH HEATING	
28	72311167	1	HOSE CLIP	
			NOT NEEDED WITH HEATING	
29	72405866	1	RUBBER ARCH	
30	72311171	1	HOSE CLIP	
31	72311167	2	HOSE CLIP	
32	72404921	1	RUBBER ARCH	
33	72399873	1	RUBBER ARCH	
34	72394567	1	FASTENING COLLAR	
35	72315631	1	HEXAGONAL HEAD BOLT	DIN 933 M6 X 20-8.8A3L
36	72311822	1	DISC	DIN9021-6,4-140HV-A3L
37	72362033	1	SUCTION LINE	
38	72450416	1	HOSE	L=120 DIN73411-35X
			1X 60MM	
			CUT TO LENGTH	
39	72315799	1	PLUG	DIN 7604 AM14X1,5-A3L
40	72315094	1	SEALING WASHER	DIN 7603 A14X18-CU

FAVORIT 610 (281/00001-99999)
2520

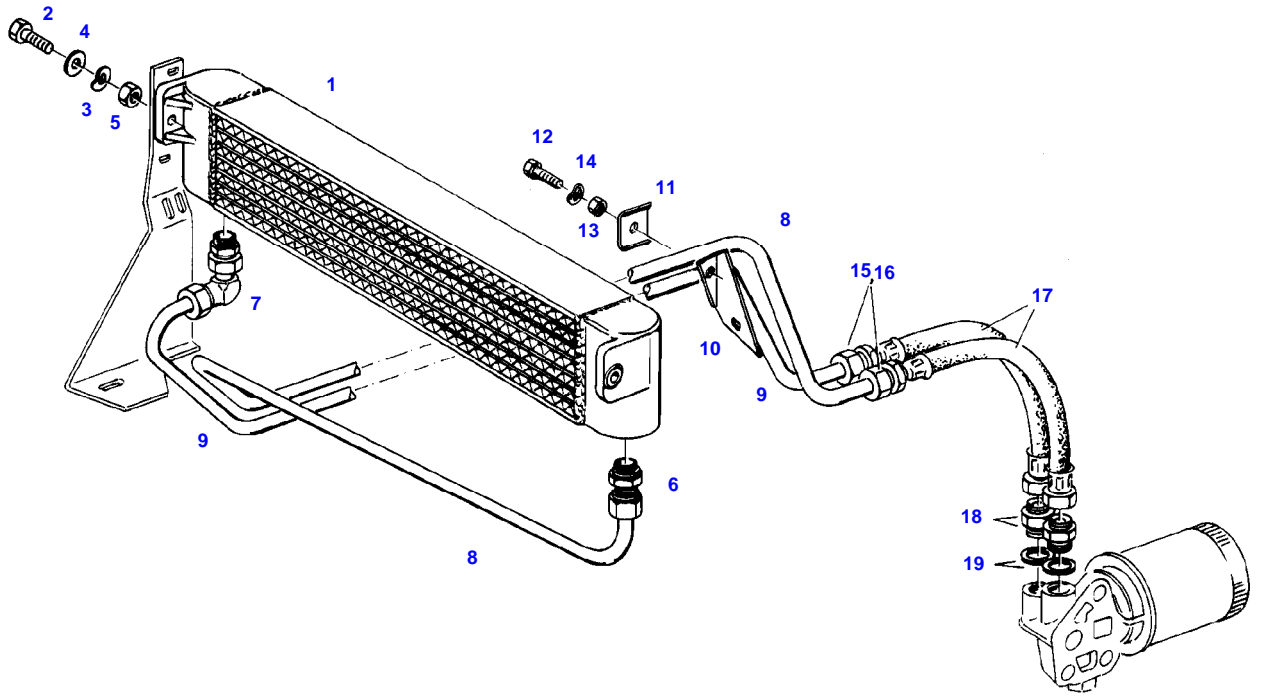

2520

Item	Part Number	Qty	Description Comments	Technical Specification
			WITH AIR CONDITIONING <-- 281/2620	
1	72349803	1	OIL/AIR COOLER	
2	72315650	2	HEXAGONAL HEAD BOLT	DIN 933 M8 X 20-8.8A3L
3	72317121	2	SPRING WASHER	DIN 137 B8-MECH.VZK
4	72311788	2	DISC	DIN 125-8,4-ST.A3L
5	72313268	2	NUT	DIN 934 M8-8A3L
6	72316324	1	SCREW NECK	DIN 3901-L15B-M-ST-A3
	72315164	X	CUTTING RING	DIN 3861-L15-ST-A3L
	72313367	X	CONNECTING NUT	DIN3870 AL15/M22X1.5-9S20K A3L
7	72312097	1	ADJUSTABLE W-THREADED CONNECTION BODY	FWN65843-L15-A3L
	72316324	1	SCREW NECK	DIN 3901-L15B-M-ST-A3
	72315164	X	CUTTING RING	DIN 3861-L15-ST-A3L
	72313367	X	CONNECTING NUT	DIN3870 AL15/M22X1.5-9S20K A3L
8	72405889	1	PIPE	
9	72405997	1	PIPE	
10	72405996	1	RETAINER	
11	72311266	1	CLIP	
12	72315634	1	HEXAGONAL HEAD BOLT	DIN 933 M6X30-8.8A3L
13	72313266	1	NUT	DIN 934 M6-8A3L
14	72317120	1	SPRING WASHER	DIN 137 B6-MECH.VZK
15	72313367	2	CONNECTING NUT	DIN3870 AL15/M22X1.5-9S20K A3L
16	72315164	2	CUTTING RING	DIN 3861-L15-ST-A3L
17	72362590	2	OIL LINE	
18	72393673	2	SCREW NECK	
19	72376031	2	SEALING WASHER	DIN 7603 A20X24-CU

FAVORIT 610 (281/00001-99999)
6084

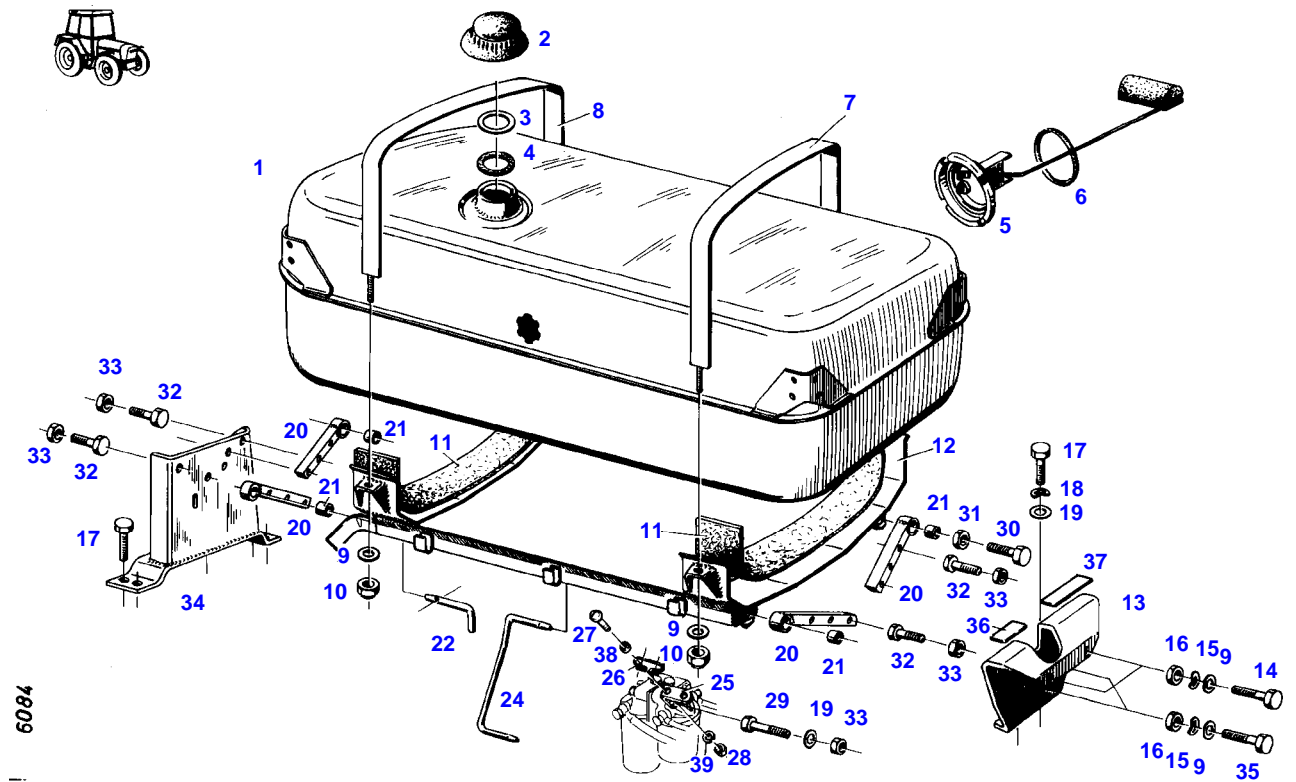

Item	Part Number	Qty	Description Comments	Technical Specification
1	72364691	1	FUEL TANK --> 281/0368 <> <>	
	72315802	1	SCREW	DIN 7604 AM22X1,5-ST
	72409020	1	REDUCER	
	72315104	1	SEALING WASHER	DIN 7603 A26X31-CU
	72350303	1	FUEL CAP	
	72315101	1	SEALING WASHER	DIN 7603 A22X27-CU
2	72380143	1	FUEL CAP ><3-4 --> 281/0368 <>	M.BELUEF
	72394572	1	PLASTIC CAP	
	72350303	1	FUEL CAP ><2-4 <-- 281/0369	
	72394572	1	PLASTIC CAP	
3	72330726	1	SEAL BLAU	
4	72330725	1	SEAL BLAU	
	72312304	1	RUBBER SEAL KOEHLER	
5	72613427	1	FUEL LEVEL SENSOR ><5+6	
6	72315169	1	SEALING WASHER	
7	72362041	1	BAND CLAMP	
8	72362042	1	BAND CLAMP	
9	72311788	8	DISC	DIN 125-8,4-ST.A3L
10	72313320	4	NUT	DIN6925-M8-8-A3L
11	72404934	2	FELT TAPE	
12	72364628	1	FRAME	
13	72409303	1	CONSOLE --> 281/2747 <> <>	
	72405619	1	COVER PANEL	
	72380203	1	FAN	
14	72315659	2	HEXAGONAL HEAD BOLT	DIN 933 M8X35-8.8
15	72315053	4	SPLIT WASHER	FWN 65208-8-A3L
16	72313268	4	NUT	DIN 934 M8-8A3L
17	72315678	7	HEXAGONAL HEAD BOLT	DIN 933 M10X20-8.8
18	72315054	2	SPLIT WASHER	FWN 65208-10-A3L
19	72311789	3	DISC	DIN 125-10,5-ST.A3L
20	72404942	4	SUPPORT ARM	
21	72310644	4	RUBBER BUSHING	
22	72397322	1	BEARING PIN	
	72311183	2	HAIR COTTER PIN NOT ILLUSTRATED	DIN 11024-4-A3L
24	72404936	1	BEARING PIN --> 281/0105 <> <>	
	72353861	1	RETAINER	
	72404938	1	ANGLE	
	72315411	2	FLAT HEAD CAPSCREW	DIN 85 M5X20-4.8A3L
	72313264	2	NUT	DIN 934 M5-8A3L
	72315700	1	HEXAGONAL HEAD BOLT	DIN 933 M10X100-8.8
	72313804	1	TENSIONING PIN --> 281/0105 NOT ILLUSTRATED	ISO8752-4X22-A-ST-ZNPHR10F-KOE
25	72404938	1	ANGLE <-- 281/0106	
26	72399331	1	RETAINER <-- 281/0106	
27	72315619	2	HEXAGONAL HEAD BOLT <-- 281/0106	DIN 933 M5X16-8.8A3L

Item	Part Number	Qty	Description Comments	Technical Specification
28	72313264	2	NUT <-- 281/0106	DIN 934 M5-8A3L
29	72315700	1	HEXAGONAL HEAD BOLT <-- 281/0106 --> 281/0828	DIN 933 M10X100-8.8
	72315685	1	HEXAGONAL HEAD BOLT <-- 281/0829	DIN 933 M10X30-8.8A3L
30	72374215	2	HEXAGONAL HEAD BOLT	DIN 931 M12X65-8.8
31	72313325	2	NUT	DIN 980-VM12-8-A3L
32	72315693	8	HEXAGONAL HEAD BOLT --> 281/2843	DIN 933 M10X45-8.8A3L
	72315693	7	HEXAGONAL HEAD BOLT <-- 281/2844	DIN 933 M10X45-8.8A3L
	72374898	1	SOCKET HEAD BOLT <-- 281/2844	DIN 6912-M10X45-8.8
33	72313272	9	NUT	DIN 934 M10-8A3L
34	72364688	1	CONSOLE	
35	72315663	3	HEXAGONAL HEAD BOLT	DIN 933 M8X40-8.8A3L
36	72404939	1	BAND	
37	72404943	1	BAND	
38	72311818	2	DISC	DIN9021-5,3-140HV-A3L
39	72315051	2	SPLIT WASHER	FWN 65208-5-A3L

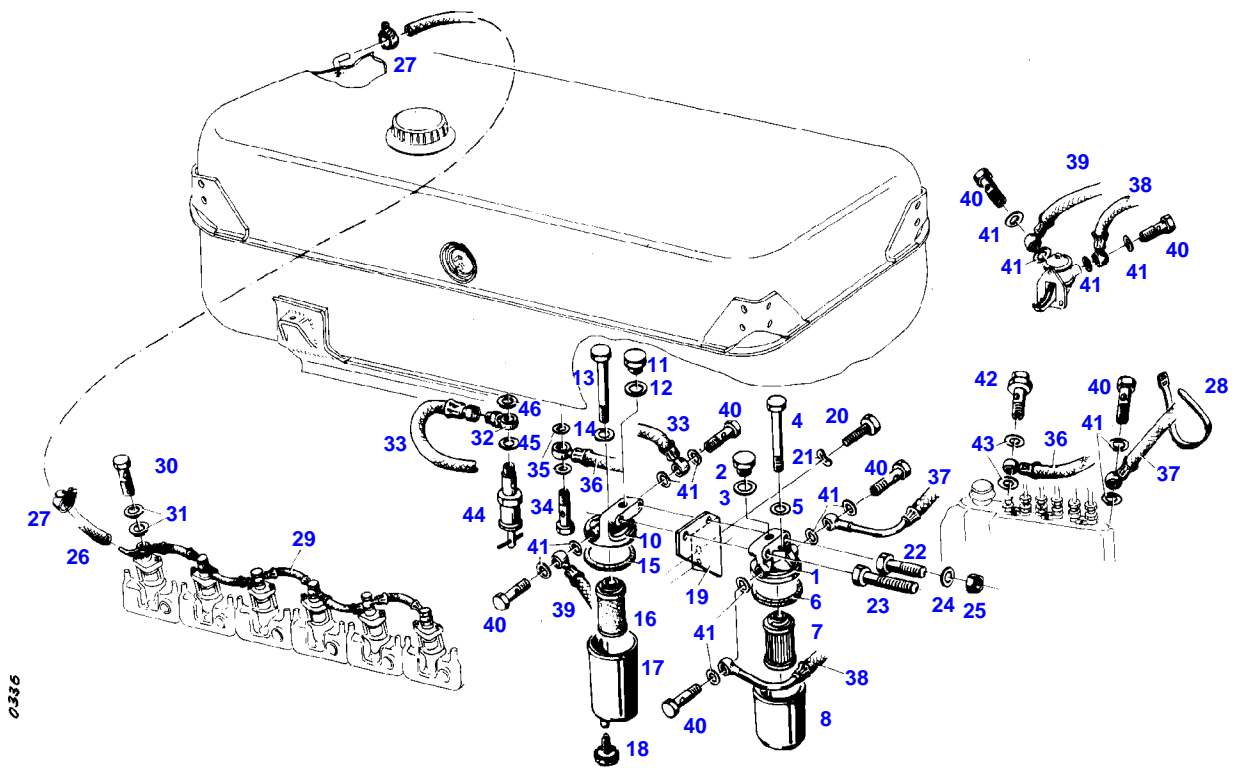

Item	Part Number	Qty	Description Comments	Technical Specification
			FUEL LINES --> 281/0828	
1	72340109	1	FUEL FILTER ><2-8	
2	72340116	1	SCREW	
3	72315094	1	SEALING WASHER	DIN 7603 A14X18-CU
4	72315525	1	HEXAGONAL HEAD BOLT	DIN 931 M8 X 90-8.8A3L
5	72315086	1	SEALING WASHER	DIN 7603 A8X11,5-CU
6	72327233	1	SEAL	
7	72320177	1	FILTER BOX	
8				
			NOT AVAILABLE IN SINGLE PARTS	
10	72340111	1	FUEL FILTER ><11-18	
11	72340116	1	SCREW	
12	72315094	1	SEALING WASHER	DIN 7603 A14X18-CU
13	72315525	1	HEXAGONAL HEAD BOLT	DIN 931 M8 X 90-8.8A3L
14	72315086	1	SEALING WASHER	DIN 7603 A8X11,5-CU
15	72327233	1	SEAL	
16	72340113	1	FELT PIPE INSERT	
17				
			NOT AVAILABLE IN SINGLE PARTS	
18	72340115	1	DRAIN PLUG	
19	72404935	1	RETAINING BRACKET	
20	72315642	2	HEXAGONAL HEAD BOLT	DIN 933 M8 X 16-8.8A3L
21	72315053	2	SPLIT WASHER	FWN 65208-8-A3L
22	72374451	2	HEXAGONAL HEAD BOLT	DIN 933 M10X85-8.8
23				
			SEE FUEL TANK	
24	72311789	1	DISC	DIN 125-10,5-ST.A3L
25	72313272	1	NUT	DIN 934 M10-8A3L
26	72435830	1	PRESSURE HOSE 1390 MM CUT TO LENGTH	L=2100
27	72438345	2	HOSE CLIP	
28	72316916	3	CABLE STRAP	FWN 66650 B175X4-SW
29	72340112	1	LEAKAGE OIL LINE	
30	72315809	6	BANJO BOLT	DIN 7643-4-5-A3L
31	72315086	12	SEALING WASHER	DIN 7603 A8X11,5-CU
32	72377538	1	BANJO UNION	
33	72362043	1	FUEL LINE	
34	72315807	1	BANJO BOLT	DIN 7643-8-3-A3L
35	72315090	2	SEALING WASHER	DIN 7603 A12X15,5-CU
36	72364689	1	FUEL LINE	
37	72362045	1	FUEL LINE	
38	72362046	1	FUEL LINE	
39	72363812	1	FUEL LINE	
40	72315808	7	BANJO BOLT	DIN 7643-10-3-A3L
41	72315094	14	SEALING WASHER	DIN 7603 A14X18-CU
42	72380268	1	BLEED AND DRAIN VALVE	
43	72315095	2	SEALING WASHER	DIN 7603 A14X20-CU
44	72380161	1	FUEL SHUT-OFF VALVE	
45	72315099	1	SEALING WASHER	DIN 7603 A18X22-CU
46	72315098	1	SEALING WASHER	DIN 7603 A16X22-CU

FAVORIT 610 (281/00001-99999)
39732

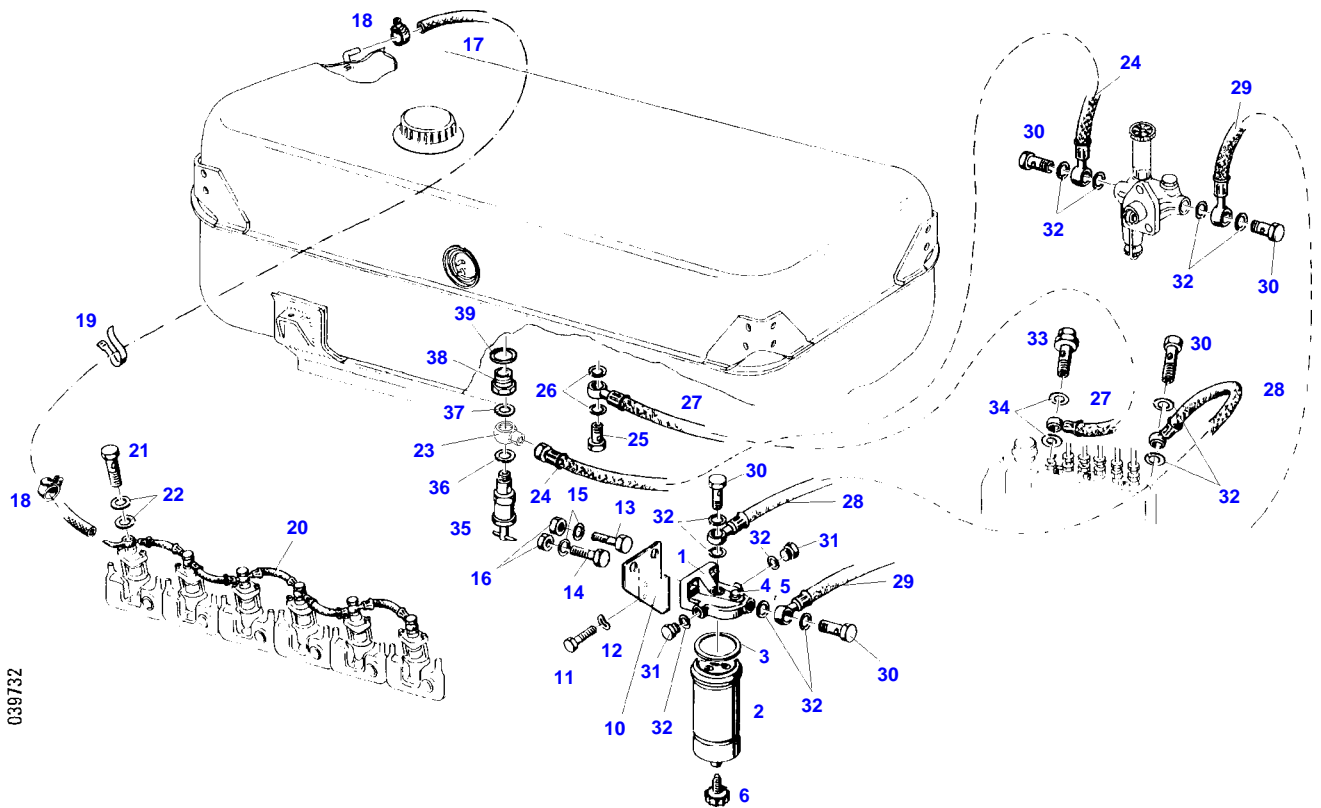

Item	Part Number	Qty	Description Comments	Technical Specification
			FUEL LINES <-- 281/0829	
1	72350307	1	FUEL FILTER ><1-3	
2	72416928	1	FILTER BOX ><2+3	
3	72314995	1	RUBBER RING	
4	72323290	1	BLEED SCREW	
5	72315084	1	SEALING WASHER	DIN 7603 A6X10-CU
6	72330827	1	DRAIN SCREW	
10	72404935	1	RETAINING BRACKET	
11	72315642	2	HEXAGONAL HEAD BOLT	DIN 933 M8 X 16-8.8A3L
12	72315053	2	SPLIT WASHER	FWN 65208-8-A3L
13	72315685	1	HEXAGONAL HEAD BOLT	DIN 933 M10X30-8.8A3L
14			SEE FUEL TANK	
15	72311789	2	DISC	DIN 125-10,5-ST.A3L
16	72313272	2	NUT	DIN 934 M10-8A3L
17	72435830	1	PRESSURE HOSE 1390 MM CUT TO LENGTH	L=2100
18	72438345	2	HOSE CLIP	
19	72316916	3	CABLE STRAP	FWN 66650 B175X4-SW
20	72340112	1	LEAKAGE OIL LINE	
21	72315809	6	BANJO BOLT	DIN 7643-4-5-A3L
22	72315086	12	SEALING WASHER	DIN 7603 A8X11,5-CU
23	72377538	1	BANJO UNION	
24	72364540	1	FUEL LINE	
25	72315807	1	BANJO BOLT	DIN 7643-8-3-A3L
26	72315090	2	SEALING WASHER	DIN 7603 A12X15,5-CU
27	72364689	1	FUEL LINE	
28	72362049	1	FUEL LINE	
29	72362048	1	FUEL LINE	
30	72315808	5	BANJO BOLT	DIN 7643-10-3-A3L
31	72315799	2	PLUG	DIN 7604 AM14X1,5-A3L
32	72315094	12	SEALING WASHER	DIN 7603 A14X18-CU
33	72317103	1	BLEED AND DRAIN VALVE	
34	72315095	2	SEALING WASHER	DIN 7603 A14X20-CU
35	72380161	1	FUEL SHUT-OFF VALVE	
36	72315099	1	SEALING WASHER	DIN 7603 A18X22-CU
37	72315098	1	SEALING WASHER	DIN 7603 A16X22-CU
38	72409020	1	REDUCER	
39	72315104	1	SEALING WASHER	DIN 7603 A26X31-CU
40	72393682	1	MARKING PLATE ARABIAN-ENGLISH NOT ILLUSTRATED	

FAVORIT 610 (281/00001-99999)
340

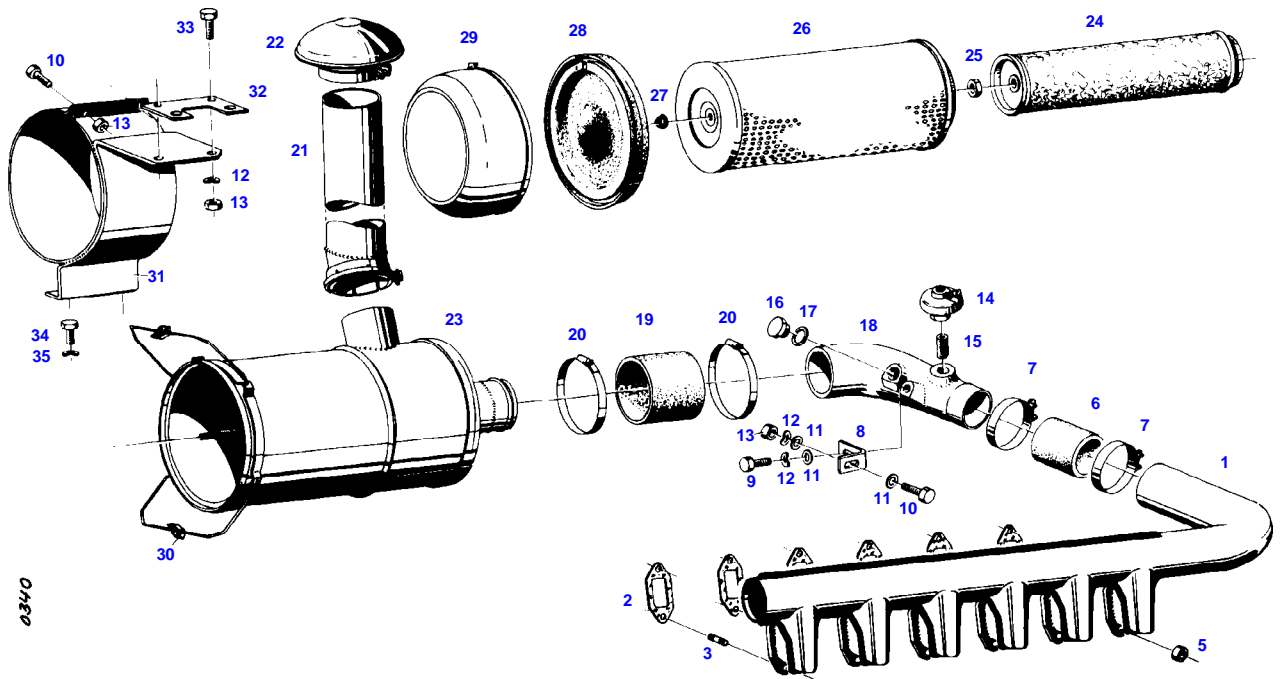

0340

Item	Part Number	Qty	Description Comments	Technical Specification
PICLON				
1	72340719	1	INTAKE MANIFOLD	
	72373975	1	SCREW FOR TEMPERATURE RANGE 2 TRACTORS WITHOUT COLD START DEVICE NOT ILLUSTRATED	DIN 910 M20X1,5-ST
	72376031	1	SEALING WASHER FOR TEMPERATURE RANGE 2 TRACTORS WITHOUT COLD START DEVICE NOT ILLUSTRATED	DIN 7603 A20X24-CU
2	72332145	6	MOLDED SEAL	
3	72373922	12	STUD BOLT	DIN 835-M10X25-8.8
5	72313272	12	NUT	DIN 934 M10-8A3L
6	72450420	1	HOSE 1X 80MM CUT TO LENGTH	L=120 DIN73411-70X5 R
7	72373528	2	HOSE CLIP	
8	72404947	1	ANGLE	
9	72315646	1	HEXAGONAL HEAD BOLT	DIN 933 M8X18-8.8A3L
10	72315653	3	HEXAGONAL HEAD BOLT	DIN 933 M8 X 25-8.8A3L
11	72311788	3	DISC	DIN 125-8,4-ST.A3L
12	72315053	4	SPLIT WASHER	FWN 65208-8-A3L
13	72313268	5	NUT	DIN 934 M8-8A3L
14	72316876	1	MAINTENANCE SWITCH <>	
	72379175	0	WIRE	B1,5 DIN72551/6.51 SCHWARZ
	72380356	1	CABLE LUG	
	72314686	1	PLUG IN SLEEVE	
15	72339032	1	THREADED SOCKET	
16	72315442	1	PLUG	DIN 908 M22X1,5-ST
17	72315101	1	SEALING WASHER	DIN 7603 A22X27-CU
18	72404946	1	INTAKE MANIFOLD	
19	72395094	1	RUBBER PIECE	
20	72311173	2	HOSE CLIP	
21	72340120	1	INTAKE MANIFOLD	
22	72332141	1	RAIN CAP	
23	72349691	1	AIR FILTER ><23-30	
	72340122	1	DIFFUSER NOT ILLUSTRATED	
24	72332148	1	SAFETY CARTRIDGE	
25	72313299	1	NUT	DIN 936-M16X1,5-17H
26	72332142	1	MICRO-TOP CARTRIDGE	
27	72339030	1	COLLAR NUT	
28	72332146	1	INTERMEDIATE PLATE	
29	72340121	1	CUP	
30	72326152	2	TENSIONING DEVICE	
	72340124	2	HOLDER NOT ILLUSTRATED	
	72340123	2	RETAINER NOT ILLUSTRATED	
31	72364630	1	BAND CLAMP <>	
	72409006	1	RETAINING SHEET METAL	
32	72404945	1	RETAINING SHEET METAL	
33	72315642	2	HEXAGONAL HEAD BOLT	DIN 933 M8 X 16-8.8A3L
34	72315645	2	HEXAGONAL HEAD BOLT	DIN 933 M8 X 12-8.8A3L
35	72317121	2	SPRING WASHER	DIN 137 B8-MECH.VZK
36	72404957	1	ABSORPTION INDICATOR (1,3) NOT ILLUSTRATED	

FAVORIT 610 (281/00001-99999)
882

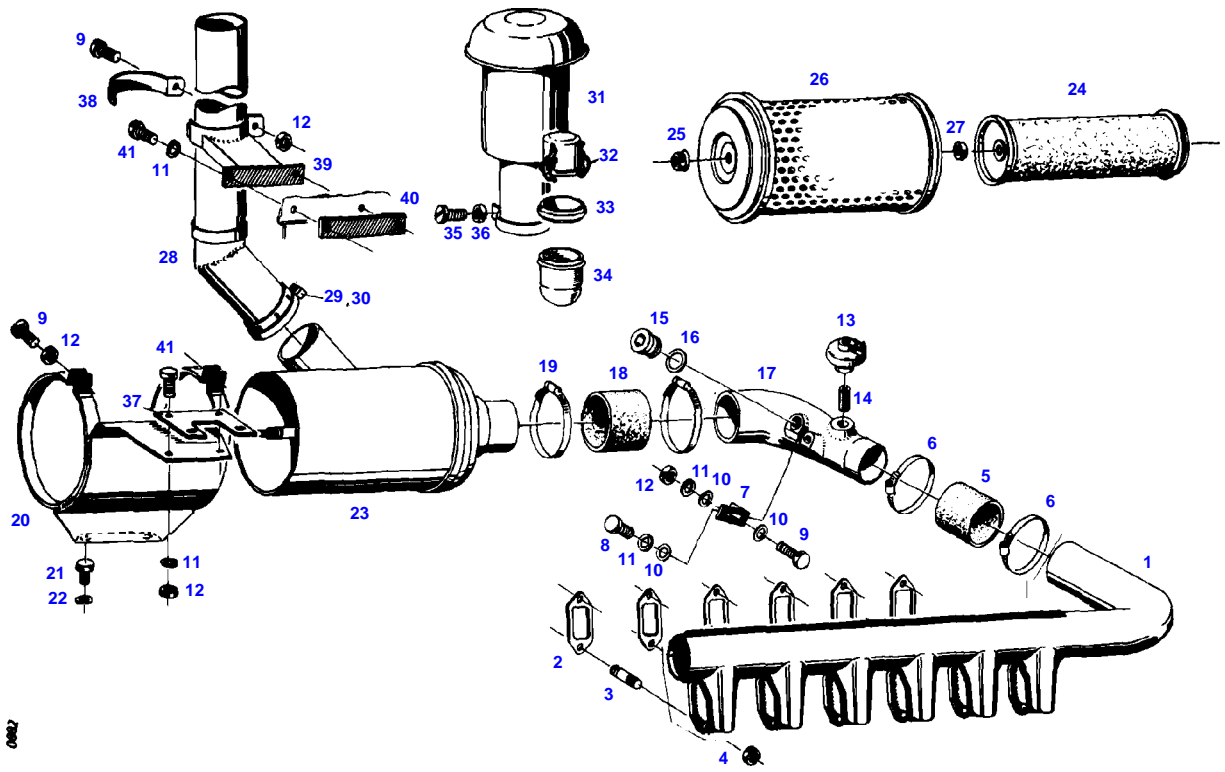

0002

Item	Part Number	Qty	Description Comments	Technical Specification
PICO				
1	72340719	1	INTAKE MANIFOLD	
	72373975	1	SCREW FOR TEMPERATURE RANGE 2 TRACTORS WITHOUT COLD START DEVICE NOT ILLUSTRATED	DIN 910 M20X1,5-ST
	72376031	1	SEALING WASHER FOR TEMPERATURE RANGE 2 TRACTORS WITHOUT COLD START DEVICE NOT ILLUSTRATED	DIN 7603 A20X24-CU
2	72332145	6	MOLDED SEAL	
3	72373922	12	STUD BOLT	DIN 835-M10X25-8.8
4	72313272	12	NUT	DIN 934 M10-8A3L
5	72450420	1	HOSE 1X 80MM CUT TO LENGTH	L=120 DIN73411-70X5 R
6	72373528	2	HOSE CLIP	
7	72404947	1	ANGLE	
8	72315646	1	HEXAGONAL HEAD BOLT	DIN 933 M8X18-8.8A3L
9	72315653	4	HEXAGONAL HEAD BOLT	DIN 933 M8 X 25-8.8A3L
10	72311788	3	DISC	DIN 125-8,4-ST.A3L
11	72315053	6	SPLIT WASHER	FWN 65208-8-A3L
12	72313268	6	NUT	DIN 934 M8-8A3L
13	72316876	1	MAINTENANCE SWITCH <>	
	72314686	1	PLUG IN SLEEVE	
	72380356	1	CABLE LUG	
	72379175	0	WIRE	B1,5 DIN72551/6.51 SCHWARZ
14	72339032	1	THREADED SOCKET	
15	72315442	1	PLUG	DIN 908 M22X1,5-ST
16	72315101	1	SEALING WASHER	DIN 7603 A22X27-CU
17	72404946	1	INTAKE MANIFOLD	
18	72395094	1	RUBBER PIECE	
19	72311173	2	HOSE CLIP	
20	72364631	1	RETAINER <>	
	72409006	1	RETAINING SHEET METAL	
21	72315645	2	HEXAGONAL HEAD BOLT	DIN 933 M8 X 12-8.8A3L
22	72317121	2	SPRING WASHER	DIN 137 B8-MECH.VZK
23	72349678	1	AIR FILTER ><24-27	
24	72339772	1	SAFETY CARTRIDGE	
25	72313243	1	COLLAR NUT	
26	72339771	1	MICRO-TOP CARTRIDGE	
27	72313299	1	NUT	DIN 936-M16X1,5-17H
28	72349681	1	INTAKE MANIFOLD ><29,30 --> 281/2619 <> <>	
	72349682	1	CYCLONE AIR CLEANER	
29			NO LONGER AVAILABLE	
30	72372783	1	SQUARE NUT	DIN 557 M6-5 A3L
31	72349680	1	CYCLONE AIR CLEANER ><32-36 --> 281/2619	
	72349682	1	CYCLONE AIR CLEANER ><32-36 <-- 281/2620	
32	72321921	2	CATCH	
33	72330736	1	FUNNEL	
34	72320204	1	CONTAINER	
35	72315685	1	HEXAGONAL HEAD BOLT	DIN 933 M10X30-8.8A3L

Item	Part Number	Qty	Description Comments	Technical Specification
36	72313272	1	NUT	DIN 934 M10-8A3L
37	72404945	1	RETAINING SHEET METAL	
38	72404790	1	CLAMP	
39	72361972	1	RETAINER	
40	72409381	1	PLATE LINK	
41	72315642	4	HEXAGONAL HEAD BOLT	DIN 933 M8 X 16-8.8A3L
42	72404957	1	ABSORPTION INDICATOR NOT ILLUSTRATED	

FAVORIT 610 (281/00001-99999)
341

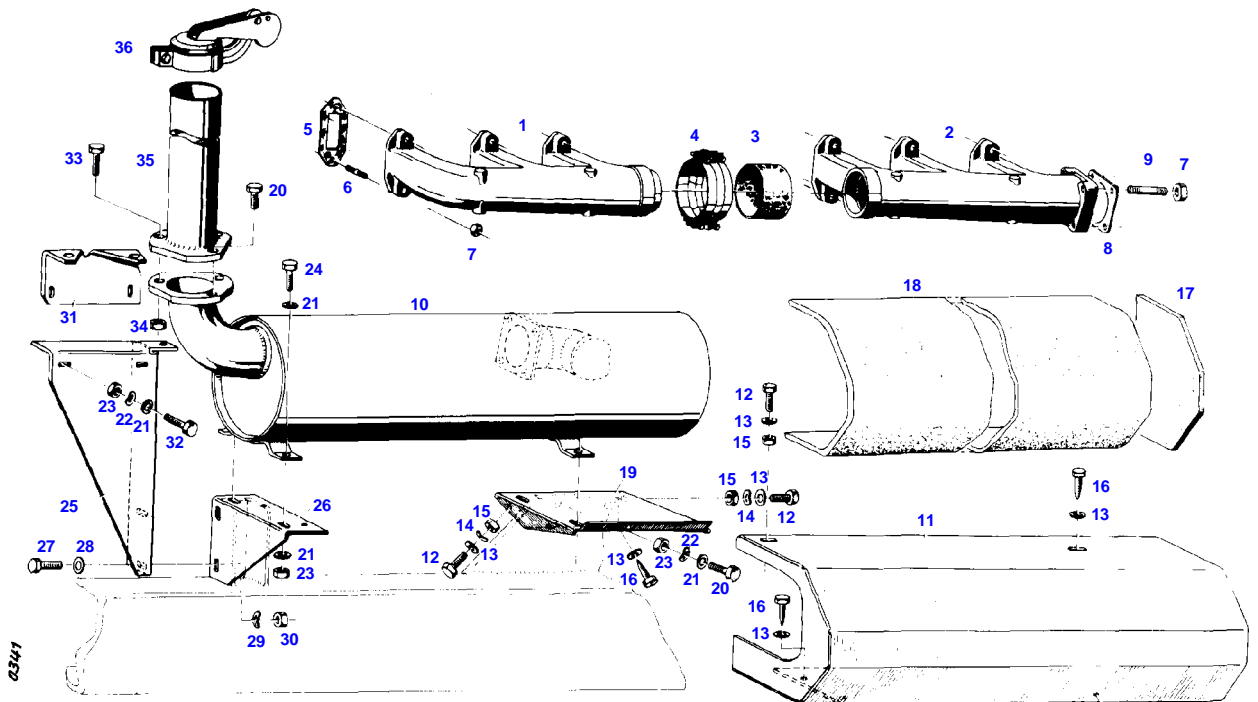

Item	Part Number	Qty	Description Comments	Technical Specification
1	72331546	1	EXHAUST HALF	
2	72332127	1	EXHAUST HALF --> 281/2847	
	72340166	1	EXHAUST HALF <-- 281/2848	
3	72331548	1	ASBESTOS-RING	
4	72331550	1	CRIMPED CLIP	
5	72332145	6	MOLDED SEAL	
6	72374647	12	STUD BOLT	DIN 939-M10X40-8.8
7	72373015	16	NUT --> 281/2847	DIN70615-M10-8-A3B
	72373015	12	NUT <-- 281/2848	DIN70615-M10-8-A3B
	72313269	3	NUT <-- 281/2848 INAPPLICABLE WITH EXHAUST BRAKE	DIN 934 M8-8C2A
8	72331323	1	SQUARE SEAL --> 281/2847 INAPPLICABLE WITH EXHAUST BRAKE	
	72407298	1	MOLDED SEAL <-- 281/2848 INAPPLICABLE WITH EXHAUST BRAKE	
9	72374644	4	STUD BOLT --> 281/2847 INAPPLICABLE WITH EXHAUST BRAKE	DIN 939 M10X25-10.9
	72313770	3	STUD BOLT <-- 281/2848 INAPPLICABLE WITH EXHAUST BRAKE	FWN64891-M8X20-8.8
10	72362053	1	MUFFLER --> 281/2847	
	72362058	1	MUFFLER <-- 281/2848	
	72362053	1	MUFFLER <-- 281/2848 ENGINE BRAKE	
11	72364700	1	TRIM PANEL	
12	72315629	5	HEXAGONAL HEAD BOLT	DIN 933 M6 X 12-8.8A3L
13	72311822	9	DISC	DIN9021-6,4-140HV-A3L
14	72315052	5	SPLIT WASHER	FWN 65208-6-A3L
15	72313266	4	NUT	DIN 934 M6-8A3L
16	72315820	3	SCREW	DIN7976-ST6,3X13-C-A3L
17	72404951	1	INSULATING PLATE	
18	72404952	1	INSULATING PLATE	
19	72404950	1	CONSOLE	
20	72315657	2	HEXAGONAL HEAD BOLT	DIN 933 M8 X 30-8.8A3L
	72315660	1	HEXAGONAL HEAD BOLT	DIN 933 M8X35-8.8A3L
21	72311788	14	DISC	DIN 125-8,4-ST.A3L
22	72315053	4	SPLIT WASHER	FWN 65208-8-A3L
23	72313268	8	NUT	DIN 934 M8-8A3L
24	72315642	4	HEXAGONAL HEAD BOLT	DIN 933 M8 X 16-8.8A3L
25	72406004	1	BRACKET	
26	72404949	1	RETAINING BRACKET	
27	72315685	2	HEXAGONAL HEAD BOLT	DIN 933 M10X30-8.8A3L
28	72311789	2	DISC	DIN 125-10,5-ST.A3L
29	72315054	2	SPLIT WASHER	FWN 65208-10-A3L
30	72313272	2	NUT	DIN 934 M10-8A3L
31	72404948	1	RETAINING BRACKET	
	72356507	1	BAND CLAMP <-- 281/0386 NOT ILLUSTRATED	
	72313320	2	NUT <-- 281/0386 NOT ILLUSTRATED	DIN6925-M8-8-A3L
	72311789	3	DISC <-- 281/0386 NOT ILLUSTRATED	DIN 125-10,5-ST.A3L

Item	Part Number	Qty	Description Comments	Technical Specification
32	72315653	2	HEXAGONAL HEAD BOLT	DIN 933 M8 X 25-8.8A3L
33	72315660	2	HEXAGONAL HEAD BOLT	DIN 933 M8X35-8.8A3L
	72315665	2	HEXAGONAL HEAD BOLT --> 281/0385 <-- 281/0386	DIN 933 M8X45-8.8A3L
34	72313269	3	NUT	DIN 934 M8-8C2A
35	72362056	1	EXHAUST PIPE	
	72409384	1	SEAL NOT ILLUSTRATED	
36	72340125	1	EXHAUST WEATHER CAP	

FAVORIT 610 (281/00001-99999)
2810

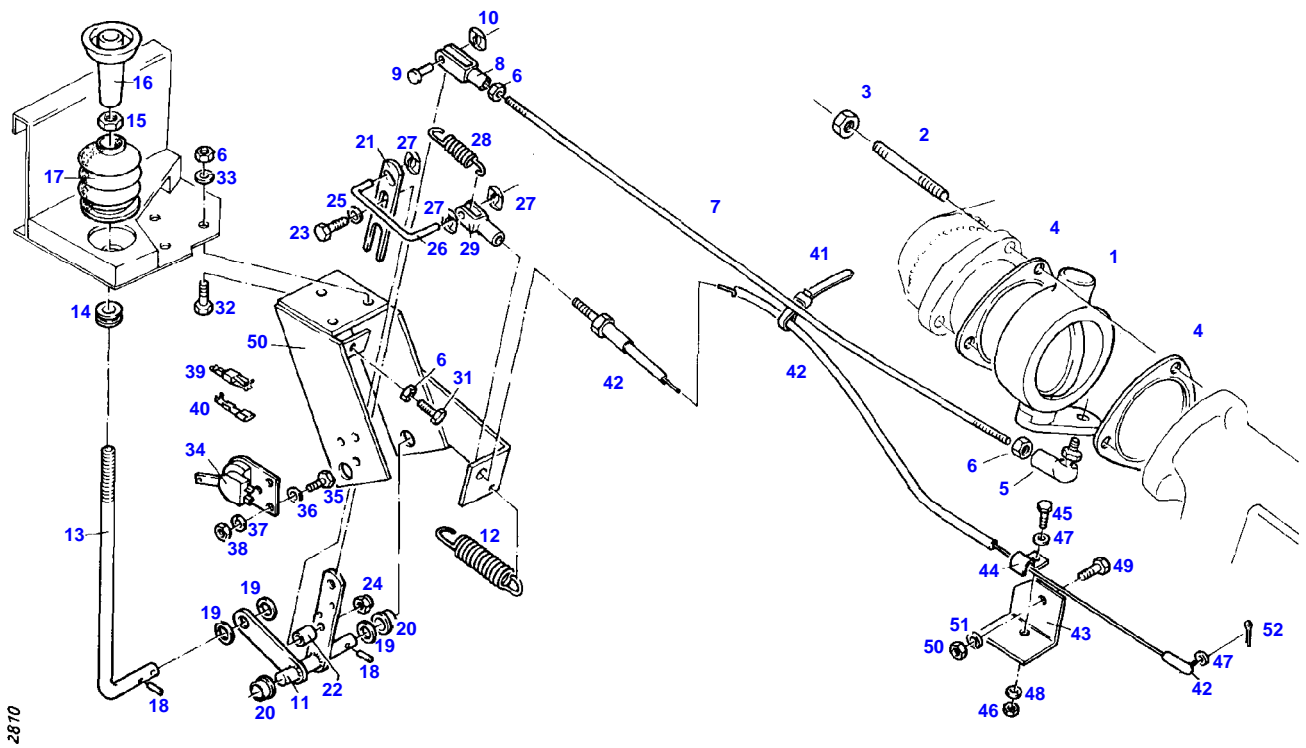

Item	Part Number	Qty	Description Comments	Technical Specification
			ENGINE STOP <-- 281/2848	
1	72350314	1	ENGINE BRAKE <>	
	72409386	1	ROD	
2	72374632	3	STUD BOLT	DIN 939 M8X55-8.8
3	72313269	3	NUT	DIN 934 M8-8C2A
4	72407298	1	MOLDED SEAL	
5	72316304	1	BALL SOCKET <>	DIN 71805 B13-A3L
	72317190	1	SECURING CLIP	DIN71805 S13-A3L
6	72313268	6	NUT	DIN 934 M8-8A3L
7	72404958	1	ROD	
8	72311309	1	CLEVIS	DIN 71752 G8X32-A3L
9	72310436	1	BOLT	DIN 1434 8H11X22X17,5-UST36-2
10	72311180	1	DUO-CLIP	8 SXN10
11				
			NO LONGER AVAILABLE	
12	72316493	1	PULLING SPRING	
13	72405876	1	ROD	
14	72310698	1	UNIVERSAL SPOUT	
15	72313295	1	NUT	DIN 936 M12-17H A3L
16	72393101	1	PUSH BUTTON	
17	72377267	1	BELLOWS	
18	72375132	3	TENSIONING PIN	ISO8752-4X18-A-ST-ZNPHR10F-KOE
19	72311804	3	DISC	DIN 433-13-ST.A3L
20	72393653	2	BUSH	
21	72405878	1	PLATE LINK	
22	72316967	1	SPACER TUBE	
23	72315635	1	HEXAGONAL HEAD BOLT	DIN 933 M6X35-8.8A3L
24	72313318	1	NUT	DIN6925-M6-8-A3L
25	72311787	1	DISC	DIN 125-6,4-ST.A3L
26	72405877	1	ROD	
27	72311178	3	DUO-CLIP	5 SXN10
28	72316492	1	PULLING SPRING	
29	72311305	1	CLEVIS	DIN 71752 G5X10-A3L
30	72362532	1	HOUSING	
31	72315657	1	HEXAGONAL HEAD BOLT	DIN 933 M8 X 30-8.8A3L
32	72315650	3	HEXAGONAL HEAD BOLT	DIN 933 M8 X 20-8.8A3L
33	72315053	3	SPLIT WASHER	FWN 65208-8-A3L
34	72380878	1	STOP LIGHT ROTATING SWITCH	
35	72315619	3	HEXAGONAL HEAD BOLT	DIN 933 M5X16-8.8A3L
36	72311785	3	DISC	DIN 125-5,3-ST.A3L
37	72315051	3	SPLIT WASHER	FWN 65208-5-A3L
38	72313264	3	NUT	DIN 934 M5-8A3L
39	72311363	1	TIMER CONTACT	
	72314686	2	PLUG IN SLEEVE NOT ILLUSTRATED	
41	72316916	9	CABLE STRAP	FWN 66650 B175X4-SW
42	72362531	1	BOWDEN CABLE ENGINE BRAKE	
43	72404902	1	ANGLE ENGINE BRAKE	
44				
			NO LONGER AVAILABLE	
45	72315626	1	HEXAGONAL HEAD BOLT ENGINE BRAKE	DIN 933-M6 X 16-8.8-A3L
46	72313266	1	NUT ENGINE BRAKE	DIN 934 M6-8A3L
47	72311787	2	DISC ENGINE BRAKE	DIN 125-6,4-ST.A3L
48	72315052	1	SPLIT WASHER ENGINE BRAKE	FWN 65208-6-A3L

Item	Part Number	Qty	Description Comments	Technical Specification
49	72315653	1	HEXAGONAL HEAD BOLT ENGINE BRAKE	DIN 933 M8 X 25-8.8A3L
50	72313268	1	NUT ENGINE BRAKE	DIN 934 M8-8A3L
51	72315053	1	SPLIT WASHER ENGINE BRAKE	FWN 65208-8-A3L
52	72313873	1	COTTER ENGINE BRAKE	DIN 94-2X12-ST.A3L

FAVORIT 610 (281/00001-99999)
342

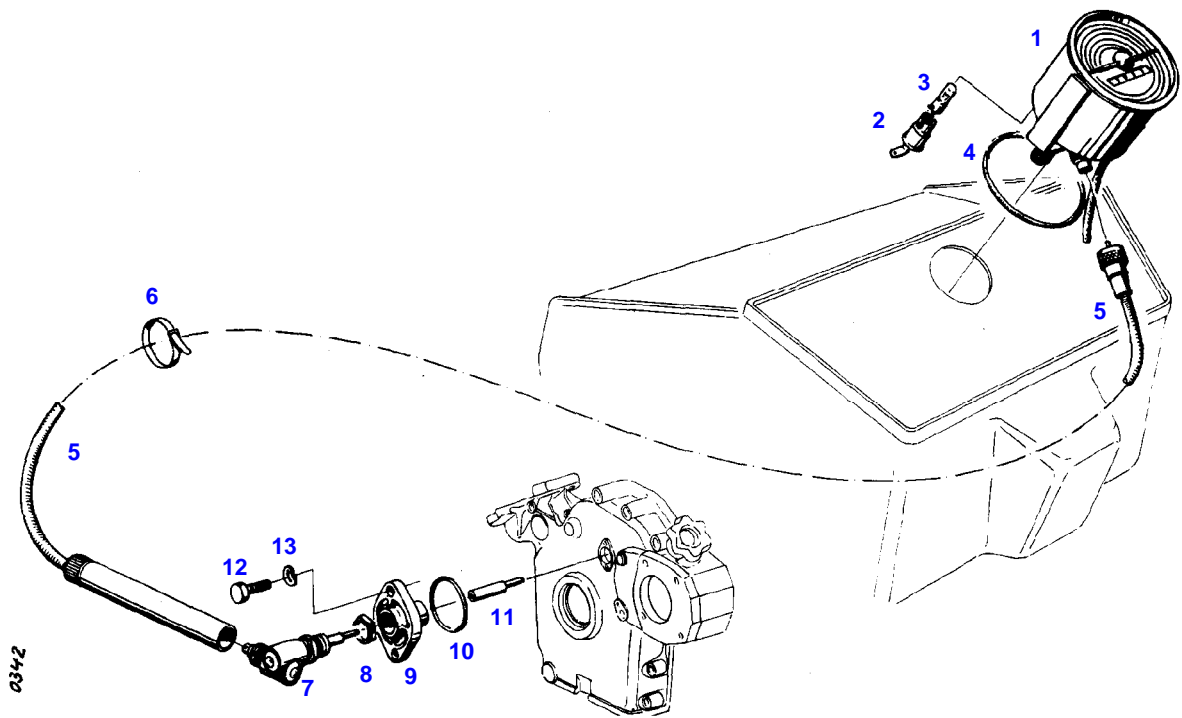

Item	Part Number	Qty	Description Comments	Technical Specification
1	72379822	1	TRACTOMETER ><1-4 25KM + 30KM	100
	72379826	1	TRACTOMETER ><1-4 40KM	100
2	72379814	1	LAMP SOCKET	
3	72334852	1	FILAMENT BULB	
4	72376658	1	O-RING	100X3-NBR 70 FWN56402
5	72605775	1	DRIVE SHAFT	
6	72316916	2	CABLE STRAP	FWN 66650 B175X4-SW
7	72334005	1	BEVEL GEAR SYSTEM	
8	72322566	1	NUT	
9	72335527	1	COVER	
10	72376544	1	O-RING	42,2X3-NBR 70 FWN56402
11	72327035	1	DRIVER	
12	72315650	2	HEXAGONAL HEAD BOLT	DIN 933 M8 X 20-8.8A3L
13	72317121	2	SPRING WASHER	DIN 137 B8-MECH.VZK

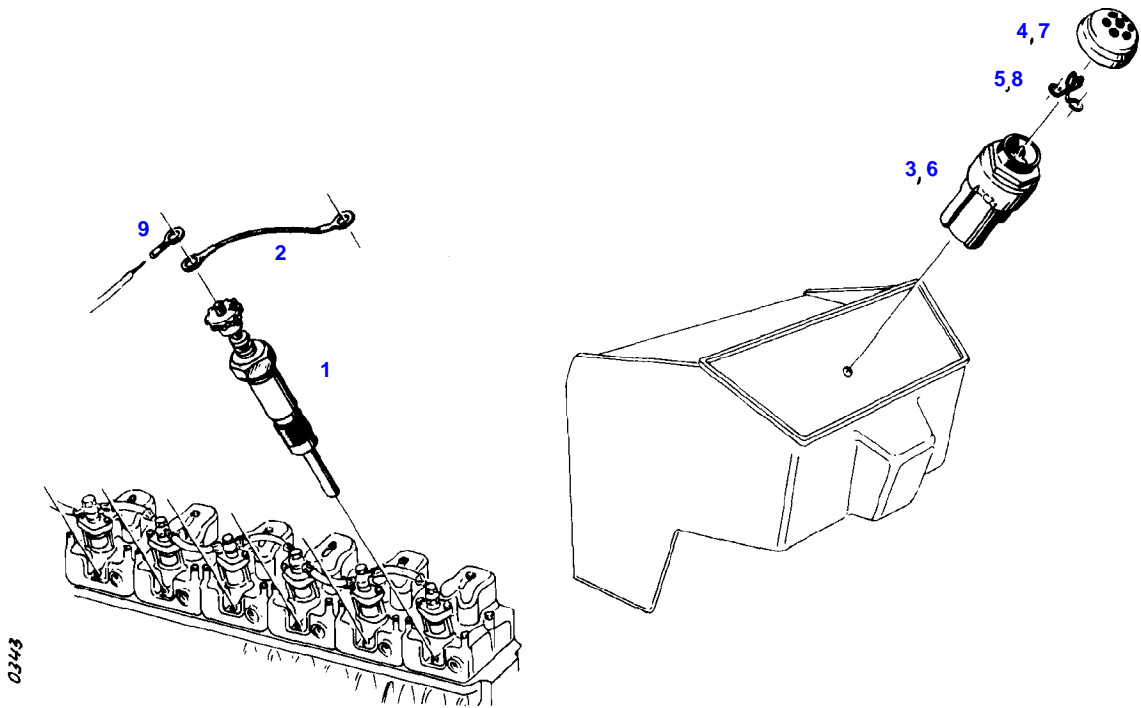

Item	Part Number	Qty	Description Comments
			--> 281/2619
1	72335281	6	ROD GLOW PLUG
2	72359162	5	CONNECTING CABLE
3	72331181	1	GLOW PLUG INDICATOR BERU ><4,5
4	72320692	1	SHIELD CAP
5	72331187	1	GLOW WIRE
6			NO LONGER AVAILABLE BOSCH ><7,8
7	72331189	1	SHIELD CAP
8	72331188	1	GLOW WIRE
9	72329002	1	CABLE LUG

FAVORIT 610 (281/00001-99999)
3064

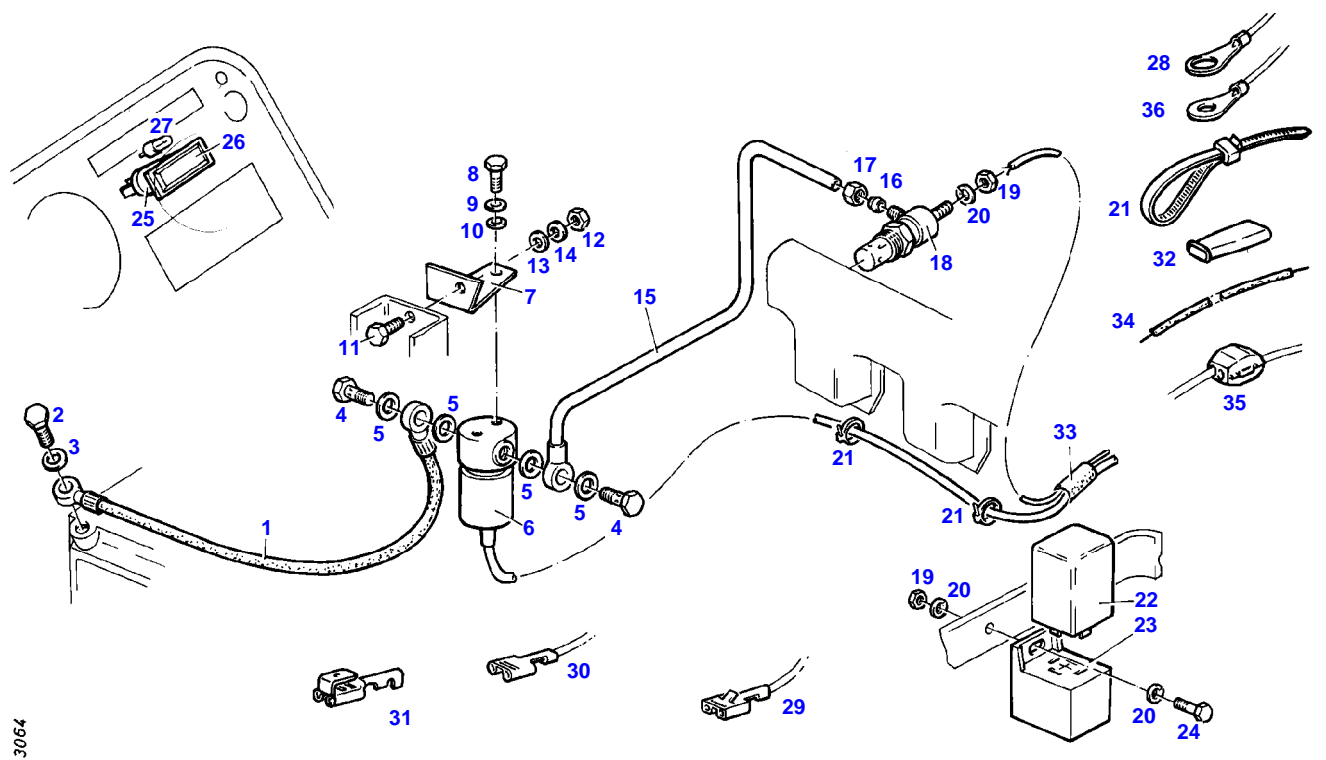

Item	Part Number	Qty	Description Comments	Technical Specification
			<-- 281/2620	
1	72362536	1	FUEL LINE	
2	72310187	1	DOUBLE BOLT	
3	72315094	1	SEALING WASHER	DIN 7603 A14X18-CU
4	72315806	2	BANJO BOLT	DIN 7643-6-3-A3L
5	72315088	4	SEALING WASHER	DIN 7603 A10X13,5-CU
6	72317090	1	VALVE SOLENOID	
7	72403257	1	MOUNTING ANGLE	
8	72315629	2	HEXAGONAL HEAD BOLT	DIN 933 M6 X 12-8.8A3L
9	72311787	2	DISC	DIN 125-6,4-ST.A3L
10	72315052	2	SPLIT WASHER	FWN 65208-6-A3L
11	72315646	1	HEXAGONAL HEAD BOLT	DIN 933 M8X18-8.8A3L
12	72313268	1	NUT	DIN 934 M8-8A3L
13	72311788	1	DISC	DIN 125-8,4-ST.A3L
14	72315053	1	SPLIT WASHER	FWN 65208-8-A3L
15	72362537	1	PIPE	
16	72377312	1	DOUBLE V-RING	DIN 3862-6-9SMNPB28K+G
17	72378005	1	CONNECTING NUT	DIN 3870 ALL6-9S20K A3L
18	72433489	1	ROD FLAME GLOW PLUG	
19	72313264	2	NUT	DIN 934 M5-8A3L
20	72317119	3	SPRING WASHER	DIN 137 B5-MECH.VZK
21	72316914	6	CABLE STRAP	FWN 66650 B100X2,5-SW
22	72428226	1	GLOW TIME RELAY	
23	72380994	1	PIN BASE	
24	72315619	1	HEXAGONAL HEAD BOLT	DIN 933 M5X16-8.8A3L
25	72380753	1	PILOT LAMP	
26			NO LONGER AVAILABLE	
27	72380412	1	FILAMENT BULB	DIN 72601-H-12V2W
28	72333918	3	CABLE LUG	
29	72314785	2	PLUG IN SLEEVE	
30	72314686	5	PLUG IN SLEEVE	
31	72331193	1	PLUG IN SLEEVE	
32	72316070	1	BUSHING INSULATOR	
33	72450804	1	INSULATING TUBING CUT TO LENGTH	L=2800DIN 40621 B8X0,7-S
34			NO LONGER AVAILABLE	
35	72379227	1	CABLE CONNECTOR	
36	72333502	1	CABLE LUG	

FAVORIT 610 (281/00001-99999)
323

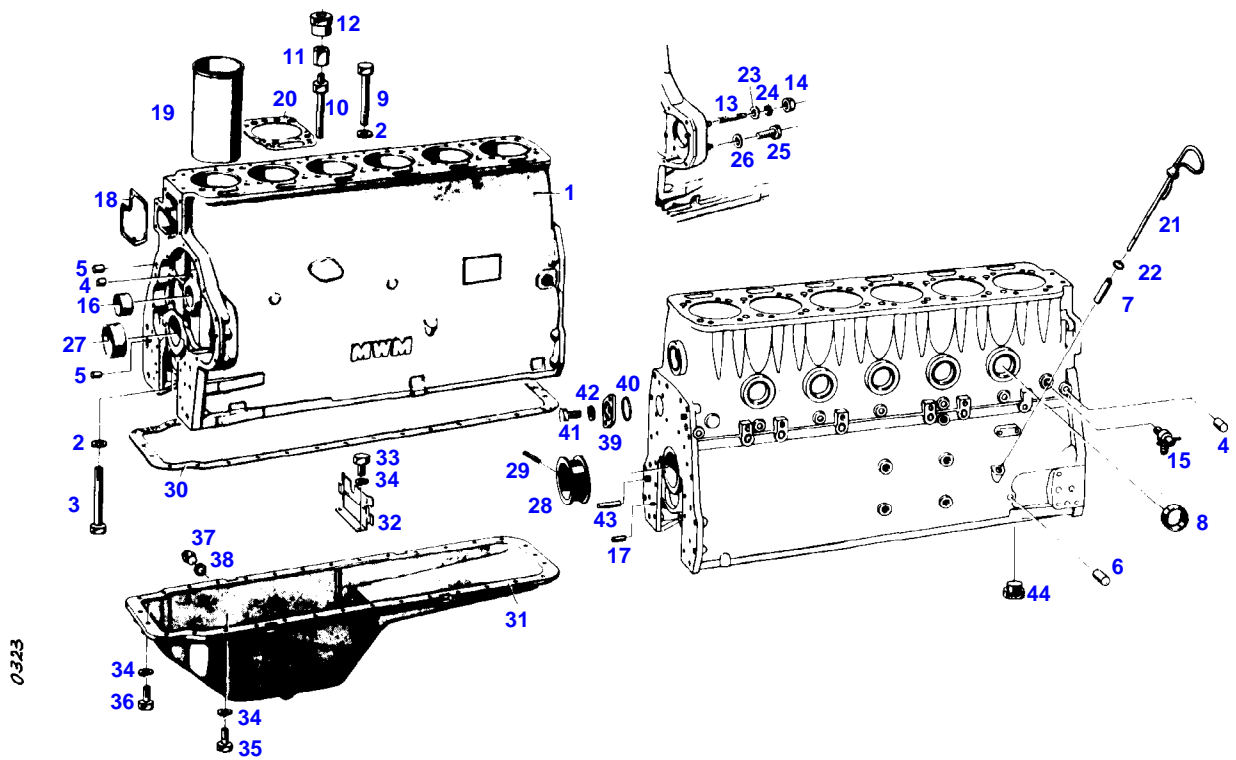

0323

Item	Part Number	Qty	Description Comments	Technical Specification
1	72331759	1	CRANKCASE ><1-10,12,15,16,19,28,29,32,44 --> 281/0724	
	72340144	1	CRANKCASE ><1-6,8,15,16,19,44 <-- 281/0725 --> 281/0949 <-- 281/0954 --> 281/0954	
	72340168	1	CRANKCASE ><1-6,8,15,16,44 <-- 281/0950 --> 281/0953 <-- 281/0955	
	72334873	2	PLUG --> 281/0724 NOT ILLUSTRATED	
2	72324592	38	DISC	
3	72327081	14	HEXAGONAL HEAD BOLT	
4	72327772	9	PLUG	
5	72327773	3	PLUG	
6	72327068	2	PLUG	
7	72326139	1	PIPE PIECE ENG.NO. --> 227.6.2.04769 <> <>	
	72343547	1	DIPSTICK	
8	72377226	6	COVER 50 MM	DIN 443-50
	72377227	6	COVER 52 MM	DIN 443-52
9	72326267	21	HEXAGONAL HEAD BOLT	
10	72326268	3	HEXAGONAL HEAD BOLT	
11	72419370	3	NUT	
12	72331775	1	NUT --> 281/0724	
13	72313777	4	STUD BOLT	DIN 939 M10X35-8.8
14	72372811	4	NUT	DIN 934 M10-10A3L
15	72378063	1	RELIEF VALVE	DIN71401-CM14X1,5KEG
16	72330749	1	BUSH	
17	72313859	4	CYLINDER PIN	DIN 7-8M6X18-ST50K
18	72327043	1	MOLDED SEAL	
19	72331774	6	CYLINDER LINER HONED AFTER MOUNTING --> 281/0949 <-- 281/0954 --> 281/0954	
	72331777	6	CYLINDER LINER FINISHED SIZE --> 281/0949 <-- 281/0954 --> 281/0954	
	72331778	6	CYLINDER LINER FINISHED SIZE HIGH TIN COLLAR --> 281/0949 <-- 281/0954 --> 281/0954	
	72340169	6	CYLINDER LINER <-- 281/0950 --> 281/0953 <-- 281/0955	
	72340170	12	SEAL <-- 281/0950 --> 281/0953 <-- 281/0955 NOT ILLUSTRATED	
20	72331766	6	CYLINDER HEAD GASKET --> 281/0724	
	72326269	6	CYLINDER HEAD GASKET 1,4 MM <-- 281/0725 --> 281/0949 <-- 281/0954 --> 281/0954	

Thank you so much for reading.
Please click the “Buy Now!”
button below to download the
complete manual.



After you pay.

You can download the most
perfect and complete manual in
the world immediately.

Our support email:

ebooklibonline@outlook.com