

<b>Page Number</b>	<b>Page Title</b>	<b>Page Reference</b>
01-000-TOC	ENGINE, FUEL AND EXHAUST SYSTEM	01-000-TOC
02-000-TOC	AXLES	02-000-TOC
03-000-TOC	STEERING SYSTEM	03-000-TOC
04-000-TOC	DRIVE TRAIN SYSTEM	04-000-TOC
05-000-TOC	COMPRESSED AIR SYSTEM	05-000-TOC
06-000-TOC	HYDRAULIC SYSTEM	06-000-TOC
07-000-TOC	ELECTRICAL SYSTEM	07-000-TOC
08-000-TOC	CAB	08-000-TOC
09-000-TOC	AIR CONDITIONING AND HEATING SYSTEM	09-000-TOC
10-000-TOC	CHASSIS	10-000-TOC
11-000-TOC	WHEELS	11-000-TOC
12-000-TOC	IMPLEMENT LIFT SYSTEM FRONT	12-000-TOC
13-000-TOC	IMPLEMENT LIFT SYSTEM REAR	13-000-TOC
14-000-TOC	FRONT/REAR LOADERS	14-000-TOC
15-000-TOC	ACCESSORIES	15-000-TOC

FAVORIT 615 (285/00001-99999)  
3007

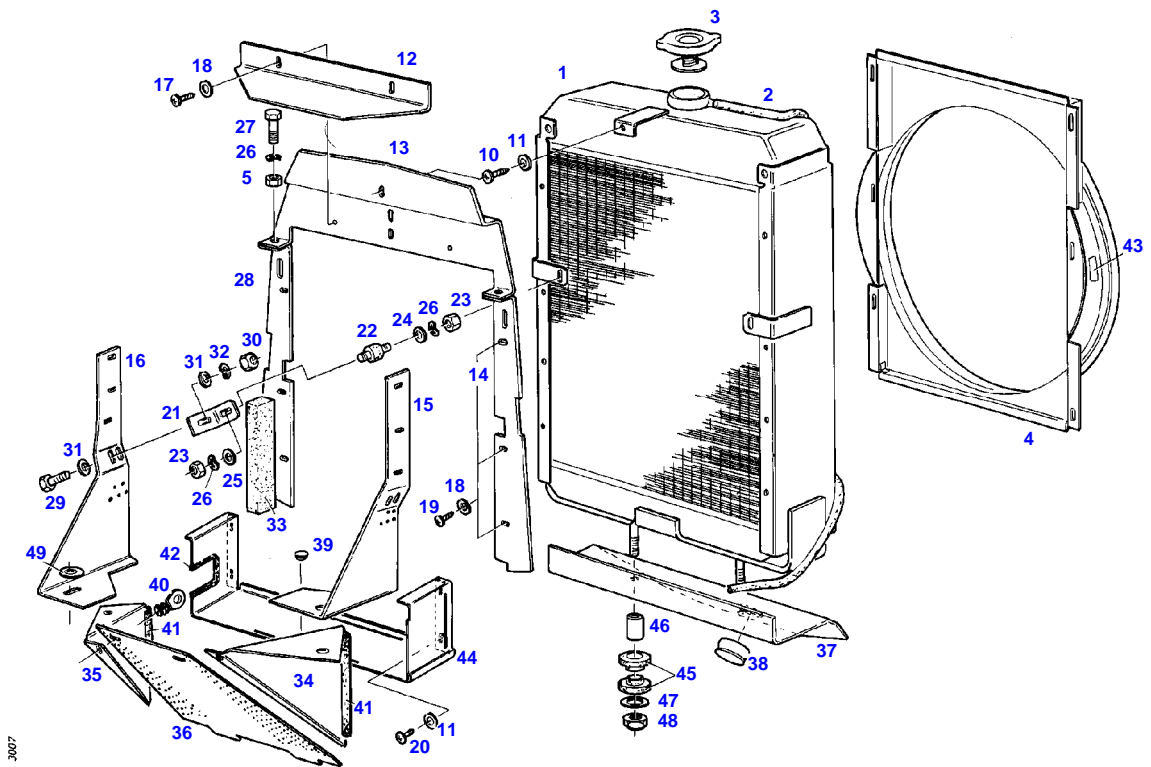

Item	Part Number	Qty	Description Comments	Technical Specification
			<b>WITH AIR CONDITIONING</b> <b>&lt;-- 285/0800</b>	
1	72471948	1	NO LONGER AVAILABLE ><2-5	
2	72436028	1	HOSE	L=1500FWN65912-10X2-PVC-W-G
3	72340925	1	COLLER LOCKING	
4	72362535	1	FAN HOOD	
5	72313266	2	NUT	DIN 934 M6-8A3L
10	72374969	1	SCREW	DIN7976-ST4,8X19-C-A3L
11	72311785	5	DISC	DIN 125-5,3-ST.A3L
12	72405891	1	COVER PANEL	
13	72404928	1	SPLASH PANEL	
14	72404914	1	BARRIER WALL	
15	72405884	1	RETAINER LEFT	
16	72405885	1	RETAINER RIGHT	
17	72315812	2	SCREW	DIN 7981 ST4,2X9,5-F-H-A3
18	72311817	8	DISC	DIN9021-4,3-140HV-A3L
19	72315781	6	SCREW	DIN 7981 ST3,5X9,5-C-H-A3
20	72374968	4	SCREW	DIN7976-ST4,8X9,5-C-A3L
21	72405776	2	ANGLE	
22	72310623	2	BUFFER	
23	72313266	4	NUT	DIN 934 M6-8A3L
24	72311822	2	DISC	DIN9021-6,4-140HV-A3L
25	72311787	2	DISC	DIN 125-6,4-ST.A3L
26	72317120	6	SPRING WASHER	DIN 137 B6-MECH.VZK
27	72315629	2	HEXAGONAL HEAD BOLT	DIN 933 M6 X 12-8.8A3L
28	72404915	1	BARRIER WALL	
29	72315650	2	HEXAGONAL HEAD BOLT	DIN 933 M8 X 20-8.8A3L
30	72313268	2	NUT	DIN 934 M8-8A3L
31	72311788	4	DISC	DIN 125-8,4-ST.A3L
32	72317121	2	SPRING WASHER	DIN 137 B8-MECH.VZK
33			NO LONGER AVAILABLE	
34	72405887	1	GUSSET PLATE LEFT	
35	72405890	1	GUSSET PLATE RIGHT	
36	72405892	1	FLOOR SHEET	
37			NO LONGER AVAILABLE	
38	72375084	1	LOCKING PLUG F35	SW-F35
39	72426777	1	LOCKING PLUG F5	F5
40	72334276	2	CATCH	
41	72450971	1	SHAPED CORD 1X 170 MM CUT TO LENGTH	L=1000 FWN 63040 C02
42	72451141	1	PROTECTIVE STRIP 1X 120 MM CUT TO LENGTH	L=800 FWN 63040
43	72379109	2	MARKING PLATE	FWN66556-35X68-SCHUTZVORR.N.OE
44	72364553	1	FRAME	
45	72311639	4	RADIATOR DAMPER	
46	72310742	2	BUSH	
47	72311849	2	DISC	
48	72313327	2	NUT	DIN 980-VM14-8-A3L
49	72311793	2	DISC	DIN 125-17-ST.A3L

FAVORIT 615 (285/00001-99999)  
1248

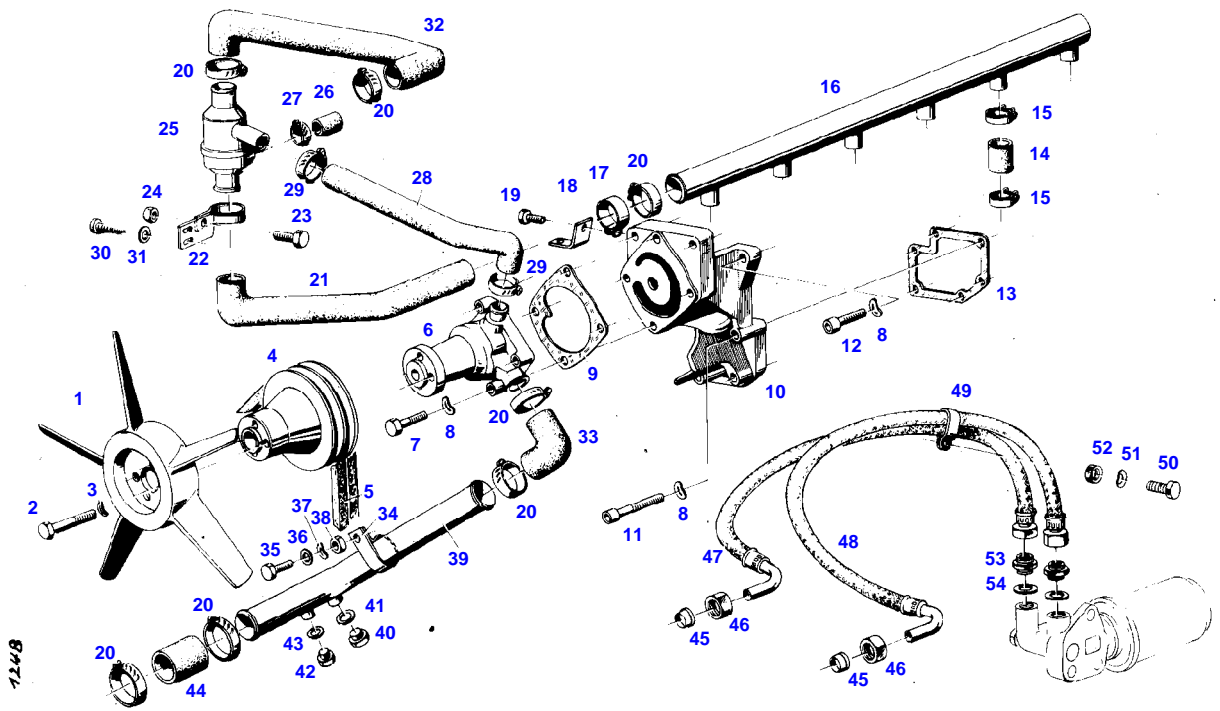

Item	Part Number	Qty	Description Comments	Technical Specification
			CENTRIFUGAL PUMP PIPE WITHOUT AIR CONDITION --> 285/0581	
1	72331543	1	FAN <>	
	72394835	4	DISC	
2	72315673	4	HEXAGONAL HEAD BOLT	DIN 933 M8X75-8.8A3L
	72394835	4	DISC NOT ILLUSTRATED	
3	72317121	4	SPRING WASHER	DIN 137 B8-MECH.VZK
4	72405861	1	V BELT SHEAVE	
	72405864	1	V BELT SHEAVE TROPICAL VERSION	
5			SEE ALTERNATOR ASSY	
6	72340133	1	CENTRIFUGAL PUMP	
	72340137	1	FACE SEAL NOT ILLUSTRATED	
	72340139	1	COUNTER RING NOT ILLUSTRATED	
	72340140	1	IMPELLER NOT ILLUSTRATED	
7	72315659	4	HEXAGONAL HEAD BOLT	DIN 933 M8X35-8.8
8	72315053	10	SPLIT WASHER	FWN 65208-8-A3L
9	72328678	1	SEAL	
10	72340134	1	INTERMEDIATE PIECE	
11	72315484	4	SOCKET HEAD BOLT	DIN 912 M8X65-10.9A3L
12	72315476	2	SOCKET HEAD BOLT	DIN 912 M8X30-10.9
13			SEE CRANKCASE	
14	72450415	1	HOSE 1X 30MM	L=900 DIN73411-22X3,5 R
15	72311167	12	HOSE CLIP	
16	72341138	1	PRESSURE LINE	
17	72337051	2	PIPE CLAMP	
18			NO LONGER AVAILABLE --> 285/0116	
	72326283	1	GUSSET PLATE <-- 285/0117	
19	72315629	2	HEXAGONAL HEAD BOLT --> 285/0116	DIN 933 M6 X 12-8.8A3L
	72315630	2	HEXAGONAL HEAD BOLT <-- 285/0117	DIN 933 M6X18-8.8A3L
20	72311162	7	HOSE CLIP	
21	72404920	1	RUBBER ARCH	
	72404929	1	CLAMP NOT ILLUSTRATED	
	72315626	1	HEXAGONAL HEAD BOLT NOT ILLUSTRATED	DIN 933-M6 X 16-8.8-A3L
	72315052	1	SPLIT WASHER NOT ILLUSTRATED	FWN 65208-6-A3L
	72313266	1	NUT NOT ILLUSTRATED	DIN 934 M6-8A3L
22	72362035	1	RETAINER --> 285/0100 <> <>	
	72311162	1	HOSE CLIP	
	72311171	1	HOSE CLIP	
	72315789	2	SCREW	DIN 7981 ST4,8X9,5-C-H-A3
	72311171	1	HOSE CLIP <-- 285/0101 NOT ILLUSTRATED	

Item	Part Number	Qty	Description Comments	Technical Specification
	72311162	1	HOSE CLIP <-- 285/0101 NOT ILLUSTRATED	
23	72315650	1	HEXAGONAL HEAD BOLT --> 285/0100	DIN 933 M8 X 20-8.8A3L
24	72313268	1	NUT --> 285/0100	DIN 934 M8-8A3L
25	72380194	1	THERMOSTAT	
26	72404925	1	CAP NOT NEEDED WITH HEATING	
27	72311167	1	HOSE CLIP NOT NEEDED WITH HEATING	
28	72404921	1	RUBBER ARCH	
29	72311167	2	HOSE CLIP	
30	72315781	2	SCREW --> 285/0100	DIN 7981 ST3,5X9,5-C-H-A3
	72315789	2	SCREW <-- 285/0101	DIN 7981 ST4,8X9,5-C-H-A3
	72311787	2	DISC TROPICAL VERSION NOT ILLUSTRATED	DIN 125-6,4-ST.A3L
31	72311817	2	DISC --> 285/0100	DIN9021-4,3-140HV-A3L
	72311787	2	DISC <-- 285/0101	DIN 125-6,4-ST.A3L
32	72405866	1	RUBBER ARCH	
33	72399873	1	RUBBER ARCH	
34	72394567	1	FASTENING COLLAR	
35	72315631	1	HEXAGONAL HEAD BOLT	DIN 933 M6 X 20-8.8A3L
	72315636	1	HEXAGONAL HEAD BOLT --> 285/0523 TROPICAL VERSION	DIN 933 M6X40-8.8A3L
	72315631	1	HEXAGONAL HEAD BOLT <-- 285/0524 TROPICAL VERSION	DIN 933 M6 X 20-8.8A3L
36	72311822	1	DISC	DIN9021-6,4-140HV-A3L
37	72317120	1	SPRING WASHER	DIN 137 B6-MECH.VZK
38	72313266	1	NUT	DIN 934 M6-8A3L
39	72362033	1	SUCTION LINE HEATING	
	72362036	1	SUCTION LINE WITHOUT HEATING	
40	72315802	1	SCREW --> 285/0523 WITHOUT HEATING	DIN 7604 AM22X1,5-ST
41	72315101	1	SEALING WASHER --> 285/0523 WITHOUT HEATING	DIN 7603 A22X27-CU
42	72315799	1	PLUG	DIN 7604 AM14X1,5-A3L
43	72315094	1	SEALING WASHER	DIN 7603 A14X18-CU
44	72450416	1	HOSE 1X 60MM CUT TO LENGTH	L=120 DIN73411-35X
45	72315163	2	CUTTING RING	DIN 3861-L12-ST-A3L
46	72313366	2	CONNECTING NUT	DIN 3870 AL12-9S20K A3L
47	72362526	1	OIL LINE	
48	72356509	1	OIL LINE	
49			NO LONGER AVAILABLE	
50	72315629	1	HEXAGONAL HEAD BOLT	DIN 933 M6 X 12-8.8A3L
51	72317120	1	SPRING WASHER	DIN 137 B6-MECH.VZK
52	72313266	1	NUT	DIN 934 M6-8A3L
53	72393673	2	SCREW NECK	
54	72376031	2	SEALING WASHER	DIN 7603 A20X24-CU

FAVORIT 615 (285/00001-99999)  
2514

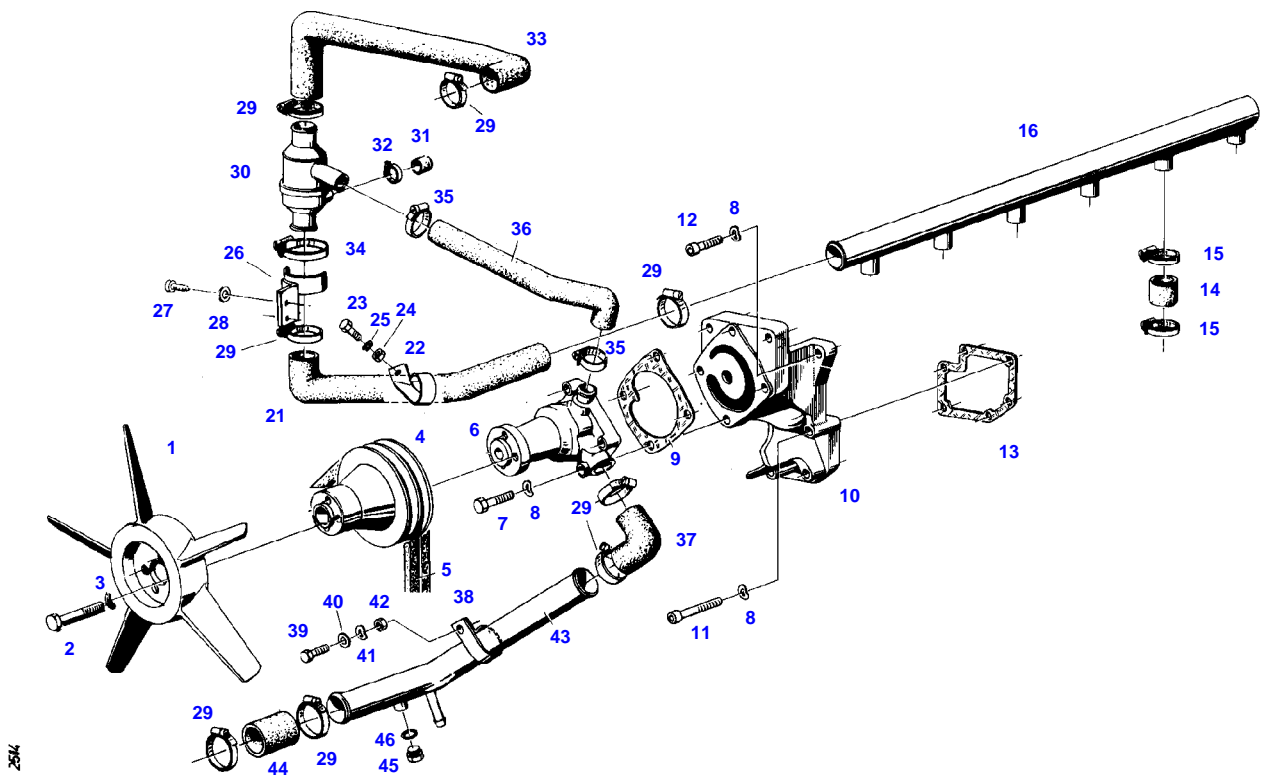

Item	Part Number	Qty	Description Comments	Technical Specification
			CENTRIFUGAL PUMP PIPE WITHOUT AIR CONDITION <-- 285/0582	
1	72331543	1	FAN <>	
	72394835	4	DISC	
	72380190	1	FAN TROPICAL VERSION	KST.
2	72315673	4	HEXAGONAL HEAD BOLT	DIN 933 M8X75-8.8A3L
	72394835	4	DISC NOT ILLUSTRATED	
3	72317121	4	SPRING WASHER	DIN 137 B8-MECH.VZK
	72311812	4	DISC NOT ILLUSTRATED TROPICAL VERSION	DIN 1440-8-ST.A3L
4	72405864	1	V BELT SHEAVE	
5			SEE ALTERNATOR ASSY	
6	72340133	1	CENTRIFUGAL PUMP	
	72340137	1	FACE SEAL NOT ILLUSTRATED	
	72340139	1	COUNTER RING NOT ILLUSTRATED	
	72340140	1	IMPELLER NOT ILLUSTRATED	
7	72315659	4	HEXAGONAL HEAD BOLT	DIN 933 M8X35-8.8
8	72315053	10	SPLIT WASHER	FWN 65208-8-A3L
9	72328678	1	SEAL	
10	72340134	1	INTERMEDIATE PIECE	
11	72315484	4	SOCKET HEAD BOLT	DIN 912 M8X65-10.9A3L
12	72315476	2	SOCKET HEAD BOLT	DIN 912 M8X30-10.9
13			SEE CRANKCASE	
14	72450415	1	HOSE 1X 30MM	L=900 DIN73411-22X3,5 R
15	72311167	12	HOSE CLIP	
16	72341138	1	PRESSURE LINE	
21	72404920	1	RUBBER ARCH	
22	72404929	1	CLAMP	
23	72315626	1	HEXAGONAL HEAD BOLT	DIN 933-M6 X 16-8.8-A3L
24	72313266	1	NUT	DIN 934 M6-8A3L
25	72315052	1	SPLIT WASHER	FWN 65208-6-A3L
26	72362035	1	RETAINER	
27	72315789	2	SCREW	DIN 7981 ST4,8X9,5-C-H-A3
28	72311787	2	DISC	DIN 125-6,4-ST.A3L
29	72311162	8	HOSE CLIP	
30	72380194	1	THERMOSTAT	
31	72404925	1	CAP NOT NEEDED WITH HEATING	
32	72311167	1	HOSE CLIP NOT NEEDED WITH HEATING	
33	72405866	1	RUBBER ARCH	
34	72311171	1	HOSE CLIP	
35	72311167	2	HOSE CLIP	
36	72404921	1	RUBBER ARCH	
37	72399873	1	RUBBER ARCH	
38	72394567	1	FASTENING COLLAR	
39	72315631	1	HEXAGONAL HEAD BOLT	DIN 933 M6 X 20-8.8A3L
40	72311822	1	DISC	DIN9021-6,4-140HV-A3L
41	72317120	1	SPRING WASHER	DIN 137 B6-MECH.VZK
42	72313266	1	NUT	DIN 934 M6-8A3L
43	72362033	1	SUCTION LINE HEATING	



Item	Part Number	Qty	Description Comments	Technical Specification
	72362036	1	SUCTION LINE WITHOUT HEATING	
44	72450416	1	HOSE 1X 60MM CUT TO LENGTH	L=120 DIN73411-35X
45	72315799	1	PLUG	DIN 7604 AM14X1,5-A3L
46	72315094	1	SEALING WASHER	DIN 7603 A14X18-CU

FAVORIT 615 (285/00001-99999)  
3008

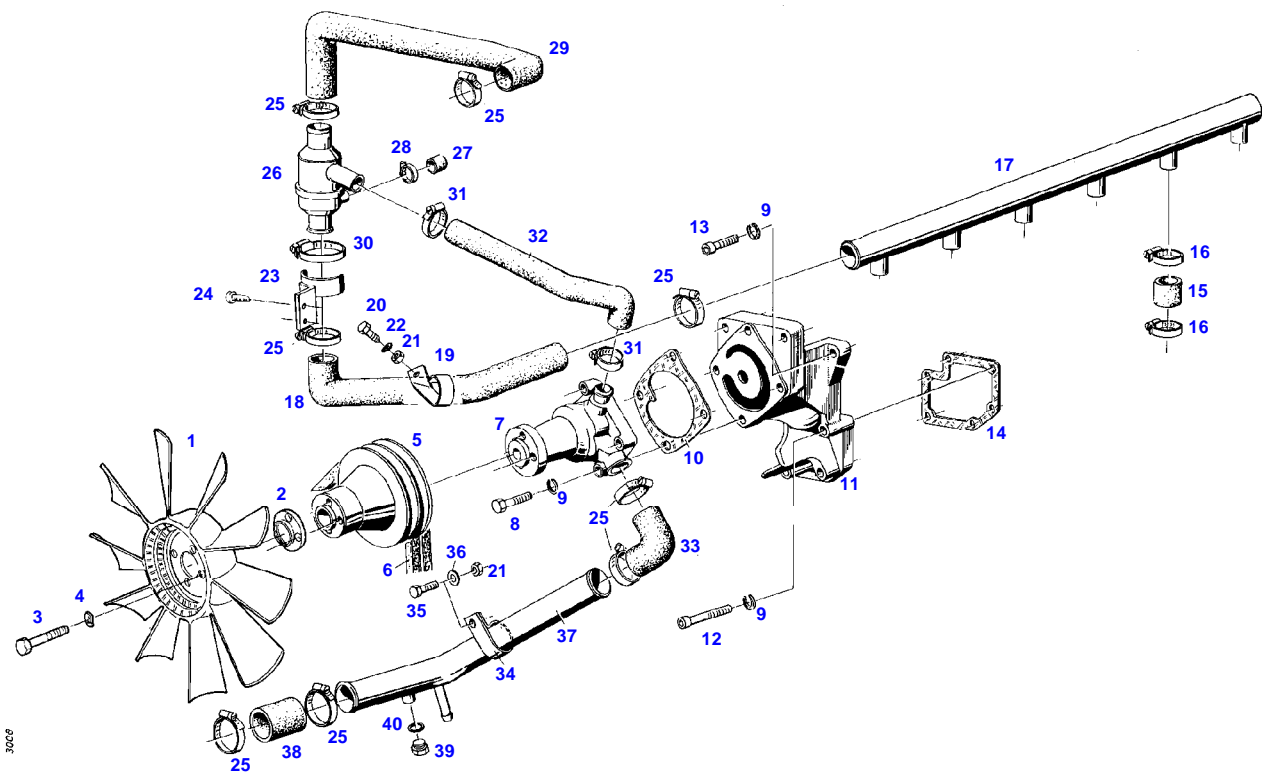

Item	Part Number	Qty	Description Comments	Technical Specification
			<b>CENTRIFUGAL PUMP PIPE WITH AIR CONDITIONING &lt;-- 285/0800</b>	
1	72380191	1	FAN <>	KST.
	72394835	4	DISC	
2	72405888	1	INTERMEDIATE RING	
3	72315673	4	HEXAGONAL HEAD BOLT	DIN 933 M8X75-8.8A3L
	72394835	4	DISC NOT ILLUSTRATED	
4	72317121	4	SPRING WASHER	DIN 137 B8-MECH.VZK
5	72405861	1	V BELT SHEAVE	
	72405864	1	V BELT SHEAVE TROPICAL VERSION	
6			SEE ALTERNATOR ASSY	
7	72340133	1	CENTRIFUGAL PUMP	
	72340137	1	FACE SEAL NOT ILLUSTRATED	
	72340139	1	COUNTER RING NOT ILLUSTRATED	
	72340140	1	IMPELLER NOT ILLUSTRATED	
8	72315659	4	HEXAGONAL HEAD BOLT	DIN 933 M8X35-8.8
9	72315053	10	SPLIT WASHER	FWN 65208-8-A3L
10	72328678	1	SEAL	
11	72340134	1	INTERMEDIATE PIECE	
12	72315484	4	SOCKET HEAD BOLT	DIN 912 M8X65-10.9A3L
13	72315476	2	SOCKET HEAD BOLT	DIN 912 M8X30-10.9
14			SEE CRANKCASE	
15	72450415	1	HOSE 1X 30MM	L=900 DIN73411-22X3,5 R
16	72311167	12	HOSE CLIP	
17	72341138	1	PRESSURE LINE	
18	72404920	1	RUBBER ARCH	
19	72404929	1	CLAMP	
20	72315626	1	HEXAGONAL HEAD BOLT	DIN 933-M6 X 16-8.8-A3L
21	72313266	1	NUT	DIN 934 M6-8A3L
22	72317120	1	SPRING WASHER	DIN 137 B6-MECH.VZK
23	72362035	1	RETAINER	
24	72374968	2	SCREW	DIN7976-ST4,8X9,5-C-A3L
25	72311162	8	HOSE CLIP	
26	72380194	1	THERMOSTAT	
27	72404925	1	CAP NOT NEEDED WITH HEATING	
28	72311167	1	HOSE CLIP NOT NEEDED WITH HEATING	
29	72405866	1	RUBBER ARCH	
30	72311171	1	HOSE CLIP	
31	72311167	2	HOSE CLIP	
32	72404921	1	RUBBER ARCH	
33	72399873	1	RUBBER ARCH	
34	72394567	1	FASTENING COLLAR	
35	72315631	1	HEXAGONAL HEAD BOLT	DIN 933 M6 X 20-8.8A3L
36	72311822	1	DISC	DIN9021-6,4-140HV-A3L
37	72362033	1	SUCTION LINE	
38	72450416	1	HOSE 1X 60MM CUT TO LENGTH	L=120 DIN73411-35X
39	72315799	1	PLUG	DIN 7604 AM14X1,5-A3L
40	72315094	1	SEALING WASHER	DIN 7603 A14X18-CU

FAVORIT 615 (285/00001-99999)  
2520

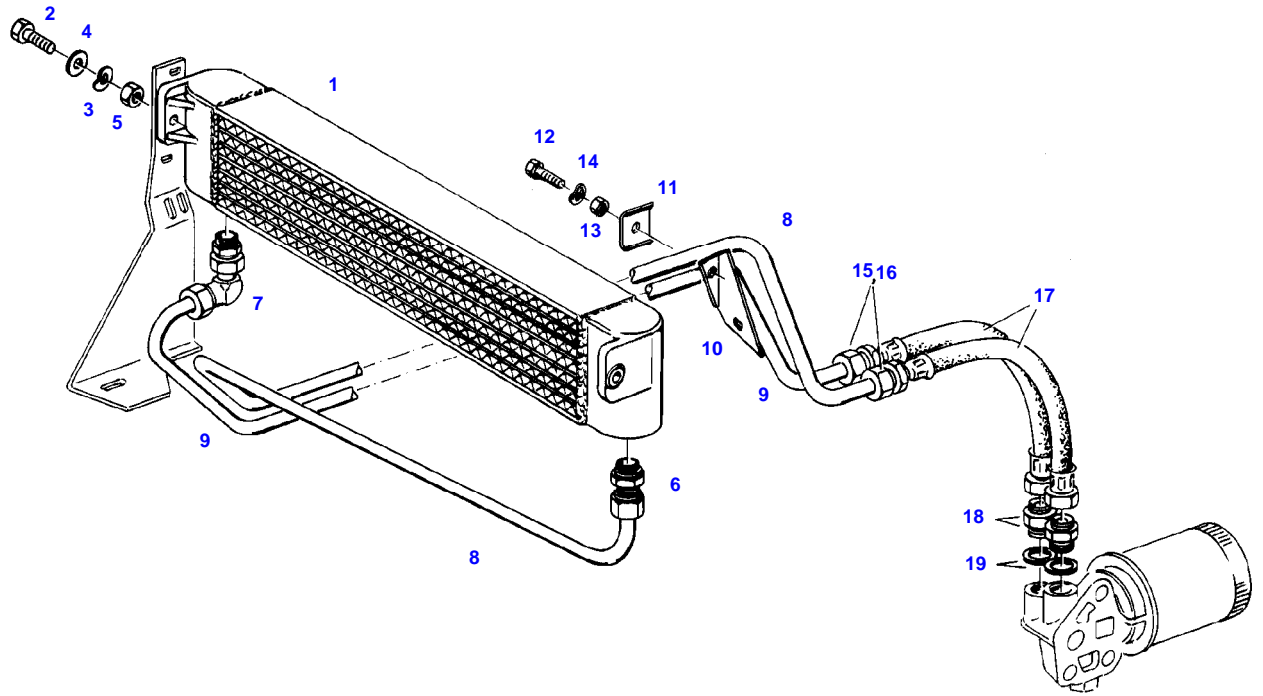

2520

Item	Part Number	Qty	Description Comments	Technical Specification
			<-- 285/0582	
1	72349803	1	OIL/AIR COOLER	
2	72315650	2	HEXAGONAL HEAD BOLT	DIN 933 M8 X 20-8.8A3L
3	72317121	2	SPRING WASHER	DIN 137 B8-MECH.VZK
4	72311788	2	DISC	DIN 125-8,4-ST.A3L
5	72313268	2	NUT	DIN 934 M8-8A3L
6	72316324	1	SCREW NECK	DIN 3901-L15B-M-ST-A3
	72315164	X	CUTTING RING	DIN 3861-L15-ST-A3L
	72313367	X	CONNECTING NUT	DIN3870 AL15/M22X1.5-9S20K A3L
7	72312097	1	ADJUSTABLE W-THREADED CONNECTION BODY	FWN65843-L15-A3L
	72316324	1	SCREW NECK	DIN 3901-L15B-M-ST-A3
	72315164	X	CUTTING RING	DIN 3861-L15-ST-A3L
	72313367	X	CONNECTING NUT	DIN3870 AL15/M22X1.5-9S20K A3L
8	72405998	1	PIPE	
			--> 285/0799	
	72405889	1	PIPE	
			<-- 285/0800	
9	72405997	1	PIPE	
10	72405996	1	RETAINER	
11	72311266	1	CLIP	
12	72315634	1	HEXAGONAL HEAD BOLT	DIN 933 M6X30-8.8A3L
13	72313266	1	NUT	DIN 934 M6-8A3L
14	72317120	1	SPRING WASHER	DIN 137 B6-MECH.VZK
15	72313367	2	CONNECTING NUT	DIN3870 AL15/M22X1.5-9S20K A3L
16	72315164	2	CUTTING RING	DIN 3861-L15-ST-A3L
17	72362590	2	OIL LINE	
18	72393673	2	SCREW NECK	
19	72376031	2	SEALING WASHER	DIN 7603 A20X24-CU

FAVORIT 615 (285/00001-99999)  
6084

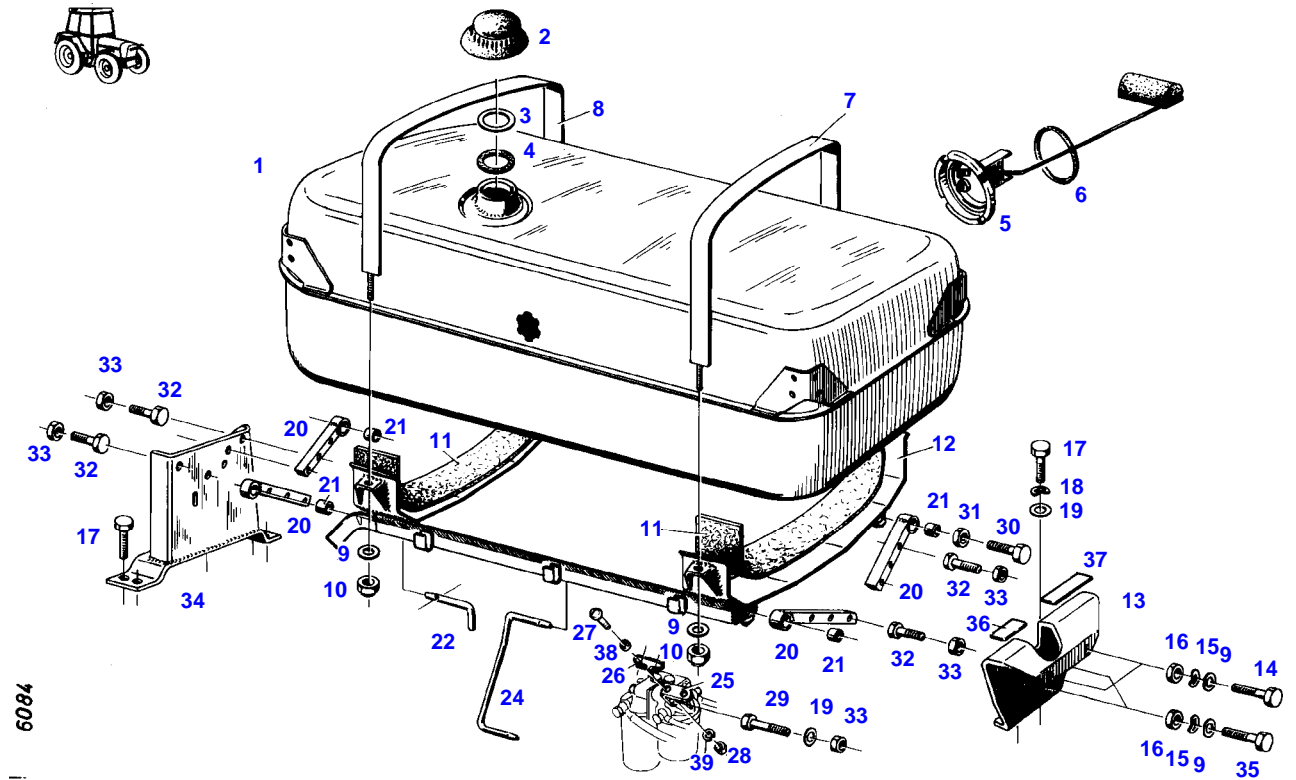

Item	Part Number	Qty	Description Comments	Technical Specification
1	72364691	1	FUEL TANK --> 285/0060 <> <>	
	72315802	1	SCREW	DIN 7604 AM22X1,5-ST
	72409020	1	REDUCER	
	72315104	1	SEALING WASHER	DIN 7603 A26X31-CU
	72350303	1	FUEL CAP	
	72315101	1	SEALING WASHER	DIN 7603 A22X27-CU
2	72380143	1	FUEL CAP ><3-4 --> 285/0060 <>	M.BELUEF
	72394572	1	PLASTIC CAP	
	72350303	1	FUEL CAP ><2-4 <-- 285/0061	
	72394572	1	PLASTIC CAP	
3	72330726	1	SEAL BLAU	
4	72330725	1	SEAL BLAU	
	72312304	1	RUBBER SEAL KOEHLER	
5	72613427	1	FUEL LEVEL SENSOR ><5+6	
6	72315169	1	SEALING WASHER	
7	72362041	1	BAND CLAMP	
8	72362042	1	BAND CLAMP	
9	72311788	8	DISC	DIN 125-8,4-ST.A3L
10	72313320	4	NUT	DIN6925-M8-8-A3L
11	72404934	2	FELT TAPE	
12	72364628	1	FRAME	
13	72409303	1	CONSOLE --> 285/0799 <> <>	
	72405619	1	COVER PANEL	
	72380203	1	FAN	
14	72315659	2	HEXAGONAL HEAD BOLT	DIN 933 M8X35-8.8
15	72315053	4	SPLIT WASHER	FWN 65208-8-A3L
16	72313268	4	NUT	DIN 934 M8-8A3L
17	72315678	7	HEXAGONAL HEAD BOLT	DIN 933 M10X20-8.8
18	72315054	2	SPLIT WASHER	FWN 65208-10-A3L
19	72311789	3	DISC	DIN 125-10,5-ST.A3L
20	72404942	4	SUPPORT ARM	
21	72310644	4	RUBBER BUSHING	
22	72397322	1	BEARING PIN	
	72311183	2	HAIR COTTER PIN NOT ILLUSTRATED	DIN 11024-4-A3L
24	72404936	1	BEARING PIN <>	
25	72404938	1	ANGLE	
26	72399331	1	RETAINER	
27	72315619	2	HEXAGONAL HEAD BOLT	DIN 933 M5X16-8.8A3L
28	72313264	2	NUT	DIN 934 M5-8A3L
29	72315700	1	HEXAGONAL HEAD BOLT --> 285/0186	DIN 933 M10X100-8.8
	72315685	1	HEXAGONAL HEAD BOLT <-- 285/0187	DIN 933 M10X30-8.8A3L
30	72374215	2	HEXAGONAL HEAD BOLT	DIN 931 M12X65-8.8
31	72313325	2	NUT	DIN 980-VM12-8-A3L
32	72315693	8	HEXAGONAL HEAD BOLT --> 285/0919	DIN 933 M10X45-8.8A3L
	72315693	7	HEXAGONAL HEAD BOLT <-- 285/0920	DIN 933 M10X45-8.8A3L
	72374898	1	SOCKET HEAD BOLT <-- 285/0920	DIN 6912-M10X45-8.8

<b>Item</b>	<b>Part Number</b>	<b>Qty</b>	<b>Description Comments</b>	<b>Technical Specification</b>
33	72313272	9	NUT	DIN 934 M10-8A3L
34	72364688	1	CONSOLE	
35	72315663	3	HEXAGONAL HEAD BOLT	DIN 933 M8X40-8.8A3L
36	72404939	1	BAND	
37	72404943	1	BAND	
38	72311818	2	DISC	DIN9021-5,3-140HV-A3L
39	72315051	2	SPLIT WASHER	FWN 65208-5-A3L



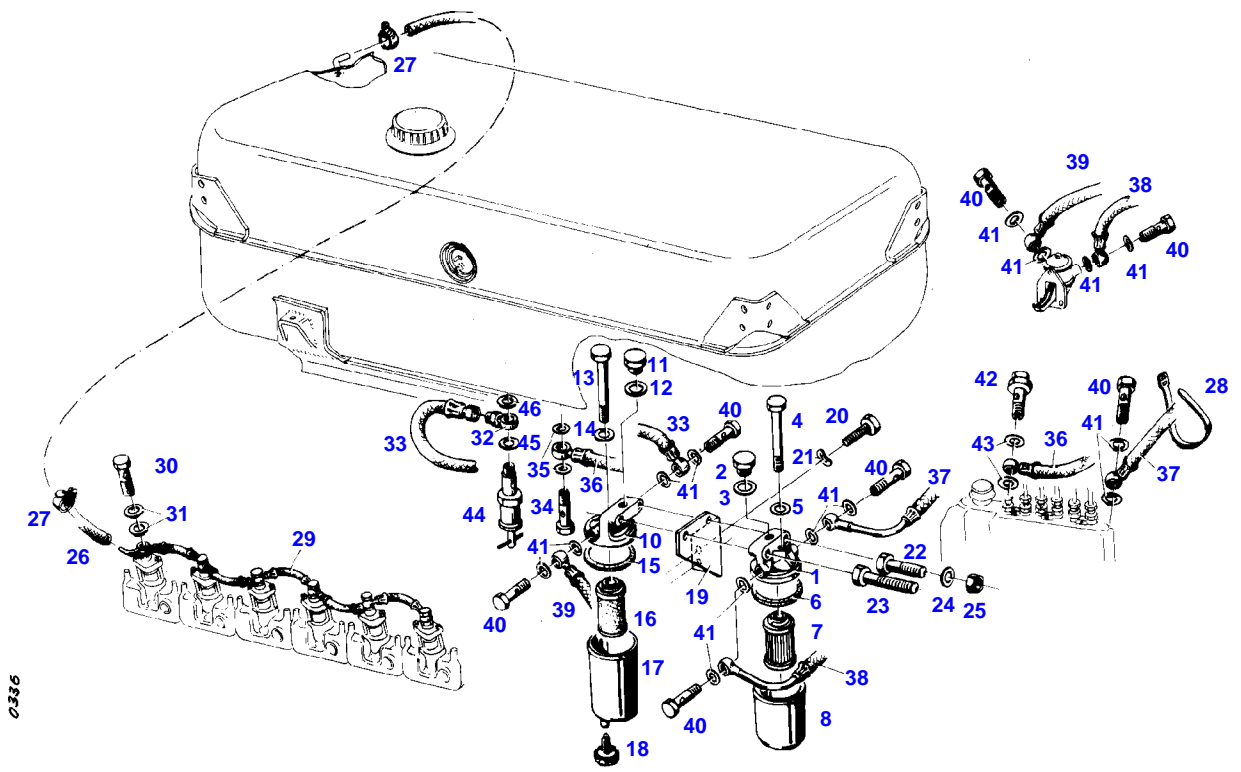

0336

Item	Part Number	Qty	Description Comments	Technical Specification
			<b>FUEL LINES</b> --> 285/0186	
1	72340109	1	FUEL FILTER ><2-8	
2	72340116	1	SCREW	
3	72315094	1	SEALING WASHER	DIN 7603 A14X18-CU
4	72315525	1	HEXAGONAL HEAD BOLT	DIN 931 M8 X 90-8.8A3L
5	72315086	1	SEALING WASHER	DIN 7603 A8X11,5-CU
6	72327233	1	SEAL	
7	72320177	1	FILTER BOX	
8				
			NOT AVAILABLE IN SINGLE PARTS	
10	72340111	1	FUEL FILTER ><11-18	
11	72340116	1	SCREW	
12	72315094	1	SEALING WASHER	DIN 7603 A14X18-CU
13	72315525	1	HEXAGONAL HEAD BOLT	DIN 931 M8 X 90-8.8A3L
14	72315086	1	SEALING WASHER	DIN 7603 A8X11,5-CU
15	72327233	1	SEAL	
16	72340113	1	FELT PIPE INSERT	
17				
			NOT AVAILABLE IN SINGLE PARTS	
18	72340115	1	DRAIN PLUG	
19	72404935	1	RETAINING BRACKET	
20	72315642	2	HEXAGONAL HEAD BOLT	DIN 933 M8 X 16-8.8A3L
21	72315053	2	SPLIT WASHER	FWN 65208-8-A3L
22	72374451	2	HEXAGONAL HEAD BOLT	DIN 933 M10X85-8.8
23				
			SEE FUEL TANK	
24	72311789	1	DISC	DIN 125-10,5-ST.A3L
25	72313272	1	NUT	DIN 934 M10-8A3L
26	72435830	1	PRESSURE HOSE 1390 MM CUT TO LENGTH	L=2100
27	72438345	2	HOSE CLIP	
28	72316916	3	CABLE STRAP	FWN 66650 B175X4-SW
29	72340112	1	LEAKAGE OIL LINE	
30	72315809	6	BANJO BOLT	DIN 7643-4-5-A3L
31	72315086	12	SEALING WASHER	DIN 7603 A8X11,5-CU
32	72377538	1	BANJO UNION	
33	72362043	1	FUEL LINE	
34	72315807	1	BANJO BOLT	DIN 7643-8-3-A3L
35	72315090	2	SEALING WASHER	DIN 7603 A12X15,5-CU
36	72364689	1	FUEL LINE	
37	72362045	1	FUEL LINE	
38	72362046	1	FUEL LINE	
39	72363812	1	FUEL LINE	
40	72315808	7	BANJO BOLT	DIN 7643-10-3-A3L
41	72315094	14	SEALING WASHER	DIN 7603 A14X18-CU
42	72380268	1	BLEED AND DRAIN VALVE	
43	72315095	2	SEALING WASHER	DIN 7603 A14X20-CU
44	72380161	1	FUEL SHUT-OFF VALVE	
45	72315099	1	SEALING WASHER	DIN 7603 A18X22-CU
46	72315098	1	SEALING WASHER	DIN 7603 A16X22-CU

FAVORIT 615 (285/00001-99999)  
39732

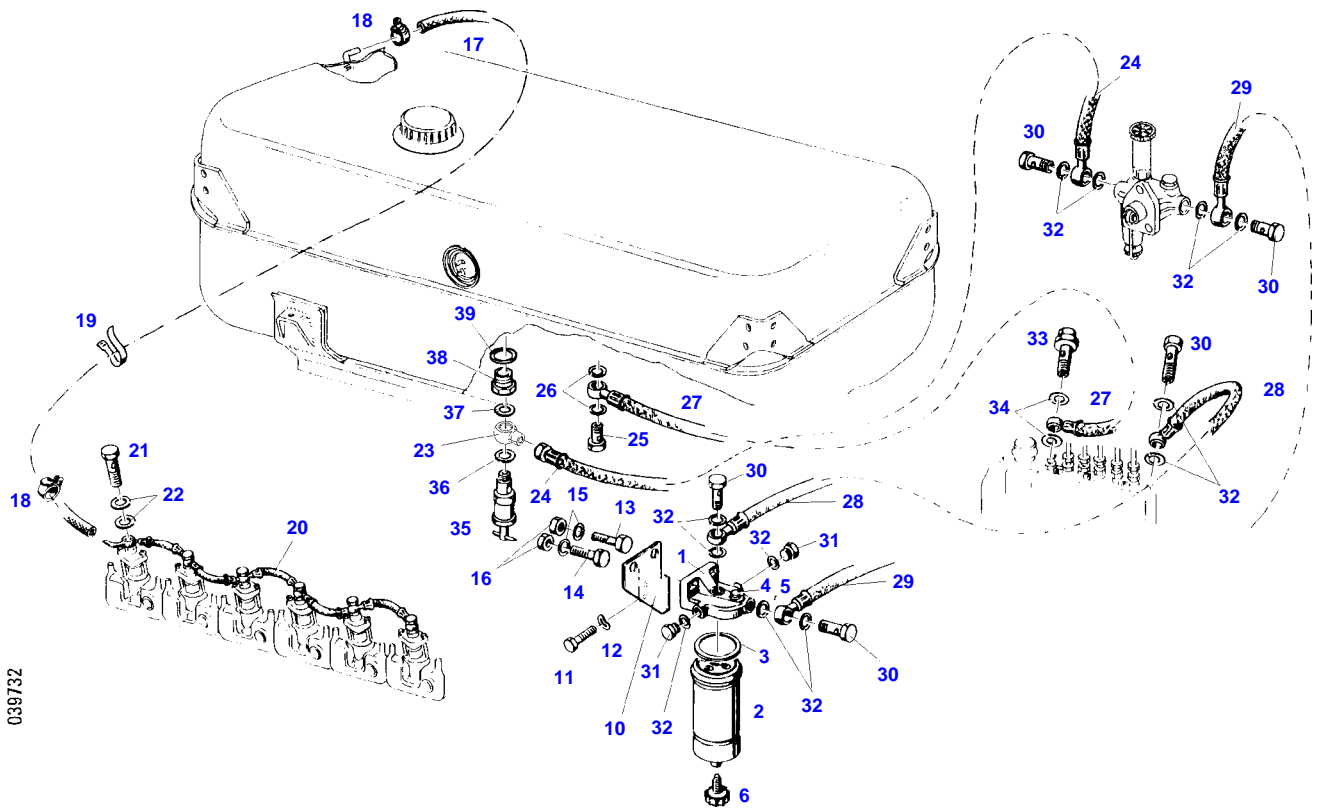

Item	Part Number	Qty	Description Comments	Technical Specification
			<b>FUEL LINES</b> <b>&lt;-- 285/0187</b>	
1	72350307	1	FUEL FILTER ><1-3	
2	72416928	1	FILTER BOX ><2+3	
3	72314995	1	RUBBER RING	
4	72323290	1	BLEED SCREW	
5	72315084	1	SEALING WASHER	DIN 7603 A6X10-CU
6	72330827	1	DRAIN SCREW	
10	72404935	1	RETAINING BRACKET	
11	72315642	2	HEXAGONAL HEAD BOLT	DIN 933 M8 X 16-8.8A3L
12	72315053	2	SPLIT WASHER	FWN 65208-8-A3L
13	72315685	1	HEXAGONAL HEAD BOLT	DIN 933 M10X30-8.8A3L
14			SEE FUEL TANK	
15	72311789	2	DISC	DIN 125-10,5-ST.A3L
16	72313272	2	NUT	DIN 934 M10-8A3L
17	72435830	1	PRESSURE HOSE 1390 MM CUT TO LENGTH	L=2100
18	72438345	2	HOSE CLIP	
19	72316916	3	CABLE STRAP	FWN 66650 B175X4-SW
20	72340112	1	LEAKAGE OIL LINE	
21	72315809	6	BANJO BOLT	DIN 7643-4-5-A3L
22	72315086	12	SEALING WASHER	DIN 7603 A8X11,5-CU
23	72377538	1	BANJO UNION	
24	72364540	1	FUEL LINE	
25	72315807	1	BANJO BOLT	DIN 7643-8-3-A3L
26	72315090	2	SEALING WASHER	DIN 7603 A12X15,5-CU
27	72364689	1	FUEL LINE	
28	72362049	1	FUEL LINE	
29	72362048	1	FUEL LINE	
30	72315808	5	BANJO BOLT	DIN 7643-10-3-A3L
31	72315799	2	PLUG	DIN 7604 AM14X1,5-A3L
32	72315094	12	SEALING WASHER	DIN 7603 A14X18-CU
33	72317103	1	BLEED AND DRAIN VALVE	
34	72315095	2	SEALING WASHER	DIN 7603 A14X20-CU
35	72380161	1	FUEL SHUT-OFF VALVE	
36	72315099	1	SEALING WASHER	DIN 7603 A18X22-CU
37	72315098	1	SEALING WASHER	DIN 7603 A16X22-CU
38	72409020	1	REDUCER	
39	72315104	1	SEALING WASHER	DIN 7603 A26X31-CU
40	72393682	1	MARKING PLATE ARABIAN-ENGLISH NOT ILLUSTRATED	

FAVORIT 615 (285/00001-99999)  
1249

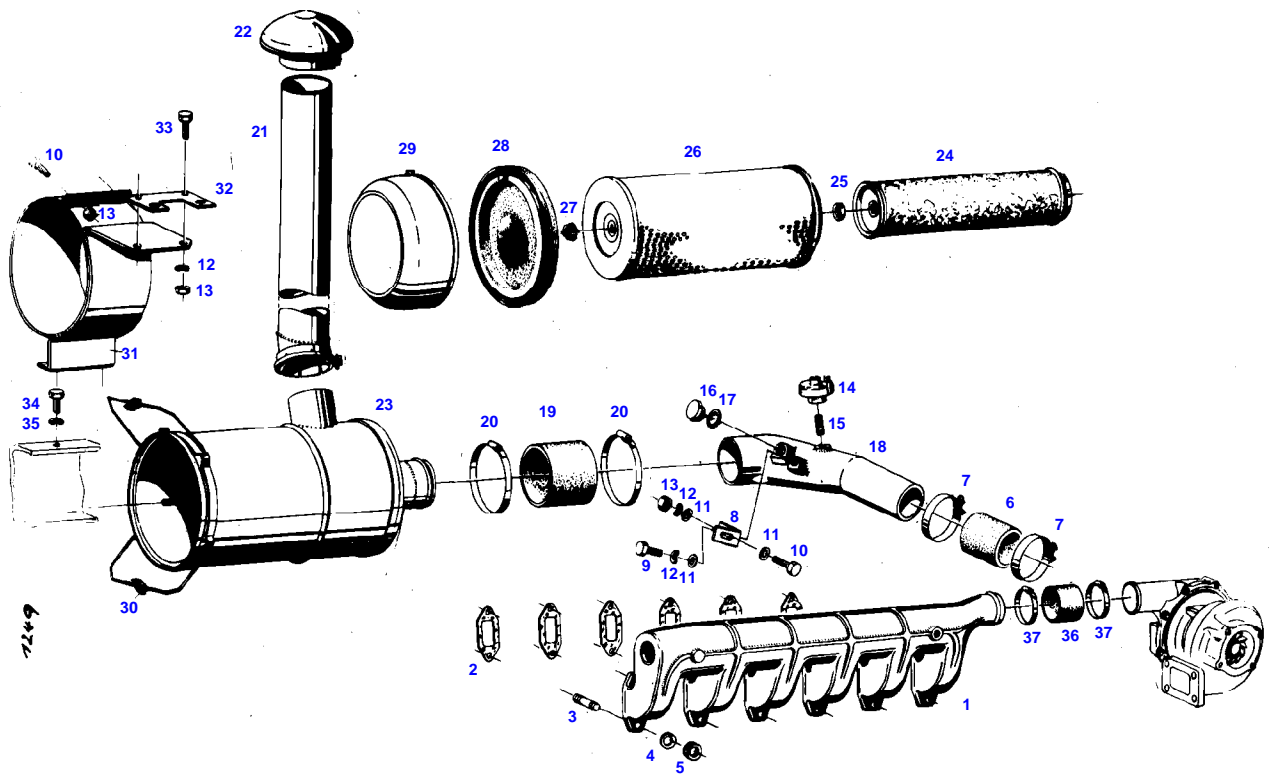

Item	Part Number	Qty	Description Comments	Technical Specification
			<b>PICLON</b>	
1	72340927	1	INTAKE MANIFOLD ENG.NO. --> 226.6.2.92490 <> <>	
	72373975	1	SCREW	DIN 910 M20X1,5-ST
	72315438	1	PLUG SCREW NOT ILLUSTRATED	DIN 908 M14X1,5-ST
	72315094	1	SEALING WASHER NOT ILLUSTRATED	DIN 7603 A14X18-CU
2	72332145	6	MOLDED SEAL	
3	72373922	12	STUD BOLT	DIN 835-M10X25-8.8
4	72315054	12	SPLIT WASHER	FWN 65208-10-A3L
5	72313272	12	NUT	DIN 934 M10-8A3L
6	72377623	1	HOSE	68X76X70-SILICON
7	72373528	2	HOSE CLIP	
8	72404947	1	ANGLE	
9	72315646	1	HEXAGONAL HEAD BOLT	DIN 933 M8X18-8.8A3L
10	72315653	3	HEXAGONAL HEAD BOLT	DIN 933 M8 X 25-8.8A3L
11	72311788	3	DISC	DIN 125-8,4-ST.A3L
12	72315053	4	SPLIT WASHER	FWN 65208-8-A3L
13	72313268	5	NUT	DIN 934 M8-8A3L
14	72316876	1	MAINTENANCE SWITCH <>	
	72380356	1	CABLE LUG	
	72314686	1	PLUG IN SLEEVE	
	72379175	0	WIRE	B1,5 DIN72551/6.51 SCHWARZ
15	72339032	1	THREADED SOCKET	
16	72315442	1	PLUG	DIN 908 M22X1,5-ST
17	72315101	1	SEALING WASHER	DIN 7603 A22X27-CU
18	72405867	1	INTAKE MANIFOLD --> 285/0676	
	72409379	1	INTAKE MANIFOLD <-- 285/0677 <>	
	72373975	1	SCREW	DIN 910 M20X1,5-ST
19	72395094	1	RUBBER PIECE	
20	72311173	2	HOSE CLIP	
21	72340120	1	INTAKE MANIFOLD	
22	72332141	1	RAIN CAP	
23	72349691	1	AIR FILTER >>23-30	
	72340122	1	DIFFUSER NOT ILLUSTRATED	
24	72332148	1	SAFETY CARTRIDGE	
25	72313299	1	NUT	DIN 936-M16X1,5-17H
26	72332142	1	MICRO-TOP CARTRIDGE	
27	72339030	1	COLLAR NUT	
28	72332146	1	INTERMEDIATE PLATE	
29	72340121	1	CUP	
30	72326152	2	TENSIONING DEVICE	
	72340124	2	HOLDER NOT ILLUSTRATED	
	72340123	2	RETAINER NOT ILLUSTRATED	
31	72364630	1	BAND CLAMP <>	
	72409006	1	RETAINING SHEET METAL	
32	72404945	1	RETAINING SHEET METAL	
33	72315642	2	HEXAGONAL HEAD BOLT	DIN 933 M8 X 16-8.8A3L
34	72315645	2	HEXAGONAL HEAD BOLT	DIN 933 M8 X 12-8.8A3L
35	72317121	2	SPRING WASHER	DIN 137 B8-MECH.VZK
36	72332139	1	HOSE PIECE	
37	72311163	2	HOSE CLIP	

---

Fendt

FAVORIT 615 (285/00001-99999)

F285000

AIR FILTER

Page01-0016

---

Item	Part Number	Qty	Description Comments	Technical Specification
38	72406017	1	ABSORPTION INDICATOR (1,9) NOT ILLUSTRATED	

FAVORIT 615 (285/00001-99999)  
3179

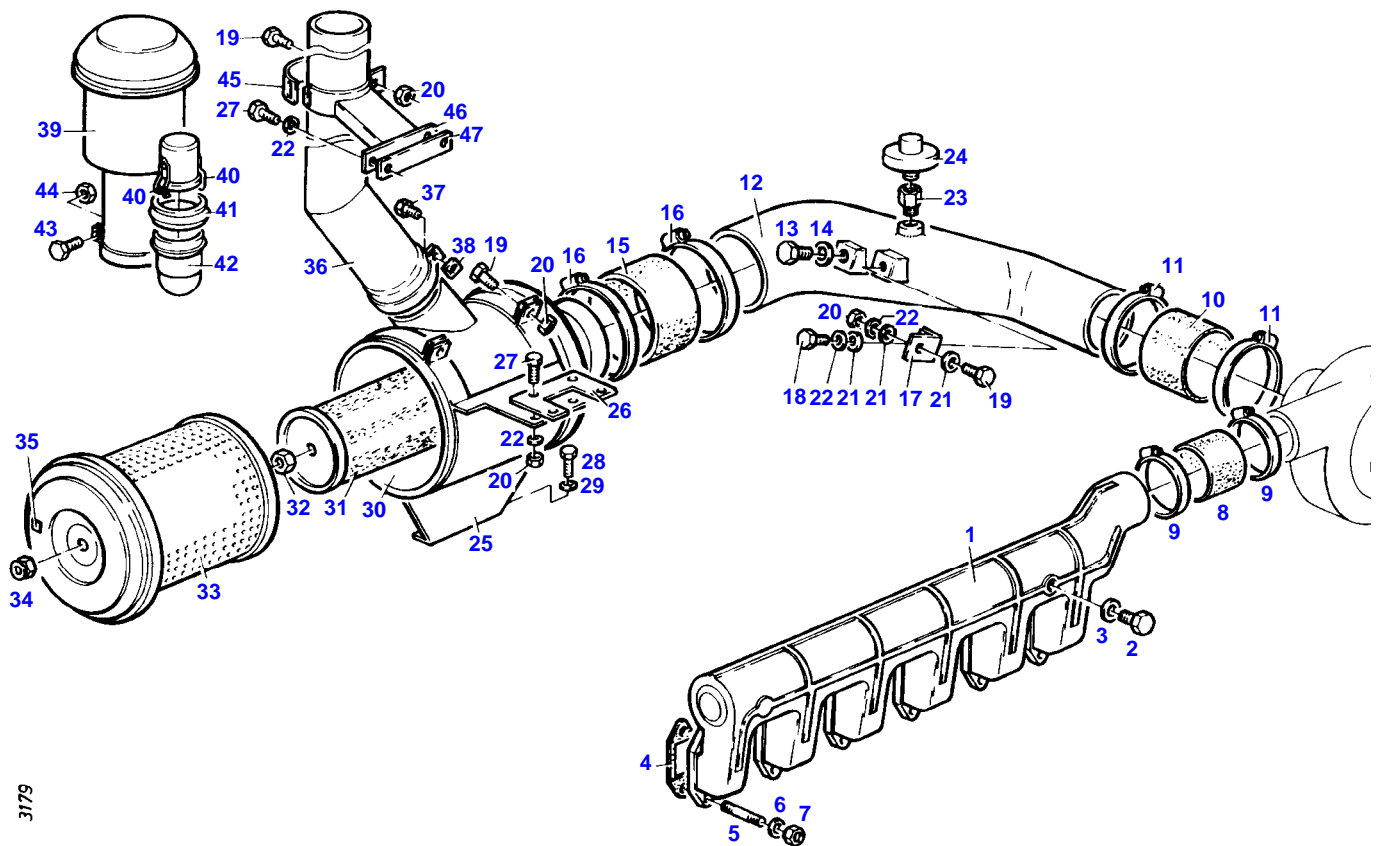

3179



Item	Part Number	Qty	Description Comments	Technical Specification
			<b>PICO</b>	
1	72340927	1	INTAKE MANIFOLD ENG.NO. --> 226.6.2.92490 <> <>	
	72373975	1	SCREW	DIN 910 M20X1,5-ST
2	72373971	1	PLUG	DIN 910 M14X1,5-ST
3	72315094	1	SEALING WASHER	DIN 7603 A14X18-CU
4	72332145	6	MOLDED SEAL	
5	72373922	12	STUD BOLT	DIN 835-M10X25-8.8
6	72315054	12	SPLIT WASHER	FWN 65208-10-A3L
7	72373015	12	NUT	DIN70615-M10-8-A3B
8	72332139	1	HOSE PIECE	
9	72311163	2	HOSE CLIP	
10	72377623	1	HOSE	68X76X70-SILICON
11	72373528	2	HOSE CLIP	
12	72405867	1	INTAKE MANIFOLD --> 285/0676 <-- 285/0677	
	72409379	1	INTAKE MANIFOLD	
13	72315442	1	PLUG	DIN 908 M22X1,5-ST
14	72315101	1	SEALING WASHER	DIN 7603 A22X27-CU
15	72395094	1	RUBBER PIECE	
16	72311173	2	HOSE CLIP	
17	72404947	1	ANGLE	
18	72315646	1	HEXAGONAL HEAD BOLT	DIN 933 M8X18-8.8A3L
19	72315653	4	HEXAGONAL HEAD BOLT	DIN 933 M8 X 25-8.8A3L
20	72313268	6	NUT	DIN 934 M8-8A3L
21	72311788	3	DISC	DIN 125-8,4-ST.A3L
22	72315053	6	SPLIT WASHER	FWN 65208-8-A3L
23	72339032	1	THREADED SOCKET	
24	72316876	1	MAINTENANCE SWITCH <>	
	72314686	1	PLUG IN SLEEVE	
	72380356	1	CABLE LUG	
	72379175	0	WIRE	B1,5 DIN72551/6.51 SCHWARZ
25	72364631	1	RETAINER <>	
	72409006	1	RETAINING SHEET METAL	
26	72404945	1	RETAINING SHEET METAL	
27	72315642	4	HEXAGONAL HEAD BOLT	DIN 933 M8 X 16-8.8A3L
28	72315645	2	HEXAGONAL HEAD BOLT	DIN 933 M8 X 12-8.8A3L
29	72317121	2	SPRING WASHER	DIN 137 B8-MECH.VZK
30	72349678	1	AIR FILTER ><30-34	
31	72339772	1	SAFETY CARTRIDGE	
32	72313299	1	NUT	DIN 936-M16X1,5-17H
33	72339771	1	MICRO-TOP CARTRIDGE	
34	72313243	1	COLLAR NUT	
35	72406017	1	ABSORPTION INDICATOR (1,9)	
36	72349681	1	INTAKE MANIFOLD ><37,38 --> 285/0581 <> <>	
	72349682	1	CYCLONE AIR CLEANER	
37			NO LONGER AVAILABLE	
38	72372783	1	SQUARE NUT	DIN 557 M6-5 A3L
39	72349682	1	CYCLONE AIR CLEANER ><39-44 --> 285/0581 <> <>	
	72349681	1	INTAKE MANIFOLD	

<b>Item</b>	<b>Part Number</b>	<b>Qty</b>	<b>Description Comments</b>	<b>Technical Specification</b>
40	72321921	2	CATCH	
41	72330736	1	FUNNEL	
42	72320204	1	CONTAINER	
43	72315685	1	HEXAGONAL HEAD BOLT	DIN 933 M10X30-8.8A3L
44	72313272	1	NUT	DIN 934 M10-8A3L
45	72404790	1	CLAMP	
46	72361972	1	RETAINER	
47	72409381	1	PLATE LINK	

FAVORIT 615 (285/00001-99999)  
1250

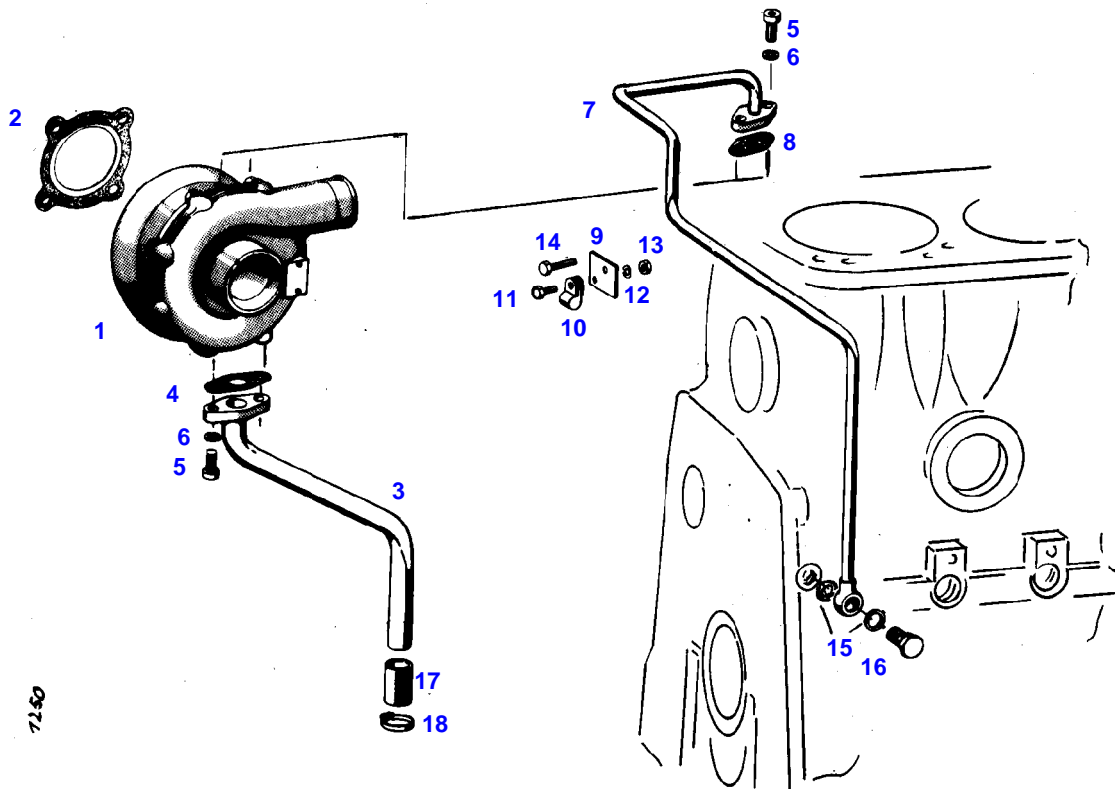

7140

Thank you so much for reading.  
Please click the “Buy Now!”  
button below to download the  
complete manual.



After you pay.

You can download the most  
perfect and complete manual in  
the world immediately.

Our support email:

[ebooklibonline@outlook.com](mailto:ebooklibonline@outlook.com)