

Page Number	Page Title	Page Reference
01-000-TOC	ENGINE, FUEL AND EXHAUST SYSTEM	01-000-TOC
02-000-TOC	AXLES	02-000-TOC
03-000-TOC	STEERING SYSTEM	03-000-TOC
04-000-TOC	DRIVE TRAIN SYSTEM	04-000-TOC
05-000-TOC	COMPRESSED AIR SYSTEM	05-000-TOC
06-000-TOC	HYDRAULIC SYSTEM	06-000-TOC
07-000-TOC	ELECTRICAL SYSTEM	07-000-TOC
08-000-TOC	CAB	08-000-TOC
09-000-TOC	AIR CONDITIONING AND HEATING SYSTEM	09-000-TOC
10-000-TOC	CHASSIS	10-000-TOC
11-000-TOC	WHEELS	11-000-TOC
12-000-TOC	IMPLEMENT LIFT SYSTEM FRONT	12-000-TOC
13-000-TOC	IMPLEMENT LIFT SYSTEM REAR	13-000-TOC
14-000-TOC	FRONT/REAR LOADERS	14-000-TOC
15-000-TOC	ACCESSORIES	15-000-TOC

FAVORIT 611 (382/00001-99999)
3176

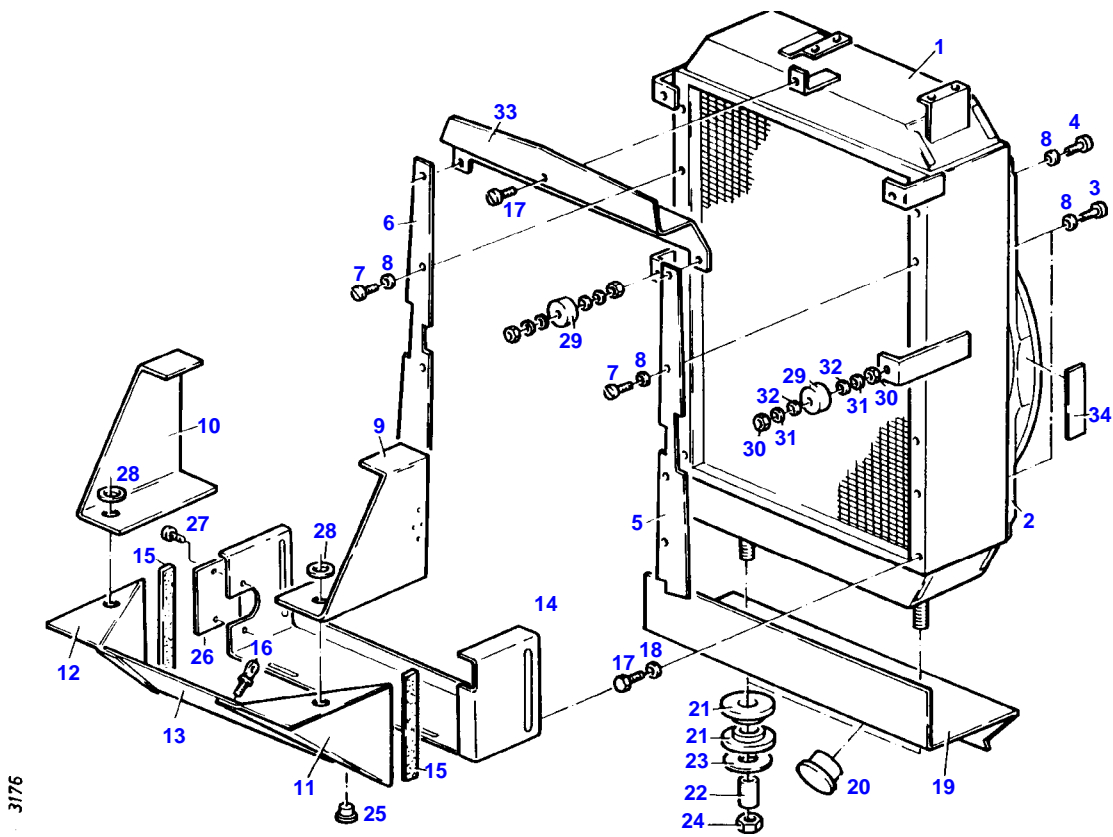

3176

Item	Part Number	Qty	Description Comments	Technical Specification
			--> 382/2000	
1	72364550	1	RADIATOR	
	72364542	1	RADIATOR SAUDI-ARABIA	
	72364625	1	RADIATOR AIR CONDITION	
2	72409350	1	FAN COVER	
3	72315818	4	SCREW	DIN7976-ST4,2X25-C-A3L
4	72315787	2	SCREW	DIN 7981 B4,2X16-A3L
5	72409063	1	BARRIER WALL	
6	72409064	1	BARRIER WALL	
7	72315781	8	SCREW	DIN 7981 ST3,5X9,5-C-H-A3
	72315812	2	SCREW SAUDI-ARABIA	DIN 7981 ST4,2X9,5-F-H-A3
8	72311817	14	DISC	DIN9021-4,3-140HV-A3L
9	72409067	1	RETAINER	
	72405884	1	RETAINER SAUDI-ARABIA	
10	72409068	1	RETAINER	
	72405885	1	RETAINER SAUDI-ARABIA	
11	72405887	1	GUSSET PLATE LEFT	
12	72405890	1	GUSSET PLATE RIGHT	
13	72405892	1	FLOOR SHEET	
14	72364553	1	FRAME	
15	72450971	1	SHAPED CORD 2X 170 MM CUT TO LENGTH	L=1000 FWN 63040 C02
16	72334276	2	CATCH	
17	72374968	5	SCREW	DIN7976-ST4,8X9,5-C-A3L
18	72311818	5	DISC	DIN9021-5,3-140HV-A3L
19	72409062	1	SPLASH PANEL	
20	72375084	1	LOCKING PLUG	SW-F35
21	72311639	4	RADIATOR DAMPER	
22	72310742	2	BUSH	
23	72311849	2	DISC	
24	72313325	2	NUT	DIN 980-VM12-8-A3L
	72313327	2	NUT SAUDI-ARABIA	DIN 980-VM14-8-A3L
25	72426777	1	LOCKING PLUG	F5
26	72409059	1	COVER PLATE	
27	72315812	2	SCREW	DIN 7981 ST4,2X9,5-F-H-A3
28	72311793	2	DISC	DIN 125-17-ST.A3L
29	72310623	2	BUFFER	
30	72313266	4	NUT	DIN 934 M6-8A3L
31	72311822	4	DISC	DIN9021-6,4-140HV-A3L
32	72317120	4	SPRING WASHER	DIN 137 B6-MECH.VZK
33	72409061	1	SPLASH PANEL	
34	72386100	2	WARNING SIGN D	
	72388085	2	WARNING SIGN GB	
	72388086	2	WARNING SIGN F	
	72388087	2	WARNING SIGN I	
	72388088	2	WARNING SIGN E	

FAVORIT 611 (382/00001-99999)
5547

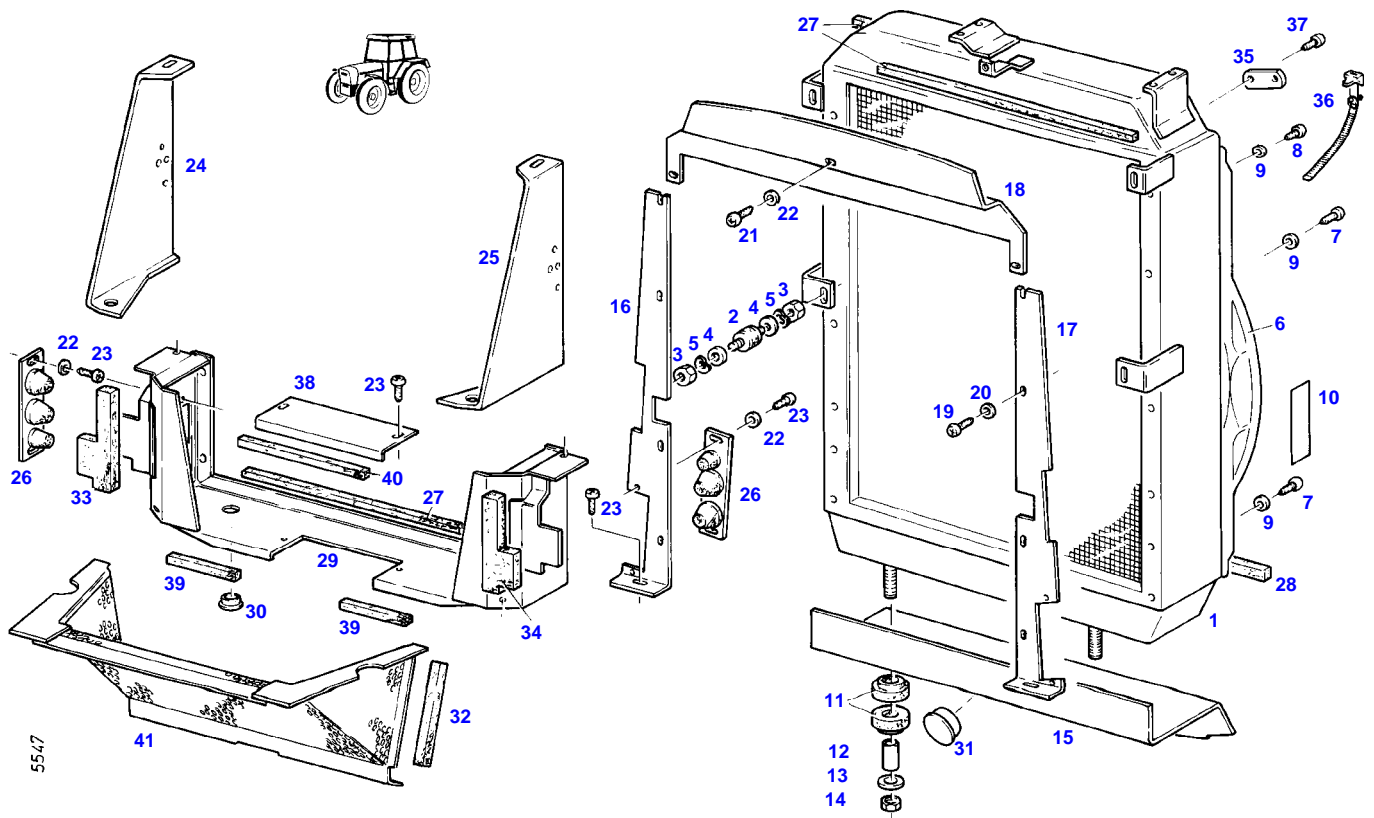

Item	Part Number	Qty	Description Comments	Technical Specification
			<-- 382/2001	
1	72364677	1	RADIATOR	
2	72310623	2	BUFFER	
3	72313266	4	NUT	DIN 934 M6-8A3L
4	72311822	4	DISC	DIN9021-6,4-140HV-A3L
5	72317120	4	SPRING WASHER	DIN 137 B6-MECH.VZK
6	72409350	1	FAN COVER	
7	72315818	4	SCREW	DIN7976-ST4,2X25-C-A3L
8	72315787	2	SCREW	DIN 7981 B4,2X16-A3L
9	72311817	6	DISC	DIN9021-4,3-140HV-A3L
10	72386100	2	WARNING SIGN D	
	72388085	2	WARNING SIGN GB	
	72388086	2	WARNING SIGN F	
	72388087	2	WARNING SIGN I	
	72388088	2	WARNING SIGN E	
11	72311639	4	RADIATOR DAMPER	
	72409375	4	DISC	
12	72310742	2	BUSH	
			--> 382/2557	
	72391200	2	SPACER BUSHING <-- 382/2558	
13	72311849	2	DISC	
14	72313325	2	NUT	DIN 980-VM12-8-A3L
15	72409357	1	SPLASH PANEL	
	72409371	1	SPLASH PANEL DUO-SPEED	
16	72409358	1	SPLASH PANEL	
17	72409359	1	SPLASH PANEL	
18	72409360	1	SPLASH PANEL	
19	72315781	8	SCREW	DIN 7981 ST3,5X9,5-C-H-A3
20	72311817	8	DISC	DIN9021-4,3-140HV-A3L
21	72374968	5	SCREW	DIN7976-ST4,8X9,5-C-A3L
22	72311818	15	DISC	DIN9021-5,3-140HV-A3L
23	72315812	10	SCREW	DIN 7981 ST4,2X9,5-F-H-A3
24	72409361	1	RETAINER	
25	72409362	1	RETAINER	
26	72397352	3	SEAL	
27	72409365	3	SEALING STRIP	
28	72409366	1	SEALING STRIP	
29	72364682	1	FRAME	
	72314747	4	LOCKING PLUG <-- 382/2558	F10
	72364684	1	FRAME DUO-SPEED <-- 382/2558	
30	72314762	2	LOCKING PLUG	SW-F182
31	72375085	1	LOCKING PLUG	F40
32	72409367	2	SEALING STRIP	
33	72409368	1	SEALING STRIP	
34	72409369	1	SEALING STRIP	
35	72408131	1	PLATE LINK	
36	72316911	2	CABLE STRAP	FWN 66650 A160X9-SW
37	72374969	1	SCREW	DIN7976-ST4,8X19-C-A3L
38	72409372	1	COVER	
39	72392396	2	STRAP	
	72409373	1	SEALING STRIP	
	72409374	1	SEALING STRIP DUO-SPEED	

Fendt

FAVORIT 611 (382/00001-99999)

F382000

WATER COOLED RADIATOR

Page01-0008

Item	Part Number	Qty	Description Comments	Technical Specification
40	72392396	1	STRAP DUO-SPEED	
41	72364679	1	SCREEN FRAME	

FAVORIT 611 (382/00001-99999)
9349

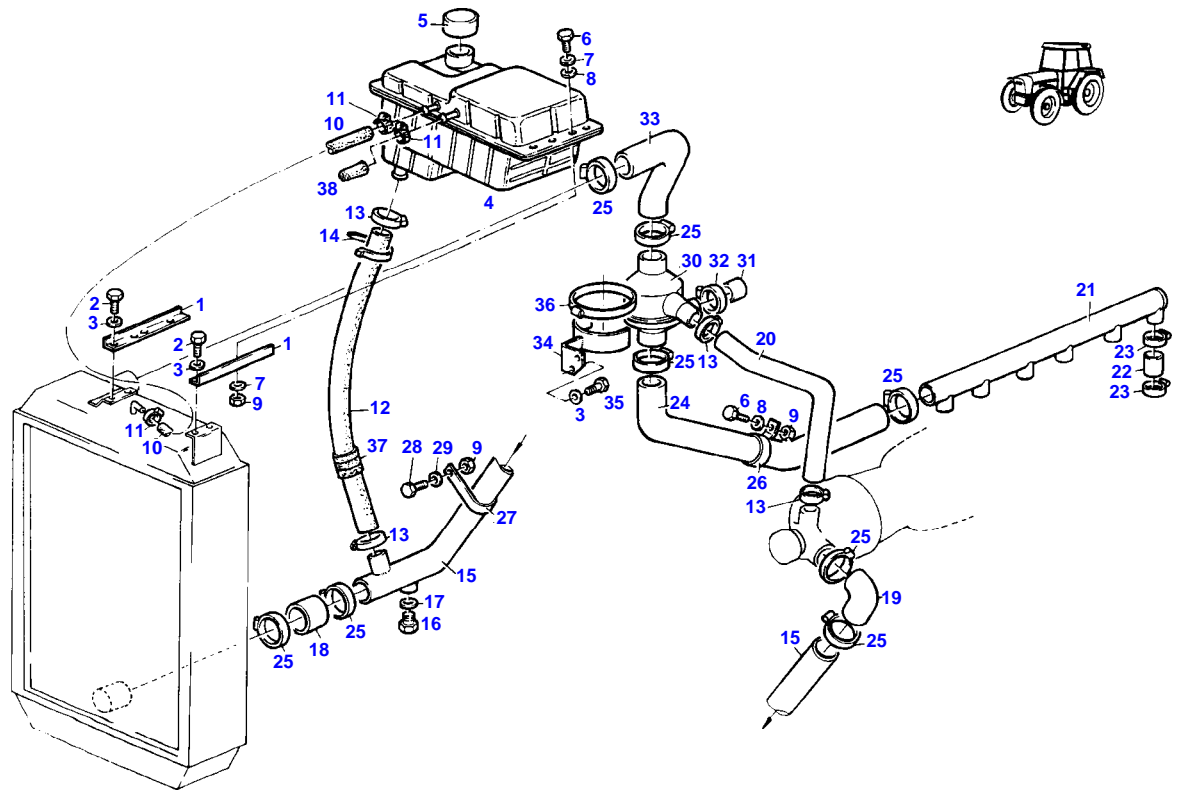

9349

Item	Part Number	Qty	Description Comments	Technical Specification
			--> 382/2000	
1	72409065	2	ANGLE	
2	72374968	4	SCREW	DIN7976-ST4,8X9,5-C-A3L
3	72311818	6	DISC	DIN9021-5,3-140HV-A3L
4	72316897	1	EXPANSION TANK <> 11(1X),38 <>	
	72438345	3	HOSE CLIP	
	72409370	1	CAP	
5	72348672	1	COLLER LOCKING	
6	72315626	5	HEXAGONAL HEAD BOLT	DIN 933-M6 X 16-8.8-A3L
7	72311787	8	DISC	DIN 125-6,4-ST.A3L
8	72317120	5	SPRING WASHER	DIN 137 B6-MECH.VZK
9	72313266	6	NUT	DIN 934 M6-8A3L
10	72622024	1	PRESSURE HOSE 140 MM CUT TO LENGTH	L=0,50M 8X3,5-FWN65911
11	72438345	3	HOSE CLIP	
12	72450412	1	HOSE 1X 700MM CUT TO LENGTH	L=1000 18X3,5 R DIN 73411
13	72311167	5	HOSE CLIP	
14	72316913	1	CABLE STRAP	FWN 66650 B360X7,5-SW
15	72364551	1	SUCTION LINE	
	72364552	1	SUCTION LINE WITHOUT HEATING	
16	72315799	1	PLUG	DIN 7604 AM14X1,5-A3L
17	72315094	1	SEALING WASHER	DIN 7603 A14X18-CU
18	72450416	1	HOSE 1X 60MM CUT TO LENGTH	L=120 DIN73411-35X
19	72399873	1	RUBBER ARCH	
20	72404921	1	RUBBER ARCH	
21	72343591	1	COOLING WATER SUPPLY LINE	
22	72450415	1	HOSE 6X 30MM CUT TO LENGTH	L=900 DIN73411-22X3,5 R
23	72337051	12	PIPE CLAMP	
	72311167	12	HOSE CLIP	
24	72404920	1	RUBBER ARCH	
25	72311162	8	HOSE CLIP	
26	72404929	1	CLAMP	
27	72394567	1	FASTENING COLLAR	
28	72315631	1	HEXAGONAL HEAD BOLT	DIN 933 M6 X 20-8.8A3L
29	72311822	1	DISC	DIN9021-6,4-140HV-A3L
30	72380194	1	THERMOSTAT	
31	72404925	1	CAP WITHOUT HEATING	
32	72311167	1	HOSE CLIP WITHOUT HEATING	
33	72409301	1	RUBBER ARCH	
34	72409060	1	RETAINER	
35	72374969	2	SCREW	DIN7976-ST4,8X19-C-A3L
36	72373528	1	HOSE CLIP	
37	72436297	1	HOSE PROTECTOR 1X 520 MM CUT TO LENGTH	L=920
38	72409370	1	CAP	

FAVORIT 611 (382/00001-99999)
9350

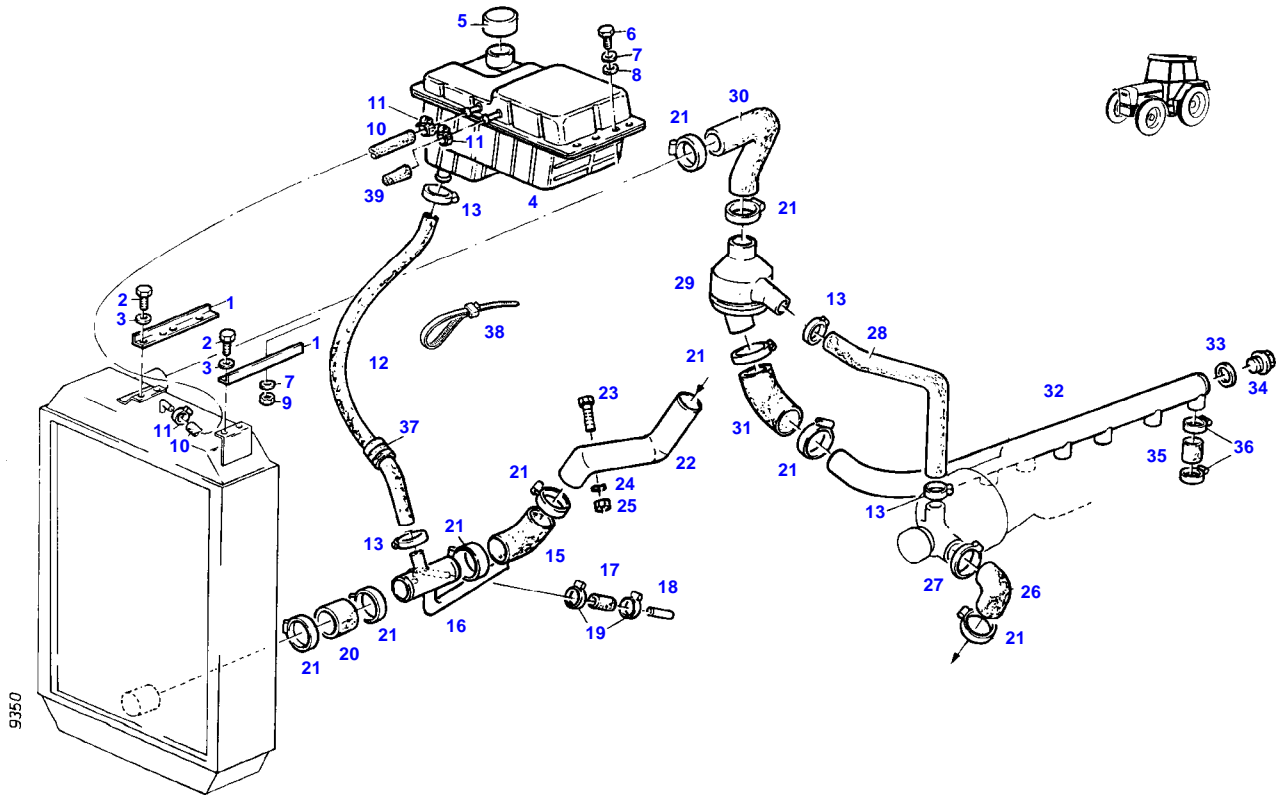

Item	Part Number	Qty	Description Comments	Technical Specification
			<-- 382/2001	
1	72409065	2	ANGLE	
2	72374968	4	SCREW	DIN7976-ST4,8X9,5-C-A3L
3	72311818	4	DISC	DIN9021-5,3-140HV-A3L
4	72316897	1	EXPANSION TANK <> 11(1X),39 <>	
	72438345	2	HOSE CLIP	
	72409370	1	CAP	
5	72348672	1	COLLER LOCKING	
6	72315626	4	HEXAGONAL HEAD BOLT	DIN 933-M6 X 16-8.8-A3L
7	72311787	8	DISC	DIN 125-6,4-ST.A3L
8	72317120	4	SPRING WASHER	DIN 137 B6-MECH.VZK
9	72313266	4	NUT	DIN 934 M6-8A3L
10	72622024	1	PRESSURE HOSE 1X 150MM CUT TO LENGTH	L=0,50M 8X3,5-FWN65911
11	72438345	3	HOSE CLIP	
	72438345	2	HOSE CLIP DUO-SPEED	
12	72450412	1	HOSE 1X 740MM CUT TO LENGTH	L=1000 18X3,5 R DIN 73411
13	72311167	4	HOSE CLIP	
15	72409354	1	RUBBER ARCH	
16	72364676	1	SUCTION PIPE	
17	72436024	1	HOSE 1X 50MM CUT TO LENGTH	L=920 DIN73411-15X3,5 R
18	72432117	1	BOLT	
19	72311167	2	HOSE CLIP	
20	72450417	1	HOSE 1X 80MM CUT TO LENGTH	L=100 DIN73411-45X5 R
21	72311163	9	HOSE CLIP	
22	72364680	1	SUCTION PIPE	
23	72315660	1	HEXAGONAL HEAD BOLT	DIN 933 M8X35-8.8A3L
24	72317121	1	SPRING WASHER	DIN 137 B8-MECH.VZK
25	72313268	1	NUT	DIN 934 M8-8A3L
26	72409352	1	RUBBER ARCH	
27	72311162	1	HOSE CLIP	
28	72409355	1	RUBBER ARCH	
29	72456610	1	THERMOSTAT	
30	72409356	1	RUBBER ARCH	
31	72409353	1	RUBBER ARCH	
32	72364675	1	PRESSURE LINE	
33	72315101	1	SEALING WASHER	DIN 7603 A22X27-CU
34	72315802	1	SCREW	DIN 7604 AM22X1,5-ST
35	72450415	1	HOSE 6X 30MM CUT TO LENGTH	L=900 DIN73411-22X3,5 R
36	72330789	12	PIPE CLAMP	
	72311167	12	HOSE CLIP	
37	72436297	1	HOSE PROTECTOR 1X 520 MM CUT TO LENGTH	L=920
38	72316913	1	CABLE STRAP	FWN 66650 B360X7,5-SW
39	72409370	1	CAP	

FAVORIT 611 (382/00001-99999)
5557

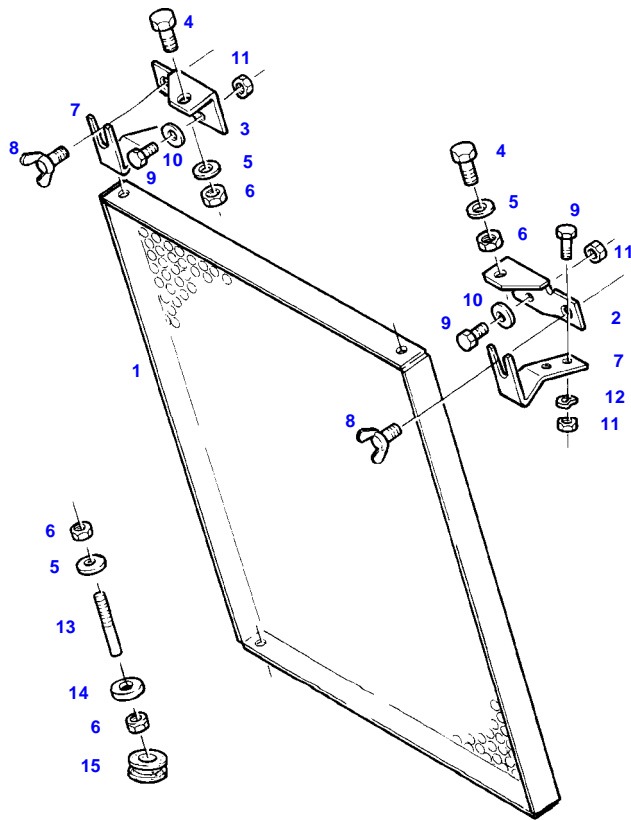

5557

Item	Part Number	Qty	Description Comments	Technical Specification
			<-- 382/2001	
1	72409404	1	BAFFLE	
2	72364815	1	RETAINING BRACKET	
3	72364816	1	RETAINING BRACKET	
4	72315645	2	HEXAGONAL HEAD BOLT	DIN 933 M8 X 12-8.8A3L
5	72311788	4	DISC	DIN 125-8,4-ST.A3L
6	72313268	6	NUT	DIN 934 M8-8A3L
7	72409679	2	RETAINER	
8	72432444	2	WING SCREW	DIN 316 M8X20-DELTA SEAL
9	72315629	6	HEXAGONAL HEAD BOLT	DIN 933 M6 X 12-8.8A3L
10	72311822	2	DISC	DIN9021-6,4-140HV-A3L
11	72313266	6	NUT	DIN 934 M6-8A3L
12	72317120	4	SPRING WASHER	DIN 137 B6-MECH.VZK
13	72310483	2	BOLT	
14	72311848	2	DISC	
15	72316284	2	CABLE BUSHING	

FAVORIT 611 (382/00001-99999)
6084

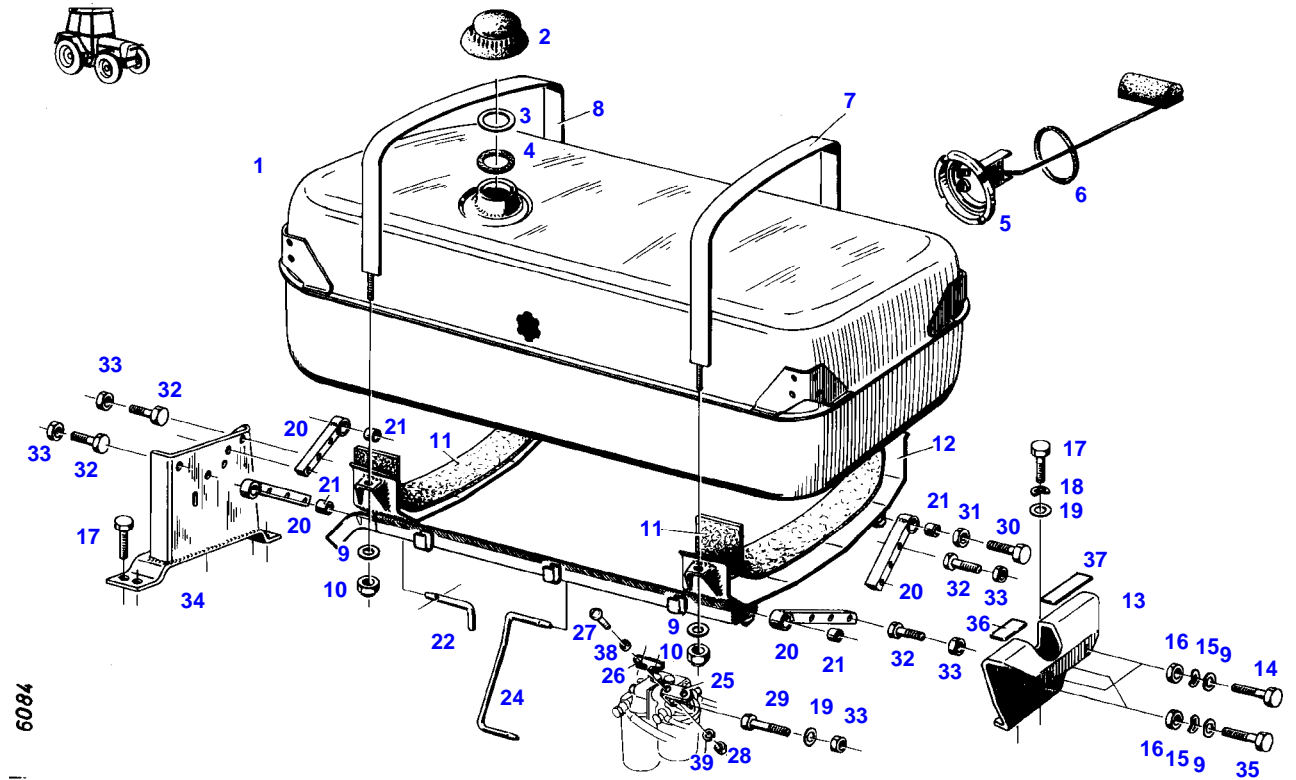

Item	Part Number	Qty	Description Comments	Technical Specification
			--> 382/2000	
1	72364691	1	FUEL TANK	
2	72350303	1	FUEL CAP	
			><2-4	
	72394572	1	PLASTIC CAP	
3	72330726	1	SEAL	
			BLAU	
4	72330725	1	SEAL	
			BLAU	
	72312304	1	RUBBER SEAL	
			KOEHLER	
5	72613427	1	FUEL LEVEL SENSOR	
			><5+6	
	72380148	1	FUEL LEVEL SENSOR	
			><5+6	
			ADDITIONAL CONTAINER	
6	72315169	1	SEALING WASHER	
7	72362041	1	BAND CLAMP	
8	72362042	1	BAND CLAMP	
9	72311788	8	DISC	DIN 125-8,4-ST.A3L
10	72313320	4	NUT	DIN6925-M8-8-A3L
11	72404934	2	FELT TAPE	
12	72364628	1	FRAME	
13	72409303	1	CONSOLE	
14	72315659	1	HEXAGONAL HEAD BOLT	DIN 933 M8X35-8.8
15	72315053	4	SPLIT WASHER	FWN 65208-8-A3L
16	72313268	4	NUT	DIN 934 M8-8A3L
17	72315678	7	HEXAGONAL HEAD BOLT	DIN 933 M10X20-8.8
18	72315054	2	SPLIT WASHER	FWN 65208-10-A3L
19	72311789	2	DISC	DIN 125-10,5-ST.A3L
20	72404942	4	SUPPORT ARM	
21	72310644	4	RUBBER BUSHING	
22	72397322	1	BEARING PIN	
24	72404936	1	BEARING PIN	
25	72404938	1	ANGLE	
26	72399331	1	RETAINER	
27	72315619	2	HEXAGONAL HEAD BOLT	DIN 933 M5X16-8.8A3L
28	72313264	2	NUT	DIN 934 M5-8A3L
29	72315689	1	HEXAGONAL HEAD BOLT	DIN 933 M10X35-8.8A3L
30	72374215	2	HEXAGONAL HEAD BOLT	DIN 931 M12X65-8.8
31	72313325	2	NUT	DIN 980-VM12-8-A3L
32	72315693	7	HEXAGONAL HEAD BOLT	DIN 933 M10X45-8.8A3L
	72374898	1	SOCKET HEAD BOLT	DIN 6912-M10X45-8.8
33	72313272	8	NUT	DIN 934 M10-8A3L
34	72364688	1	CONSOLE	
35	72315663	3	HEXAGONAL HEAD BOLT	DIN 933 M8X40-8.8A3L
36	72404939	1	BAND	
37	72404943	1	BAND	
38	72311818	2	DISC	DIN9021-5,3-140HV-A3L
39	72315051	2	SPLIT WASHER	FWN 65208-5-A3L

FAVORIT 611 (382/00001-99999)
5741

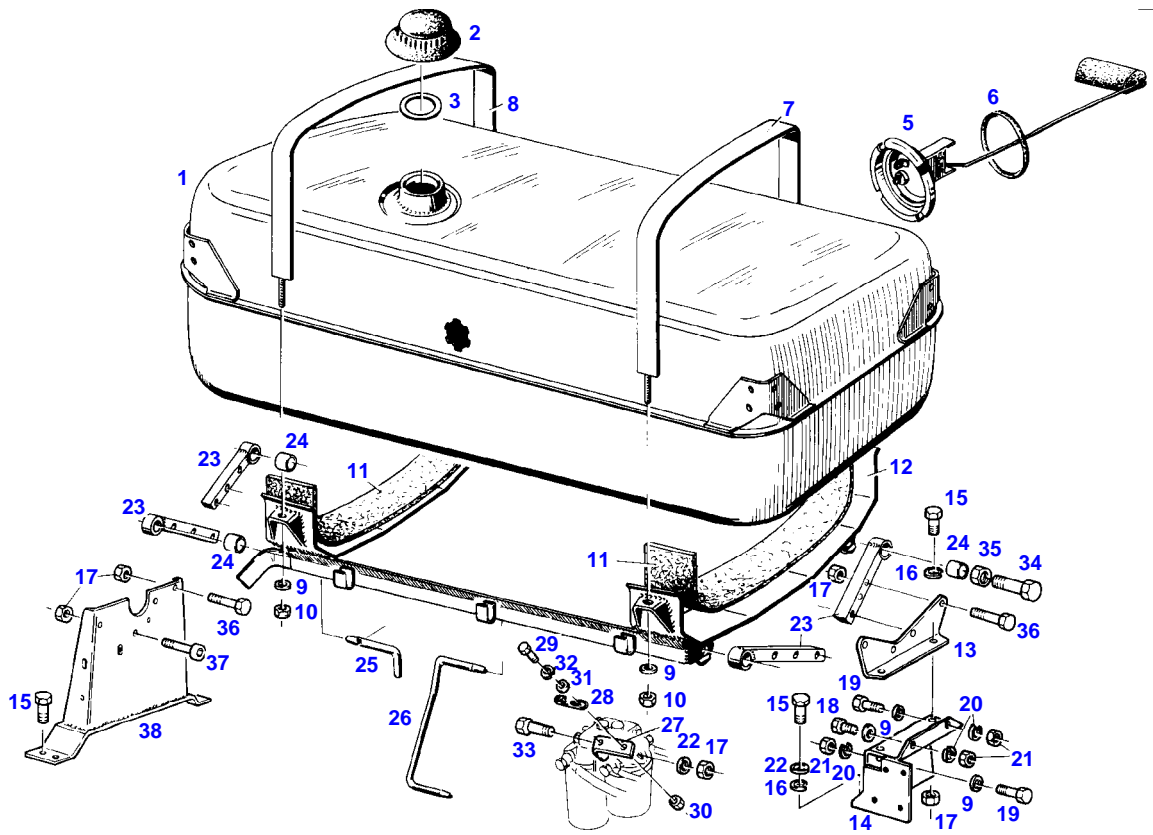

5741

Item	Part Number	Qty	Description Comments	Technical Specification
			<-- 382/2001 --> 382/2257	
1	72364691	1	FUEL TANK	
2	72350303	1	FUEL CAP	
			><2+3	
3	72312304	1	RUBBER SEAL	
5	72613427	1	FUEL LEVEL SENSOR	
			><5+6	
	72380148	1	FUEL LEVEL SENSOR	
			><5+6	
			ADDITIONAL CONTAINER	
6	72315169	1	SEALING WASHER	
7	72362041	1	BAND CLAMP	
8	72362042	1	BAND CLAMP	
9	72311788	8	DISC	DIN 125-8,4-ST.A3L
10	72313320	4	NUT	DIN6925-M8-8-A3L
11	72404934	2	FELT TAPE	
12	72364628	1	FRAME	
13	72409376	1	BRACKET	
14	72364687	1	CONSOLE	
15	72315678	9	HEXAGONAL HEAD BOLT	DIN 933 M10X20-8.8
16	72315054	4	SPLIT WASHER	FWN 65208-10-A3L
17	72313272	10	NUT	DIN 934 M10-8A3L
18	72315659	1	HEXAGONAL HEAD BOLT	DIN 933 M8X35-8.8
19	72315663	3	HEXAGONAL HEAD BOLT	DIN 933 M8X40-8.8A3L
20	72315053	4	SPLIT WASHER	FWN 65208-8-A3L
21	72313268	4	NUT	DIN 934 M8-8A3L
22	72311789	2	DISC	DIN 125-10,5-ST.A3L
23	72404942	4	SUPPORT ARM	
24	72310644	4	RUBBER BUSHING	
25	72397322	1	BEARING PIN	
26	72404936	1	BEARING PIN	
27	72404938	1	ANGLE	
28	72399331	1	RETAINER	
29	72315619	2	HEXAGONAL HEAD BOLT	DIN 933 M5X16-8.8A3L
30	72313264	2	NUT	DIN 934 M5-8A3L
31	72311818	2	DISC	DIN9021-5,3-140HV-A3L
32	72315051	2	SPLIT WASHER	FWN 65208-5-A3L
33	72315689	1	HEXAGONAL HEAD BOLT	DIN 933 M10X35-8.8A3L
34	72374215	2	HEXAGONAL HEAD BOLT	DIN 931 M12X65-8.8
35	72313325	2	NUT	DIN 980-VM12-8-A3L
36	72315693	7	HEXAGONAL HEAD BOLT	DIN 933 M10X45-8.8A3L
37	72374898	1	SOCKET HEAD BOLT	DIN 6912-M10X45-8.8
38	72364688	1	CONSOLE	

FAVORIT 611 (382/00001-99999)
6088

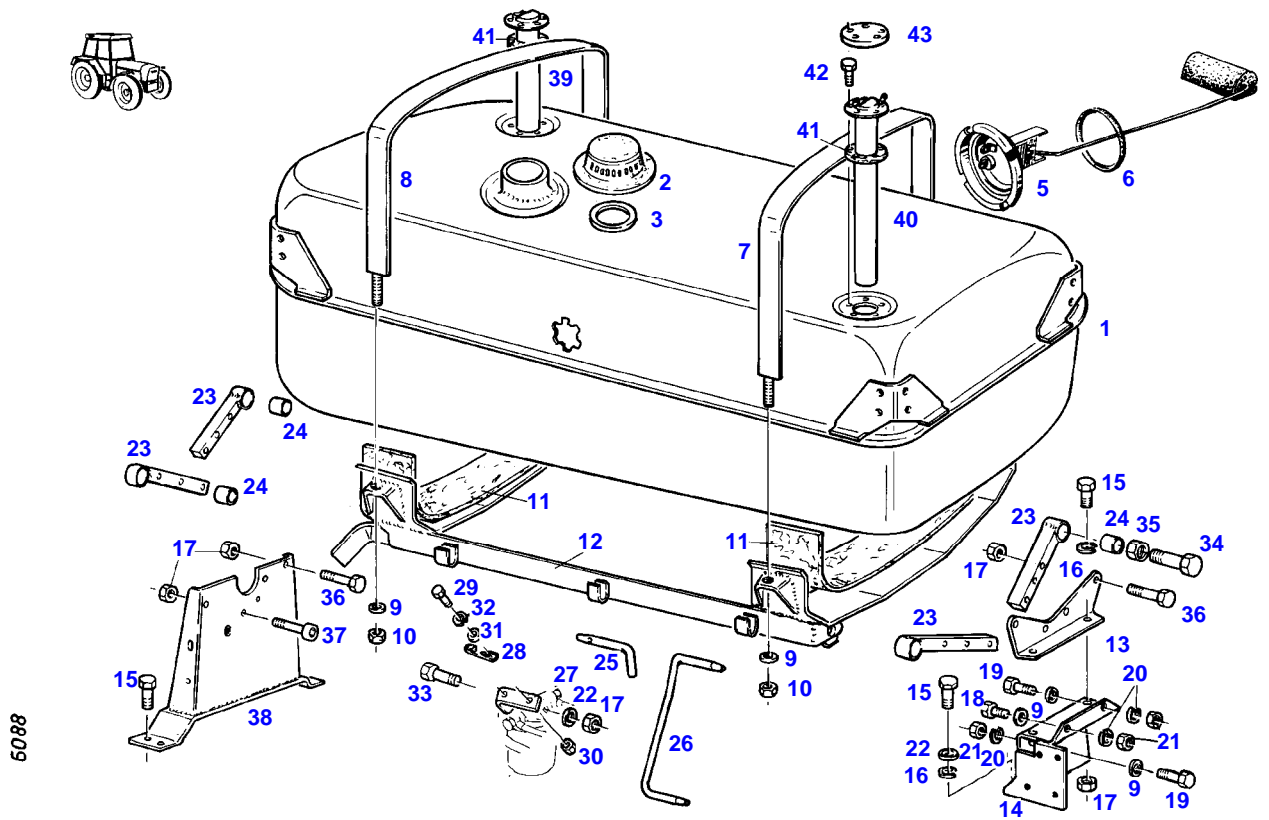

Item	Part Number	Qty	Description Comments	Technical Specification
BOARD COMPUTER				
1	72364691	1	FUEL TANK	
2	72350303	1	FUEL CAP ><2+3	
3	72312304	1	RUBBER SEAL	
5	72613427	1	FUEL LEVEL SENSOR ><5+6	
	72380148	1	FUEL LEVEL SENSOR ><5+6 ADDITIONAL CONTAINER	
6	72315169	1	SEALING WASHER	
7	72362041	1	BAND CLAMP	
8	72362042	1	BAND CLAMP	
9	72311788	8	DISC	DIN 125-8,4-ST.A3L
10	72313320	4	NUT	DIN6925-M8-8-A3L
11	72404934	2	FELT TAPE	
12	72364628	1	FRAME	
13	72409376	1	BRACKET	
14	72364687	1	CONSOLE	
15	72315678	9	HEXAGONAL HEAD BOLT	DIN 933 M10X20-8.8
16	72315054	4	SPLIT WASHER	FWN 65208-10-A3L
17	72313272	12	NUT	DIN 934 M10-8A3L
18	72315659	1	HEXAGONAL HEAD BOLT	DIN 933 M8X35-8.8
19	72315663	3	HEXAGONAL HEAD BOLT	DIN 933 M8X40-8.8A3L
20	72315053	4	SPLIT WASHER	FWN 65208-8-A3L
21	72313268	4	NUT	DIN 934 M8-8A3L
22	72311789	2	DISC	DIN 125-10,5-ST.A3L
23	72404942	4	SUPPORT ARM	
24	72310644	4	RUBBER BUSHING	
25	72397322	1	BEARING PIN	
26	72404936	1	BEARING PIN	
27	72404938	1	ANGLE	
28	72399331	1	RETAINER	
29	72315619	2	HEXAGONAL HEAD BOLT	DIN 933 M5X16-8.8A3L
30	72313264	2	NUT	DIN 934 M5-8A3L
31	72311818	2	DISC	DIN9021-5,3-140HV-A3L
32	72315051	2	SPLIT WASHER	FWN 65208-5-A3L
33	72315689	1	HEXAGONAL HEAD BOLT	DIN 933 M10X35-8.8A3L
34	72374215	2	HEXAGONAL HEAD BOLT	DIN 931 M12X65-8.8
35	72313325	2	NUT	DIN 980-VM12-8-A3L
36	72315693	7	HEXAGONAL HEAD BOLT	DIN 933 M10X45-8.8A3L
37	72374898	1	SOCKET HEAD BOLT	DIN 6912-M10X45-8.8
38	72364688	1	CONSOLE	
39	72380152	1	FUEL LEVEL SENSOR	
40	72380153	1	FUEL LEVEL SENSOR <-- 382/2295	
41	72376132	2	SEALING WASHER 40,5X65X2,4 <-- 382/2295 <> X540 000 478 12X <>	
	72376017	12	SEALING WASHER	DIN 7603-A5X7,5-CU
	72376018	10	SEALING WASHER A5X9/7603 <-- 382/2295	DIN 7603 A5X9-VF
42	72315619	10	HEXAGONAL HEAD BOLT	DIN 933 M5X16-8.8A3L
43	72409022	2	FLANGE	

FAVORIT 611 (382/00001-99999)
6088

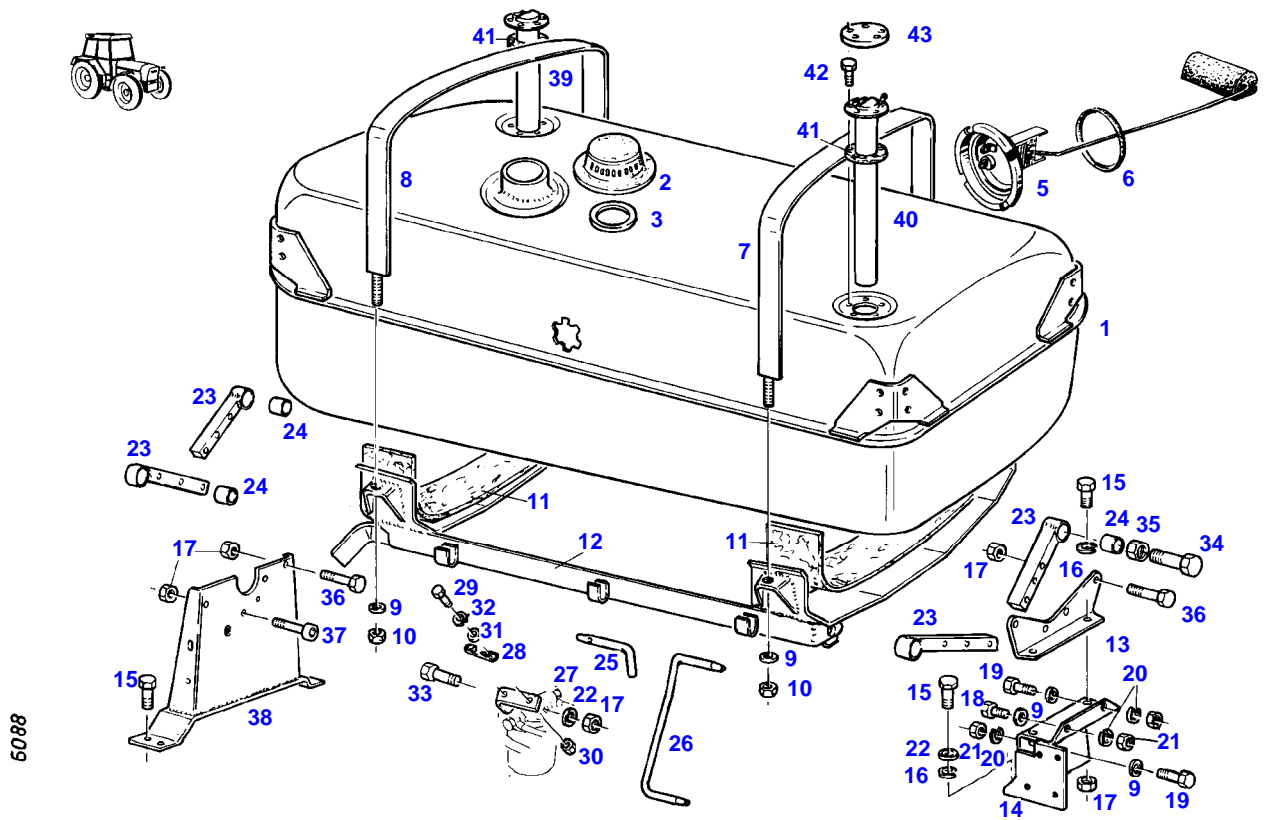

Item	Part Number	Qty	Description Comments	Technical Specification
			<-- 382/2258	
1	72364691	1	FUEL TANK	
2	72350303	1	FUEL CAP	
			><2+3	
3	72312304	1	RUBBER SEAL	
5	72613427	1	FUEL LEVEL SENSOR	
			><5+6	
	72380148	1	FUEL LEVEL SENSOR	
			><5+6	
			ADDITIONAL CONTAINER	
6	72315169	1	SEALING WASHER	
7	72362041	1	BAND CLAMP	
8	72362042	1	BAND CLAMP	
9	72311788	8	DISC	DIN 125-8,4-ST.A3L
10	72313320	4	NUT	DIN6925-M8-8-A3L
11	72404934	2	FELT TAPE	
12	72364628	1	FRAME	
13	72409376	1	BRACKET	
14	72364687	1	CONSOLE	
15	72315678	9	HEXAGONAL HEAD BOLT	DIN 933 M10X20-8.8
16	72315054	4	SPLIT WASHER	FWN 65208-10-A3L
17	72313272	12	NUT	DIN 934 M10-8A3L
18	72315659	1	HEXAGONAL HEAD BOLT	DIN 933 M8X35-8.8
19	72315663	3	HEXAGONAL HEAD BOLT	DIN 933 M8X40-8.8A3L
20	72315053	4	SPLIT WASHER	FWN 65208-8-A3L
21	72313268	4	NUT	DIN 934 M8-8A3L
22	72311789	2	DISC	DIN 125-10,5-ST.A3L
23	72404942	4	SUPPORT ARM	
24	72310644	4	RUBBER BUSHING	
25	72397322	1	BEARING PIN	
26	72404936	1	BEARING PIN	
27	72404938	1	ANGLE	
28	72399331	1	RETAINER	
29	72315619	2	HEXAGONAL HEAD BOLT	DIN 933 M5X16-8.8A3L
30	72313264	2	NUT	DIN 934 M5-8A3L
31	72311818	2	DISC	DIN9021-5,3-140HV-A3L
32	72315051	2	SPLIT WASHER	FWN 65208-5-A3L
33	72315689	1	HEXAGONAL HEAD BOLT	DIN 933 M10X35-8.8A3L
34	72374215	2	HEXAGONAL HEAD BOLT	DIN 931 M12X65-8.8
35	72313325	2	NUT	DIN 980-VM12-8-A3L
36	72315693	7	HEXAGONAL HEAD BOLT	DIN 933 M10X45-8.8A3L
37	72374898	1	SOCKET HEAD BOLT	DIN 6912-M10X45-8.8
38	72364688	1	CONSOLE	
39	72380152	1	FUEL LEVEL SENSOR	
40	72380153	1	FUEL LEVEL SENSOR	
			<-- 382/2295	
41	72376132	2	SEALING WASHER	
			40,5X65X2,4	
			<-- 382/2295	
			<> X540 000 478 12X	
			<>	
	72376017	12	SEALING WASHER	DIN 7603-A5X7,5-CU
	72376018	10	SEALING WASHER	DIN 7603 A5X9-VF
			A5X9/7603	
			<-- 382/2295	
42	72315619	10	HEXAGONAL HEAD BOLT	DIN 933 M5X16-8.8A3L
43	72409022	2	FLANGE	

FAVORIT 611 (382/00001-99999)
39733

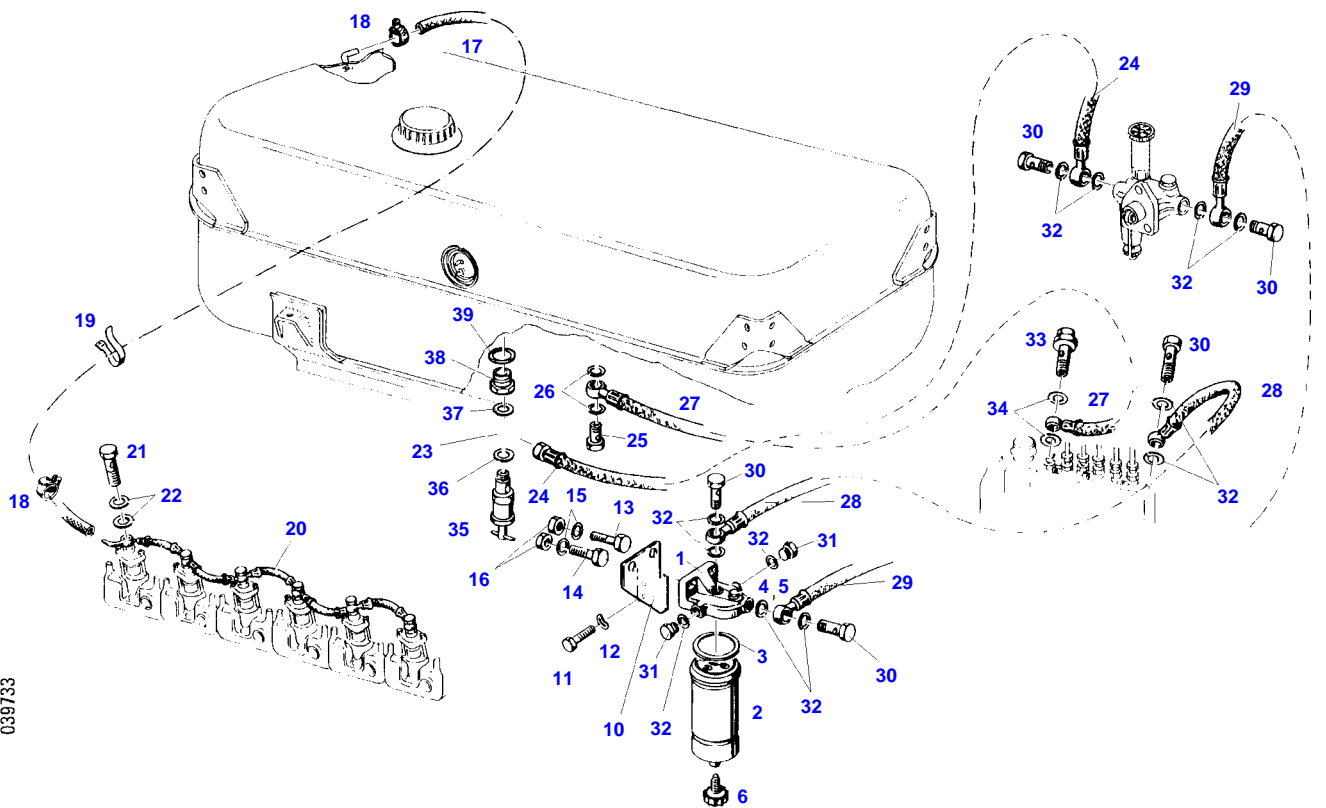

Item	Part Number	Qty	Description Comments	Technical Specification
1	72350307	1	FUEL FILTER ><1-3	
2	72416928	1	FILTER BOX ><2+3	
3	72314995	1	RUBBER RING	
4	72323290	1	BLEED SCREW	
5	72315084	1	SEALING WASHER	DIN 7603 A6X10-CU
6	72330827	1	DRAIN SCREW	
10	72409304	1	RETAINING BRACKET	
11	72315646	2	HEXAGONAL HEAD BOLT	DIN 933 M8X18-8.8A3L
12	72311824	2	DISC	DIN9021-8,4-140HV-A3L
	72315053	2	SPLIT WASHER	FWN 65208-8-A3L
13	72315685	1	HEXAGONAL HEAD BOLT	DIN 933 M10X30-8.8A3L
14	72315689	1	HEXAGONAL HEAD BOLT	DIN 933 M10X35-8.8A3L
15	72311789	2	DISC	DIN 125-10,5-ST.A3L
16	72313272	2	NUT	DIN 934 M10-8A3L
17	72435830	1	PRESSURE HOSE 1390 MM CUT TO LENGTH	L=2100
18	72438345	2	HOSE CLIP	
19	72316916	3	CABLE STRAP	FWN 66650 B175X4-SW
20	72340112	1	LEAKAGE OIL LINE --> 382/2000	
	72343884	1	LEAKAGE OIL LINE <-- 382/2001	
21	72315809	6	BANJO BOLT --> 382/2000	DIN 7643-4-5-A3L
	72342985	6	SCREW <-- 382/2001	
22	72315086	12	SEALING WASHER	DIN 7603 A8X11,5-CU
23	72377538	1	BANJO UNION	
24	72364540	1	FUEL LINE	
25	72315807	1	BANJO BOLT	DIN 7643-8-3-A3L
26	72315090	2	SEALING WASHER	DIN 7603 A12X15,5-CU
27	72364689	1	FUEL LINE	
28	72362049	1	FUEL LINE	
29	72362048	1	FUEL LINE	
30	72315808	5	BANJO BOLT	DIN 7643-10-3-A3L
31	72315799	2	PLUG	DIN 7604 AM14X1,5-A3L
32	72315094	12	SEALING WASHER	DIN 7603 A14X18-CU
33	72317103	1	BLEED AND DRAIN VALVE	
34	72315095	2	SEALING WASHER	DIN 7603 A14X20-CU
35	72380161	1	FUEL SHUT-OFF VALVE	
36	72315099	1	SEALING WASHER	DIN 7603 A18X22-CU
37	72315098	1	SEALING WASHER	DIN 7603 A16X22-CU
38	72409020	1	REDUCER	
39	72315104	1	SEALING WASHER	DIN 7603 A26X31-CU
40	72393682	1	MARKING PLATE ARABIAN-ENGLISH	

FAVORIT 611 (382/00001-99999)
6090

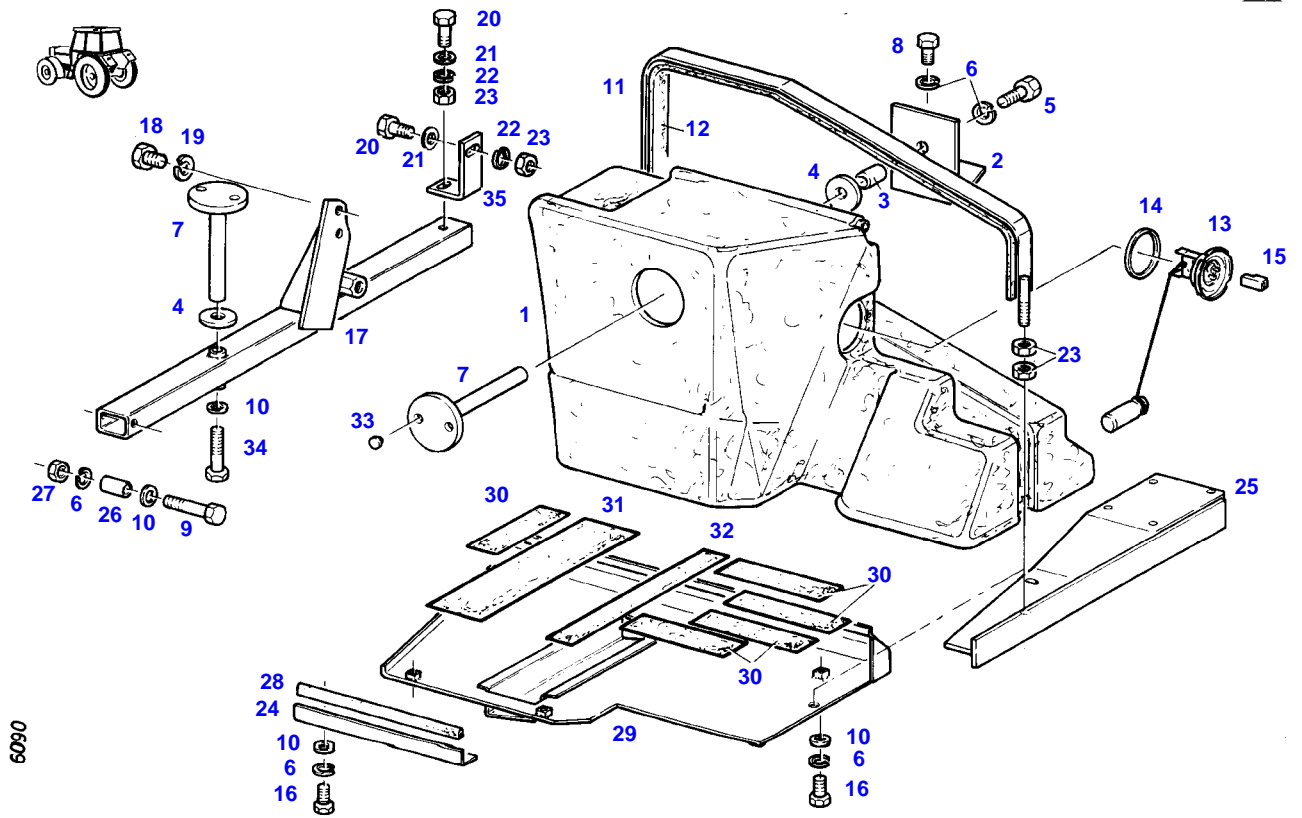

Item	Part Number	Qty	Description Comments	Technical Specification
1	72364665	1	AUXILIARY CONTAINER	
2	72409340	1	SUPPORT PLATE	
3	72394749	1	PIPE	
4	72409342	2	DISC	
5	72315530	1	HEXAGONAL HEAD BOLT	DIN 931 M8X55-8.8
6	72315053	7	SPLIT WASHER	FWN 65208-8-A3L
7	72364670	2	TIE ROD	
8	72315645	2	HEXAGONAL HEAD BOLT	DIN 933 M8 X 12-8.8A3L
9	72315673	1	HEXAGONAL HEAD BOLT	DIN 933 M8X75-8.8A3L
10	72311824	5	DISC	DIN9021-8,4-140HV-A3L
11	72364661	1	BAND CLAMP	
12	72450972	1	PROTECTIVE SECTION 1X 910 MM CUT TO LENGTH	L=920 FWN 63040 H01
13	72380151	1	FUEL LEVEL SENSOR	
14	72315169	1	SEALING WASHER	
15	72316071	2	BUSHING INSULATOR	
16	72315650	3	HEXAGONAL HEAD BOLT	DIN 933 M8 X 20-8.8A3L
17	72364667	1	BRACKET --> 382/2089 <> 385 200 907 050 (1X) X487 535 641 (1X) X428 203 239 (1X) X450 008 708 (2X) X520 805 001 (1X) <>	
	72315055	1	SPLIT WASHER	FWN 65208-12-A3L
	72315709	1	HEXAGONAL HEAD BOLT	DIN 933 M12X30-8.8A3L
	72311791	2	DISC	DIN 125-13-ST.A3L
	72409344	1	ANGLE	
	72313276	1	NUT	DIN 934 M12-8A3L
18	72315721	2	HEXAGONAL HEAD BOLT	DIN 933 M14X25-8.8A3L
19	72315056	2	SPLIT WASHER	FWN 65208-14-A3L
20	72315709	2	HEXAGONAL HEAD BOLT	DIN 933 M12X30-8.8A3L
21	72311791	3	DISC	DIN 125-13-ST.A3L
22	72315055	2	SPLIT WASHER	FWN 65208-12-A3L
23	72313276	6	NUT	DIN 934 M12-8A3L
24	72409341	1	ANGLE	
25	72364668	1	BRACKET	
26	72403628	1	PIPE	
27	72313268	1	NUT	DIN 934 M8-8A3L
28	72451141	1	PROTECTIVE STRIP 1X 350 MM CUT TO LENGTH	L=800 FWN 63040
29	72364669	1	TANK PROTECTION PAN	
30	72390672	5	STRIP	
31	72394594	1	FELT TAPE	
32	72391503	1	BAND	
33	72314743	2	LOCKING PLUG	F2
34	72315539	1	HEXAGONAL HEAD BOLT	DIN 931 M8X80-8.8 A3L
35	72409344	1	ANGLE <-- 382/2090	

FAVORIT 611 (382/00001-99999)
6091

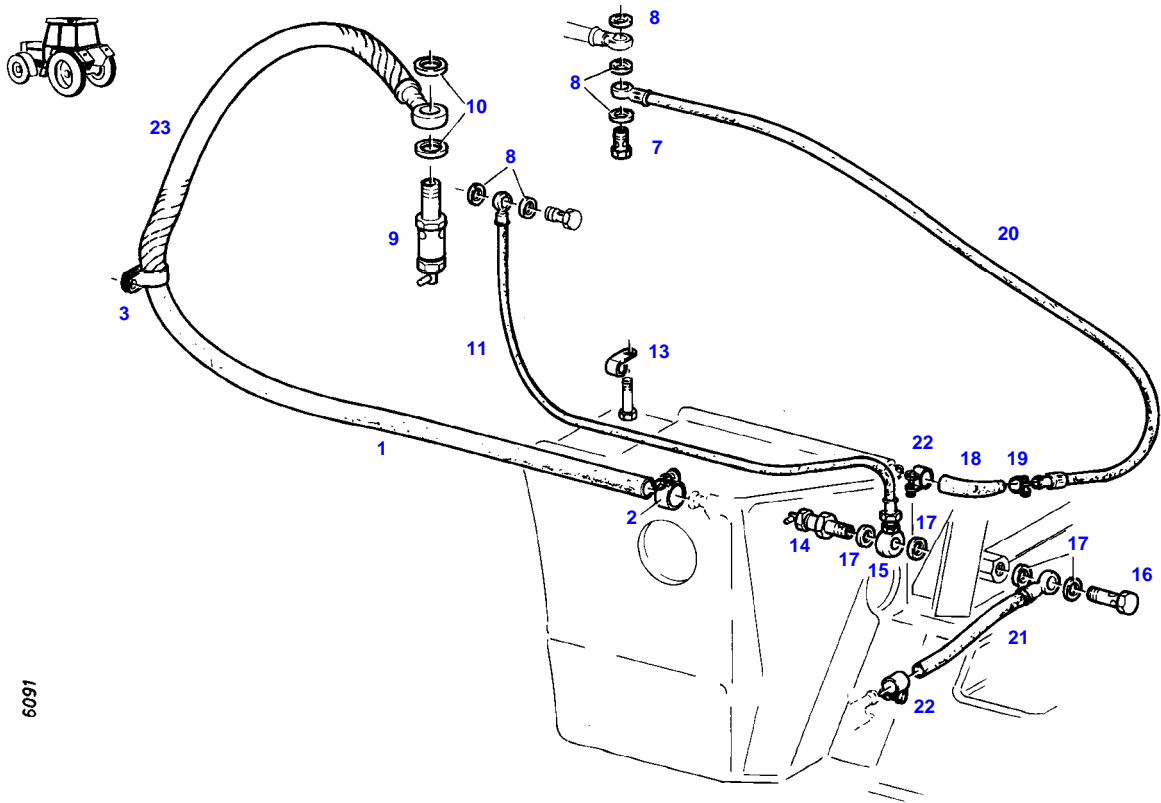

Item	Part Number	Qty	Description Comments	Technical Specification
			--> 382/2980	
1	72364671	1	FUEL LINE	
2	72311168	1	HOSE CLIP	
3	72373551	1	PIPE CLAMP	
7	72310188	1	BANJO BOLT	
8	72315090	5	SEALING WASHER	DIN 7603 A12X15,5-CU
9	72380162	1	FUEL SHUT-OFF VALVE	
10	72315104	2	SEALING WASHER	DIN 7603 A26X31-CU
11	72364674	1	FUEL LINE	
13	72311244	2	PIPE CLAMP	
14	72380163	1	FUEL SHUT-OFF VALVE	
15	72377538	1	BANJO UNION	
16	72315866	1	BANJO BOLT	
17	72315099	4	SEALING WASHER	DIN 7603 A18X22-CU
18	72409343	1	RUBBER ARCH	
19	72311166	1	HOSE CLIP	
20	72450301	1	PRESSURE HOSE 650 MM CUT TO LENGTH X591.494.000.620 300 MM <>	L=1000
	72315654	1	HEXAGONAL HEAD BOLT	DIN 933 M8X28-8.8A3L
	72438345	4	HOSE CLIP	
	72316916	2	CABLE STRAP	FWN 66650 B175X4-SW
	72313268	1	NUT	DIN 934 M8-8A3L
	72380023	1	TEE FITTING	
	72311244	1	PIPE CLAMP	
	72315053	1	SPLIT WASHER	FWN 65208-8-A3L
	72409345	1	REDUCING STUD	
	72315866	1	BANJO BOLT	
21	72364673	1	FUEL LINE	
22	72311166	2	HOSE CLIP	
23	72436908	1	HOSE PROTECTOR 1X 2000 MM	L=2000

FAVORIT 611 (382/00001-99999)
7641

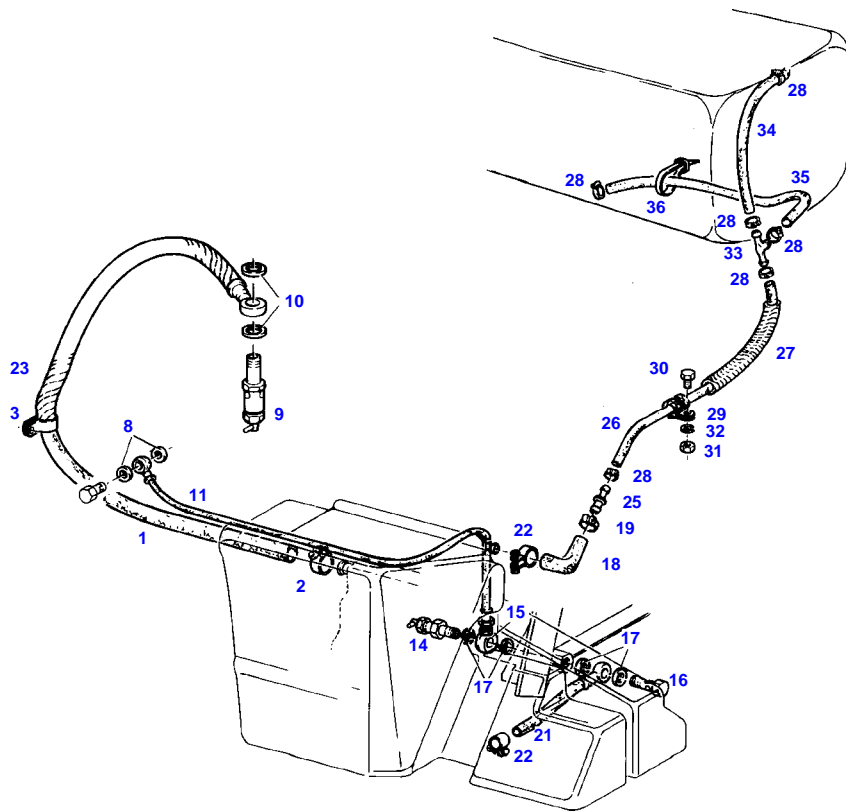

7641

Thank you so much for reading.
Please click the “Buy Now!”
button below to download the
complete manual.



After you pay.

You can download the most
perfect and complete manual in
the world immediately.

Our support email:

ebooklibonline@outlook.com